

# NASA Technical Memorandum 101494

OPTIMIZATION BY DECOMPOSITION: A STEP  
FROM HIERARCHIC TO NON-HIERARCHIC SYSTEMS

Jaroslław Sobieszczanski-Sobieski

(NASA-TM-101494) OPTIMIZATION BY  
DECOMPOSITION: A STEP FROM HIERARCHIC TO  
NON-HIERARCHIC SYSTEMS (NASA) 29 pCSCL 01C

N89-13423

Unclas  
G3/05 0174584

September 1988



National Aeronautics and  
Space Administration

Langley Research Center  
Hampton, Virginia 23665-5225

## **INTRODUCTION AND PRESENTATION PLAN**

The purpose of this presentation is to update the status report on optimization by decomposition research underway at NASA LaRC given at the predecessor meeting of this symposium in 1984. The update is focused on three developments: completion of a large scale demonstration of hierarchic decomposition applied to a transport aircraft, determination that the top-down decomposition is limited to hierarchic systems, and a proposed new algorithm for optimization by decomposition applicable to non-hierarchic systems.

- **HIERARCHIC COMPOSITION APPLIED TO TRANSPORT AIRCRAFT.**
- **LIMITATIONS OF THE APPROACH.**
- **NON-HIERARCHIC SYSTEMS: ATTRIBUTES A SOLUTION SHOULD HAVE.**
- **A NEW ALGORITHM PROPOSED AS A SOLUTION.**
- **CONCLUSIONS.**

Figure 1

## OPTIMIZATION BY LINEAR DECOMPOSITION: ITS USEFULNESS AND LIMITATIONS

Implementation and application experience with optimization by linear decomposition has been reported several times since introduction of the concept in ref.1. The concept applies to systems amenable to a hierarchic representation as shown in Fig.2a. In such applications, the general flow of information takes the analysis results from a parent to the daughters, and the optimization results and their sensitivity to the parameters received as parent output are transmitted back to the parent as seen in Fig.2b. This approach was successful in formulating structural optimization by substructuring in ref.2, and in solving a very large multidisciplinary optimization problem related to a transport aircraft design reported in ref.3 and summarized in the next three figures.

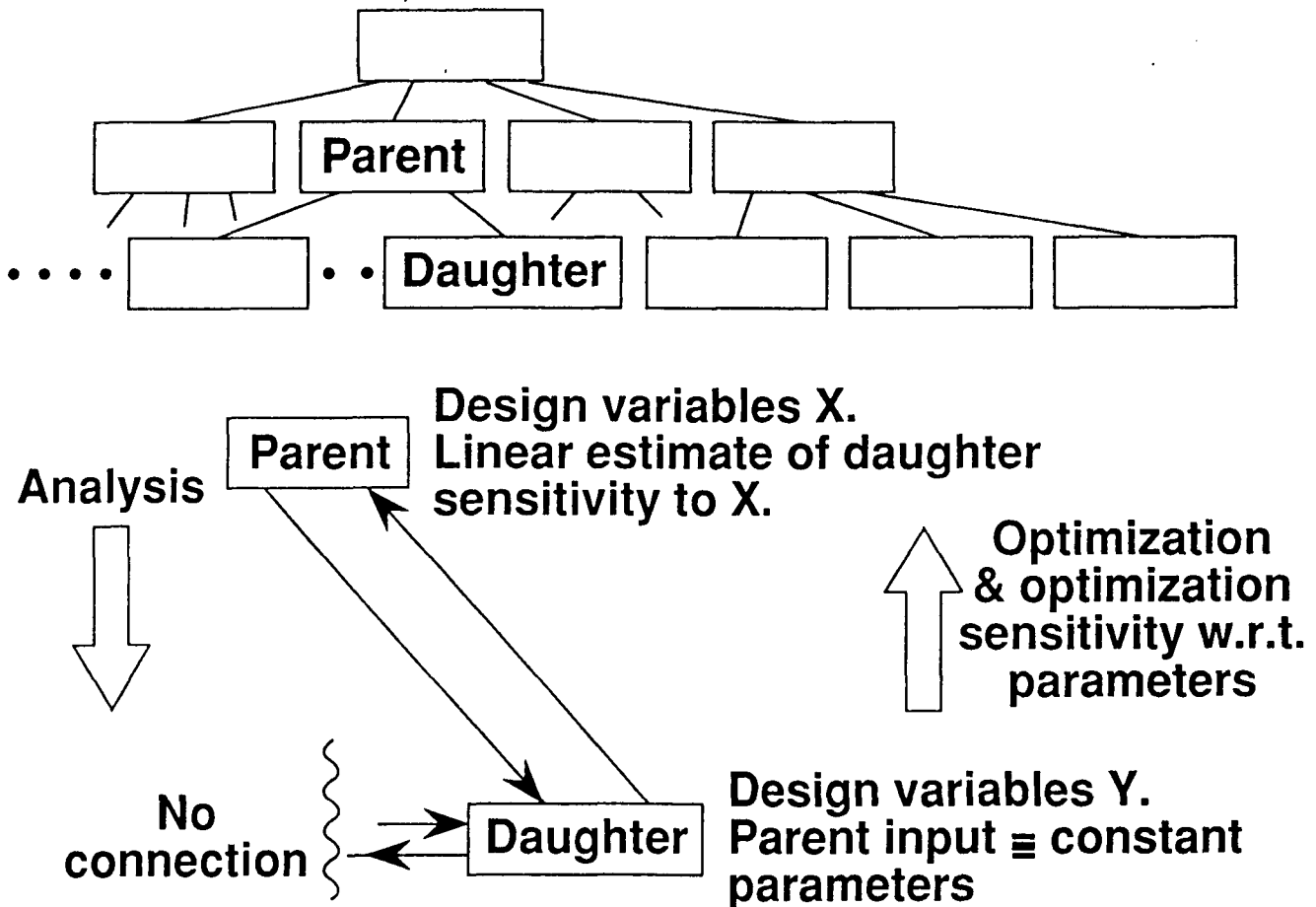
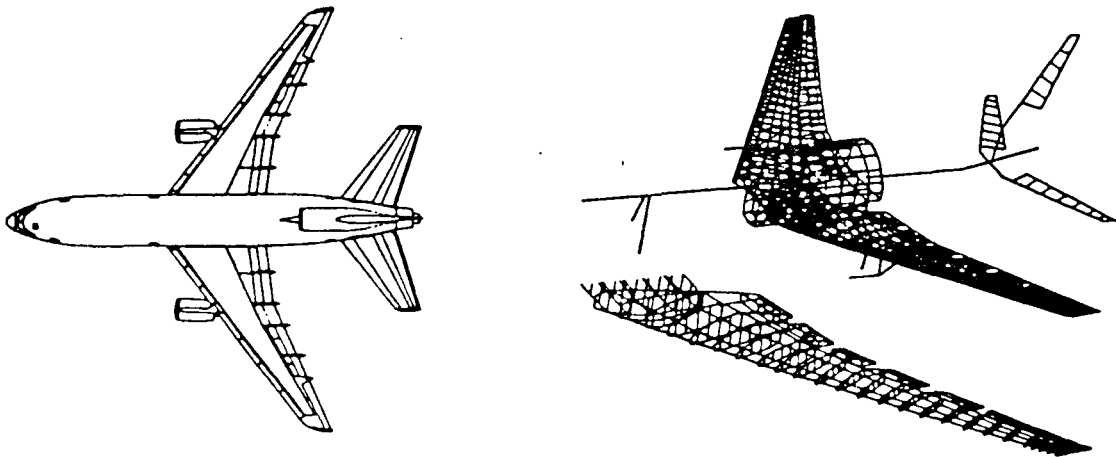

Figure 2

## A TRANSPORT AIRCRAFT CONFIGURATION

A version of the L1011 was used as a test case in ref.3. The configuration and its finite element model representation are shown in Fig.3. The objective function was the block fuel consumption for a particular mission profile, the constraints were drawn from structures, and aircraft performance, and the design variables were cross-sectional dimensions of stiffened wing covers, stiffness-equivalent wing cover membrane element thicknesses, and the airfoil depth-to-chord ratio at the three decomposition levels shown in the next figure. There were more than 1000 design variables, constraints, and elastic degrees of freedom in the finite element analysis, so the problem was quite large as far as nonlinear programming optimization is concerned.

- **Typical transport (L1011) and its finite element model**



- **Objective: minimize fuel used for a given mission**
- **Large, multidisciplinary problem**
  - **1950 constraints for structures, aerodynamics, and performance**
  - **1303 design variables from detailed stringer dimensions to airfoil depth**

Figure 3

## TRANSPORT AIRCRAFT LINEAR DECOMPOSITION

The objective function and system performance are represented in box 1 on the top of the hierarchy shown in Fig.4 that displays also the type of information transmitted between the levels. The mid-level consists of the wing box represented by an assembly of rods and membrane elements, the latter having orthotropic stiffnesses to account for their stringer-sheet construction. The stringer-sheet detailed dimensions were recognized as design variables at the lowest level where each wing cover panel was considered as a separate optimization problem.

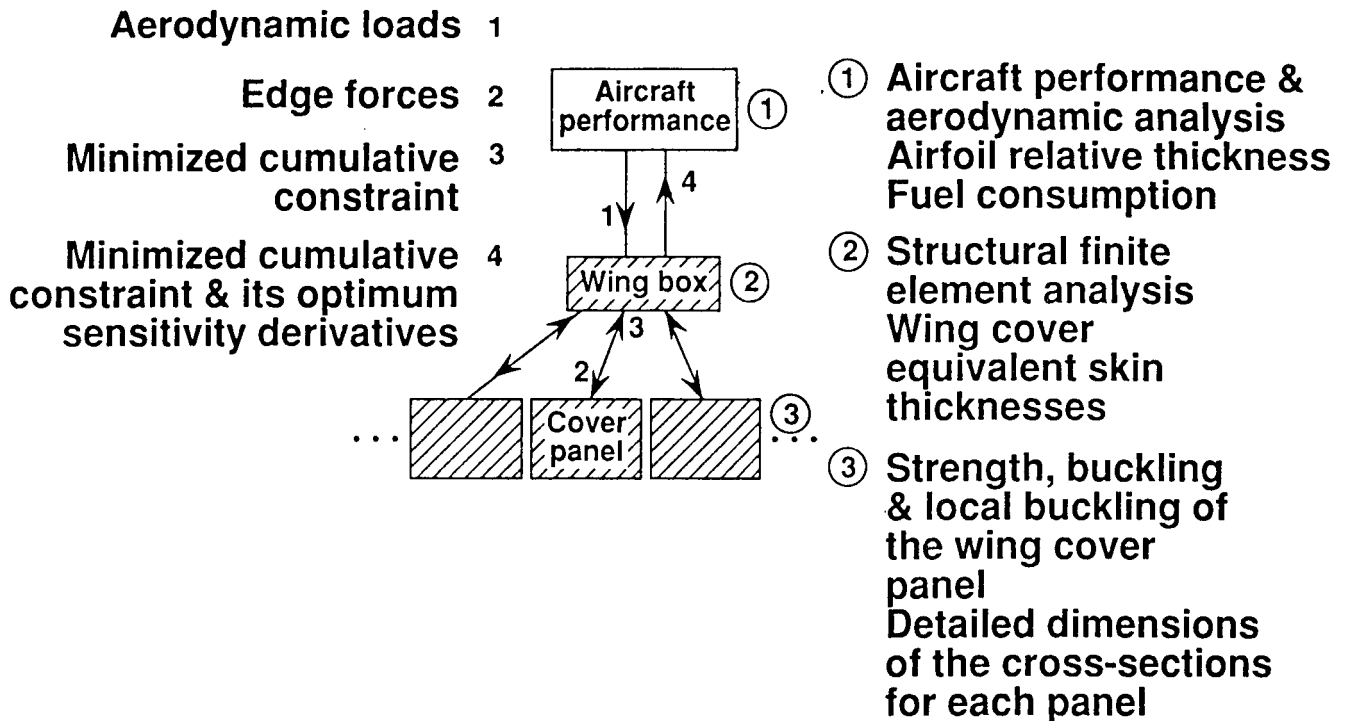
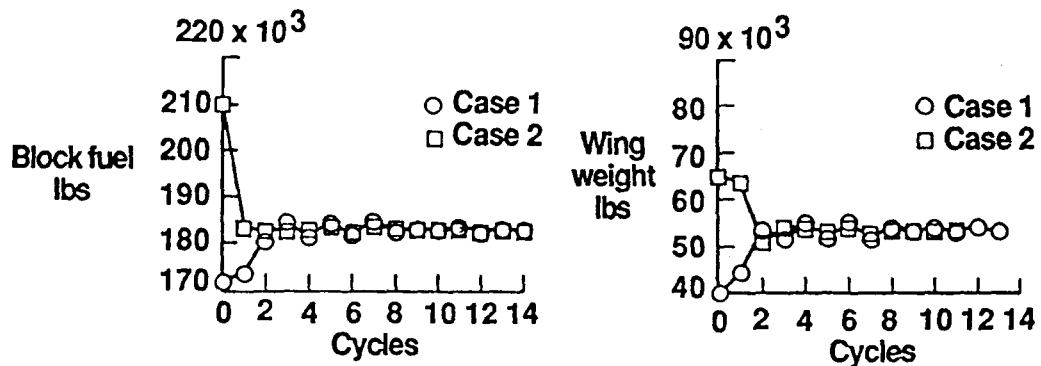

Figure 4

## SAMPLE OF TRANSPORT AIRCRAFT RESULTS

Test optimizations were performed from design points deliberately initialized away from the existing L1011 design in both feasible and infeasible directions. Two typical results shown in Fig.5 indicate convergence at a quite fast rate to the same results very close to the existing design. Since the subject design was well established and previously optimized by other means, the convergence to the existing design constituted a positive test of the method which demonstrated that it is possible to link mathematically a design detail at the bottom of the hierarchy to the system performance at the top in a large problem.

Several other examples of multilevel optimization are reviewed in ref.4 of this symposium.



- **Fast convergence from initially infeasible and feasible designs**
- **Compared well with actual L1011 data**
- **Decomposition made it possible:**
  - **To handle more than 1000 design variables in an NLP-based optimization**
  - **To link mathematically the design detail to system performance**

Figure 5

## MANY SYSTEMS ARE NOT HIERARCHIC IN NATURE.

An example of a system not amenable to a hierarchic decomposition discussed above is a network system whose generic example is shown in Fig.6a. Each box labeled CA  $k$  for Contributing Analysis represents an analysis module contributing to the entire system analysis. A CA may be associated with a particular aspect of the system behavior or may represent a physical subsystem. In either case, its is treated as a black box converting input into output. The input consists of outputs from the other CA's, and of the design variables and constants prescribed externally to the system.

A specific example for a system like this is given in Fig.6b showing a schematic of an actively controlled, flexible wing described in ref.5. Although one would tend to place the PERFORMANCE at the system level, the presence of the lateral link between AERODYNAMICS and STRUCTURES, and the two-way flow of information along other links precludes decomposition of this system into a top-down, hierarchic structure because one cannot limit the inputs received by a daughter to those from one parent only. Conversely, it is no longer possible to have a unique channel of influence between a daughter and the corresponding parent because part of the daughter influence may be channeled through another daughter.

Hence, another way of decomposition must be found for network systems and this inspires a non-hierarchic approach. The remainder of this paper presents a new algorithm derived from that approach. The algorithm addresses large design problems in which each CA may, typically, be tended by a group of engineers within a framework of design organization. In that setting, it is recognized that organizational and human cooperation issues are as important as the mathematical computational aspects of the problem.

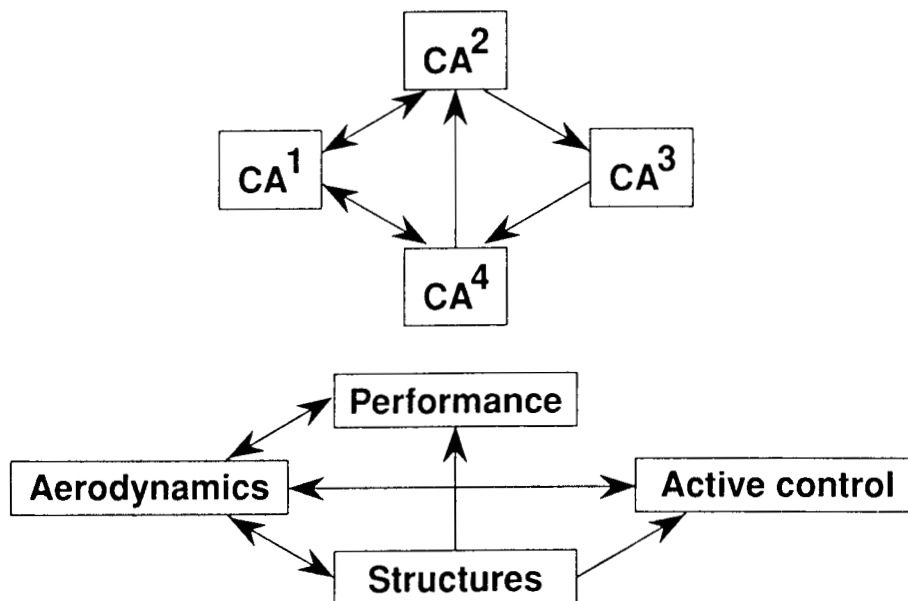

Figure 6

## SYSTEM OPTIMIZATION PROBLEM DEFINITION

An optimization problem for the system presented in Fig.6 is defined in Fig.7. It calls for finding a set of design variables  $X$  that minimizes an objective function  $F(Y,X,P)$  subject to constraints  $g(Y,X,P)$ . The  $F$  and the  $g$  functions are assumed to be computed within the appropriate CA's from the behavior variables  $Y$  which are the unknowns in each CA, e.g, displacements in a stiffness-based finite element analysis. The constants are denoted by  $P$ .

If the system optimization were to be solved as a single problem, the procedure schematic might look like the one at the bottom of Fig.7.

$$\min F(Y, X, P), \text{ where } Y = f(X, P) \quad (1)$$

$X$

$$\text{subject to } g_j(Y, X, P) \leq 0; j = 1, NCON \quad (2)$$

$$g_j = \frac{\text{Demand}}{\text{Capacity}} - 1$$

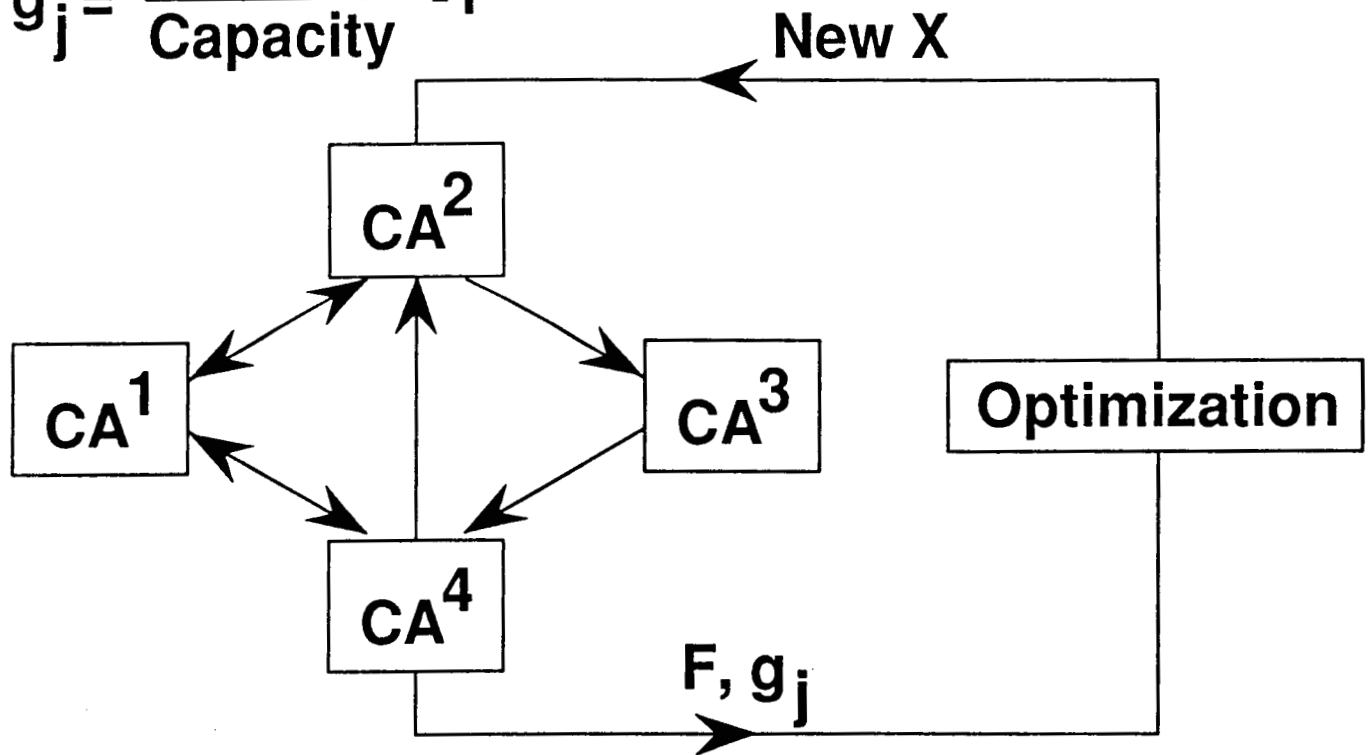

Figure 7



## **NEED FOR A NEW PROCEDURE FOR NETWORK SYSTEM OPTIMIZATION.**

For a large application, the single optimization problem approach is obviously impractical. It needs to be replaced by a procedure specifically tailored to meet the requirements of an engineering design organization it is intended for. Experience with computational support needed in industrial design processes suggests that at least the following major requirements be met.

- **PROCEDURE SHOULD DEFINE A SYSTEM FEASIBLE IN ALL ITS PARTS AND ASPECTS, IMPROVED IN ITS PERFORMANCE OVER THE INITIAL STATE.**
- **SYSTEM ANALYSIS, SENSITIVITY ANALYSIS, AND OPTIMIZATION SHOULD BMODULAR AND DIVIDED TO THE GREATEST EXTENT POSSIBLE INTO CLEARLY SEPARATED TASKS ASSIGNED TO SPECIALTY GROUPS THAT MAKE UP A DESIGN ORGANIZATION WHICH MAY BE GEOGRAPHICALLY DISPERSED.**
- **SYSTEM ANALYSIS REPETITIONS SHOULD BE AS FEW AS POSSIBLE.**
- **EACH GROUP SHOULD BE QUANTITATIVELY INFORMED ABOUT THE INFLUENCE THEIR DESIGN DECISIONS HAVE ON THE OTHER GROUPS' TASKS AND ON THE SYSTEM OBJECTIVES WHILE RETAINING RESPONSIBILITY FOR ITS RESULTS.**
- **SPECIALIZED METHODS IN ANALYSIS, SENSITIVITY ANALYSIS, AND OPTIMIZATION, AND USE OF OTHER SOURCES OF INFORMATION IN LIEU OF CALCULATIONS, SHOULD BE ADMISSIBLE IN EACH GROUP'S TASK.**
- **GROUPS SHOULD BE ABLE TO DO THEIR WORK CONCURRENTLY TO THE GREATEST EXTENT POSSIBLE.**
- **HUMAN JUDGMENT AND INTERVENTION SHOULD BE ACCOMMODATED AND SUPPORTED.**
- **PROCEDURE SHOULD BE OPEN-ENDED REGARDING THE SIZE OF THE ENTIRE TASK AND ADJUSTABLE TO THE DEPTH OF DETAIL CONSISTENT WITH THE DESIGN STAGE.**

Figure 8

## **NEW ALGORITHM DERIVES FROM SUBSPACE OPTIMIZATION METHOD.**

It should be possible to meet the above requirements by following an approach suggested by the well-known method of subspace optimizations (SSO). The method changes a subset of the design variable vector at a time, while holding the remainder of the vector constant. The univariate search is its ultimate implementation. However, the conventional subspace optimization technique requires repetition of the full system analysis for each subspace that may be cost-prohibitive in large systems. Also, it does not provide for concurrent execution of the separate subspace optimizations - a feature regarded as essential for applications in engineering design process. Therefore, the technique must be modified to reduce computational cost and to allow for concurrent optimizations.

The algorithm implementing the above modifications will be presented as a "walk through", with a rationale for each step given as the steps unfold, building toward a complete flowchart.

- **CONVENTIONAL SUBSPACE OPTIMIZATION METHOD MANIPULATES ONE SUBSET OF DESIGN VARIABLES AT A TIME, HOLDING THE OTHER SUBSETS CONSTANT.**
- **UNIVARIATE SEARCH IS THE ULTIMATE OF THE ABOVE.**
- **IN THE PROPOSED ALGORITHM, SUBSPACE OPTIMIZATION METHOD IS MODIFIED TO ELIMINATE THE NEED FOR FULL ANALYSIS FOR EACH SUBSPACE, TO ALLOW CONCURRENT OPTIMIZATIONS IN SUBSPACES, AND TO MEET OTHER SPECIFIED REQUIREMENTS.**

Figure 9

## SYSTEM ANALYSIS

The system optimization procedure begins with a system analysis (SA) presented in Fig.10. The superscripts identify the CA's and the corresponding partitions of Y, and X. In the most general case, the system may be fully coupled, so that each CA sends its output Y to input in every other CA. However, in most practical cases, a particular CA transmits some of its Y elements to some of the other CA's. If there are two-way couplings and if the CA's involved are non-linear, the SA requires iterations for its solution. A typical example is an iteration between nonlinear aerodynamic and structural analyses to converge the aerodynamic loads and structural displacements of an elastic wing.

In most applications, the CA's are simply computer programs, but they may also represent experiments, graphs, look up tables, or even guesstimates, in other words, a CA may be any source of information producing output in response to an input presented to it.

$$\begin{array}{l} CA^1 ((X^1, Y^2, Y^3, \dots Y^k), Y^1) \\ CA^2 ((X^2, Y^1, Y^3, \dots Y^k), Y^2) \\ CA^3 ((X^3, Y^1, Y^2, \dots Y^k), Y^3) \\ \vdots \\ CA^k ((X^k, Y^1, Y^2, Y^3, \dots), Y^k) \\ \vdots \end{array}$$

Figure 10

## SYSTEM SENSITIVITY ANALYSIS

Following the SA, we perform a system sensitivity analysis (SSA) to compute the system sensitivity derivatives (SSD). These derivatives are defined in Fig.11, Eq.1. Each derivative is a measure of the influence of a particular design variable X on a particular behavior variable Y. It is crucially important to have these influences computed to fully account for the couplings among the CA's. This may be accomplished per ref.6, by computing for each CA the partial sensitivity derivatives of its output w.r.t. its input, the input including the Y's received from the other CA's and those X variables which are directly input into that CA. Any sensitivity analysis techniques appropriate for the nature of a particular CA may be used in this operation, including finite difference procedures, although analytical and semi-analytical methods are preferred for their efficiency and accuracy. It is important for the organization of this phase of the sensitivity analysis that the partial sensitivity derivatives may be computed concurrently for all the CA's.

The partial derivatives enter the matrix of coefficients and the right hand side vectors of a set of simultaneous, linear, algebraic equations termed Global Sensitivity Equations (GSE) in ref.6 and shown in Fig.11, Eq.2. Solution of these equations yields a vector of the system sensitivity derivatives for each design variable X represented on the right hand side. Having the derivatives of Y with respect to X available, enables one to also obtain the derivatives of the F and g functions with respect to X by simple postprocessing. These derivatives measure the first order influence of each design variable on the objective function and all constraints in the system, even though the influences may be indirect. As we will see later, this capability plays a key role in decomposing the system for optimization purposes while retaining a degree of coupling.

$$\frac{dY_i^p}{dX_j^k} ; i = 1, NY^p; p = 1, NSS; k = 1, NX^k \quad (1)$$

$$\begin{bmatrix} \dots & \dots & \dots \\ \dots & \left[ \begin{array}{c} \frac{\partial Y^p}{\partial X^k} \\ \frac{\partial Y^k}{\partial X^p} \end{array} \right] & \dots \\ \dots & \dots & \dots \end{bmatrix} \begin{Bmatrix} \frac{dY^p}{dX_i^2} \\ \frac{dY^k}{dX_i^2} \end{Bmatrix} = \begin{Bmatrix} \frac{\partial Y^p}{\partial X_i^2} \\ \frac{\partial Y^k}{\partial X_i^2} \end{Bmatrix} \dots \quad (2)$$

Figure 11

## **ORGANIZATION OF SEPARATE SUBSPACE OPTIMIZATIONS (SSO)**

For optimization purposes it is necessary to partition the vector  $X$  into subsets to be used in the separate optimizations replacing the large, original problem. The intent is to have each separate optimization involve only one CA. The allocation of the  $X$  partitions (subsets) to the corresponding separate optimization problems must be unique, and may be accomplished by heuristics augmented with the sensitivity information carried by the system sensitivity derivatives. The derivatives may be used to rank the variables  $X$  in order of the degree of their influence on the constraints and contributions to the objective function computed in each CA. This information, used judiciously, should guide the allocation decisions. For instance, under that approach we might find an  $X$  variable representing the cross-sectional area of a wing spar cap as the most influential on the wing strength constraints, hence that  $X$  would be allocated to the structural optimization. On the other hand, the  $X$  governing the wing span might be found to exert a strong influence on both the wing strength and aerodynamic constraints and so, in keeping with tradition, it might be judgmentally assigned to the aerodynamic optimization.

- **ONE CA**
- **SUBSET OF  $X$**
- **SINGLE CUMULATIVE CONSTRAINT REPRESENTING ALL CONSTRAINTS DERIVED FROM CA.**
- **CARRIED OUT BY A GROUP OF SPECIALISTS, E.G., WING PLANFORM OPTIMIZATION - AERODYNAMICS GROUP.**

Figure 12

## CUMULATIVE CONSTRAINT

The cumulative constraint represents by a single number all the  $g$ 's computed from the CA associated with the SSO. The cumulative constraint is formulated as a Kreisselmeier-Steinhauser function (KS function), Eq.1, per ref.7. The derivatives of the KS function with respect to a  $g$  are obtained analytically and combined in a chain differentiation with the derivatives of the  $g$  with respect to  $X$  to yield the derivatives of the cumulative constraint with respect to  $X$ , Eq.2.

Knowing the system solution, its sensitivity to design variables, and having organized the design variables and CA's in separate optimization problems, we may now begin the optimizations.

- **Kreisselmeier-Steinhauser function:**

$$KS = \frac{1}{\rho} \ln \left( \sum_j e^{\rho g_j} \right) \quad (1)$$

$$\frac{\partial KS}{\partial X_i^k} = \left( \sum_j e^{\rho g_j} \right)^{-1} \left( \sum_j \left( e^{\rho g_j} \frac{\partial g_j}{\partial X_i^k} \right) \right) \quad (2)$$

**$\rho$  = user controlled factor**

Figure 13

## SUBSPACE OPTIMIZATION (SSO)

The subspace optimizations are temporarily decoupled and executed concurrently - their coupling will be restored in the coordination problem. Here, we focus on one particular, k-th, SSO.

In the SSO, we want to reduce violation of the cumulative constraint of the k-th SSO at the least penalty of the system objective function increase, or, if the cumulative constraint is already satisfied, we want to reduce the system objective function as much as possible without violating that constraint. Remembering that we operate on a part of a system, we want to do the above while contributing to the reductions of the violated cumulative constraints in the other SSO's and without causing violation of the satisfied cumulative constraints in the other SSO's.

Recognizing that the cumulative constraint of the k-th SSO is going to get a similar consideration in the other, concurrently executed SSO's, we need to aim at reducing the violated cumulative constraint by only a fraction, counting on the other SSO's to reduce the remainder of the violation. By the same token, we may even allow the cumulative constraint to remain violated, provided that violation is offset by influence of the other SSO's.

Formally, all the above is expressed by a formulation shown in Fig.14. When the SSO's are concluded, the results are new X's, new values of the C's, and a new value of F.

$$\min F(X^k) \text{ subject to} \quad (1)$$

$$C^p \leq C^{p0} s^p (1 - r_k^p) + (1 - s^p) t_k^p; p = 1, NSS \quad (2)$$

$$X_L^k \leq X^k \leq X_U^k \quad (3)$$

- If  $CA^k$  contributes to F indirectly, then

$$F = F^0 + \sum_i \left( \frac{dF_i}{dX_i^k} \right) \Delta X_i^k \quad (4)$$

- $C^k$  from  $CA^k$  using  $Y = Y^0 + \sum_i \left( \frac{dY}{dX_i^k} \right) \Delta X_i^k$  for coupling inputs

- $C^p, p \neq k$ , from  $C^p = C^{p0} + \sum_i \left( \frac{dC^p}{dX_i^k} \right) \Delta X_i^k$  (6)

- $r_k^p, t_k^p$  are constants; variables in coordination problem

- $s^p$  is a "switch" coefficient, 0 or 1

Figure 14

## COMMENTS ON SUBSPACE OPTIMIZATION FORMULATION - COEFFICIENTS $r$

Owing to the system sensitivity derivatives, we are in a position to account for the influence we exert on the objective function of the system while performing an SSO, even if that SSO has no direct influence on that function. By the same means, we are able to consider the effect of the decisions taken in one SSO on the constraints in the other SSO's. This cross-influence is represented by linear extrapolations and is the key feature of the proposed approach. It enables all participants in design of a complex system to work in concert toward improving the design of the entire system while remaining on the familiar grounds of their own specialty domains.

In a system, the  $p$ -th violated cumulative constraint may be satisfied not only by the  $X$ -setting decisions taken in the  $p$ -th SSO but also by such decisions taken in the other SSO's owing to the couplings among the CA's. For instance, overstress in a wing spar may be reduced partially by spar cap resizing (structural SSO) and partially by decreasing the wing aspect ratio (aerodynamic configuration SSO). To account for this, we introduce coefficients  $r$  to represent the "responsibility" assigned to the  $k$ -th SSO for reducing the violation of the cumulative constraint of the  $p$ -th SSO. For this purposes, the violated constraint value normalized to unity is divided into fractions  $r_k^p$ . The superscript identifies the constraint and the subscript points to the SSO responsible for its partial reduction. Of course, all the  $r_k^p$  fractions must add up to unity when summed over  $k$  for a given  $p$  - that requirement is built into the coordination problem (to be defined later) in which these coefficients appear as variables. For each cumulative constraint there are  $NSS$  coefficients  $r_k^p$ , so for  $NSS$  cumulative constraints we have a total of  $NSS^2$  such coefficients. It is logical to use the sensitivity information to initialize the  $r$  coefficients making them proportional to the degree of influence exerted by the  $k$ -th SSO on the  $p$ -th cumulative constraint. That initialization is discussed in Appendix.

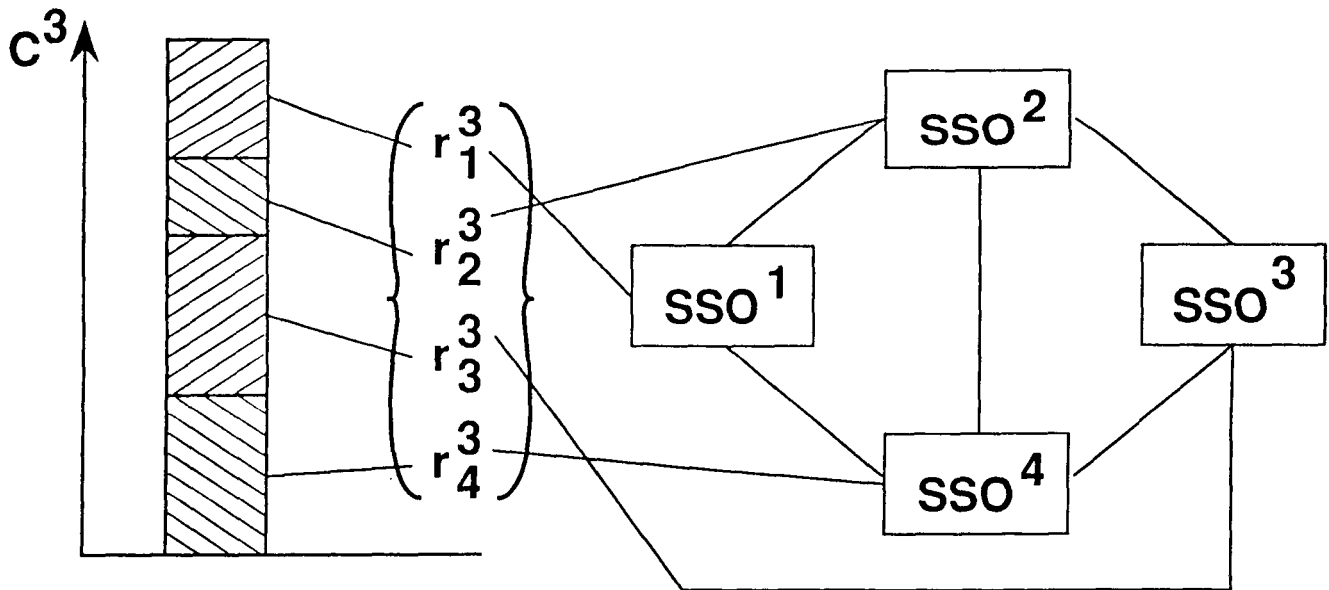

Figure 15



## COMMENTS ON SUBSPACE OPTIMIZATION FORMULATION - COEFFICIENTS $t$ .

Extending this reasoning to the case of the  $p$ -th cumulative constraint being critical for the given  $X$ , we should account for the possibility of further reducing the objective function by letting that constraint become somewhat violated in the  $p$ -th SSO, provided that the violation will be offset by oversatisfaction of that constraint in the  $k$ -th SSO. For example, should we find the wing spar stress constraint at zero (critical) in the structural SSO, we may let the stress rise above the allowable value thus reducing the spar cross-sectional area and weight, if we instruct the aerodynamic SSO to offset that violation by oversatisfying the same constraint by reducing the wing aspect ratio at the price of the induced drag increase. If the wing spar weight reduction more than offsets the induced drag increase with respect to a measure of the aircraft performance, then this is a positive trade-off the procedure ought to be able to recognize. To account for that type of trade-offs, we introduce the coefficients  $t_k^p$  whose number equals  $NSS^2$ . For the  $p$ -th cumulative constraint, the sum of these coefficients over  $k$  must be zero, to keep the constraint in the critical, but not violated, status. This condition is enforced in the coordination problem where the coefficients  $t$  appear as variables.

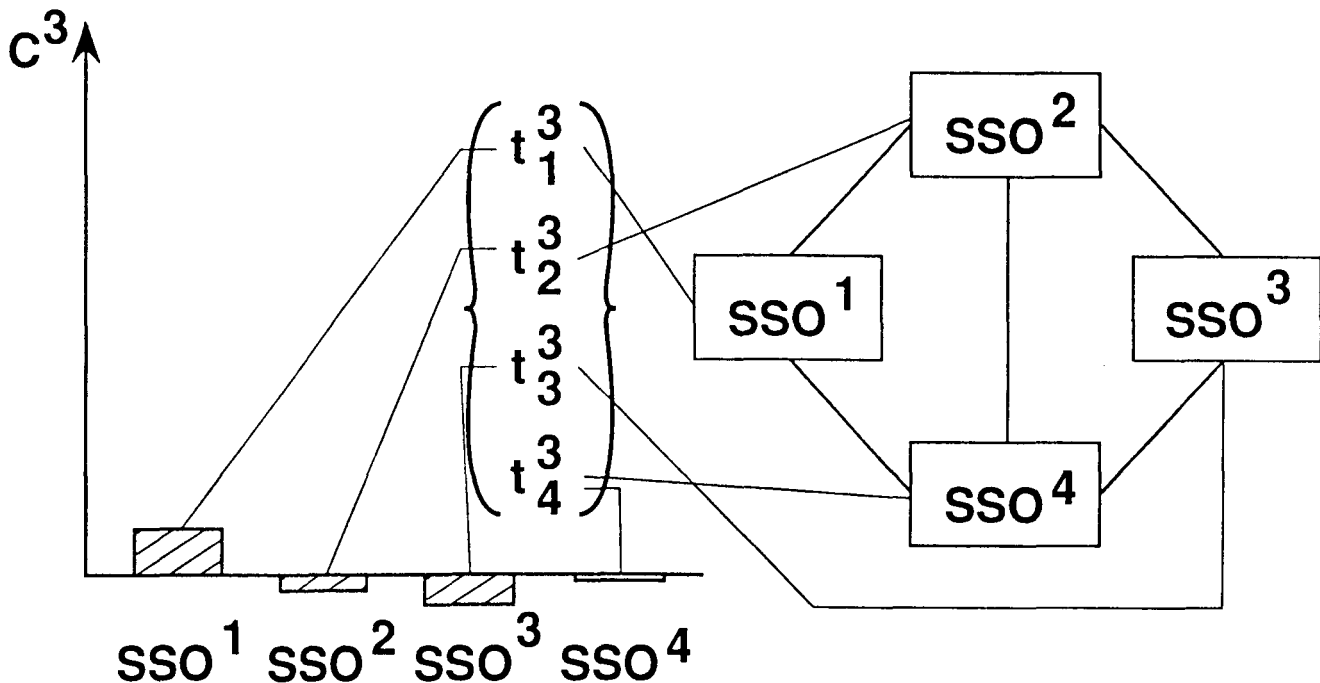

Figure 16

## COMMENTS ON SUBSPACE OPTIMIZATION FORMULATION - COEFFICIENTS $s$ .

Coefficient  $s^p$  is a switch. It is set to 1 if the corresponding  $C^p$  is violated at the outset of the system optimization procedure and stays at 1 until the  $C^p$  is driven to a critical status (zero value). Then, the coefficient  $s^p$  is reset to 0 and stays at 0 until the system optimization procedure terminates. Thus, the  $s$  coefficient enables the term containing  $r^p_k$  and disables the term containing  $t^p_k$  while the  $C^p$  violation is in the process of being reduced and vice versa after that violation has been eliminated. There is one coefficient  $s^p$  per  $C^p$  for the total of NSS coefficients  $s$ .

In summary, Eq.2 in Fig.14 works as follows. When the  $p$ -th cumulative constraint is found violated, its value  $C^{p0}$  is a positive number to be driven toward zero. This is done by dividing that number into fractions proportional to the  $r$  coefficients and by reducing each fraction toward zero independently in each separate SSO. The coefficients  $t$  set to zero and turned off by the  $s$ -switch do not interfere with that process. When the  $p$ -th cumulative constraint is reduced to zero (attains critical status), it is allowed to be violated in some SSO's and oversatisfied in other SSO's, provided that the violations and oversatisfactions are beneficial to the objective function and that they balance to zero so that the  $C^p$  critical status is preserved. This phase is controlled by the  $t$  coefficients while the  $r$  coefficients are turned off by the  $s$ -switch.

- $s^p = 1$ , if
  - $C^p > 0$  . at the outset of the  
System Optimization Procedure
  - . and .
  - $C^p$  was never reduced to  $\leq 0$  since then
  - . and .
  - $C^p > 0$  in the last SA
- Otherwise,  $s^p = 0$

Figure 17

## COMMENTS ON SUBSPACE OPTIMIZATIONS - CA AND EXTRAPOLATIONS.

In the  $k$ -th SSO, the cumulative constraint  $C^k$  is evaluated from the  $g$  values obtained from the  $CA^k$  associated with that SSO while explicit form extrapolations are used to evaluate the other  $C^p$ 's where  $p$  is not equal to  $k$ . That affords flexibility in choosing the ways each SSO is to be carried out - no uniformity is required at all. Optimization methods specialized for a particular discipline or a physical subsystem may be used, e.g., the optimality criteria for structural optimization. By the same token, a variety of techniques are admissible, such as the use of approximate, gradient-based analyses in the optimization loop, reciprocal variable replacements, etc. Instead of the direct extrapolation of  $C$ , one may also improve accuracy by first extrapolating the  $g$ 's using their derivatives w.r.t.  $X$  and, then, substitute the new  $g$ 's into the KS function to obtain a new  $C$ .

Judgmental intervention by the engineers into the optimization process is entirely acceptable too.

Regardless of the procedure, the SSO involves a CA representing the high accuracy knowledge and a set of extrapolations representing the approximate, first-order accuracy knowledge about the cross-influences on the other SSO's and on the system objective. Using an aerodynamic wing planform optimization as an example of an SSO, a group of aerodynamicists would proceed with their customary task while agreeing to include as an augmentation of that task a package of simple extrapolation formulas to inform them about the effects of their decisions on strength, control, performance, etc.

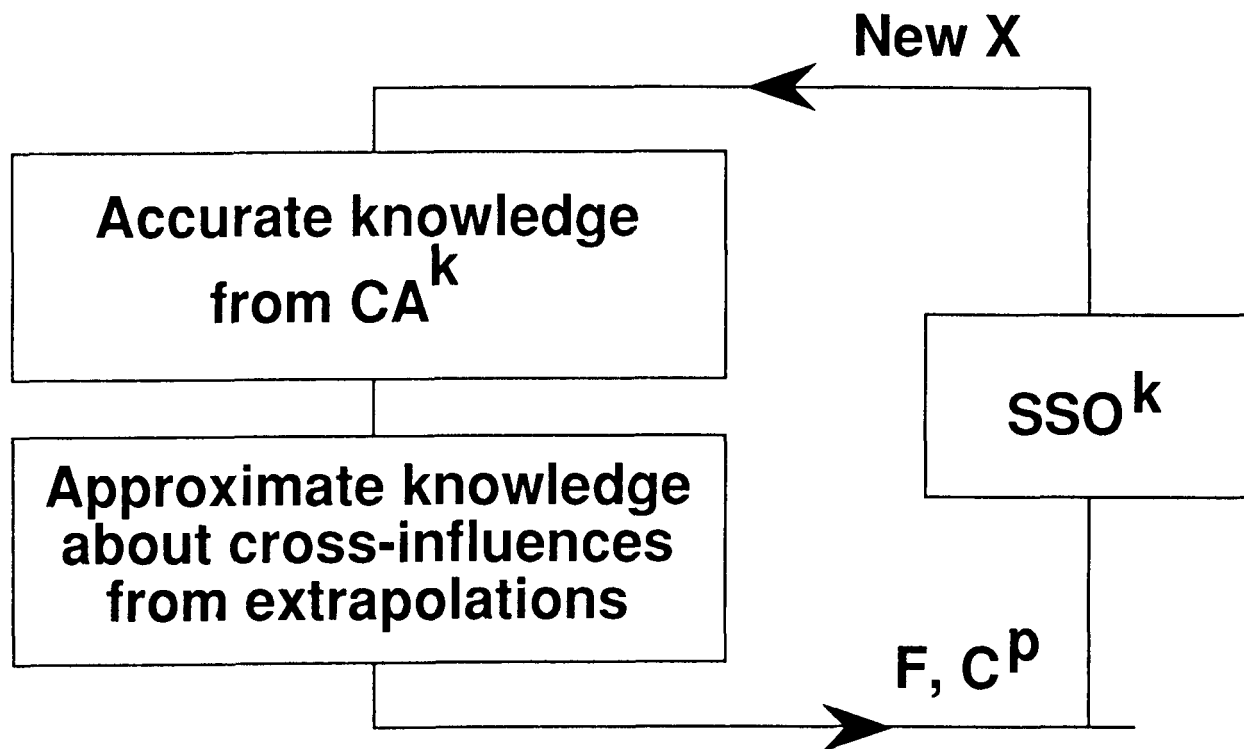

Figure 18

## OPTIMUM SENSITIVITY ANALYSES (OSA)

The SSO's were executed with the constant coefficients  $r$  and  $t$  with unique subsets of  $X$  but with a common system objective function  $F$ . Consequently, the constrained minimum of  $F$  so obtained is a function of the constants  $r$  and  $t$ , and its derivatives with respect to  $r$  and  $t$  exist in the sense of ref.8 and 9. Per ref.9, the derivatives are computed from the expressions shown below using the gradient information for the  $F$  and  $C$  functions. The gradient information with respect to the  $X$ 's is available at the conclusion of the SSO's, provided that a gradient-guided optimizer was used in these optimizations. The gradients with respect to the  $r$ 's and  $t$ 's are trivial to obtain owing to the simplicity of Eq.2 in Fig.14.

Once the derivatives of  $F$  are available, the  $F$  function may be approximated in terms of  $r$ 's and  $t$ 's by means of a linear extrapolation shown in Fig.19. The extrapolation will be useful in formulation of a coordination problem.

- **Shorthand:  $z \equiv r$  or  $t$**
- **Lagrange multipliers  $\lambda$  from**

$$\lambda = - \left[ \nabla_k C^T \nabla_k C \right]^{-1} \nabla_k C^T \nabla_k F \quad (1)$$

where  $\nabla_k = \frac{d(\ )}{dX^k}$ ;  $C = \{C^p\}$ ;

- **Optimum sensitivity derivative of  $F$  simplifies to**

$$\frac{dF}{dz_i} = \lambda \frac{dC}{dz_i} \quad (2)$$

because  $\frac{\partial F}{\partial z_i} \equiv 0$  (3)

- **Extrapolation of  $F$  w.r.t. the  $z$ 's**

$$F = F^o + \sum_i \frac{dF}{dz_i} \cdot \Delta z_i \quad (4)$$

Figure 19

## COORDINATION OPTIMIZATION PROBLEM (COP).

In the coordination problem we seek new values of the coefficients  $r$  and  $t$ , adjusted so as to further reduce the objective  $F$ . In view of the linear extrapolation of  $F$  introduced in the previous figure, the problem is a simple case of linear programming shown below. The constraints in Eq.2 represent the division of responsibility for the constraint violation reduction allocated to various SSO's, and the constraints in Eq.3 pertain to the constraint violation-oversatisfaction trades among the SSO's. Since the  $t$ 's may be positive and negative, they would have to be expressed as differences of positive variables, if a standard form of linear programming were used to solve the problem. The move limits in Eq.5 and 6 may be needed due to nonlinearities of the original problem.

Execution of the COP follows every round of the SSO's in an iterative fashion. In the first COP execution, the  $r$ 's may be initialized as suggested in the Appendix and the  $t$ 's are initialized to zero. In every subsequent execution, the  $r$ 's and  $t$ 's are initialized to the terminal values from the previous COP execution. Judgmental intervention into the setting of the new  $r$ 's and  $t$ 's is quite acceptable, indeed, anticipated as a result of a teamwork among the groups responsible for the individual SSO's.

The result of the COP execution is a new set of the  $r$ 's and  $t$ 's to be used in the next SSO's. The adjustment of the  $r$ 's and  $t$ 's to the new values amounts to a reassignment of the responsibility for eliminating the constraint violations among the SSO's and to issuing a new set of instructions about trading the constraint violations-oversatisfactions among these SSO's. The expected result is a reduced value of  $F$  in the next round of SSO's.

$$\min_{r, t} F(r_k^p, t_k^p)$$

$$F = F^0 + \sum_p \sum_k \frac{dF}{dr_k} \Delta r_k^p + \sum_p \sum_k \frac{dF}{dt_k} \Delta t_k^p; p \text{ and } k = 1, NSS \quad (1)$$

subject to:

$$\sum_k r_k^p = 1 \quad (2)$$

$$\sum_k t_k^p = 0 \quad (3)$$

$$0 \leq r_k^p \leq 1 \quad (4)$$

$$L_{rk}^p \leq r_k^p \leq U_{rk}^p \quad (5) \quad L_{tk}^p \leq t_k^p \leq U_{tk}^p \quad (6)$$

Figure 20

## SYSTEM OPTIMIZATION PROCEDURE - BIRD EYE VIEW

The above operations form an iterative procedure shown below in a Chapin-format flowchart. Appendix provides more detail on the  $r$  initialization, special provisions for the case of an infeasibility remaining at the conclusion of the SSO's, and the usage of the coefficients  $r$ ,  $t$ , and  $s$ .

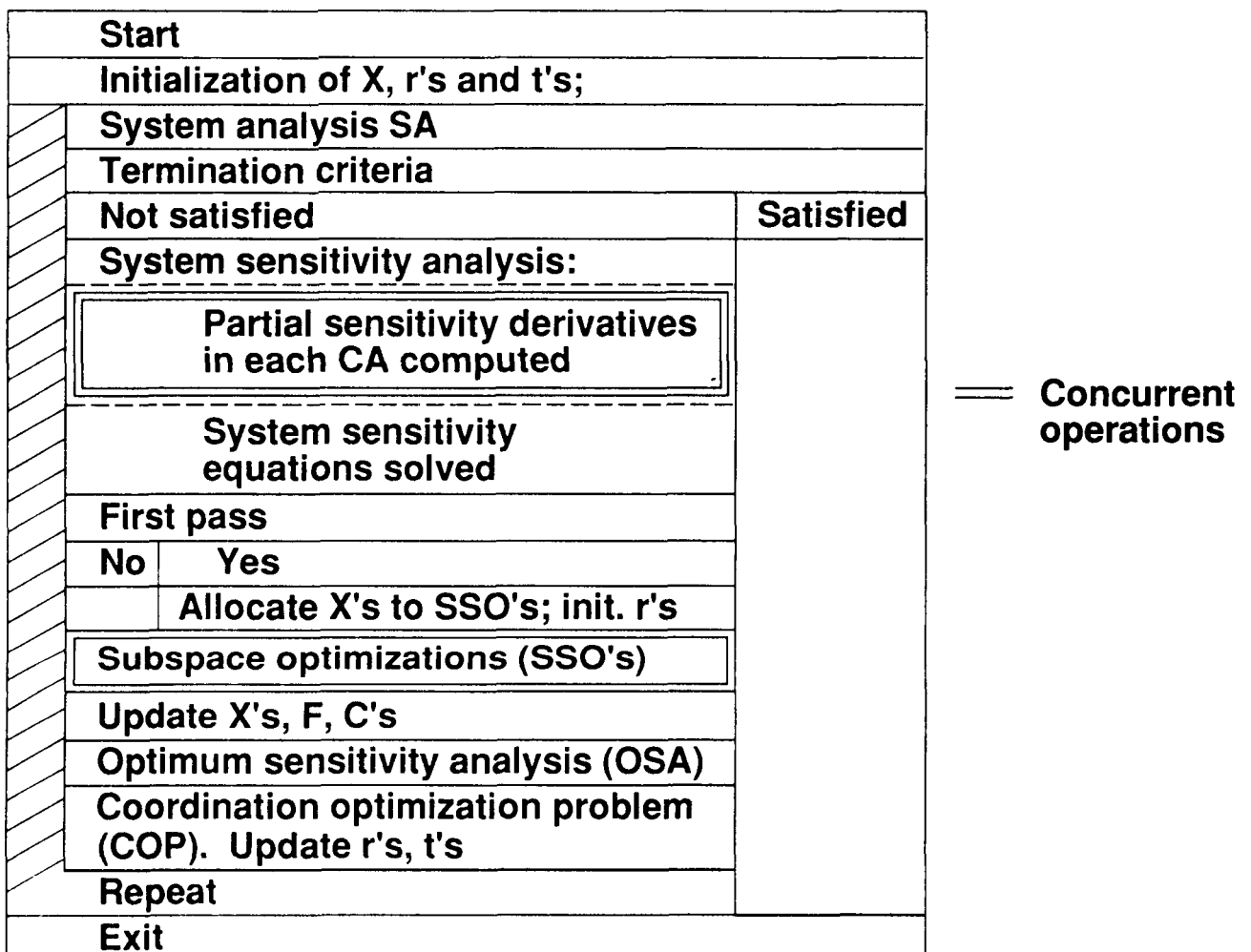

Figure 21

## DEMERITS AND MERITS

The procedure proposed above has not been tested yet, but some demerit/merit remarks (demerits first to end on a positive) may be offered on the basis of experience with other decomposition-based algorithms.

- **DEMERITS**

- **LINEARIZATION MAY REQUIRE NARROW MOVE LIMITS.**
- **ACTIVE CONSTRAINT SWITCHING MAY CAUSE ERRORS IN OPTIMUM SENSITIVITY DERIVATIVES.**

- **MERITS**

- **EFFICIENCY: NO FULL SYSTEM ANALYSIS FOR EACH SUBSPACE.**
- **COUPLINGS REDUCED TO SENSITIVITY ANALYSIS AND LP OPTIMIZATION.**
- **MODULARITY**
- **SPECIALIZED METHODS ADMISSIBLE IN SENSITIVITY AND SUBSPACE OPTIMIZATIONS.**
- **SUBSPACE OPTIMIZATIONS MAY CORRESPOND TO SPECIALTY GROUPS.**
- **GROUPS COMMUNICATION PRECISELY DEFINED.**
- **CONCURRENT SENSITIVITY ANALYSES AND SUBSPACE OPTIMIZATIONS.**
- **HUMAN JUDGMENT AND INTERVENTION ADMISSIBLE.**
- **RECURSIVITY: ANY CA MAY BE A COUPLED SYSTEM ITSELF.**

## ALTERNATIVE: LINEAR PROGRAMING WITH RESPECT TO X

An obvious alternative to the above procedure is to use the system sensitivity derivatives as a basis for linearizing the entire system optimization problem with respect to X without decomposing it into the subspace optimizations (SSO's), thus eliminating the coordination optimization (COP) and the optimum sensitivity analyses (OSA) needed for it. That would reduce the flowchart to the one shown below.

This alternative is attractive for its simplicity, and the experience reported in ref.10 with a similar scheme has been encouraging. However, the alternative forces the use of approximate information across the board while the procedure proposed herein allows the optimization to access exact analysis directly and relies on the linear extrapolation only insofar as the evaluation of the coupling effects is concerned, hence, its convergence is expected to be faster. Also, the alternative loses the advantage of being able to use specialized methods and human judgment in the subspace optimizations and the managerial convenience of having these optimizations performed by the groups into which a design organization splits naturally.

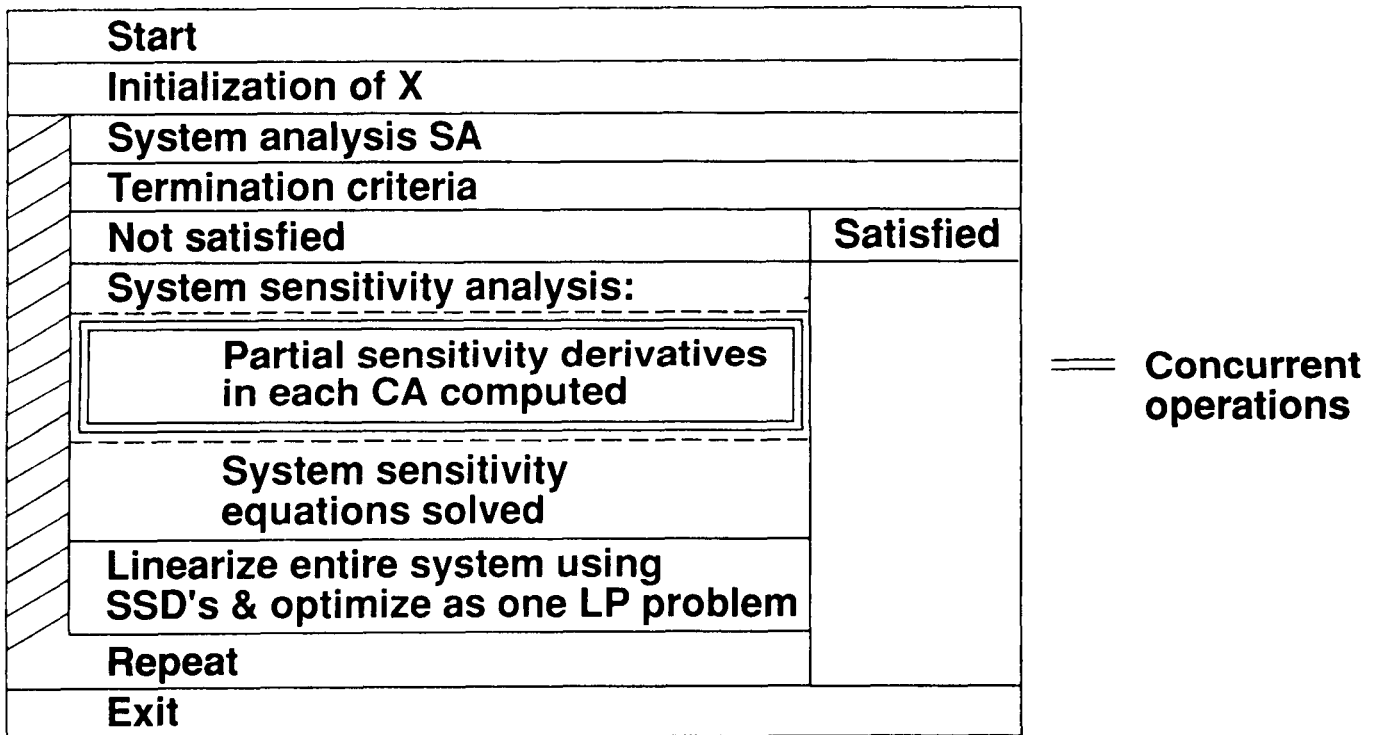

Figure 23



## CONCLUSIONS

Optimization of a large and complex engineering system has been considered in a design organization setting that requires the work be divided among the groups of specialists representing disciplines and physical subsystems. Each group's task may be coupled to any other so that the system is laterally coupled (a network system) and its optimization problem does not lend itself to the hierarchic decomposition previously introduced in literature.

A new, non-hierarchic decomposition is formulated for this system optimization. Its ingredients are system analysis, system sensitivity analysis, temporarily decoupled optimizations performed in the design subspaces corresponding to the disciplines and subsystems, and a coordination optimization concerned with the distribution of responsibility for the constraint satisfaction and design trades among the disciplines and subsystems. The approach amounts to a variation of the well-known method of subspace optimization modified so that the analysis of the entire system is eliminated from the subspace optimization and the subspace optimizations may be performed concurrently. It is evident that for convex problems each iteration of the procedure improves the design in terms of either reducing the constraint violations or reducing the objective function if the constraints are satisfied. However, the procedure is based, in effect, on a linearization approach to a problem that may be, in the general case, non-linear, hence no problem independent assertions can be made regarding the procedure convergence.

No operational experience with the procedure is available as yet, hence this presentation is intended to be a blueprint for research development and it suggests a set of specifications for consideration in other developments addressing the same problem.

- **NEW, NON-HIERARCHIC DECOMPOSITION HAS BEEN FORMULATED FOR LATERALLY COUPLED (NETWORK) SYSTEM.**
- **IT IS BASED ON SYSTEM ANALYSIS, SENSITIVITY, INTERDISCIPLINARY SHARING OF THE RESPONSIBILITY FOR CONSTRAINT SATISFACTION, AND SEPARATE, TEMPORARILY DECOUPLED, CONCURRENT OPTIMIZATIONS.**
- **THE COUPLING IS REPRESENTED IN A COORDINATION PROBLEM FORMULATED AS LINEAR PROGRAMING.**
- **LINEARIZATION ERRORS ARE A POTENTIAL DRAWBACK.**
- **PROPOSED PROCEDURE IS RECURSIVE.**
- **IT IS COMPATIBLE WITH DIVISION OF DESIGN ORGANIZATION INTO SPECIALTY GROUPS.**
- **IT ALLOWS THE USE OF SPECIALIZED ANALYSIS AND OPTIMIZATION METHODS.**
- **PROPOSED PROCEDURE AWAITS IMPLEMENTATION AND TESTING**

Figure 24

## APPENDIX

### Initialization of the r Coefficients

The coefficients may be initialized on the basis of the sensitivity information so as to assign a greater responsibility for a cumulative constraint satisfaction to those SSO's that have relatively greater influence on that constraint. From the system sensitivity analysis (SSA) we know the derivatives of the cumulative constraints in each SSO. For the k-th SSO we have

$$(A1) \quad C_i^{pk} \equiv dC^p/dX_i^k$$

The above derivatives collected for all SSO's form a matrix

$$(A2) \quad J = [C_i^{pk}]; \text{ NXX} \times \text{NSS}$$

Consider the p-th column of the above matrix and select

$$(A3) \quad a^{pk} \equiv \max_i (|C_i^{pk}|)$$

Repeating the above for  $k = 1 \rightarrow \text{NSS}$ , we assemble the  $a^{pk}$ 's in a vector normalized such that

$$(A4) \quad v^p = \{a^{pk}/\max_k (a^{pk})\}$$

This vector has an element equal to a unity at the location where the maximal  $a^{pk}$  appeared and elements smaller than unity everywhere else. The vector is now scaled so that its elements add up to unity and renamed a vector of the coefficients  $r_k^p$

$$(A5) \quad r_k^p = (1/\sum_p v^p)v^p; \quad p = 1, \text{NSS}$$

Elements of the above vector of length NSS may be used as initial values for the  $r_k^p$  coefficients. The total number of the r coefficients for  $p = 1 \rightarrow \text{NSS}$  is  $\text{NSS}^2$ .

### Failure of Finding a Feasible Design in an SSO.

The procedure requires that each SSO ends with a feasible solution because the optimum sensitivity analysis that follows it is meaningful only at a constrained optimum. Because of the use of the move limits required by linearization it may not be possible to meet that requirement when beginning with an infeasible initial design.

In the above case, one possible way to circumvent the difficulty is to use a constraint relaxation technique described in ref.11. The technique temporarily relaxes the violated constraints to bring them to a critical state and thus satisfies the formalism of a constrained minimum. The relaxation is gradually removed in the subsequent iterations to yield design feasible in a true, physical sense.

Another solution readily available in the procedure itself is to reset temporarily an appropriate coefficient  $t$  to remove the offending constraint violation. That arbitrary resetting will have the same effect as the technique from ref.11 and it will cause a violation of the constraint that requires that all the  $tp_k$  coefficients summed over  $k$  add up to zero in the coordination optimization problem (COP). This violation will force a resetting of the  $t$  coefficients in the process of solving the COP toward satisfying the violated cumulative constraint by a collective influence of all the SSO's that affect it.

### **The $r$ , $t$ , and $s$ Coefficients in System Optimization Procedure.**

With the entire System Optimization Procedure laid out in a flowchart format, it may be illuminating to elaborate on the way the procedure is controlled by the coefficients  $r$ ,  $t$ , and  $s$ .

The simplest situation occurs when a  $C^P$  is found satisfied after the first SA. Then, its  $s^P$  is set to 0 and that, in conjunction with its  $t^P_k$ 's that always are initialized to 0, makes the SSO's to treat that constraint as an ordinary inequality constraint with 0 on the right hand side. It is likely that in at least one SSO that constraint will become critical. If so, its  $t^P_k$ 's will be adjusted in the COP and the adjusted values will be used in the next SSO's. If the constraint never becomes active in any SSO, its  $t^P_k$ 's remain dormant at the initial setting of 0.

If a  $C^P$  is found critical after the first SA, its  $s^P$  is set to 0 and in the next SSO's it is treated as an inequality constraint with 0 on the right hand side. Subsequently, its  $t^P_k$ 's will be adjusted in the COP, and the adjusted values will be used in the next SSO's.

If a  $C^P$  is found violated after the first SA, its  $s^P$  is set to 1 and its  $r^P_k$ 's initial values will be used in the SSO's. Had the SSO's operated on accurate information only, the constraint would have been driven to a critical status after the first execution of the SSO's and there would be no need to adjust its  $r^P_k$ 's in the next COP. However, due to the approximation errors incurred in the SSO's one cannot rule out that a  $C^P$  predicted satisfied or critical in the SSO's may turn out to be still violated after the next execution of the SA (this may occur also due to inability of finding a feasible design, as discussed in the preceding section of this Appendix). To prepare for that eventuality two actions are taken: the Optimum Sensitivity Derivatives w.r.t. all the  $r$  and  $t$  coefficients corresponding to that constraint are computed in the next OSA, and the constraint  $r^P_k$ 's are adjusted in the subsequent COP.

If the SA in the next pass reveals that the  $C^P$  is still violated, then the adjusted values of its  $r^P_k$ 's will be used in the next SSO to further improve the constraint satisfaction. If the  $C^P$  is found satisfied, then it undergoes the treatment described above for a satisfied or critical constraint.

It is apparent from the above that the COP is never executed with a full set of  $NSS^2$  variables  $r$  and  $NSS^2$  variables  $t$  because the  $s$ -switch makes the  $r^P_k$  and  $t^P_k$  mutually exclusive. That reduces the dimensionality of the COP.

On the other hand, the OSA is carried out for each SSO for a full set of the  $r$ 's and a full set of the  $t$ 's, at least at the beginning of the procedure until all the  $s$ -switches settle in their final settings. Using the full sets of  $r$ 's and  $t$ 's in OSA does not pose a computational cost problem since

the partial derivatives w.r.t. these coefficients are trivial to obtain.

## REFERENCES

1. Sobieszczanski-Sobieski, J.: A Linear Decomposition Method for Large Optimization Problems - Blueprint for Development. NASA TM 83248, Feb. 1982.
2. Sobieszczanski-Sobieski, J., James, B.B.; and Riley, M.F.: Structural Sizing by Generalized, Multilevel Optimization, AIAA J. Vol.25, No. 1, January 1987, p.139.
3. Wrenn, G. A.; and Dovi, A. R.: Multilevel Decomposition Approach to the Preliminary Sizing of a Transport Aircraft Wing; AIAA/ASME/ASCE/AHS 28th Structures, Dynamics, and Materials Conference, Monterey, Cal., April 6-8, 1987, AIAA Paper No.87-0714-CP. (publ. in AIAA J. of Aircraft pending).
4. Barthelemy, J. F. M.: Engineering Applications of Multilevel Optimization; paper presented at Second NASA/Air Force Symposium on Recent Advances in Multidisciplinary Analysis and Optimization, Sept. 28-30, 1988, Hampton, Virginia. Proceedings published as NASA CP-number pending.
5. Abdi, F.F.; Ide, H.; Shankar, V. J.; and Sobieszczanski-Sobieski, J.: Optimization for Non-linear Aeroelastic Tailoring Criteria, paper presented at Int'l Council for Aeronautical Sc., 16th Congress, Jerusalem, Aug.-Sept., 1988.
6. Sobieszczanski-Sobieski, J.; On the Sensitivity of Complex, Internally Coupled Systems; AIAA/ASME/ASCE/AHS 29th Structures, Structural Dynamics and Materials Conference, Williamsburg, Va, April 1988; AIAA Paper No CP-88-2378.
7. Kreisselmeier, G.; and Steinhauser, R.: Systematic Control Design by Optimizing a Vector Performance Index; International Federation of Active Control Symposium on Computer-Aided Design of Control Systems, Zurich, Switzerland, Aug. 29-31, 1979.
8. Sobieszczanski-Sobieski, J.; Barthelemy, J. M.F.; and Riley, K. M.: Sensitivity of Optimum Solutions to Problem Parameters; AIAA J, Vol.21, Sept. 1982, pp. 1291-1299.
9. Barthelemy, J. M. F.; and Sobieszczanski-Sobieski, J.: Optimum Sensitivity Derivatives of Objective Functions in Nonlinear Programming; AIAA J, Vol.22, No.6, June 1983, pp.913-915.
10. Vanderplaats, G. N.; Yang, Y. J.; and Kim, D. S.: An Efficient Multilevel Optimization Method for Engineering Design, AIAA/ASME/ASCE/AHS 29th Structures, Structural Dynamics and Materials Conference, Williamsburg, Va, April 1988; AIAA Paper No CP-88-2226.
11. Barthelemy, J. F. M.; and Riley, M. F.: Improved Multilevel Optimization Approach for the Design of Complex Engineering Systems; AIAA J., Vol.26, No.3, March 1988, pp. 353-360.



# Report Documentation Page

1. Report No. NASA TM-101494		2. Government Accession No.		3. Recipient's Catalog No.	
4. Title and Subtitle Optimization by Decomposition: A Step from Hierarchic to Non-Hierarchic Systems			5. Report Date September 1988		
			6. Performing Organization Code		
7. Author(s) Jaroslaw Sobieszczanski-Sobieski			8. Performing Organization Report No.		
			10. Work Unit No. 505-63-11		
9. Performing Organization Name and Address NASA Langley Research Center Hampton, VA 23665-5225			11. Contract or Grant No.		
			13. Type of Report and Period Covered Technical Memorandum		
12. Sponsoring Agency Name and Address National Aeronautics and Space Administration Washington, DC 20546-0001			14. Sponsoring Agency Code		
			15. Supplementary Notes Presented at Second NASA/Air Force Symposium on Recent Advances in Multidisciplinary Analysis and Optimization, Hampton, VA, September 28-30, 1988.		
16. Abstract <p>A new, non-hierarchic decomposition is formulated for system optimization that uses system analysis, system sensitivity analysis, temporary decoupled optimizations performed in the design subspaces corresponding to the disciplines and subsystems, and a coordination optimization concerned with the distribution of responsibility for the constraint satisfaction and design trades among the disciplines and subsystems. The approach amounts to a variation of the well-known method of subspace optimization modified so that the analysis of the entire system is eliminated from the subspace optimization and the subspace optimizations may be performed concurrently.</p>					
17. Key Words (Suggested by Author(s)) System analysis System sensitivity analysis Coordination optimization			18. Distribution Statement Unclassified - Unlimited Subject Category 05		
19. Security Classif. (of this report) Unclassified		20. Security Classif. (of this page) Unclassified		21. No. of pages 28	22. Price A03