

NASA Contractor Report 4201

Gear Optimization

G. N. Vanderplaats, Xiang Chen,
and Ning-tian Zhang

GRANT NAG3-683
DECEMBER 1988

The NASA logo, consisting of the word "NASA" in a bold, sans-serif font.

NASA Contractor Report 4201

Gear Optimization

G. N. Vanderplaats, Xiang Chen,
and Ning-tian Zhang
University of California
Santa Barbara, California

Prepared for
Lewis Research Center
under Grant NAG3-683



National Aeronautics
and Space Administration

Scientific and Technical
Information Division

1988

CONTENTS

	<u>Page</u>
LIST OF SYMBOLS	<i>iv</i>
1.0 INTRODUCTION	1
2.0 NUMERICAL OPTIMIZATION CONCEPTS	2
3.0 THE COPES/ADS OPTIMIZATION PROGRAM	4
4.0 SPUR GEAR ANALYSIS AND OPTIMIZATION	5
4.1 THE SPUR GEAR PROGRAM	20
4.2 PARAMETERS CONTAINED IN THE GLOBAL COMMON BLOCK	21
4.3 DESIGN EXAMPLES	27
5.0 SPIRAL BEVEL GEAR ANALYSIS AND OPTIMIZATION	31
5.1 THE SPIRAL BEVEL GEAR PROGRAM	44
5.2 PARAMETERS CONTAINED IN THE GLOBAL COMMON BLOCK	44
5.3 DESIGN EXAMPLES	48
6.0 SUMMARY	53
7.0 REFERENCES	55

PRECEDING PAGE BLANK NOT FILMED

Symbols

W_n	normal load (lb)
ϕ	pressure angle (deg)
W_t	tangential load (lb) $W_t = W_n \cdot \cos\phi$
N_1	the number of pinion teeth
N_2	the number of gear teeth
P	diametral pitch (1/in)
P_b	base pitch, (in/tooth), $P_b = \pi \cos\phi / P$
r_1	pitch radius of pinion (in) $r_1 = N_1 / 2P$
r_2	pitch radius of gear (in) $r_2 = N_2 / 2P$
r_{a1}	addendum circle radius of pinion (in) $r_{a1} = r_1 + 1/P$
r_{a2}	addendum circle radius of gear (in) $r_{a2} = r_2 + 1/P$
r_{b1}	base circle radius of pinion (in) $r_{b1} = r_1 \cdot \cos\phi$
r_{b2}	base circle radius of gear (in) $r_{b2} = r_2 \cdot \cos\phi$
C	center distance (in) $C = r_1 + r_2$
a	addendum (in) $a = 1/P$
b	dedendum (in) $b = 1.25/P$
f_1	face width of pinion (in)
f_2	face width of gear (in)
f	face width in contact (in) $f = \min(f_1, f_2)$
ρ_A	density of pinion (lbm/in ³)
ρ_B	density of gear (lbm/in ³)
E_1, E_2	Young's modulus
μ_1, μ_2	Poisson's ratio
G	torsional modulus of elasticity
n_p	speed of pinion (rpm)
n_g	speed of gear (rpm) $n_g = N_1 / N_2 \cdot n_p$
V	pitch line velocity (in/sec) $V = \pi r_1 / 30 \cdot n_p$
ρ_1, ρ_2	curvature radius (in)
V_1, V_2	rolling velocity at point of contact (in/sec) $V_1 = \pi n_p / 30 \cdot \rho_1$ $V_2 = \pi n_g / 30 \cdot \rho_2$

1.0 INTRODUCTION

The design of gears is a highly complicated task, and the need to develop light weight, quiet and more reliable designs has resulted in a variety of changes in the design process. Very little published work is available on the subject of gear optimization. One exception is the work of Savage and co-workers [1], who present a method for the optimum design of gears with the object of minimizing size and weight. Their approach consists of comparing several candidate designs to obtain the best design and clearly this provides little assurance of obtaining a true optimum design. Also, identifying the best design using graphical methods becomes tedious once the number of design variables exceeds two. Therefore, a more general and systematic approach to gear design is desirable.

Here, mathematical programming techniques, commonly referred to as numerical optimization methods, are investigated to provide a reliable design methodology for gears. These techniques offer a logical approach to design automation and also can handle a wide variety of design variables and constraints which are difficult to visualize using graphical methods [2].

As part of this study, two gear optimization programs have been developed, one for spur gears and one for spiral bevel gears. The programs evaluate a wide variety of functions required by the optimizer. Typical design variables include the number of teeth, diametral pitch and face width. Design objectives may be minimum weight, minimum dynamic load factor or maximum gear life, as examples. Constraints may be imposed on loading or Hertzian stress, volume, and tooth velocity as examples. Also, it should be noted that objective and constraint functions are interchangeable. It is possible to minimize dynamic load factor with a required life or, alternatively, to maximize life with a bound on load factor.

In this report, the basic concepts of numerical optimization, as a gear design tool, are outlined first. Next, the COPES/ADS optimization program is briefly described. This program was used as the optimization tool throughout this study. The particular advantage

of this program is that the user is free to choose different design variables, objective function and constraint functions using input data when the program is executed, without modifying the program itself. The analysis capabilities developed here for spur gear and spiral bevel gear design are described next. It is important to note that these programs perform analysis only, and can be used for that purpose, without optimization. They have been written in the form needed to couple them to the COPES/ADS program when optimization is desired. When discussing each of these analyses capabilities, design examples are given to demonstrate their application in the optimization mode. Finally, the results of this project are summarized and continuing research efforts are described

2.0 NUMERICAL OPTIMIZATION CONCEPTS

The constrained optimization problem is mathematically stated as follows [1]

$$\text{Minimize (or maximize)} \quad F(X) \quad (1)$$

$$\text{Subject to} \quad g_j(X) \leq 0 \quad j = 1, m \quad (2)$$

$$h_k(X) = 0 \quad k = 1, l \quad (3)$$

$$X_i^l \leq X_i \leq X_i^u \quad i = 1, n \quad (4)$$

Where, $F(X)$ is referred to as the objective function. $g_j(X)$ are inequality constraint functions and $h_k(X)$ are equality constraint functions. $X_i, i=1, n$, are design variables. Equation (4) defines side constraints which impose limits on the region of search for the optimum.

A typical optimization problem for spur gear design can be stated as

Maximize	Life
Subject to	1) Dynamic load
limits on	2) Bending strength

- 3) Surface durability
- 4) Scoring
- 5) Weight
- 6) Gear size
- 7) Contact ratio
- 8) Involute interference
- 9) Width to diameter ratio

Alternatively, the dynamic load factor might be minimized with a lower bound constraint on life. Using COPES [3] and ADS [4,5], only input data needs to be changed for different problems.

Design Variables

The key element in formulating an optimization problem is the selection of the independent design variables that are necessary to characterize the design of the system. Normally, it is good to choose those variables that have a significant impact on the objective function. Based on this criterion, the number of teeth on the pinion and gear, N_1 and N_2 , the diametral pitch P and facewidth of the pinion and gear, f_1 and f_2 are typically chosen as the design variables. Since present optimization techniques do not deal well with integer variables, N_1 and N_2 are treated as a continuous variables in the optimization. The final answer can be rounded to the nearest integer value.

In principal, any input parameter to the gear analysis program can be taken as a design variable. The input data to the COPES/ADS program defines the number and identity of the design variables at run time. Also, design variables may be "linked" so that, for exampe $N_2 = 3 * N_1$ would assure a 3 to 1 gear reduction.

Objective Functions

The surface pitting fatigue life of a gear set in mesh and the dynamic load on a gear tooth are the objective functions in life maximization problem and dynamic load

minimization problem, respectively. Other objective functions may be size, weight, or tooth velocity as examples.

Constraints

Just as any response quantity calculated by the gear analysis program can be treated as the design objective, so can any quantity be treated as a constraint. As listed above, typical constraints here include limits on bending strength, surface durability, scoring, weight, size, contact ratio, interference and width-to-diameter ratio. Also, life and dynamic load can be treated interchangeably as objective or constraint functions. All that is needed to change the definition of the objective or constraint functions or the bounds on the constraints, is to change the input data to the COPES/ADS program.

3.0 THE COPES/ADS OPTIMIZATION PROGRAM

The COPES/ADS optimization program [3-5] was used in this study as the design tool, coupled with the spur gear or bevel gear analysis. The ADS program is a general purpose optimization program containing a variety of modern nonlinear programming algorithms. The COPES program is a control program which acts as the interface between ADS and the user-supplied analysis.

The basic concept of using COPES/ADS is that the user must supply an analysis program in subroutine form, called ANALIZ. The analysis is separated into three parts, being INPUT, EXECUTION, and OUTPUT. All parameters in the analysis that may be design variables, objective functions or constraints are contained in a single labeled common block called GLOBCM. The ordering of the information in GLOBCM is arbitrary.

The entries into the GLOBCM common block are treated as a set of sequential information to be accessed by COPES and the input data to COPES refers to these entries by their location. For example, the input to COPES may tell the program to minimize the value of entry number 3, while locations 1, 6 and 21 define three design variables. Finally,

locations 30 through 35 and locations 7 and 2 can be constrained. The details of how the data is input to the program are given in reference 3.

The key to using the COPES/ADS program is that it provides the designer a great deal of flexibility in choosing the design variables, objective and constraints, and that no program modifications are needed between design runs. It is only necessary to change the input data. This allows the designer to compare a variety of optimized designs, as opposed to the usual single variable trade-off studies. Also, the program is in no way limited to the analysis of spur and bevel gears described here, but is applicable to any design problem for which to ANALIZ subroutine is available.

4.0 SPUR GEAR ANALYSIS AND OPTIMIZATION

One of the design capabilities developed as part of this study is for spur gears. The study began by converting the TELSGE program, provided by NASA Lewis Research Center, to a subroutine ANALIZ and gaining experience in design for life maximization. This gear program does not include many of the constraints that must be considered by optimization, such as bending strength and scoring. However, TELSGE provided an excellent starting point for development of a more detailed program for use in optimization. The basic analysis capabilities of that program are described here and examples are given to demonstrate its capabilities. The purpose here was not to develop new analytical models for gears, but rather to identify and program good models into a general design program. The program is written in modular form so that any of the component parts can be modified and updated in the future.

Analytical Model for the Life of Spur Gears

The life of spur gears is calculated from an analytical model developed by NASA Lewis Research Center, which is programmed in subroutine LIFESG [6-8]. The basic gear geometry with geometrical parameters is shown in figures 1 through 4.

Here, it is assumed that the life of spur gears is mainly determined by the surface pitting fatigue failure caused by repeated applications of high surface contact stress.

The life of a single pinion tooth in millions of pinion rotations with 90 percent probability of survival is given as

$$L_1 = KW_n^{-4.3} f^{3.9} \Sigma\rho^{-5} l_1^{-0.4} \quad (5)$$

where $\Sigma\rho$ is the curvature radius (in), determined by

$$\Sigma\rho = \frac{C \sin\phi}{r_{b1} \phi_{L1} (C \sin\phi - r_{b1} \phi_{L1})} \quad (6)$$

θ_{L1} is the roll angle corresponding to the lowest point of single tooth contact on the pinion where the maximum Hertzian stress is considered to occur

$$\theta_{L1} = \delta_1 + \beta_{L1} \quad (7)$$

and

$$\delta_1 = \frac{C \sin\phi - \sqrt{r_{a2}^2 - r_{b2}^2}}{r_{b1}} \quad (8)$$

$$\beta_{L1} = \frac{\sqrt{r_{a1}^2 - r_{b1}^2} + \sqrt{r_{a2}^2 - r_{b2}^2} - C \sin\phi - P_b}{r_{b1}} \quad (9)$$

In equation (5), l_1 is the involute profile arc length of the pinion (in)

$$l_1 = r_{b1} \beta_{H1} (\delta_1 + \beta_{L1} + \frac{1}{2} \beta_{H1}) \quad (10)$$

where,

$$\beta_{H1} = \frac{2p_b - (\sqrt{r_{a1}^2 - r_{b1}^2} + \sqrt{r_{a2}^2 - r_{b2}^2} - C \sin \phi)}{r_{b1}} \quad (11)$$

Here, l_1 is calculated as the involute length across the heavy load zone as a justifiable simplification.

For a single gear tooth, the life in millions of pinion rotations with 90 percent probability of survival

$$L_{2p} = \left(\frac{N_2}{N_1}\right) \left(\frac{l_2}{l_1}\right)^{-\frac{1}{e}} L_1 \quad (12)$$

where, e is the Weibull exponent which is taken as 2.5. l_2 is the involute profile arc length of the gear (in) which is calculated similarly to l_1

$$l_2 = r_{b2} \beta_{H2} (\delta_2 + \beta_{L2} + \frac{1}{2}\beta_{H2}) \quad (13)$$

$$\delta_2 = \frac{C \sin \phi - \sqrt{r_{a1}^2 - r_{b1}^2}}{r_{b2}} \quad (14)$$

$$\beta_{L2} = \frac{\sqrt{r_{a1}^2 - r_{b1}^2} + \sqrt{r_{a2}^2 - r_{b2}^2} - C \sin \phi - P_b}{r_{b2}} \quad (15)$$

$$\beta_{H2} = \frac{2p_b - (\sqrt{r_{a1}^2 - r_{b1}^2} + \sqrt{r_{a2}^2 - r_{b2}^2} - C \sin \phi)}{r_{b2}} \quad (16)$$

For a pinion alone, the life in millions of pinion rotations with 90 percent probability of survival

$$L_p = N_1^{-1/e} L_1 \quad (17)$$

For a gear alone,

$$L_{Gp} = N_2^{-1/e} L_{2p} \quad (18)$$

The life of gear set in mesh in millions of pinion rotations, with 90 percent probability of survival is

$$L_M = \left\{ \left(\frac{1}{L_p} \right)^e + \left(\frac{1}{L_{Gp}} \right)^e \right\}^{-\frac{1}{e}}$$

or

$$L_M = \left\{ N_1 \left(\frac{1}{L_1} \right)^e + N_2 \left(\frac{1}{L_{2p}} \right)^e \right\}^{-\frac{1}{e}} \quad (19)$$

Dynamic Load

Dynamic load on a spur gear tooth is calculated by using Buckingham's solution [9,10], expressed as

$$W_d = W_t + \sqrt{f_a (2f_2 - f_a)} \quad (20)$$

where, f_a is the acceleration load which is a function of f_1 , the force needed to accelerate rigid bodies through the critical error, and f_2 , the force required to do the work of deforming the tooth by elastic deformation equal to the amount of the critical mesh error,

$$f_a = f_1 \cdot f_2 / (f_1 + f_2) \quad (21)$$

$$f_1 = [\tan\phi (1 - \cos\phi)/150\phi^2] [(1/r_1) + (1/r_2)] mV^2 = HmV^2 \quad (22)$$

$$f_2 = W_t [(e/d) + 1] \quad (23)$$

and m is the effective mass at pitch line of gears

e is the measured error on pair of mating teeth

d is the total deformation of mating teeth under applied load

For 20-deg full-depth form,

$$d = 9.00 (W_t / f) \left[\frac{1}{E_1} + \frac{1}{E_2} \right] \quad (24)$$

In equation (22)

$$m = m_1 m_2 / (m_1 + m_2) \quad (25)$$

$$m_1 = m_p + m_b \quad (26)$$

$$m_2 = m_g + m_d \quad (27)$$

Where, m_1 and m_2 are effective masses acting at pitch line of pinion and gear, respectively.

m_p and m_g are effective masses of pinion blank at r_1 and gear blank at r_2 , respectively.

$$m_p = \frac{\pi\rho}{2} \cdot r_{a_1}^4 \cdot f_1 \quad (28)$$

$$m_g = \frac{\pi\rho_B}{2} r_{a_2}^4 \cdot f_2 \quad (29)$$

$$m_b = (\sqrt{B_1^2 + 4A_1C_1} - B_1) / 2A_1 \quad (30)$$

$$A_1 = Hm_{a_1} V^2 \quad (31)$$

$$B_1 = (m_p + m_2) A_1 + em_2 Z_1 \quad (32)$$

$$c_1 = em_{a_1} \cdot m_2 Z_1 \quad (33)$$

$$m_d = (\sqrt{B_2^2 + 4A_2C_2} - B_2) / 2A_2 \quad (34)$$

$$A_2 = Hm_{a_2} V^2 \quad (35)$$

$$B_2 = (m_g + m_1) A_2 + em_1 Z_2 \quad (36)$$

$$C_2 = em_{a_2} m_1 Z_2 \quad (37)$$

where, m_{a_1} and m_{a_2} are full effective masses of connected bodies at r_1 and r_2 , respectively.

$$m_{a_1} = m_p + \frac{\pi\rho_A}{32} \cdot d_{f_1}^4 \cdot L_1 \quad (38)$$

$$m_{a_2} = m_g + \frac{\pi\rho_B}{32} d_{f_2}^4 \cdot L_2 \quad (39)$$

where, d_{f_1} and d_{f_2} are diameters of shaft corresponding to pinion and gear, respectively.

L_1 and L_2 are length of shaft corresponding to pinion and gear, respectively.

Z_1 and Z_2 are elasticity factors of shaft corresponding to pinion and gear, respectively.

$$Z_1 = \pi d_{f_1}^4 \cdot G / (32r_1^2 \cdot L_1) \quad (40)$$

$$Z_2 = \pi d_{f_2}^4 \cdot G / (32r_2^2 \cdot L_2) \quad (41)$$

Subroutine DYLOAD is programmed to calculate the dynamic load.

Bending Strength

In order to avoid gear tooth breakage, the bending stress of a gear tooth may not exceed the allowable tooth stress.

The bending stress is calculated by using the AGMA formula [11].

$$\sigma = \frac{W_t P}{K_v f \cdot J} \quad (42)$$

where, K_v is dynamic factor.

J is AGMA geometry factor.

Since the dynamic load W_d can be calculated by equation (20), equation (42) can be converted to

$$\sigma = \frac{W_d P}{fJ} \quad (43)$$

AGMA geometry factor J for external spur gear teeth is determined from the analytical model presented by R.G. Mitchiner and H.H. Mabie [12].

$$J = \frac{Y}{K_f \cdot m_N} \quad (44)$$

where,

Y is the Lewis form factor.

K_f is the stress concentration factor.

m_N is the load-sharing ratio.

The m_N may be taken as the profile contact ratio m_P

$$m_N = m_P = \frac{(\sqrt{r_{a_1}^2 - r_{b_1}^2} + \sqrt{r_{a_2}^2 - r_{b_2}^2} - c \sin \phi)P}{\pi \cos \phi} \quad (45)$$

K_f is defined as

$$K_f = H + \left(\frac{T}{r}\right)^L + \left(\frac{T}{R_c - y_E}\right)^M \quad (46)$$

where, $H = 0.34 - 0.4583662 \phi$ (47)

$L = 0.316 - 9.4583662 \phi$ (48)

$M = 0.290 + 0.4583662 \phi$ (49)

$r = r_f + (b - r_f)^2 / (R + b - r_f)$ (50)

R = pitch radius.

r_f = fillet radius on hob tip.

T = tooth width between points of tangency of parabola and root fillets.

R_c = radius from center of gear to apex of parabola.

$$r_f = \frac{1}{1 - \sin \phi} \left(\frac{\pi}{4p} \cos \phi - b \sin \phi \right) \quad (51)$$

$$R_c = \frac{R \cos \phi}{\cos\{\phi_A - [\frac{\pi}{2N} + \text{inv}\phi - \text{inv}\phi_A]\}} \quad (52)$$

$$\text{inv}\phi = \tan\phi - \phi \quad (53)$$

$$\phi_A = \tan^{-1} \left(\frac{\sqrt{1 - \left[\frac{R}{R+a} \cos \theta\right]^2}}{\frac{R}{R+a} \cdot \cos \theta} \right) \quad (54)$$

where, θ is calculated by using Newton's method.

$$\theta_{i+1} = \theta_i - \frac{f(\theta_i)}{f'(\theta_i)} \quad (55)$$

$$f(\theta) = m_{JE} + \frac{2(R_c - y_E)}{X_E} \quad (56)$$

$$m_{JE} = - \frac{1 + \left(\frac{b - r_f}{R\theta}\right) \tan(\beta + \theta)}{\left(\frac{b - r_f}{R\theta}\right) - \tan(\beta + \theta)} \quad (57)$$

$$\beta = \frac{\pi}{N} \quad (58)$$

$$X_E = (R - b + r_f) \sin(\beta + \theta) - R\theta \cos(\beta + \theta) - \frac{r_f}{\sqrt{(b - r_f)^2 + R^2\theta^2}} \\ [(b - r_f) \sin(\beta + \theta) + R\theta \cos(\beta + \theta)] \quad (59)$$

$$y_E = (R - b + r_f) \cos(\beta + \theta) + R\theta \sin(\beta + \theta) + \frac{r_f}{\sqrt{(b - r_f)^2 + R^2\theta^2}} \\ [R\theta \sin(\beta + \theta) - (b - r_f) \cos(\beta + \theta)] \quad (60)$$

$f(\theta)$ is calculated by using first-forward differential method. In equation (46),

$$T = 2X_E \quad (61)$$

Y is defined as

$$Y = \frac{P}{\frac{\cos \phi_L}{\cos \phi} \left[\frac{1.5}{X} - \frac{\tan \phi_L}{T} \right]} \quad (62)$$

where,

$$X = \frac{X_E^2}{R_c - y_E} \quad (63)$$

$$\phi_L = \tan^{-1} \left(\frac{\sqrt{1 - \left[\frac{R}{R+a} \cos \phi \right]^2}}{\frac{R}{R+a} \cos \phi} \right) - \frac{\pi}{2N} - \text{inv} \left[\tan^{-1} \left(\frac{\sqrt{1 - \left[\frac{R}{R+a} \cos \phi \right]^2}}{\frac{R}{R+a} \cos \phi} \right) \right] + \text{inv} \phi . \quad (64)$$

AGMA geometry factor J is calculated in subroutine GEOFAC. The bending stresses of pinion and gear tooth are calculated in subroutine BENDST.

The constraint condition for bending stress is

$$\sigma \leq \bar{\sigma} .$$

where, $\bar{\sigma}$ is material allowable stress.

Surface Durability

The gears must be designed so that the dynamic surface stresses are within the surface endurance limit of the material.

The surface contact stress (Hertzian stress) [11]

$$\sigma_H = \sqrt{\frac{W_d}{\pi f \cos \phi} \cdot \frac{(1/\rho_1) + (1/\rho_2)}{[(1-\mu_1^2)/E_1] + [(1-\mu_2^2)/E_2]}} \quad (65)$$

where, ρ_1 and ρ_2 are calculated at pitch point. The surface fatigue strength for steels is

$$S_c = (0.4 H_B - 10) \times 10^3 \text{ psi} \quad (66)$$

H_B is the Brinell hardness of the softer of the two contacting surfaces.

Modified by effective factors, the corrected fatigue strength

$$S_H = \frac{C_L C_H}{C_T C_R} S_C \quad (67)$$

where, C_L = life factor
 C_H = hardness - ratio factor
 C_T = temperature factor
 C_R = reliability factor.

The constraint condition for surface durability is

$$\sigma_H \leq S_H \cdot$$

σ_H and S_H are calculated in subroutine SURDUR.

Scoring

There are three constraint conditions to be considered for scoring failure. They are flash temperature limit, scoring criterion number and specific film thickness.

The flash temperature is expressed as [13,14]

$$T_f = T_b + \frac{C_f f_f W_t (V_1 - V_2)}{\cos \phi \cdot f(\sqrt{V_1} + \sqrt{V_2}) \sqrt{B/2}} \cdot \quad (68)$$

where, T_f = flash temperature, °F.
 T_b = temperature of blank surface in contact zone, °F.
 C_f = material constant for conductivity, density and specific heat. $C_f = 0.0528$.
 f_f = coefficient of friction. $f_f = 0.06$.
 B = width of band of contact.

$$B = 0.00054 \left[\frac{W_t \rho_1 \rho_2}{\cos \phi \cdot f (\rho_1 + \rho_2)} \right]^{0.5} \quad (69)$$

where, ρ_1 and ρ_2 are calculated at the contact point where the flash temperature is higher.

$$\text{The scoring criterion number} = \left(\frac{W_t}{f} \right)^{3/4} \cdot \frac{n_p^{1/2}}{p^{1/4}} \quad (70)$$

The critical scoring-criterion number

$$= 60T_b + 23000. \text{ Which is formulated from the table [14].} \quad (71)$$

The specific film thickness [13]

$$\lambda = \frac{h_{\min}}{\sigma} \quad (72)$$

$$\sigma = \sqrt{\sigma_p^2 + \sigma_g^2} \quad (73)$$

where, h_{\min} = minimum oil film thickness, in.

σ_p = pinion average roughness, rms.

σ_g = gear average roughness, rms.

The minimum elastohydrodynamic film thickness is [13,15]

$$h_{\min} = \frac{2.65 \alpha^{0.54} (v_o u)^{0.7} E'^{-0.03} R^{0.43}}{W^{0.13}} \quad (74)$$

where, α = pressure viscosity coefficient.

v_0 = absolute viscosity.

$$\frac{1}{E'} = \frac{1}{2} \left(\frac{1 - \mu_1^2}{E_1} + \frac{1 - \mu_2^2}{E_2} \right). \quad (75)$$

$$u = \frac{1}{2} (u_1 + u_2) \quad (76)$$

u_1 and u_2 are rolling velocities of pinion and gear at point of contact, respectively.

$$u_1 = \frac{\pi n_p}{30} \cdot \rho_1 \quad (77)$$

$$u_2 = \frac{\pi n_g}{30} \cdot \rho_2. \quad (78)$$

$$R = \frac{\rho_1 \rho_2}{\rho_1 + \rho_2}.$$

(ρ_1 and ρ_2 are calculated at the lowest point where the worst Hertzian stress is considered to occur.)

W = specific loading. It is taken as $\frac{W_t}{f}$, here.

To avoid the scoring failure, the flash temperature should be below a certain limit, the specific film thickness may not be less than 1.0, and the scoring number may not exceed the critical number.

These functions are calculated in subroutine FLASH, SCORING, FILMTH,

FLMFC.

Gear Weight and Size

In order to increase the life of gears or reduce the dynamic load on gear tooth without the cost of increasing the weight and the gear size, constraints may be placed on the weight of the pinion, gear and the gear mesh center distance C . Alternatively, one of these parameters may be taken as the design objective.

$$\text{Weight of the pinion} = \rho_A \cdot \pi r_1^2 \cdot f_1 \quad (79)$$

$$\text{Weight of the gear} = \rho_B \pi r_2^2 \cdot f_2 \quad (80)$$

$$\text{Gear mesh center distance, } c = r_1 + r_2 \quad (81)$$

Contact Ratio

The contact ratio

$$m_p = \frac{(\sqrt{r_{a_1}^2 - r_{b_1}^2} + \sqrt{r_{a_2}^2 - r_{b_2}^2} - C \sin \phi)P}{\pi \cos \phi} \quad (82)$$

For standard spur gears, m_p should be greater than 1.4 and is normally less than 2.0 [11,12].

Involute Interference

Involute interference occurs when the driving gear tooth makes contact with the driven tooth before the involute portion of the driving tooth comes within range. That is, when contact occurs below the base circle of the driver gears on the non-involute portion of the flank.

For no involute interference, a constraint condition is imposed [1].

$$C \sin \phi > \sqrt{r_{a_2}^2 - r_{b_2}^2} \quad (83)$$

$$N_{p_1} = \frac{C \sin \phi}{\sqrt{r_{a_2}^2 - r_{b_2}^2}} \quad (84)$$

Width to Diameter Ratio

For the tooth load to be uniform, a common criterion is to limit the length to diameter ratio of the line of contact [1].

This ratio is

$$\lambda_R = \frac{fP}{N_1} \quad (85)$$

An additional requirement is $N_1 \leq N_2$, since N_1 and N_2 are corresponding to pinion and gear, respectively.

4.1 The Spur Gear Program

The detail structure of COPEs and ADS will not be discussed here, since it has been already presented in References 3-5. The spur gear analysis subroutines include ANALIZ, TREAT, BENDST, GEOFAC, GEOFUN, GEODF, DYLOAD, SURDUR, SCORIN, FLASH, FILMSC, WEIGH, RATIOC, LIFESG, FILMTH and OUTPUT. ANALIZ is the subroutine required by COPEs such that the analysis subroutines could be coupled to COPEs. TREAT evaluates required items in terms of the initial values of design variables and constant data input by users. BENDST evaluates the bending stresses by using AGMA formula, where the required geometry factor J is calculated in routine GEOFAC. GEOFUN and GEODF evaluate functions and function gradients required in geometry

factor calculations, respectively. DYLOAD evaluates the dynamic loading on gear teeth using Buckingham's solution. SURDUR calculates the Hertzian stress to observe surface durability, while the scoring criterion number and the flash temperature are determined in SCORIN and FLASH, respectively. The ratio of film thickness to composite surface roughness is calculated in FILMSC, which is one of the parameters in scoring constraint conditions. WEIGH calculates the weight of gear mesh and RATIOC calculates the contact ratio. LIFESG calculates surface fatigue life of spur gear mesh, which is one of the objective functions. FILMTH calculates the minimum elastohydrodynamic film thickness. Finally, OUTPUT prints the results at each step.

4.2 Parameters Contained in the Global Common Block

In order to perform design operations, the COPES program must access the data in common block GLOBCM. The location in GLOBCM where a specified parameter resides must be defined in the COPES input data. The statement of the common block GLOBCM in this spur gear optimization design program is

```
COMMON /GLOBCM/LFM,WD,NTA,NTB,PD,FWAD,FWBD,CTAA,  
DSTBD(2),SST,CSORN,TEMFL,LAMDA,RATIO,WEIGHT(2),CENL,  
RATLD(2),AINTF,DNT
```

Where, LFM is the life of gear mesh in millions of pinion rotations, which is the value of the objective function in the life maximization problem.

WD is the dynamic load on gear tooth (lb.), which is the value of the objective function in dynamic load minimization problem.

NTA and NTB are the number of teeth of pinion and gear (in.), respectively, which are design variables.

PD is the diametral pitch (1/in.), which is one of the design variables.

FWAD and FWBD are the face width of pinion and gear (in.), respectively, which

are design variables.

CTAA is the pressure angle (deg.), which is an input constant.

DSTBD is an array having two elements. DSTBD(1) and DSTBD(2) are the maximum bending stresses acting on the tooth of pinion and gear (psi.), respectively. Here, the dynamic load is considered in the calculation.

SST is defined as the surface contact stress (Hertzian stress) minus the surface fatigue strength (psi.).

CSCORN is defined as the scoring criterion number minus the critical scoring criterion number.

TEMFL is the flash temperature (°F).

LAMDA is the specific film thickness.

RATIO is the contact ratio.

WEIGHT is an array having two elements. WEIGHT(1) and WEIGHT(2) are the weight of pinion and gear (lb.), respectively.

CENL is the gear mesh center distance (in.), which presents the size of the gear mesh.

RATLD is an array having two elements. RATLD(1) and RATLD(2) are the ratio of width to diameter of pinion and gear respectively.

AINTF is a constraint condition corresponding to involute interference, which is defined as

$$\text{AINTF} = c \sin \phi - \sqrt{r_{a_2}^2 - r_{b_2}^2}$$

AINTF should be greater than 0, since

$$c \sin \phi > \sqrt{r_{a_2}^2 - r_{b_2}^2}$$

DNT is defined as NTB minus NTA. DNT should not be less than 0, since the gear is always not less than the pinion.

DSTB, SST, CSCORN, TEMFL, LAMDA, RATIO, WEIGHT, CENL, RATLD, AINTF and DNT are values of constraint functions. The definitions of some terms have been explained previously.

Input Data Description

There are two parts of input data file. The first part corresponds to COPES; and the second part corresponds to the spur gear analysis subroutines. The details of the COPES input may be found in the COPES manual (3) and so are not described here.

Spur Gear Analysis Input Data

There are six rows of data in the second part input file. The form of the input data file is as follows:

NTA,NTB,PD,FWAD,FWBD,CTAA

TTLD,CYCLP

DENSA,DENSB,YMAD,YMBD,EPSA,EPSE,SRMS1,SRMS2

ERR,SHL1,SHL2,SHD1,SHD2

HARDB,CL,CH,CT,CK

ALPHA,VISD,BETA,TEMLUB

Where, NTA and NTB are the number of pinion and gear teeth, respectively.

PD is the diametral pitch (in.^{-1})

FWAD and FWBD are the face widths of pinion and gear, respectively (in.).

CTAA is the pressure angle (deg.).

TTLD is the normal load acting on gear tooth (lb.).

CYCLP is the pinion speed (r/s).

DENSA and DENSB are the material density of pinion and gear, respectively (lbm/in^3).

YMAD and YMBD are Young's modulus of pinion and gear, respectively (psi.).

EPSA and EPSB are Poisson's ratio of pinion and gear, respectively.

SRMS1 and SRMS2 are surface roughness corresponding to pinion and gear, respectively (microin.)

ERR is the measured error on pair of mating teeth (in.).

SHL1 and SHL2 are the lengths of shaft corresponding to pinion and gear, respectively (in.).

SHD1 and SHD2 are the diameters of shaft corresponding to pinion and gear, respectively (in.).

HARDB is the Brinell hardness, which is required in scoring observation.

CL, CH, CT, CK are the life factor, the hardness ratio factor, the temperature factor and the reliability factor, respectively. These factors are required in surface durability observation.

ALPHA is the pressure viscosity coefficient.

VISD is the viscosity (lb.s/in^2) at ambient temperature.

BETA is the temperature viscosity coefficient.

TEMLUB is the ambient temperature (deg. F).

ALPHA, VISD, BETA and TEMPLUB are required input data in film thickness calculation.

All of above input data are real number, including the number of teeth NTA and NTB.

Input Data Example: Life Maximization

The input data for a design example of the life maximization problem is presented in the following Table.

Table 1

\$ BLOCK A:
OPTIMIZATION DESIGN FOR LIFE OF SPUR GEARS
\$ BLOCK B:
2,3
\$ BLOCK C:
0,5,7,1000
\$ BLOCK D:
\$ BLOCK E:
\$ BLOCK F:
5,1,+1.0
\$ BLOCK G:
30.,50.,36.
8.,12.,8.
0.2,0.4,0.25
\$ BLOCK H:
1,3
1,4
2,5
3,6
3,7
\$ BLOCK I:
10
\$ BLOCK J:
9,10,1
0.,0.,180000.,0.
11,11,1
0.,0.,1.E15,0.
12,12,1
-1.E+10,0.,0.,
13,13,1
0.,0.,275.,0.
14,14,1
1.,0.,10.,0.
15,15,1
1.,0.,3.,0.
16,17,1
1.,0.,4.5,0.
18,18,1
3.5,0.,5.,0.
19,20,1
0.044,0.,0.056,0.
21,21,1
0.,0.,1.E15,0
\$ BLOCK R:
END

36.,36.,8.,0.25,0.25,20.
 386.3,5000.
 0.283,0.283,30000000.,30000000.,0.3,0.3,16.,16
 0.001,20.,20.,8.,8.
 620.,1.,1.,1.,1.25
 0.00013,0.0000018,7100.,120.

Input Data Examples: Dynamic Load Minimization

The input data for a design example of the dynamic load minimization problem is presented in Table 2.

Table 2

```

$ BLOCK A:
OPTIMIZATION DESIGN OF DYNAMIC LOADING OF SPUR GEAR TOOTH
$ BLOCK B:
2,5
$ BLOCK C:
0,5,7,1000
$ BLOCK D:
$ BLOCK E:
$ BLOCK F:
5,2,-1.0
$ BLOCK G:
30.,50.,36.
8.,12.,8.
0.2,0.4,0.25
$ BLOCK H:
1,3
1,4
2,5
3,6
3,7
$ BLOCK I:
10
$ BLOCK J:
9,10,1
0.,0.,180000.,0.
11,11,1
0.,0.,1.E15,0.
12,12,1
-1.E+10,0.,0.,0.
13,13,1

```

```

0.,0.,275.,0.
14,14,1
1.,0.,10.,0.
15,15,1
1.,0.,3.,0.
16,17,1
1.,0.,4.5,0.
18,18,1
3.5,0.,5.,0.
19,20,1
0.044,0.,0.056,0.
21,21,1
0.,0.,1.E15,0.
$ BLOCK R:
END
36.,36.,8.,0.25,20.
386.3,5000.
0.283,0.283,30000000.,30000000.,0.3,0.3,16.,16.
0.001,20.,20.,8.,8.
620.,1.,1.,1.,1.25
0.00013,0.0000018,7100.,120.

```

Program Operation

After compiling, FORTRAN file SPUR is linked with COPES and ADS to obtain the completed spur gear optimization design program, where, file SPUR includes subroutine ANALIZ, TREAT, BENDST, GEOFAC, GEOFUN, GEODF, DYLOAD, SURDUR, SCORIN, FLASH, FILMSC, WEIGH, RATIOC, OUTPUT, LIFESG and FILMTH, i.e.,

LINK SPUR, COPES, ADS

After linking, the input and output data file should be defined, then, the spur gear optimization design program could be run to obtain the optimal results.

4.3 Design Examples

Two optimization problems are considered here: life maximization and dynamic load minimization.

Life Maximization

The operation conditions are:

Speed (pinion RPM): 5000

Normal load (LbS): 386.3

Ambient temperature (°F): 120.0

Gear material constants	pinion	gear
Young's modulus (psi)	30×10^6	30×10^6
Poisson's ratio	0.3	0.3
Density (Lbm/in ³)	0.283	0.283

Lubrication constants

Viscosity at 170°F (lb. sec/in ²)	1.8×10^{-6}
Pressure-viscosity coefficient (in ² /lb)	1.3×10^{-4}
Temperature-viscosity coefficient (deg R)	7.1×10^3

Gear geometry constants	pinion	gear
RMS surface roughness (micin)	16.0	16.0
Pressure angle (deg)	20.0	20.0
Measured error (in.)	0.001	0.001
Length of shaft (in.)	20.0	20.0
Diameter of shaft (in)	8.0	8.0

Brinell hardness	620.0
Life factor C_L	1.0
Hardness-ratio factor C_H	1.0
Reliability factor C_K	1.25
Temperature factor C_T	1.0

The life maximization problem is

Maximize	$L(x)$	(Gear mesh life)
Subject to	1) $0 \leq \sigma$ (bending stress) ≤ 180000	
	2) σ_H (Hertzian stress) $\leq S_H$ (fatigue strength)	
	3) Scoring number \leq critical scoring number	
	4) $0 \leq T_f$ (Flash temperature) ≤ 275	
	5) $1 \leq \lambda$ (specific film thickness) ≤ 10	
	6) $1.4 \leq m_p$ (contact ratio) ≤ 2.0	
	7) $1.0 \leq W_p$ (pinion weight) ≤ 4.5	
	8) $1.0 \leq W_g$ (gear weight) ≤ 4.5	
	9) $3.5 \leq C$ (center distance) ≤ 5.0	
	10) $0.044 \leq \lambda_R$ (length to diameter ratio) ≤ 0.056	
	11) Np_1 (for no involute interference) ≥ 1	
	12) $N_1 \leq N_2$	

Side Constraints

- 1) $30 \leq X_1, X_2$ (the number of teeth) ≤ 60
- 2) $8 \leq X_3$ (diametral pitch) ≤ 12 .
- 3) $0.2 \leq X_4, X_5$ (facewidth) ≤ 0.4

the initial design was

$$N_1 = N_2 = 36, P = 8, f_1 = f_2 = 0.25 \text{ (in.)}$$

has a mesh life of 666.1 million pinion rotations.

The optimization algorithm used was the Modified Feasible directions method with polynomial interpolation with bounds for the one-dimensional search. After optimization, the final design has a mesh life of 1963.6 million pinion rotations.

The final value of the design variables are

$$N_1 = N_2 = 58.8 \quad P = 11.774 \quad f_1 = f_2 = 0.28 \text{ (in.)}$$

The initial and final dynamic loads, W_d , were 1141.1 and 1190.1, respectively.

Dynamic Load Minimization

For the dynamic load minimization problem, all the input constants, constraint conditions, side constraints and initial values of design variables are the same as in life maximization problem. Only the objective function becomes dynamic load W_d now.

That is

$$\text{Minimize} \quad W_d$$

the initial design has a dynamic load of 1141.1 lb.

After optimization, where the same optimization method as in life maximization problem is used, the final design has a dynamic load of 1089.2 lb.

The final value of the design variables are

$$N_1 N_2 = 39.8 \quad P = 8, \quad f_1 = f_2 = 0.219 \text{ (in.)}$$

Summary

It is seen from the results of these examples that the mesh life of spur gears can be increased significantly (195%) by increasing the number of teeth, diametral pitch and face width without any significant change in the weight and size of the gears. Meanwhile, all the constraints conditions considered here are satisfied.

On the other hand, the dynamic load on spur gear tooth is reduced only a little (4.6%) by increasing the number of teeth and decreasing face width. The reason may be that the dynamic load on gear tooth mainly depends on the dynamic parameters such as speed and measured error on pair of mating teeth rather than the geometric parameters which are design variables here.

The nature of the dynamic load optimization problem needs to be investigated further. More reasonable design variables are expected to be chosen such that the dynamic load can be minimized much more. Besides, the constraint conditions corresponding to new design variables need to be developed.

5.0 SPIRAL BEVEL GEAR ANALYSIS AND OPTIMIZATION

Spiral bevel gears have advantages than other bevel gears. The mesh of spiral bevel gears has a rolling contact. Since spiral bevel gears have curved oblique teeth, the contact is smooth and continuous from end to end. Also as a result of their overlapping teeth action, spiral bevel gears will transmit motion more smoothly than spur gears and other bevel gears thereby reducing noise and vibration which become especially noticeable at high loads and high speeds.

On the other hand, because of the complicated geometry of spiral bevel gear, the basic mechanisms which govern the major modes of spiral bevel gears are still not fully understood. Thus the design and analysis of a spiral bevel gear set remains a difficult problem.

The analysis presented is for the design of a set standard spiral bevel gear mesh. A typical objective is to maximize gear life without increasing gear weight. The transmitted horsepower, rpm of the pinion, and gear reduction ratio are given as input. A typical set of constraints includes bending fatigue, surface pitting, and scoring failure. Kinematic limits of face contact ratio, involute interference and other geometric limits are also considered.

The study here is based on a thorough study of the kinematics of the gear mesh, such as those by Buckingham [9]. A Tregolds approximation to calculate spiral bevel gear geometry is used. The study is also based on a standard spiral bevel gear set with dimensions of the AGMA.

The purpose is to establish an optimal design procedure for a set of standard spiral bevel gears which are given specified pinion speeds, input horsepower and gear reduction ratio.

Analytical Model for the Life of Spiral Bevel Gears

Dynamic Load Bending Strength

The basic geometrical parameters describing the spiral bevel gear are shown in figure 5. The fundamental equation for bending stress in a gear tooth was developed by Wilfred Lewis in 1893. The AGMA has modified the basic bending stress by several factors that deal with the characteristics of specific application as follows:

$$S_t = \frac{W_t K_o}{K_v} \cdot \frac{P_d}{F} \cdot \frac{K_s K_m}{J} \quad (86)$$

$$S_t \leq \text{sat} \cdot \frac{K_L}{K_T K_R} \quad (87)$$

where

W_t = tangential load at the pitch diameter of large end

$$W_t = \frac{126000}{n_p d_p} = \frac{H_p \times 33000}{V} \text{ (Lb)} \quad (88)$$

- n_p = Rpm of pinion (rpm)
- d_p = pitch diameter of pinion at large end (in)
- V = pitch line velocity (in/sec)
- H_p = input horsepower
- P_d = diametral pitch (1/in)
- F = face width (in)
- J = geometric factor for bending
- K_o = overload factor
- K_v = dynamic factor
- K_s = size factor

- K_m = load distribution factor
- K_L = life factor
- K_T = temperature factor
- K_R = safety factor
- S_t = calculated tensile stress at root of the teeth (psi)
- sat = allowable stress for material (psi)

Usually sat = 30000 psi for an aircraft power drive case [10]. In general, gears should be designed for equal stress on gear and pinion.

All of the K factors can be chosen in different cases by the user [10].

The geometry factor J is an index of the tooth geometry and stress concentration in the root fillet. It strongly depends on the cutting tool geometry. It is also an important factor in calculating the tensile stress.

The AGMA standard has given the geometry factor J for a spiral bevel gear tooth at shaft angle 90°, pressure angle 20°, spiral angle 35° graphically. In order to compute J for other cases, the polynomial approximation is used to obtain the J factor from the AGMA charts.

A linear polynomial equation is used as follows:

$$J = a_0 + a_1 N_p + a_2 N_G + a_3 N_p N_G \quad (89)$$

In order to determine the coefficients $a_0, a_1, a_2, a_3 \dots$, 5-10 points are chosen from each curve. Then, the least squares method is used to determine the a_0, a_1 . This gives

$$J = 0.09003 + 3.9145 \times 10^{-3} N_p + 2.544 \times 10^{-3} N_G - 3.2423 \times 10^5 N_p N_G \quad (90)$$

$$(12 \leq N_p \leq 100 \quad 12 \leq N_G \leq 100)$$

where N_p = number of teeth on pinion

N_G = number of teeth on gear

This equation is not only convenient for computer code, but also is quite accurate for calculating geometry factor J.

Pitting

Another mode of failure is called "pitting" of the tooth surfaces. It is caused by too high contact stress known as "Hertz stress" at the contact surface. Here we assume that the magnitude of Hertz stress is a reasonable measure of the tendency of the surface to pit.

In the AGMA standard, the Hertz stress can be calculated by the following formula

$$S_c = C_p \sqrt{\frac{W_t C_0 C_s C_m C_f}{C_v \cdot d \cdot F \cdot I}} \quad (91)$$

$$S_c \leq S_{ac} \frac{C_L C_H}{C_T C_R} \quad (92)$$

where

W_t = tangential load at the pitch diameter of large end (Lb)

C_p = elastic coefficient

$$C_p = \frac{1.5}{\pi \left(\frac{1 - \mu_p^2}{E_p} + \frac{1 - \mu_G^2}{E_G} \right)}$$

μ_p = Poisson's ratio for pinion

μ_G = Poisson's ratio for gear

- E_p = Young's module for pinion
- E_G = Young's module for gear
- d = pitch diameter for pinion at large end (in)
- F = face width (in)
- C_0 = factor overload
- C_s = size factor
- C_m = load distribution factor
- C_f = surface condition factor
- C_v = dynamic factor
- C_L = life factor
- C_H = hardness ratio factor
- C_T = temperature factor
- C_k = safety factor
- S_c = calculated Hertz stress (psi)
- S_{ac} = allowable Hertz stress (psi)
- $S_{ac} = (0.4H_B - 10) \times 100$ (psi)
- H_B = Brinell hardness of pinion

H_B can be the natural hardness of the material or the limit of the tooth hardening.

The geometry factor, I , depends on the radius of curvature at the point of contact and the load sharing between teeth. The AGMA standard has given the geometry factor I for a spiral bevel gear tooth at shaft angle 90° , pressure angle 20° , spiral angle 35° graphically. For the computer code, this number is obtained from the polynomial which fits the curve of the AGMA charts. The procedure is the same as for the geometry factor, J . The resulting polynomial equation is

$$I = 0.0680 - 1.0736 \times 10^{-3} N_p + 1.399 \times 10^{-3} N_G - 1.235 \times 10^6 N_p N_G \quad (93)$$

$$(12 \leq N_p \leq 50 \quad 15 \leq N_G \leq 100)$$

All of the c factors can be chosen by user [5].

Scoring

Besides breakage fatigue and pitting fatigue, the third mode of failure is scoring. Recently more attention has been paid to this phenomena. It usually occurs in high speed and high load conditions, with low viscosity lubricants when the overheating causes the oil film breakdown and the gear is kept in operation after pitting starts. This phenomena is also called metal-to-metal contact resulting in welding and tearing apart until the tooth surface is deteriorated. Actually, scoring is a lubrication failure, and is hard to analyze and predict. Research has reported that it is influenced by a combination of factors, such as pressure, sliding velocity, viscosity of the oil, temperature of the oil bath, properties of material and surface finish and treatment, etc.

There are many ways to predict scoring risk. Two design approaches will be given here. The one efficient method is based on flash temperature (called hot scoring). The other is based on oil-film thickness (called cold scoring).

The concept of flash temperature was first presented by Blok [16] as follows:

$$T_f = T_b + \Delta T \quad (94)$$

Where: T_b is the temperature of gear blank in the contact zone. It is difficult to estimate. Often the blank temperature is approximated as the average of the oil temperature entering and leaving the gearbox [13]. In this paper, we choose $T_b = 200^\circ\text{F}$. The increment of the

temperature, ΔT can be calculated as follows [13]:

$$\Delta T = Z_t \left(\frac{W_t}{F_e} \right)^{0.75} \cdot \frac{N_p^{\frac{1}{2}}}{P_d^{\frac{1}{4}}} \quad (95)$$

where

W_t = tangential load of the pitch diameter at large end (Lb)

F = face width (in)

n_p = rpm of pinion (Rpm)

P_d = diametral pitch (1/in)

Z_t = scoring geometry

$$Z_t = \frac{0.0175 (\sqrt{\rho_1} - \sqrt{\rho_2/MG}) P_d^{\frac{1}{4}}}{(\cos \phi_t)^{3/4} [\rho_1 \rho_2 / (\rho_1 + \rho_2)]^{1/4}} \quad (96)$$

(use absolute value of Z_t)

where

ϕ_t = transverse pressure angle $\tan \phi_t = \tan \phi / \cos \psi$

ψ = spiral angle

ϕ = normal pressure angle

MG = gear ratio

ρ_1 = the curvature of contact point for pinion

ρ_2 = the curvature of contact point for gear

(Note: Here we use the material that is steel on steel and take the coefficient of friction as 0.06).

Because scoring is considered most likely to occur at the lowest point of single tooth

contact on the pinion or the highest point of single tooth contact on the pinion, these two points are checked. Normally, scoring calculations are made for the pinion only and the gear is handled indirectly. If the pinion is safe the gear should be safe.

The formula used here to calculate the lower single tooth contact curvature for spur and helical gears at lowest single tooth contact is,

$$\rho_1 = \sqrt{r_0^2 - (r \cos \phi_t)^2} - p \cos \phi_t \quad (97)$$

$$\rho_2 = \cos \phi_t - p_1 \quad (98)$$

at highest single tooth contact:

$$\rho_1 \cos \phi_t = \rho_2 \quad (99)$$

$$\rho_2 = \sqrt{r_0^2 - (R \cos \phi_t)^2} - p \cos \phi_t \quad (100)$$

Where

- r_0 = outer radius for pinion (in)
- r = pitch radius for pinion (in)
- R_0 = outer radius for gear (in)
- r = pitch radius for gear (in)
- p = circular pitch $p = \pi/P_d$
- C = center distance (in)
- P_t = transverse pressure angle

Because the spiral bevel gear has a complicated tooth geometry which is difficult to deal with analytically, in order to calculate the two critical point curvatures, a Tregold's

approximation which reduces the spiral bevel gear problem to the helical gear is used here [9]. Thus we can use the helical gear formula to solve the spiral bevel gear problem. It uses the equivalent helical gears of the back cones of the bevel gears for tooth numbers greater than 8. This method is sufficiently accurate for practical purposes. The equivalent helical gear is calculated as [9]:

$$R_{vp} = \frac{r}{\cos \gamma_A} \quad R_{VG} = \frac{R}{\cos \gamma_B} \quad (101)$$

R_{vp} = pitch radius of equivalent helical pinion (in)

R_{VG} = pitch radius of equivalent helical gear (in)

r = pitch radius of bevel pinion at the large end (in)

R = pitch radius of bevel gear at the large end (in)

γ_A = pitch angle for pinion

γ_B = pitch angle for gear

Since bevel gears do not have any center distance dimension, the equations (1)-(4) can be modified as follows:

At lowest single contact point

$$\rho_1 = \sqrt{r_0^2 - (R_{vp} \cos \phi_t)^2} - p \cos \phi_t \quad (102)$$

$$\rho_2 = (R_{vp} + R_{VG}) \cos \phi_t \quad (103)$$

At highest single contact point

$$\rho_1 = (R_{vp} + R_{vg}) \cos \phi_t - \rho_2 \quad (104)$$

$$\rho_2 = \sqrt{R_0^2 - (R_{vg} \cos \phi_t)^2} - p \cos \phi_t \quad (105)$$

where

$$r_0 = R_{vp} + 1.0/P_d \quad (106)$$

$$R_0 = R_{vg} + 1.0/P_d \quad (107)$$

r_0 = outer radius of equivalent helical pinion

R_0 = outer radius of equivalent helical gear

Now we can calculate Z_t at the two critical points. Then choose the smaller Z_t to calculate ΔT to get the critical flash temperature.

For aircraft spiral bevel gears, an allowable surface flash temperature is 493°F [17]. Here 400°F is imposed as an upper bound limit.

The other method to judge the risk of scoring is the scoring criterion number. The formula is:

$$\text{Calculate scoring number} = \left(\frac{W_t}{F_e}\right)^{3/4} \frac{n^{1/2}}{p} \frac{1}{P_d^4}$$

The AGMA standard has published the scoring criterion number table for various oils at various gear blank temperatures. If the calculated scoring number is above the value shown in the table, there is a risk of scoring [13].

Cold scoring occurs when the elastohydrodynamic oil film thickness is small

compared with the surface roughness and the lubricant does not have enough additives to prevent scoring on the contact tooth surfaces. A criterion used to determine the possibility of surface distress is the ratio of film thickness to composite surface roughness [13]:

$$\lambda = \frac{h_{\min}}{\sigma} \geq 1 \quad (108)$$

where $\sigma = \sqrt{\sigma_p^2 + \sigma_g^2}$

λ = film parameter

h_{\min} = minimum oil film thickness (in)

σ_p = surface roughness of pinion (rms)

σ_g = surface roughness of gear (rms)

There is a risk of cold scoring if λ is less than 1. Here the lower bound of 1 is used.

The calculation of h_{\min} is a quite complicated problem. It requires special data about the oil. A simple but approximate calculation for the minimum oil film thickness at the pitch line is used here

$$h_{\min} = \frac{44.6 r_e (\text{lubricant factor}) (\text{velocity factor})}{(\text{loading factor})} (\mu\text{in}) \quad (109)$$

where

r_e = effective radius of curvature at pitch diameter

$$r_e = \frac{c \sin \phi_n}{\cos^2 \psi} \frac{MG}{(MG + 1)^2} \quad (110)$$

Spiral Bevel gears do not have any contact distance, so use $c = (MG + 1)r$

$$r_e = \frac{r \sin \phi_n}{\cos^2 \psi} \cdot \frac{MG}{MG + 1} \quad (111)$$

r = pitch diameter at large end for pinion

ϕ_n = normal pressure angle

ψ = spiral angle

MG = gear ratio

Lubricant factor = $(\alpha E')^{0.54}$

α = lubricant pressure-viscosity coefficient in²/lb

E' = effective elastic modulus for a steel gear set

$$= \frac{\pi}{2} \frac{E}{(1 - \nu^2)} = 51.7 \times 10^6 \text{ psi} . \quad (112)$$

$$E = 3 \times 10^7 \text{ psi} \quad \nu = 0.3 \quad (113)$$

$$\text{Velocity factor} = \left(\frac{\mu_0 u}{E' r_e} \right)^{0.70}$$

μ_0 = lubricant viscosity at operating temperature (cp) and u = rolling velocity at the pitch line

$$u = \frac{\pi n_p d \sin \phi_t}{60} \text{ in / second} \quad (114)$$

$$\mu_0 = \mu \cdot e \left[\beta + \left(\frac{1}{T + 460} - \frac{1}{T_0 + 460} \right) \right]$$

- μ = viscosity at temperature T_0
- β = lube, temp-viscosity coefficient at lube ambient temperature (deg. R)
- T_0 = tooth bulk temperature
- T = temperature (deg. F)
- d = pinion pitch diameter at large end (in)
- ϕ_t = transverse pressure angle

$$\text{Loading factor} = (W_t/FE'r_e)^{0.13}$$

W_t = tangential load (Lb)

F = face width (in)

Face Contact Ratio

In order to insure a quiet, smooth, reliable gear mesh, the face contact ratio must be considered. The face contact ratio for a given spiral bevel gear is the ratio of face advance to the circular pitch. It must be greater than a minimum number. The value 1.25 is commonly used for spiral bevel gear.

Involute Intereference

Involute interference occurs when the addendum circle of one gear crosses the line of action past its point of tangency with the base circle on its mating gear. That is, its contact occurs below the base circle of the pinion on the non-involute portion. This phenomena also is called "undercut" and this weakens the gear. There are many ways to avoid undercut. The use of minimum pinion teeth to eliminate interference is imposed here.

The lower bound of teeth number for pinion is 12 for spiral bevel gears, when the pressure angle is 20° . On the other side, in order to avoid undercut with low numbers of teeth and balance the strength of gear and pinion teeth, there is a limit for gear and pinion teeth:

$$N_p + N_G \geq 34 \quad (\text{for pressure angle equals } 20^\circ) \quad (115)$$

Ratio of Face Width to Cone Distance

The AGMA standard recommended the ratio of face width to cone distance is equal to $1/3$ or $P_d/10$, whichever is smaller.

5.1 The Spiral Bevel Gear Program

The spiral bevel gear analysis program is written in the same general format as the spur gear analysis program. That is, the main routine is a sub routine called ANALIZ which can be directly coupled with the COPES/ADS optimization program.

The analysis routines include ANALIZ, INPUT, OUTPUT, PITTING, BENDING, SCORING, CONTR, WEIGHT, FLSHT, FMTH, LFAFBG, and LIFEFG. These are all contained in a FORTRAN file called SPIRLB. Subroutine ANALIZ is the main analysis control routine which is called by COPES for optimization. This routine contains the GLOBBCM common block which transfers data between the analysis and optimization. Subroutine INPUT reads all analysis data and subroutine OUTPUT prints the analysis results.

5.2 Parameters Contained in the Global Common Block

In subroutine ANALIZ, the labeled common block, GLOBBCM, contains the information that is transferred between the analysis and optimization routines. The common block is as follows:

```
COMMON/GLOBBCM/NTA,NTB,FWAD,FWBD,PR,SIGMA,PSI,PHI,SC,ST,SCORN,  
FLASHT,LAMDA,FCON,MF,WEIGHT,INTF1,INTF2,LF,MG
```

These parameters are defined in the following table for convenient reference:

Fortran

Loc	Parameter	Name	Units	Definition
1	N_P	NTA		Number of teeth in pinion
2	N_G	NTB		Number of teeth in gear
3	F	FWAD	in.	Face width of pinion
4	F	FWBD	in.	Face width of gear
5	P_d	PR	1/in.	Diametral pitch
6		SIGMA	degrees	Shaft angle
7		PSI	degrees	Spiral angle
8		PHI	degrees	Pressure angle
9	S_c	SC	psi	Hertzian stress
10	S_t	ST	psi	Bending stress
11	SCON	SCON		Scoring number
12	T_f	FLASHT	deg. F	Flash temperature
13		LAMDA		Thickness/roughness ratio
14	FCON	FCON		Ratio of face width/cone dist.
15	M_F	MF		Face contact ratio
16	WEIGHT	WEIGHT	lmb	Gear set weight
17	INF1	INF1		No involute inter. lower bound
18	INF2	INF2		Sum of gear mesh
19	L_F	LF	10^6 rev.	Gear mesh life
20	M_G	MG		Gear ratio

Input Data Description

As with the spur gear design, the data file consists of two parts. The first is the COPES input data which defines the optimization problem and the second is the analysis data for the spiral bevel gear.

Spiral Bevel Gear Input Data

There are seven lines of data as defined below.

Line 1

GEMATA, GEMATB, LUBNA

- GEMATA - pinion material
- GEMATB - gear material name
- LUBNA - lubricant name

Line 2

RPMA, SC, ST, Y1ESA, Y1ESB, YMAD, YMBD

- RPMA - RPM of pinion
- SC - allowable contact stress (psi)
- ST - allowable bending stress (psi)
- Y1ESA - pinion material yield stress (psi)
- Y1ESB - gear material yield stress (psi)
- YMAD - pinion material Young's modulus (psi)
- YMBD - gear material Young's modulus (psi)

Line 3

NTA, MG, HP, HB, SRMS1, SRMS2, BETA, TEMPLUB, SPHEA, SPHEB

- NTA - number of teeth in the pinion
- MG - gear ratio
- HP - input horsepower
- HB - minimum Brinell hardness of the gear set
- SRMS1 - pinion rms surface roughness (micro-inches)
- SRMS2 - gear rms surface roughness (micro-inches)
- BETA - lube temp-viscosity coef. at lub ambient temp (deg. R)
- TEMPLUB - lube ambient temperature (deg. F)

- SPHEA - specific heat of the pinion
 SPHEB - specific heat of the gear

Line 4

ALPHA, V1SD, DENSA, DENSB, CONDTA, CONDTB

- ALPHA - lub pressure-velocity coefficient (in^2/lb)
 V1SD - lube viscosity at lube ambient temperature
 DENSA - pinion mass density (lbm/in^3)
 DENSB - gear mass density (lbm/in^3)
 CONDTA - pinion thermal conductivity
 CONDTB - gear thermal conductivity

Line 5

FWAD, FWBD, PR, SIGMA, PSI, PHI

- FWAD - pinion face width
 FWBD - gear face width
 PR - diametral pitch
 SIGMA - shaft angle
 PSI - spiral angle
 PHI - pressure angle

Line 6

CA, CS, CM, DF, CL, CH, CT, CR

- CA - overload factor
 CS - size factor
 CM - load distribution factor
 CF - surface condition factor
 CL - life factor

- CH - hardness ratio factor
- CT - temperature factor
- CR - safety factor

Line 7

KO, KM, KL, KT, KR, FRM, EPSA, EPSB

- KO - overall factor
- KM - load distribution factor
- KL - life factor
- KT - temperature factor
- KR - safety factor
- FRM - friction coefficient of material
- EPSA - Poisson's ratio for the pinion
- EPSB - Poisson's ratio for the gear

5.3 Design Examples

The typical spiral bevel gear optimization problem can now be stated as:

- | | |
|----------------|--|
| Maximize | Life |
| Subject to | (1) Bending |
| Constraints to | (2) Pitting |
| | (3) Scoring number |
| | (4) Flash temperature |
| | (5) Film parameter |
| | (6) Ratio of face width to cone distance |
| | (7) Face contact ratio |
| | (8) Total weight of pinion and gear |
| | (9) Involute interference |
| | (10) Sum of number for pinion and gear |

In the following example the initial design was assumed that a single reduction spiral bevel gear set is to be designed for a 450 horsepower input from pinion shaft, the RPM of the pinion is to be 15000 RPM.

The material AISI 9310 is chosen here. The gears are assumed to be made from case hardened alloy steel with ground tooth surfaces. Its hardness is 620 H_B. A constant pinion speed and gear ratio are maintained during the optimization.

Super-refined naphthenic mineral oil is used as the lubricant.

The initial values are described as follows:

Gear Data:

Number of teeth for pinion	31
Number of teeth for gear	46.5
Gear ratio	1.5
Shaft angle	90 degrees
Pressure angle	20 degrees
Spiral angle	35 degrees
Diametral pitch	6/in

Standard Operating Conditions

Pinion	1500 Rpm
Gear	1000 Rpm
Ambient temperature	100°F

Gear Material Data

Material	AISI 9310
Density	0.283 Lb/in ³
Young's modulus	30,000,000 psi
Poisson's ratio	0.3

Surface finish	.6 RMS
<u>Lubricant Data:</u>	
Materials	Super-refined, naphthenic, mineral oil
Temperature-viscosity coefficient	7100°K
Thermal conductivity at 100°F	5.84 cp (centipoint)
Specific heat	956
Pressure viscosity coefficient	0.00013 in ² /Lb
Lub viscosity at ambient temperature	64.7 cp

Here two examples are presented. Both examples have the same design variables, constraints and objective function. The only difference is in the bounds on the gear weight, and the initial values of the design variables. Also, example 2 is for a different gear ratio.

The number of pinion teeth, face width for (same face width for gear) and diametral pitch are design variables for both examples.

The objective function is to maximize the gear mesh life.

Ten sets of constraints, which define the design space, are used in both examples.

Their lower and upper bounds are as follows:

1. $0 \leq \text{Bending stress} \leq 240000 \text{ Lb/in}^2$.
2. $0 \leq \text{Pitting stress} \leq 180000 \text{ Lb/in}^2$.
3. $0 \leq \text{Scoring number} \leq 17000$.
4. $0 \leq \text{Flash temperature} \leq 400$.
5. $1 \leq \text{Film parameter} \leq 10^6$.
6. $0 \leq \text{Ratio of face width to cone distance} \leq 10$.
7. $1.25 \leq \text{Face contact ratio} \leq 10$.
8. $16 \leq \text{Total weight} \leq 17.30$ for example 1.
 $13 \leq \text{Total weight} \leq 13.27$ for example 2.
9. $12 \leq \text{Involute interference} \leq 50$.
10. $40 \leq \text{Sum of number pinion and gear teeth} \leq 150$.

The optimization results for example 1 are listed in Table 1, where the initial number of pinion teeth is 31. The gear ratio is 1.5 so the number of gear teeth is 46.5. The initial value for face width is 2.5 in, the initial diametral pitch is 6/in. In Tables 1 and 2, the parameters ISTRAT, IOPT and IONED refer to the strategy, optimizer and one-dimensional search options in the ADS program [5].

The initial design is an infeasible design. The upper bound of ratio of face width to cone distance is violated. The initial value for gear mesh life is 12958×10^6 cycles. After optimization, the optimizer brought the initial infeasible design to a feasible design. Here four different combinations of strategies have been used on this example and none of the constraints were violated. The gear mesh life is increased. Strategy 8 (Sequential Quadratic Programming) failed to produce an optimum design.

In example 2, different initial values of design variables were used. The number of the pinion teeth is 18, and the gear ratio is 3.5. The optimization results for example 2 are shown in Table 2. It is seen that the initial design is also infeasible. Two constraints are violated, one is the upper bound of flash temperature, the other is the upper bound on the ratio of the face width to cone distance. The optimizer brought the initial infeasible design to a feasible optimum design. At the optimum, none of the constraints were violated. The life was reduced from its initial infeasible value, but is optimum for the constraints that were imposed. Strategy 8 again failed to produce the optimum, although it came close.

Table 1
EXAMPLE 1

ISTRAT		0	6	8	6
IOPT		5	5	5	4
IONED		7	7	7	5
IPRINT		3050	3500	3500	3500
	INITIAL			OPTIMUM	
N_p	31	16	16	22.37	16
N_G	46.5	24	24	33.55	24
FW	2.5	3.131	3.15	2.331	3.146
PR	6	3.17	3.18	4.29	3.18
MG	1.5	1.5	1.5	1.5	1.5
Weight	17.25	17.30	17.22	17.225	17.25
Life	12958	20695	20562	13547	20501
Active	0	3	1	0	3
Violated	1	0	0	0	0

Table 2
EXAMPLE 2

ISTRAT	0	6	8	6
IOPT	5	5	5	4
IONED	7	7	7	5
IPRINT	3050	3500	3500	3500

	INITIAL		OPTIMUM		
N_p	18	12	12	12	12
N_G		42	42	42	42
FW	2.5	2.504	2.499	2.501	2.501
PR	6	4	4	4	4
MG	3.5	3.5	3.5	3.5	3.5
Weight	13.24	13.26	13.209	13.239	13.259
Life	29658	26908	26733	25668	26847
Active	0	3	3	3	3
Violated	2	0	0	0	0

Summary

From the results of the examples that are presented here, it can be seen that the life can be increased by decreasing the diametral pitch without increasing the weight. Also the face width is another significant factor for life. The optimizer changes the design variables until an acceptable design can be gained. In these two examples, the optimizer brought the initial infeasible design to feasible (even though sometimes the life is reduced). In example 1, after optimization the final mesh life is roughly 59% more than the initial design. In example 2 after optimization the final mesh life is roughly 9% less than the initial design, but it is feasible design.

Further Work

This program is only used for a standard bevel gear set with shaft angle 90° , pressure angle 20° and spiral angle 35° because of lack of some information. It may be expected that the spiral angle also is a significant factor for the mesh life. Thus, if enough information is available to modify the program and include this effect, the use of this program will be broadened.

6.0 SUMMARY

Design of precision gears has been addressed as a numerical optimization task. The principal objective here has been to investigate how optimization methods may be applied to this design problem and to demonstrate the resulting technology. To achieve this, the development of software that demonstrates the theoretical concepts is necessary. This is consistent with the overall goal of research, which is to produce a usable tool for engineering design.

Two gear design programs have been developed, one for spur gear design and one for spiral bevel gear design. These codes have been demonstrated with test cases to demonstrate their applicability to typical gear design problems. The key to successful

design optimization is that a wide variety of constraints must be considered. For example, if a gear is designed for minimum noise without regard to bending or Hertzian stress constraints, the resulting design will be of little practical use, since it will soon fail due to insufficient strength. Thus, an essential part of this effort has been to consider many constraints, something that is natural for the numerical optimization approach to design.

A basic gear design capability has been developed here. This effort has dealt only with the gear itself, as opposed to the overall speed reduction system which includes shafting, housing, powerplant, etc. Also, the analysis tools used here are relatively basic. Continuing research is considering more detail in the analysis. This includes more sophisticated models for noise generation as well as more detailed models of the gear teeth themselves. In the later case, research is being undertaken to model the gear teeth using finite element methods. An example of this effort is to design gear teeth which have an involute profile under the deformed state, as opposed to the design where the unloaded gear is an involute shape.

The use of numerical optimization has been shown to significantly improve the life of gears, reduce noise, and otherwise enhance the design process. Most importantly, this technology provides the ability to investigate the tradeoffs between the competing constraints in a rational way.

7. REFERENCES

1. Savage, M, J.J. Coy and D.P. Townsend: Optimal Tooth Numbers for Compact Standard Spur Gear Sets, ASME Journal of Mechanical Design, Vol. 104, Oct. 1982.
2. Vanderplaats, G.N.: Numerical Optimization Techniques for Engineering Design: With Applications, McGraw-Hill, 1984.
3. Vanderplaats, G.N., "COPES/ADS - A FORTRAN Program for Engineering Synthesis Using the ADS Optimization Program, Version 2.0, " Engineering Design Optimization, Inc., Santa Barbara, CA 1988.
4. Vanderplaats, G.N. and Sugimoto, H., "A General-Purpose Optimization Program for Engineering Design," International Journal of Computers and Structures, Vol. 24, No. 1, 1986.
5. Vanderplaats, G.N., "ADS - A FORTRAN Program for Automated Design Synthesis, Version 3.00," Engineering Design Optimization, Inc., Santa Barbara, CA, 1988.
6. Coy, J.J., D.P. Townsend, and E.V. Zaretsky: An Update on the Life Analysis of Spur Gears, NASA, CP-2210,1982, pp. 421-434.
7. Townsend, D.P., J.J. Coy, and E.V. Zaretsky: Experimental and Analytical Load-Life Relation for AISI 9310 Steel Spur Gears, NASA TM-X-73590, 1977.
8. Coy, J.J., D.P. Townsend, and E.V. Zaretsky: Analysis of Dynamic Capacity of Low-Contact-Ratio Spur Gears Using Lundberg-Palmgren Theory, NASA TND-8029, 1975.
9. Buckingham, E.: Analytical Mechanics of Gears, McGraw-Hill, New York, 1949.
10. Dudley, D.W.: Gear Handbook, McGraw-Hill, 1962.
11. Shigley, J.E., and L.D. Mitchell: Mechanical Engineering Design, McGraw-Hill, 1983.
12. Mitchiner, R.G. and H.H. Mabie: The Determination of the Lewis Form Factor and the AGMA Geometry Factor J for External Spur Gar Teeth, ASME Journal of Mechanical Design, Vol. 104, Jan. 1982, pp. 148-158.
13. Lynwander, Peter: Gear Drive Systems, Marcel Dekker, Inc. 1983.
14. Dudley, D.W.: Handbook of Practical Gear Design, McGraw-Hill, 1984.

- 15 Dowson, D. and G.R. Higginson: *Elasto-Hydrodynamic Lubrication*, Pergamon Press, 1977.
16. Blok, H., *Surface Temperatures Under Extreme Pressure Conditions*, 2nd Work, Petroleum Congress, Paris, September 1937.
17. Coleman, W., *Bevel and Hypoid Gear Surface Durability: Pitting and Scuffing*, Proc. Inst. Mech. Engrs. 1967-68, Vol. 182 Pt3A.

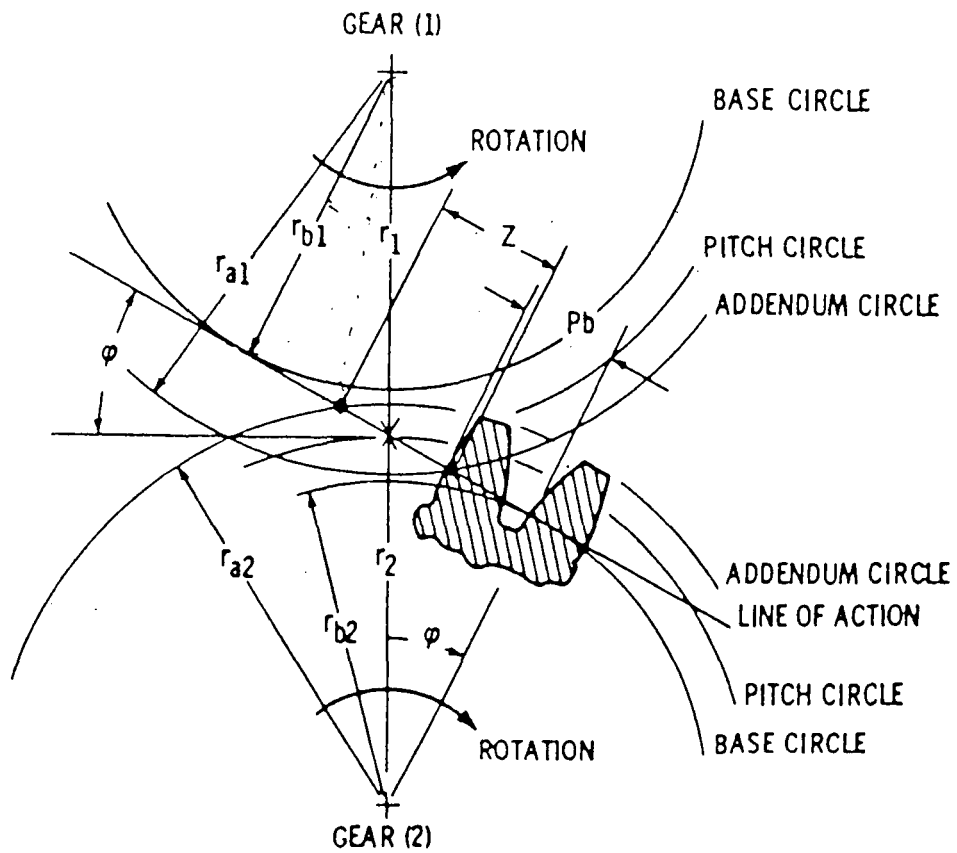

FIG. 1 - Spur Gear Geometry

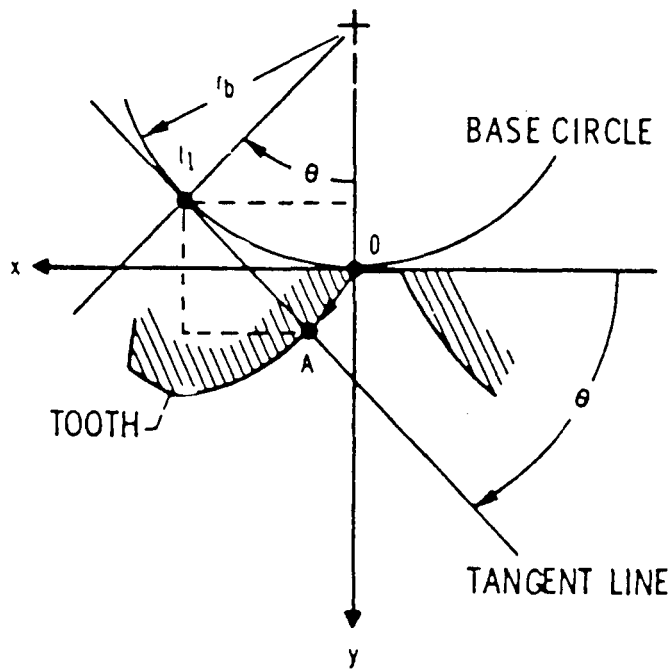

FIG. 2 - Geometric Details

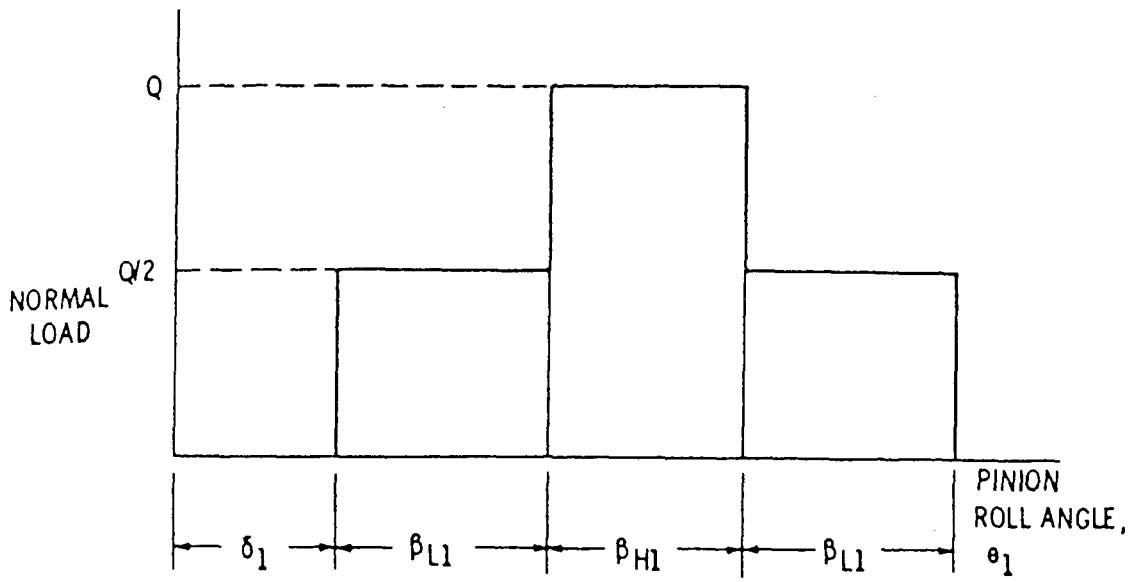

FIG. 3 - Loading

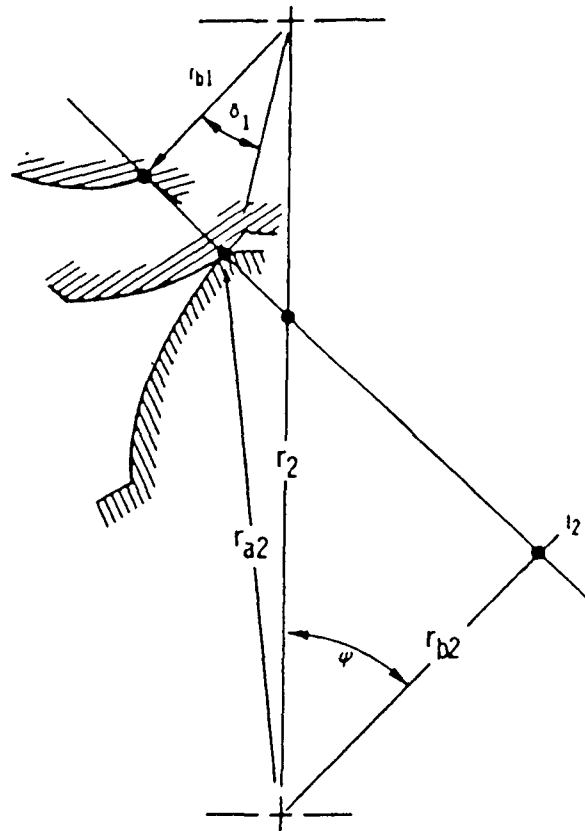

FIG. 4 - Geometric Details

ORIGINAL PAGE IS
OF POOR QUALITY

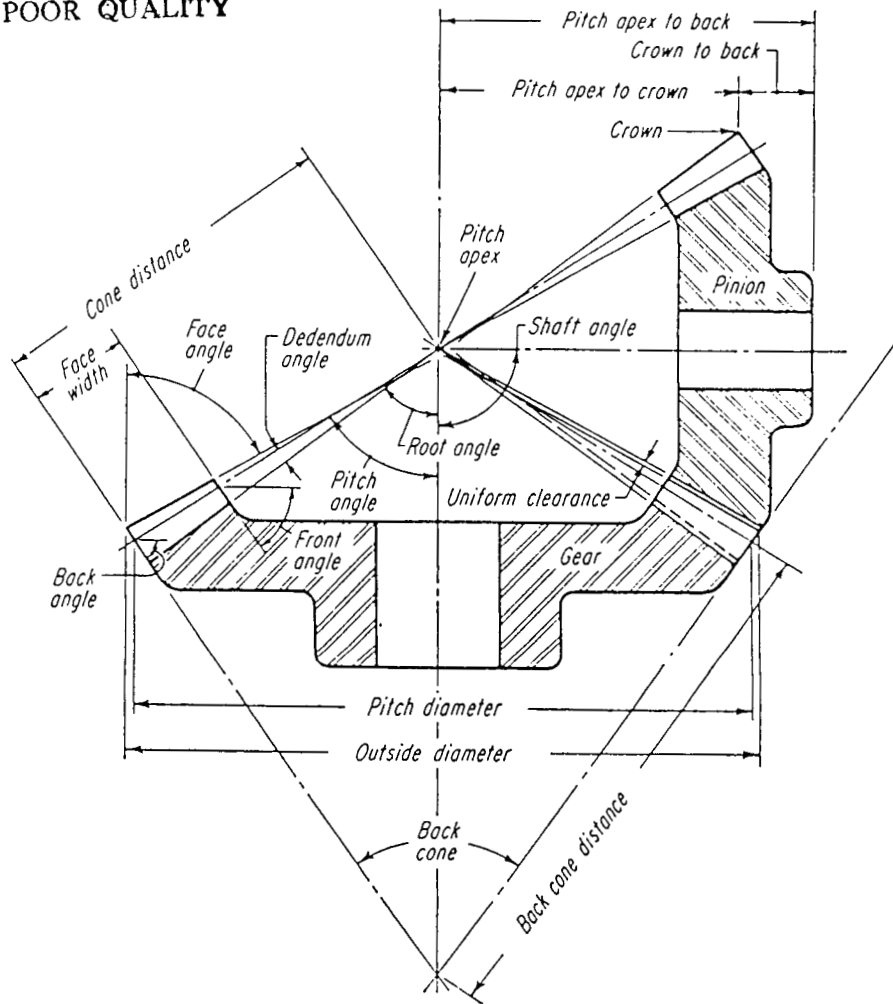

FIG. 5 - Spiral Bevel Gear Geometry

1. Report No. NASA CR-4201		2. Government Accession No.		3. Recipient's Catalog No.	
4. Title and Subtitle Gear Optimization			5. Report Date December 1988		
			6. Performing Organization Code		
7. Author(s) G.N. Vanderplaats, Xiang Chen, and Ning-tian Zhang			8. Performing Organization Report No. None (E-4459)		
			10. Work Unit No. 505-63-51		
9. Performing Organization Name and Address Department of Mechanical Engineering University of California Santa Barbara, California 93106			11. Contract or Grant No. NAG3-683		
			13. Type of Report and Period Covered Contractor Report Final		
12. Sponsoring Agency Name and Address National Aeronautics and Space Administration Lewis Research Center Cleveland, Ohio 44135-3191			14. Sponsoring Agency Code		
			15. Supplementary Notes Project Manager, Harold H. Coe, Propulsion Systems Division, NASA Lewis Research Center.		
16. Abstract <p>The purpose of this study was to investigate the use of formal numerical optimization methods for the design of gears. To achieve this, computer codes were developed for the analysis of spur gears and spiral bevel gears. These codes calculate the life, dynamic load, bending strength, surface durability, gear weight and size, and various geometric parameters. It is necessary to calculate all such important responses because they all represent competing requirements in the design process. The codes developed here were written in subroutine form and coupled to the COPES/ADS general purpose optimization program. This code allows the user to define the optimization problem at the time of program execution. Typical design variables include face width, number of teeth and diametral pitch. The user is free to choose any calculated response as the design objective to minimize or maximize and may impose lower and upper bounds on any calculated responses. Typical examples include life maximization with limits on dynamic load, stress, weight, etc. or minimization of weight subject to limits on life, dynamic load, etc. The research codes were written in modular form for easy expansion and so that they could be combined to create a multiple reduction optimization capability in the future.</p>					
17. Key Words (Suggested by Author(s)) Spur gear Spiral bevel gear Fatigue life Weight			18. Distribution Statement Unclassified - Unlimited Subject Category 37		
19. Security Classif. (of this report) Unclassified		20. Security Classif. (of this page) Unclassified		21. No of pages 68	22. Price* A04