

NASA
Technical Memorandum 101431

AVSCOM
Technical Report 87-C-38

Effect of Advanced Component Technology on Helicopter Transmissions

(NASA-TM-101431) EFFECT OF ADVANCED
COMPONENT TECHNOLOGY ON HELICOPTER
TRANSMISSIONS (NASA) 18 p

CSSL 01C

N89-13794

Unclas
G3/37 0183235

David G. Lewicki
Propulsion Directorate
U.S. Army Aviation Research and Technology Activity—AVSCOM
Lewis Research Center
Cleveland, Ohio

and

Dennis P. Townsend
Lewis Research Center
Cleveland, Ohio

Prepared for the
International Power Transmission and Gearing Conference
sponsored by the American Society of Mechanical Engineers
Chicago, Illinois, April 25-27, 1989

NASA



EFFECT OF ADVANCED COMPONENT TECHNOLOGY ON HELICOPTER TRANSMISSIONS

David G. Lewicki
Propulsion Directorate
U.S. Army Aviation Research and Technology Activity - AVSCOM
Lewis Research Center
Cleveland, Ohio 44135

and

Dennis P. Townsend
National Aeronautics and Space Administration
Lewis Research Center
Cleveland, Ohio 44135

ABSTRACT

Experimental tests were performed on the NASA/Bell Helicopter Textron (BHT) 500-hp advanced technology transmission (ATT) at the NASA Lewis Research Center. The ATT was a retrofit of the OH-58C helicopter 236-kW (317-hp) main rotor transmission, upgraded to 373 kW (500 hp), with a design goal of retaining long life with a minimum increase in cost, weight, and size. Vibration, strain, efficiency, deflection, and temperature experiments were performed and the results were compared to previous experiments on the OH-58A, OH-58C, and UH-60A transmissions. The high-contact-ratio gears and the cantilever-mounted, flexible ring gear of the ATT reduced vibration compared to that of the OH-58C. The ATT flexible ring gear improved planetary load sharing compared to that of the rigid ring gear of the UH-60A transmission. The ATT mechanical efficiency was lower than that of the OH-58A transmission, probably due to the high-contact-ratio planetary gears.

INTRODUCTION

Over the past 30 years the helicopter has evolved into a valuable air vehicle for both military and commercial use. The design and performance requirements of helicopters are continuously becoming more demanding with specific goals of increasing life, reliability, and maintainability while decreasing weight and noise. Helicopter drive trains and in particular, transmissions, require advances in state-of-the-art technology in order to meet these requirements.

In most cases the technology to meet these challenges has been placed by military interests (1). Currently, the U.S. Army has a wide spectrum of helicopters in its inventory ranging from light observation to medium-lift cargo (such as the OH-58, UH-1, CH-47, UH-60, and AH-64). Much of the fleet became operational in the 1960's and have continued in service through several versions (A, B, C, D series) with each version placing more demands on the drive train. Thus, advances in current drive train designs as well as innovative new concepts play an important role in meeting the next-generation rotorcraft needs.

In an effort to advance helicopter transmission technology NASA Lewis Research Center awarded a contract to Bell Helicopter Textron (BHT) for the design, development, and manufacture of a 373-kW (500-hp) demonstrator transmission. The design emphasis of the NASA/BHT advanced technology transmission (ATT) was to develop a 373-kW (500-hp) version of the OH-58C 236-kW (317-hp) main rotor transmission that would have long, quiet life at a minimum increase in cost, weight, and space. This was accomplished by implementing advanced technologies that have been developed during the last decade and making improvements dictated by field experience (2).

The objective of the present study is to report on the experimental testing performed on the NASA/BHT 500-hp ATT and compare the results to previous experiments on the OH-58A, OH-58C, and UH-60A transmissions. The tests were conducted in the NASA Lewis 500-hp helicopter transmission test stand, covering a range of torque and speed conditions. Vibration and efficiency experiments were performed on the ATT and compared to the OH-58A and OH-58C. Deflection and temperature experiments were performed on the ATT and compared to the OH-58A. Ring gear strain experiments were performed on the ATT and compared to the UH-60A.

APPARATUS

OH-58 Main Rotor Helicopter Transmissions

The OH-58 is a single-engine, land-based light observation helicopter. The helicopter serves both military (OH-58 Kiowa) and commercial (Bell Model 206 Jet Ranger) needs. The OH-58A main rotor transmission (Fig. 1) is rated for use at an engine output of 201-kW (270-hp) continuous power at 6180 rpm and 236 kW (317 hp) for 5 min at takeoff. The transmission is a two-stage reduction gearbox. For the first stage the input shaft drives a 19-tooth spiral-bevel pinion gear, which meshes with a 71-tooth gear. The bevel pinion shaft is mounted on triplex ball bearings and one roller bearing. The bevel gear shaft is mounted overhung on duplex ball bearings and one roller bearing.

A planetary mesh provides the second reduction stage. The bevel gear shaft is splined to a sun gear shaft. The 27-tooth sun gear drives three 35-tooth planet gears. The planet gears mesh with a 99-tooth fixed ring gear, which is splined to the top case. The planet gears are mounted on double-row spherical roller bearings and the bearings are attached to the planet carrier. Power is taken out through the planet carrier, which is splined to the mast output shaft. The output shaft is supported by a ball bearing and a roller bearing. The overall reduction ratio of the main power train is 17.44:1.

The 71-tooth bevel gear also drives a 27-tooth accessory gear. The accessory gear runs an oil pump, and lubrication is supplied through jets located in the top and bottom cases.

The OH-58C main rotor transmission is identical to the OH-58A with the exception of the planetary arrangement. The OH-58C has four planets, compared to three in the OH-58A. The planet bearings in the OH-58C are double row cylindrical roller bearings, compared to spherical roller bearings in the OH-58A. The OH-58C also has a different planet carrier design, that being a two-piece carrier straddle mounting the planet gears.

500-hp Advanced Technology Transmission

The design goal of the NASA/Bell Helicopter Textron (BHT) 500-hp advanced technology transmission (ATT) was to upgrade the OH-58C 236-kW (317-hp) version to 373 kW (500 hp) while retaining long life and low noise with a minimum increase in cost, weight, and size. This was accomplished by implementing advanced technology developed during the last decade and improvements dictated by field experience (2).

The ATT (Fig. 2) has the same basic configuration, the same number of teeth on the gears, and the same speed reduction ratio as the OH-58C transmission. The advanced technology components, concepts, and improvements incorporated in the ATT are:

- (1) High-contact-ratio planetary spur gears intended to enable higher torques to be transmitted and at the same time reduce noise and increase gear life.
- (2) A cantilever-mounted planetary ring gear intended to provide a flexible mount for a more uniform load distribution among planets, isolation of the meshing teeth from the housing for noise reduction, and reduced debris generated due to the elimination of a working ring gear spline.
- (3) An oil transfer mechanism designed in the planet carrier for improved lubrication to the planetary gear meshes and the sun gear spline.
- (4) A straddle-mounted bevel gear intended to enable higher torques to be transmitted without destroying the tooth contact patterns.
- (5) An improved sun gear spline design (crown hobbled and hardened) running in a bath of flowthrough oil (provided by the planet carrier) to prevent excessive wearing.
- (6) Cleaner, stronger spiral-bevel gear steel (VIM-VAR 9310), vacuum carburized and shot peened, along with cleaner bearing steel (VIM-VAR M-50) intended to compensate for the increase in power transfer capability of the ATT with no decrease in gear or bearing lives.

The final size and weight of the ATT are 3.81 cm (1.50 in) taller and 6.0 kg (13.2 lb) heavier than the OH-58C (14 percent and 11 percent, respectively) for a 58-percent increase of power from 236 kW (317 hp) to 373 kW (500 hp). This summarizes to a decrease in weight-to-power ratio from 0.37 lb/hp for the OH-58C to 0.26 lb/hp for the ATT.

NASA 500-hp Helicopter Transmission Test Stand

The ATT was tested in the NASA Lewis 500-hp helicopter transmission test stand (Fig. 3). The test stand operates on the four-square or torque-regenerative principle. Mechanical power is recirculated through a closed loop of gears and shafting, one of which is the test transmission. In the test stand the output of the test transmission is attached to the bevel gearbox. The output shaft of the bevel gearbox passes through a hollow shaft in the closing-end gearbox and is connected to the differential gearbox. The output of the differential is attached to the hollow shaft in the closing-end gearbox. The output of the closing-end gearbox is connected to the input of the test transmission, thereby closing the loop.

A 149-kW (200-hp) variable-speed direct-current (dc) motor powers the test stand and controls the speed. The motor output is attached to the closing-end gearbox. Only losses due to friction are replenished by the motor since power is recirculated around the loop.

An 11-kW (15-hp) dc motor provides the torque in the closed loop. The motor drives a magnetic particle clutch. The clutch output does not turn but exerts a torque through a speed reducer gearbox and a chain drive to a large sprocket on the differential gearbox. The torque on the sprocket puts a torque in the closed loop. The magnitude of torque in the loop is adjusted by changing the electric field strength of the magnetic particle clutch.

The test transmission input and output shafts are equipped with speed sensors, torque meters, and slip rings. Test transmission lubrication is supplied by an internal oil pump. The transmission oil can be cooled by a flight hardware air-oil cooler mounted on the transmission (with forced air provided to the cooler) or by an external oil-water heat exchanger. An external oil-pumping system located in the basement below the test stand is also available for the test transmission.

The 149-kW (200-hp) motor is equipped with a speed sensor and a torque meter. The magnetic particle clutch is equipped with speed sensors on the input and output shafts and with thermocouples. A facility oil-pumping and cooling system lubricates the differential gearbox, the closing-end gearbox, and the bevel gearbox. The facility gearboxes are also equipped with accelerometers, thermocouples, and chip detectors for health and condition monitoring.

Instrumentation and Testing Procedure

First, the ATT was installed in the 500-hp test stand with a minimum amount of instrumentation. The transmission was run at a variety of speed and torque conditions as recommended by BHT as part of a break-in procedure. The speed and torque were gradually increased until full power was achieved. Upon completion of the break-in tests, the ATT was disassembled, inspected, instrumented, and reinstalled in the test stand. Vibration, strain, efficiency, deflection, and temperature experiments were then performed on the ATT. The experiments were all run independently, except for the efficiency and temperature tests, which were run at the same time.

The instrumentation, testing procedure, and data reduction of the ATT vibration experiments were patterned after the OH-58A vibration tests reported in Ref. 3. Seven piezoelectric accelerometers were mounted on the transmission housings (Fig. 4). The accelerometers were placed to cover a variety of locations and all three measurement directions: vertical,

longitudinal, and transverse. Each accelerometer produced a charge output proportional to acceleration. The outputs were fed to charge amplifiers that produced alternating-current (ac) voltages. The ac signals, which represented actual acceleration as a function of time, were recorded on magnetic tape for later processing.

Ring gear strain experiments were performed on the ATT to investigate load distribution in the planetary system. Strain gages were mounted on the back of the ATT cantilever-mounted (flexible) ring gear (Fig. 5(a)). The gages measured strain in the tangential direction on the ring gear indicating hoop stress levels. Strain gage conditioners provided the bridge completion, excitation, amplification, and shunt calibration. The conditioner output voltage represented strain as a function of time and was recorded on magnetic tape for later processing. Strain experiments were not available for the OH-58 spline-mounted (rigid) ring gear to compare with the ATT. Results were obtained, however, from UH-60A (Blackhawk) helicopter transmission experiments. These ring gear strain tests were performed in the NASA Lewis 3000-hp helicopter transmission test stand (4). Strain gages were installed on the back of the UH-60A rigid-mounted ring gear in a similar fashion as those on the ATT (Fig. 5(b)). A brief description of the UH-60A transmission and the 3000-hp test stand is given in the Appendix.

The ATT efficiency experiments were performed in the same manner as the OH-58A tests of Ref. 5. The test transmission and an oil-water heat exchanger (used to cool the transmission oil and maintain it at a constant temperature) were thermally insulated to provide an adiabatic enclosure. Provisions were setup to collect the water that flowed through the oil-water heat exchanger. The weight of the accumulated water and the difference in the heat exchanger water-outlet and water-inlet temperatures were measured. From these, the heat generation due to mechanical power losses of the transmission was calculated. Transmission efficiency was determined by subtracting the power losses from the measured input power, then dividing by the input power. The lubricant used for the ATT efficiency tests was that labeled "lubricant code K" in Ref. 5. Lubricant K was a synthetic gas turbine engine oil with a viscosity of 5 centistokes at 99 °C (210 °F).

Spiral-bevel gear deflection experiments were performed on the ATT to investigate the movement of the gear under load. A proximity probe was mounted close to the spiral-bevel gear near the mesh point to measure the gear displacement in the vertical direction under a variety of operating conditions (Fig. 6). The probe output signal was a voltage proportional to the clearance between the probe and the gear. The signal, which represented the clearance as a function of time, was recorded on magnetic tape for later processing. Iron-constantan thermocouples were placed at a variety of locations in the ATT to measure component temperatures (Fig. 6). Thermocouple signals on the rotating spiral-bevel pinion gear (thermocouples 1 and 2) and on the rotating planet bearing (thermocouple 10) were extracted through slip rings on the transmission input and output shafts, respectively.

The testing procedure for each experiment was as follows. First, all instrumentation checks on operation, calibration, and settings were made. Next, calibration signals were placed on tape (when appropriate). All safety interlocks and automatic shutdowns were tested. The transmission input speed was increased to approximately 3000 rpm to circulate oil throughout the transmission. The speed and torque were then adjusted

to the desired condition for testing. All transient signals were recorded on tape and later processed. For the efficiency tests the transmission was run at the desired condition until the component temperatures stabilized and the transmission reached steady-state. For each experiment the testing consisted of a matrix of speed and torque conditions. In general, the transmission input speed varied from 50 to 100 percent of its full-rated value and the transmission input torque varied from 25 to 100 percent of its full-rated value for each test.

RESULTS AND DISCUSSION

The ATT successfully operated at the full-rated design load (373 kW at 6180 rpm transmission input speed) during the break-in period and subsequent vibration, strain, efficiency, deflection, and temperature experiments. Thus, the major design goal of upgrading the OH-58C transmission to 373 kW (500 hp) was achieved. No endurance testing was performed on the ATT and therefore no comments can be addressed regarding transmission life. The performance of the ATT was evaluated by comparing the results of the vibration, strain, efficiency, deflection, and temperature experiments to previously conducted tests on the OH-58A, OH-58C, and UH-60A transmissions.

Vibration Tests

The ATT transient accelerometer outputs were retrieved from tape and fed to a spectrum analyzer. The spectrum analyzer converted the analog time traces to digital format and routed the signals to a computer for root-mean-square (rms) average calculations as described in Ref. 3. The ATT vibration experiments were compared to previous tests on the OH-58A (3) and OH-58C (not previously reported). The rms average accelerations for the accelerometers mounted on the ATT, OH-58A, and OH-58C housings ranged from 2 to 11 g's rms for a variety of torque conditions (Fig. 7). These results were from tests run at a transmission input speed of 6060 rpm for the OH-58A and OH-58C, and 6180 rpm for the ATT (6060 rpm is the maximum design speed of the transmission while 6180 rpm is the operational limit speed. Currently, the Army operates the OH-58 helicopters at 6180 rpm for the additional power capability). For five out of the seven accelerometers, the four-planet OH-58C had slightly less vibration (approximately 1 g rms) compared to the ATT at the same torque levels (accelerometers 1, 2, 4, 5, and 6; Figs. 7(a), 7(b), 7(d), 7(e), and 7(f), respectively). The OH-58C and the ATT had about the same levels of vibration at the same torque conditions for the remaining two accelerometers. The ATT had less vibration (2 to 3 g's rms) than the three-planet OH-58A at the same torque levels for five out of the seven accelerometers (accelerometers 2, 3, 4, 6, and 7; Figs. 7(b), 7(c), 7(d), 7(f), and 7(g), respectively). Based on the rms average calculations of the acceleration time traces, the general trend was that the OH-58C transmission had slightly less vibration than the ATT, and the ATT had less vibration than the OH-58A.

The vibration contributions of the spiral-bevel meshes and planetary meshes were determined for the ATT, OH-58A, and OH-58C. The contributions were calculated using power spectral density functions as described in Ref. 3. For each accelerometer the spiral-bevel mesh and planetary mesh vibration levels are shown in Fig. 8 for the OH-58A and OH-58C at 224 kW (300 hp) and 6060 rpm and the ATT at 233 kW (313 hp) and 6180 rpm. The planetary mesh vibration levels were lowest for the ATT and highest for the OH-58A for

nearly all the accelerometers (Fig. 8(a)). Thus, the number of planets (four compared to three), the planet mounting (straddle compared to cantilever), and the bearing type (cylindrical roller compared to spherical) significantly reduced planetary mesh vibration when comparing the OH-58C to the OH-58A at about full-rated power conditions. Also, the high-contact-ratio gears and the cantilever-mounted ring gear slightly reduced planetary mesh vibration when comparing the ATT and OH-58C.

For nearly all the accelerometers the spiral-bevel mesh vibration levels of the ATT and OH-58C were pretty much the same (Fig. 8(b)). Thus, the bevel gear mounting (straddle or overhung) had little effect on vibration for this speed and torque condition. For five out of the seven accelerometers the spiral-bevel mesh vibration levels of the OH-58A compared to the OH-58C were quite different (accelerometers 2 to 5). It is not known why these levels were different since the bevel systems are the same in both transmissions.

Planet Gear Load Sharing

The ATT ring gear strain gage signals were retrieved from tape and analyzed with an analog-to-digital converter and a computer. Typical traces of ring gear stresses as a function of planet-pass cycles are shown in Fig. 9(a) where the ATT operated at 373 kW (500 hp) and 6180 rpm transmission input speed. The ring gear strain gage signals from the UH-60A stress experiments (4) were retrieved from tape and analyzed in a similar manner as the ATT's. The results are shown in Fig. 9(b) for the UH-60A run at 2109 kW (2828 hp) and 258 rpm output rotor speed. These were the full-rated powers and speeds of both transmissions.

In Fig. 9, the peak stress values were connected by a dotted line for each transmission. Compare the trends of the values of the peak stresses for each of the two transmissions. The peaks correspond to the meshing of a planet gear with the ring gear at the location of the strain gage. The data were analyzed using 50-peak traces even though only 20 were plotted in the figure. For the ATT the mean peak value was 190.2 MPa (27 590 psi). The standard deviation was 5.7 MPa (830 psi), which corresponded to a 3-percent coefficient of variation (the coefficient of variation equals the standard deviation value divided by the mean value, times 100). In comparison, the UH-60A had a mean peak value of 58.0 MPa (8410 psi) and an 8.0-MPa (1160-psi) standard deviation. This gave a 14-percent coefficient of variation. In addition, the ATT's maximum peak value observed was 203.0 MPa (29 440 psi), approximately 7 percent above the mean value. The UH-60A's maximum peak value was 71.0 MPa (10 300 psi), 22 percent above the mean. Thus, the ATT had improved planetary load sharing compared to that of the UH-60A.

Planetary load sharing is a function of many items such as sun gear, planet gear, or ring gear stiffness, number of planets, type of mounting, etc. The ATT and UH-60A transmission are quite different in design, size, and power capabilities, and a direct comparison of the two is an oversimplification. The flexible ring gear of the ATT, however, had a significant role in the improved planetary load sharing compared to the rigid ring gear of the UH-60A. The flexible ring gear also has a significant role in decreasing potential overloading caused by uneven load distribution among the planets.

Note the shape of the stress-cycle curves for the two transmissions. The ATT results indicated the ring gear was loaded in a rather smooth manner while the UH-60A results implied the ring gear had impact loading characteristics. Also note that the magnitudes of the

ATT peak stresses were about three times higher than that of the UH-60A. This was expected due to the thin wall of the ATT ring gear, thus allowing greater deflections during loading. Follow-up analytical studies with the ring gears approximated as internally-pressurized, thin-walled cylinders were performed. These studies predicted that the ATT ring gear had a higher hoop stress value than the UH-60A. This was consistent with the results from the experimental strain tests.

Efficiency Tests

The ATT mechanical efficiencies ranged from 97.73 to 98.64 percent for a variety of torques and oil temperatures and 6180 rpm transmission input speed (Fig. 10). The ATT efficiency was relatively constant at higher torque levels and decreased at lower levels. At a given torque the efficiency increased at higher oil temperatures due to the decrease in oil viscosity and density. The ATT mechanical efficiencies were 98.51 and 98.62 percent at full-rated power conditions (373 kW (500 hp) at 6180 rpm transmission input speed) for oil-inlet temperatures of 82 °C (180 °F) and 99 °C (210 °F), respectively.

The lubricant used for the tests was that labeled code K in Ref. 5. Shown on Fig. 10 are the OH-58A efficiency values taken from Ref. 5 using lubricant K and at the OH-58A's full-rated power and speed. The ATT was approximately 0.25 percent less efficient than the OH-58A at the same torque levels. OH-58C efficiency results were available (not previously reported) run with lubricant code D of Ref. 5 at an oil-inlet temperature of 82 °C (180 °F). The OH-58C mechanical efficiency was 98.84 percent at full-rated power and speed, compared to 98.60 percent for the OH-58A at the same conditions and same lubricant type. Thus, the ATT was less efficient than the three-planet OH-58A and the OH-58A was less efficient than the four-planet OH-58C.

The cause of the ATT lower efficiency is believed to be the high-contact-ratio planetary gears. From the ATT design study, BHT reported a 0.30-percent decrease in efficiency in their Model 222 planetary system when high-contact-ratio gears were used (2). This level of decrease in efficiency was consistent with the 0.25-percent decrease in efficiency measured during the ATT experiments. Also, analytical studies on gear mesh power losses indicated high-contact-ratio gears are generally less efficient than standard gears (6). The reason is the higher gear tooth sliding velocities of the high-contact-ratio tooth. The major goal of the ATT design, however, was to improve the transmission power-to-weight ratio. One way this was accomplished was employing high-contact-ratio planetary gear teeth. The high-contact-ratio mesh enabled an increase in the mesh power capability for the same size gears. There was a slight reduction in efficiency believed to be due to the high-contact-ratio gears, but the transmission as a whole maintained its relatively high mechanical efficiency.

Spiral-Bevel Gear Deflection Tests

The ATT dynamic proximity probe output of the spiral-bevel gear was retrieved from tape and analyzed with an analog-to-digital converter and a computer. The output represented the clearance between the gear and the probe. The initial gear-probe clearance at zero speed and load was recorded and the probe outputs at various speed and load conditions were subtracted from the initial clearance to determine the deflections of the spiral-bevel gear near the location of the mesh.

The spiral-bevel gear deflections exhibited a linear relationship with respect to applied load for

torques in the range of 10 to 100 percent of full-rated. This linear relationship, however, had a no-load offset (i.e., the calculated deflection-load relationship predicted a deflection at zero torque. This indicated that there was excessive clearance in the spiral-bevel gear assembly. After a slight amount of load was applied on the gear, the clearance was removed and the gear exhibited the linear deflection-load relationship). Subtracting the no-load offset gave the linear relationship depicted in Fig. 11. Also shown in the figure are the spiral-bevel gear deflections of the OH-58A transmission from Ref. 7. The OH-58A deflection data also had their no-load offset subtracted out. Note that the ATT and OH-58A had about the same deflection-load relationship. This indicates that the spiral-bevel gear deflections in the vertical direction near the mesh point were not affected by the different bearing mounting conditions of the ATT (straddle mounted) and OH-58A (overhung mounted).

Further investigations of Fig. 11 revealed a deflection-torque slope of 0.54×10^{-6} m/N-m. Multiplying the deflection-torque slope by the bevel gear mean pitch radius of 3.05 cm and taking the reciprocal gave a stiffness value of 6.07×10^7 N/m (350 000 lb/in.). Calculating the axial bearing stiffness of a single ball bearing of the gear assembly using the methods of Harris (8) gave a value of 4.24×10^8 N/m (2 400 000 lb/in.). Since the calculated axial bearing stiffness value was much higher than the measured gear assembly value, the bevel gear deflection in the vertical direction near the mesh was not primarily caused by bearing deflections. The gear deflections were probably mostly due to gear body, gear shaft, or housing deflections. This offers an explanation why the deflections were not affected by the different bearing mounting of the ATT and OH-58A.

Component Temperature Tests

The ATT component temperatures were recorded during the efficiency experiments. Figure 12 depicts the temperature survey at 6180 rpm transmission input speed and three different torques. The transmission was enclosed with insulation and the results in the figure are for an oil-inlet temperature of 82 °C (180 °F). OH-58A component temperature data are also shown in the figure for a transmission input speed of 6060 rpm. The OH-58A data were taken from efficiency studies not previously published, with the transmission insulated and maintained at an 82 °C (180 °F) oil-inlet temperature.

The temperatures measured higher for the ATT compared to the OH-58A for nine out of the eleven components instrumented. This was expected because the ATT was operating at higher torque values than those of the OH-58A. The measured oil flow rates were about 23 l/min (6 gpm) for the ATT and about 19 l/min (5 gpm) for the OH-58A. The measured temperatures ranged from 78 °C (172 °F) to 116 °C (241 °F). The high-speed bevel pinion components had the highest temperatures (thermocouples 1 to 6). Thermocouples 4 to 6 were mounted near the bevel gear out-of-mesh location to measure oil temperature as it was flung from the gear mesh. An interesting observation was that the ATT fling-off temperature distribution along the gear face were reversed compared to those of the OH-58A (temperatures for thermocouples 4, 5, and 6 were in ascending order for the ATT and descending order for the OH-58A). The planet bearings (thermocouple 10) measured low temperatures for both the ATT and OH-58A.

SUMMARY OF RESULTS

Experimental tests were performed on the NASA/Bell Helicopter Textron (BHT) 500-hp advanced technology transmission (ATT) at the NASA Lewis Research Center. The ATT was a retrofit of the OH-58C helicopter 236-kW (317-hp) main rotor transmission, upgraded to 373 kW (500 hp), with a design goal of retaining long life with a minimum increase in cost, weight, and size. The tests were conducted in the NASA Lewis 500-hp helicopter transmission test stand, covering a range of torque and speed conditions. Vibration, strain, efficiency, deflection, and temperature experiments were performed and the results were compared to previous experiments on the OH-58A, OH-58C, and UH-60A transmissions. The following results were obtained:

1. The ATT successfully operated at the full-rated design load of 373 kW (500 hp) at 6180 rpm transmission input speed.

2. Based on the overall rms average acceleration values, the OH-58C transmission had slightly less vibration than the ATT, and the ATT had less vibration than the OH-58A transmission.

3. The ATT planetary mesh vibration levels were slightly lower compared to those of the OH-58C transmission. Thus, the high-contact-ratio gears and the cantilever-mounted, flexible ring gear reduced vibration. The OH-58A planetary mesh vibration levels were higher compared to those of the OH-58C transmission. Thus, increasing the number of planets and straddle mounting the planets reduced vibration.

4. The ATT flexible ring gear improved planetary load sharing compared to that of the rigid ring gear of the UH-60A transmission.

5. The ATT mechanical efficiency was lower than that of the OH-58A transmission, probably due to the high-contact-ratio planetary gears.

6. The spiral-bevel gear deflections in the vertical direction near the mesh point were not affected by the different bearing mounting conditions of the ATT (straddle mounted) compared to the OH-58A (overhung mounted).

7. In general, the component temperatures measured higher for the ATT compared to the OH-58A at full-rated powers of both transmissions, probably due to the higher torque values of the ATT.

REFERENCES

1. Weden, G.J., and Coy, J.J., 1985, "Summary of Drive Train Component Technology in Helicopters," Gears and Power Transmission Systems for Helicopters and Turboprops, AGARD CP-369, AGARD, Neuilly-Sur-Seine, France, pp. 2-1 to 2-17. (NASA TM-83726.)
2. Braddock, C.E., and Battles, R.A., 1983, "Design of an Advanced 500-hp Helicopter Transmission," Advanced Power Transmission Technology, G.K. Fisher, Ed., NASA CP-2210, pp. 123-139.
3. Lewicki, D.G., and Coy, J.J., 1987, "Vibration Characteristics of OH-58A Helicopter Main Rotor Transmission," NASA TP-2705 (AVSCOM TR-86-C-42).
4. Oswald, F.B., 1987, "Gear Tooth Stress Measurements on the UH-60A Helicopter Transmission," NASA TP-2698.

5. Coy, J.J., Mitchell, A.M., and Hamrock, B.J., 1984, "Transmission Efficiency Measurements and Correlations With Physical Characteristics of the Lubricant," *Gears and Power Transmission Systems for Helicopters and Turboprops*, AGARD CP-369, AGARD, Neuilly-Sur-Seine, France, pp. 20-1 to 20-15. (NASA TM-83740.)
6. Anderson, N.E., and Lowenthal, S H., 1986, "Efficiency of Nonstandard and High Contact Ratio Involute Spur Gears," *Journal of Mechanisms, Transmissions, and Automation in Design*, Vol. 108, No. 1, pp. 119-126.
7. Townsend, D.P., Coy, J.J., and Hatvani, B.R., 1976, "OH-58 Helicopter Transmission Failure Analysis," NASA TM X-71867.
8. Harris, T.A., 1984, *Rolling Bearing Analysis*, 2nd Edition, Wiley, New York.

transmission has a twin engine power rating of 2109 kW (2828 hp) at an output rotor speed of 258 rpm. The transmission is a three-stage reduction gearbox consisting of two input modules and one main module. For the first reduction stage the two input modules each contain a spiral-bevel gear mesh. The second and third reduction stage is contained in the main module and accomplished by a spiral-bevel mesh and five-planet planetary system. The overall reduction ratio is 81.042:1. A more complete description of the transmission is given in Ref. 4.

NASA 3000-hp Helicopter Transmission Test Stand

The UH-60A (Blackhawk) transmission was tested in the NASA Lewis 3000-hp helicopter transmission test stand. The test stand consists of three regenerative power-flow loops (two inputs to the UH-60A transmission simulating the twin engine inputs, and a tail rotor output), all recirculating through the main rotor output. Torque through each loop is controlled independently as well as test stand speed. The test stand also has the capability of applying forces to the transmission output shaft simulating flight lift, moment, and drag rotor loads. A more detailed description of the test stand is given in Ref. 4.

APPENDIX

UH-60A Main Rotor Transmission

The UH-60A (Blackhawk) is a double-engine, medium-lift cargo helicopter. The UH-60A main rotor

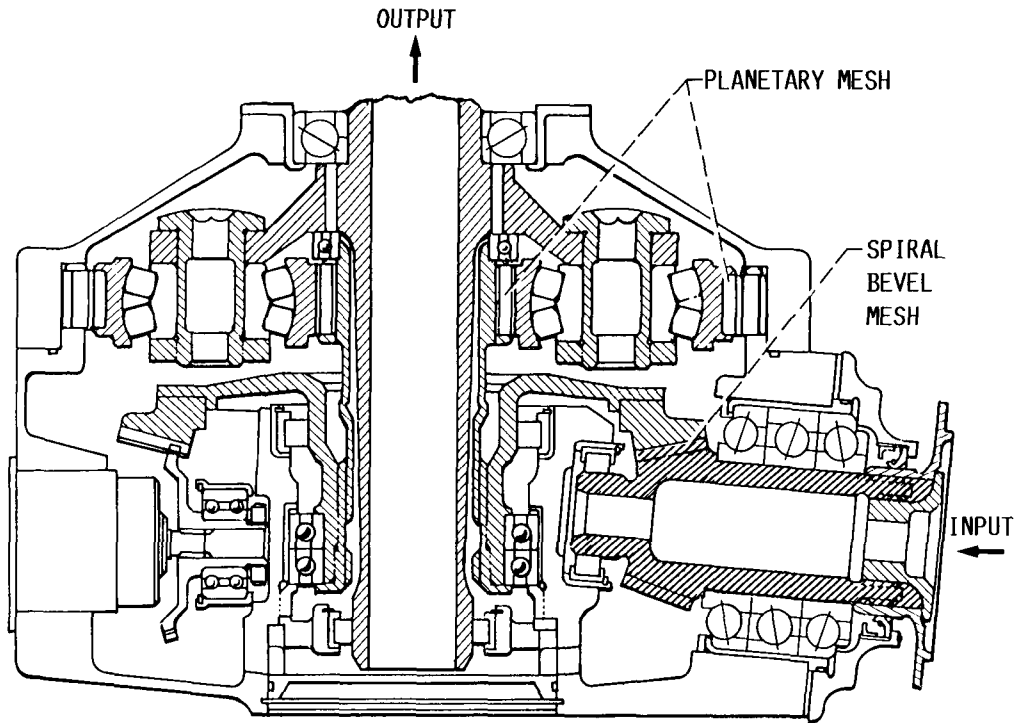

FIGURE 1. - OH-58A HELICOPTER MAIN ROTOR TRANSMISSION.

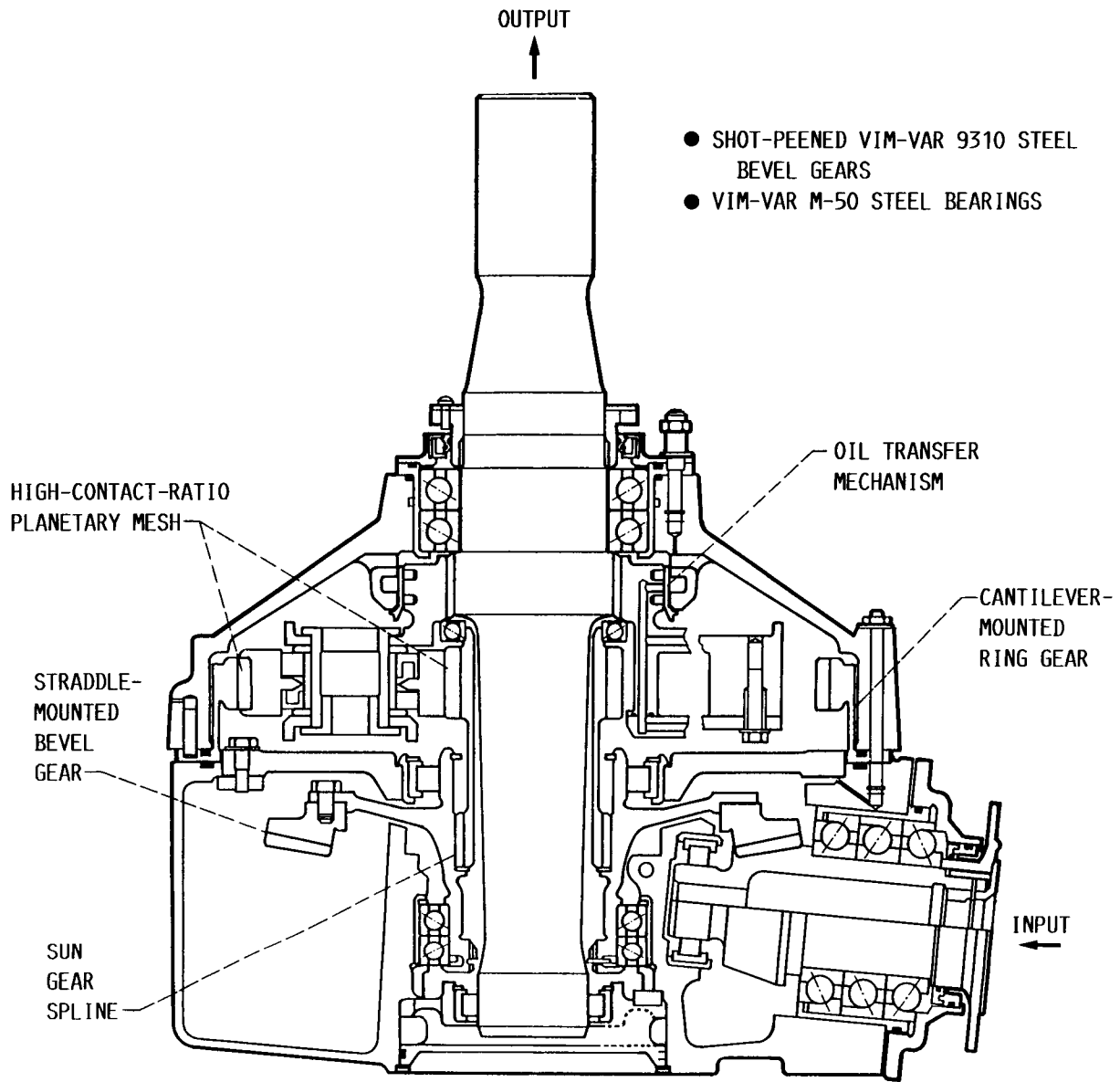

FIGURE 2. - NASA/BELL HELICOPTER TEXTRON 500-HP ADVANCED TECHNOLOGY TRANSMISSION.

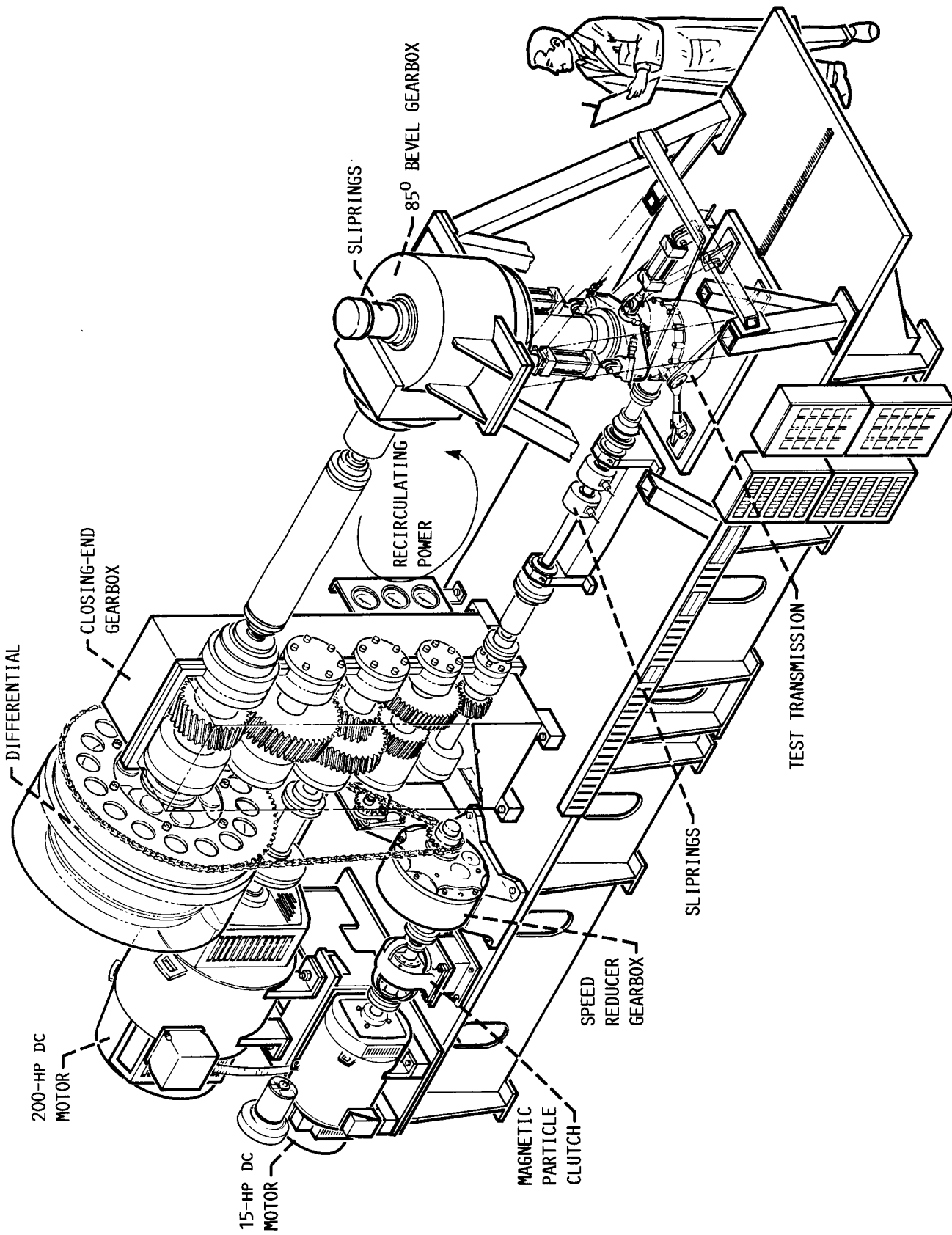

FIGURE 3. - NASA LEWIS 500-HP HELICOPTER TRANSMISSION TEST STAND.

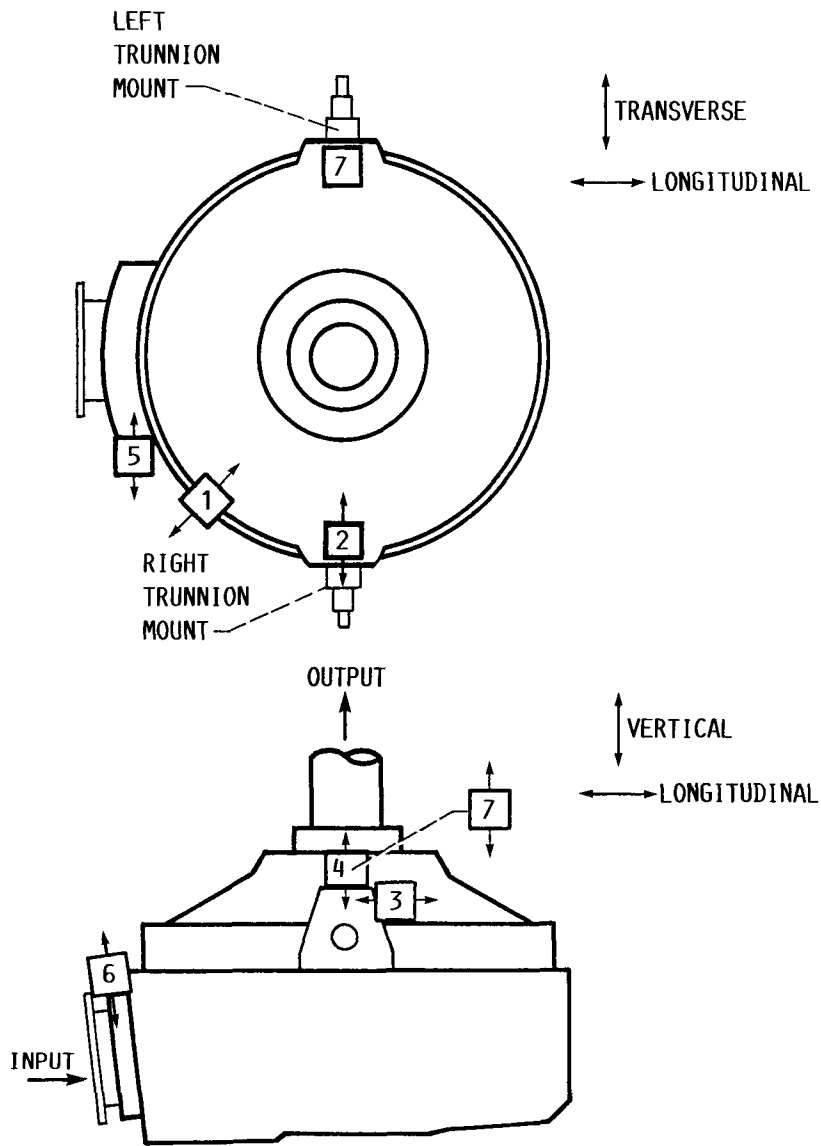
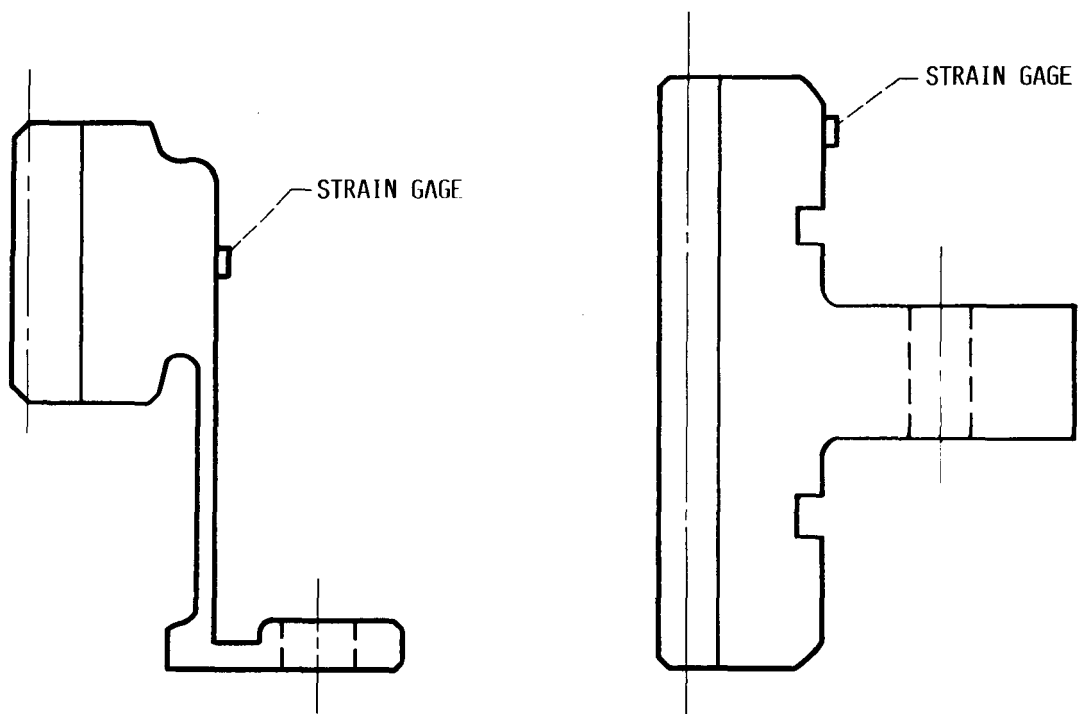

FIGURE 4. - ACCELEROMETER LOCATIONS ON OH-58A, OH-58C, AND ADVANCED TECHNOLOGY TRANSMISSION.



(a) FLEXIBLE RING GEAR, ADVANCED TECHNOLOGY TRANSMISSION.

(b) RIGID RING GEAR, UH-60A TRANSMISSION.

FIGURE 5. - STRAIN GAGE LOCATIONS ON ADVANCED TECHNOLOGY TRANSMISSION AND UH-60A TRANSMISSION RING GEARS.

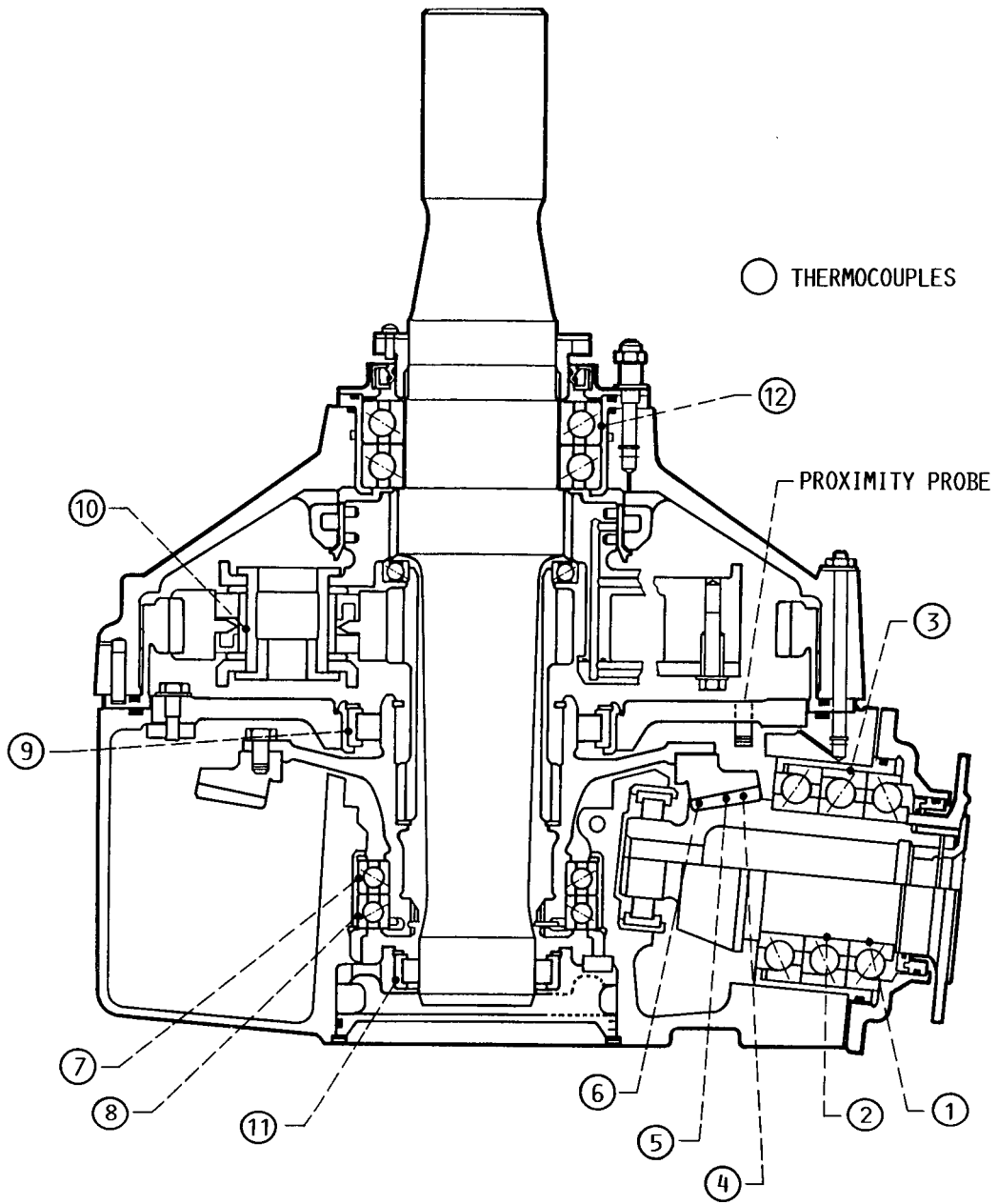

FIGURE 6. - PROXIMITY PROBE AND THERMOCOUPLE LOCATIONS IN ADVANCED TECHNOLOGY TRANSMISSION (LOCATIONS ALSO APPLY TO OH-58A).

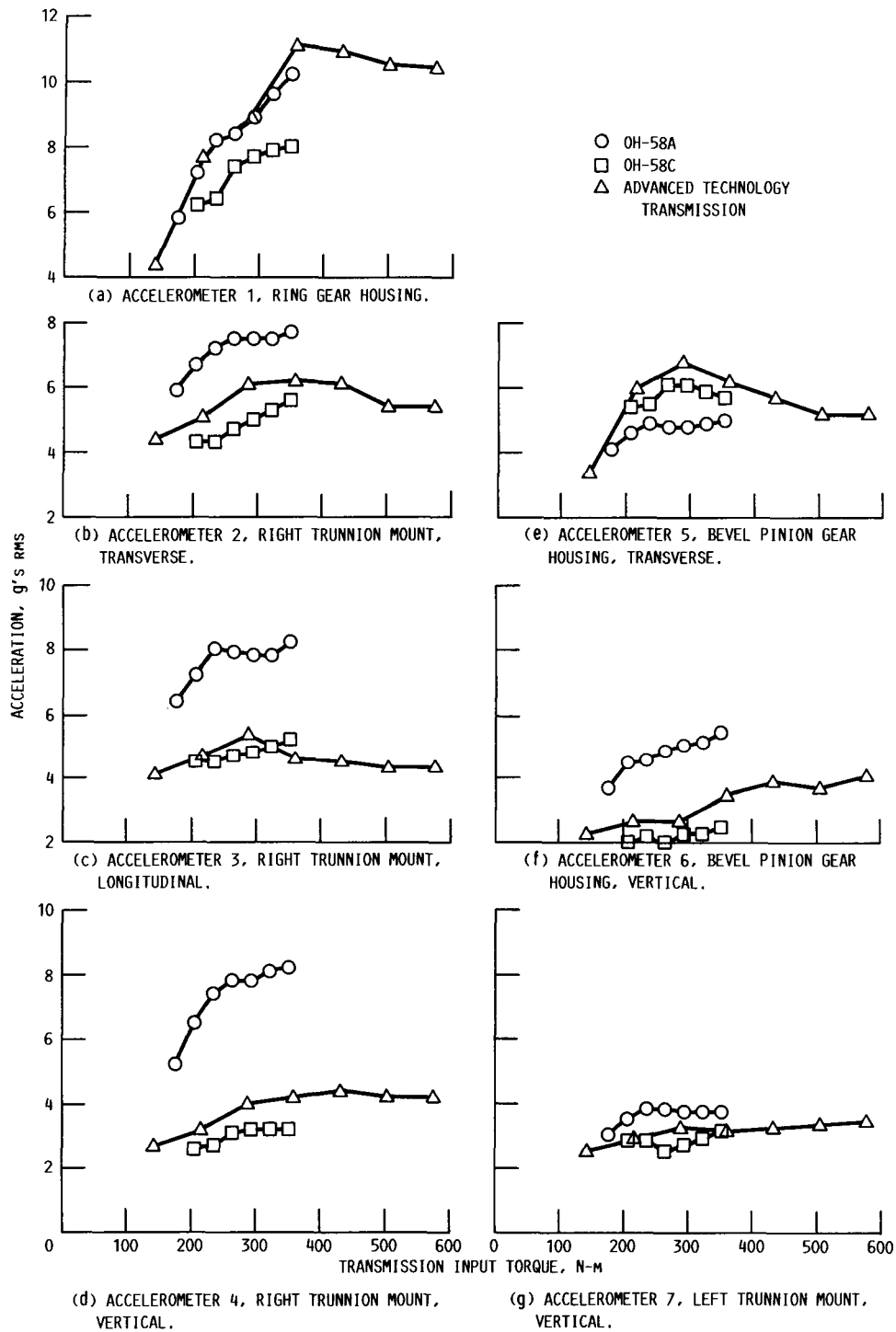
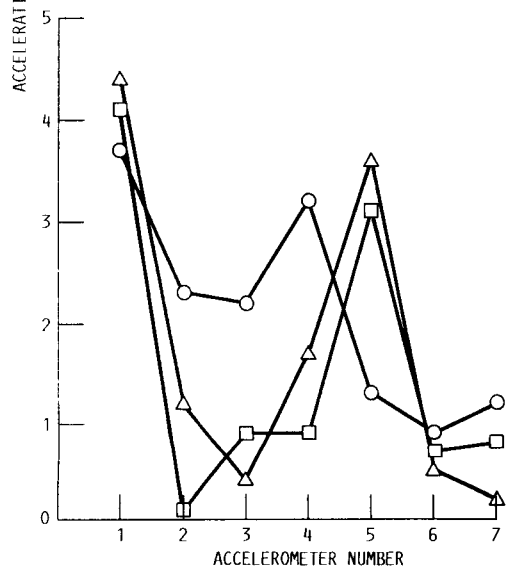
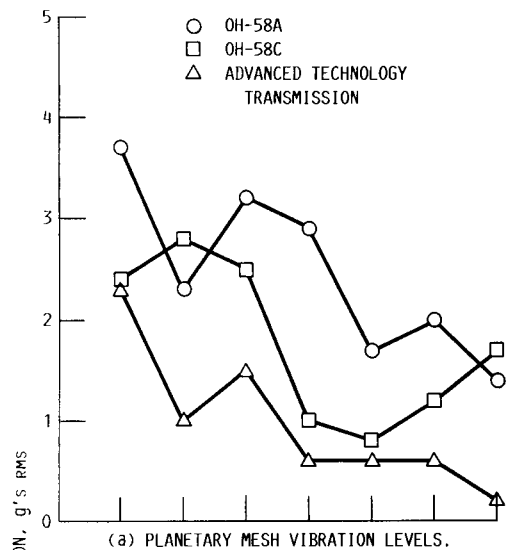
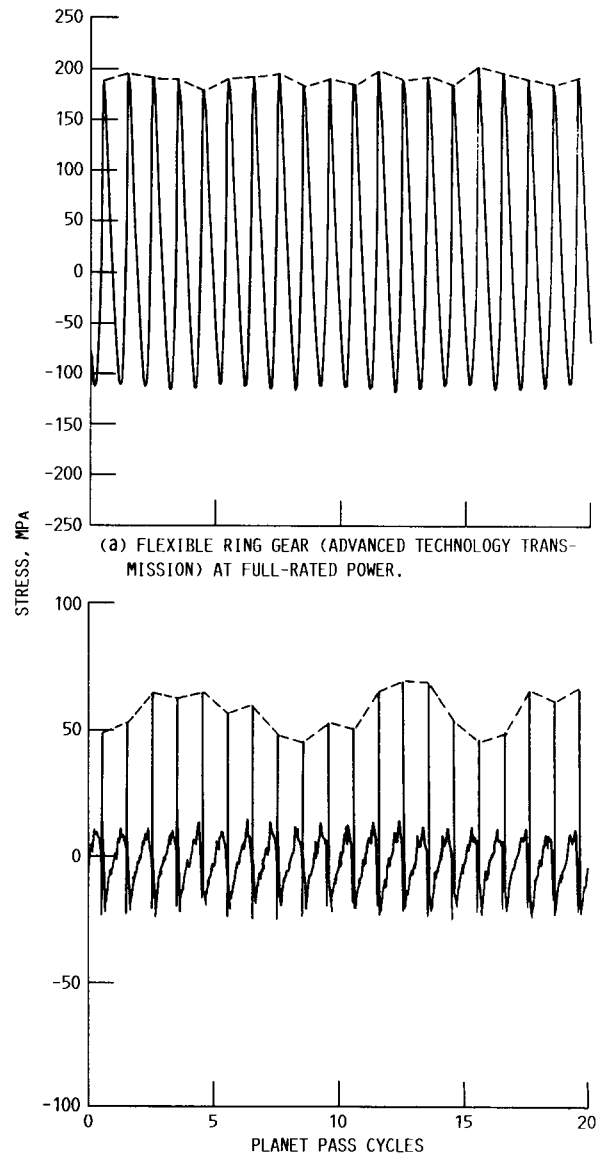

FIGURE 7. - TRANSMISSION VIBRATION LEVELS OF OH-58A, OH-58C, AND ADVANCED TECHNOLOGY TRANSMISSION AT FULL-RATED SPEED.



(a) PLANETARY MESH VIBRATION LEVELS.
 (b) SPIRAL-BEVEL MESH VIBRATION LEVELS.
 FIGURE 8. - PLANETARY AND SPIRAL-BEVEL MESH VIBRATION LEVELS OF OH-58A, OH-58C, AND ADVANCED TECHNOLOGY TRANSMISSION. OH-58A AND OH-58C AT 224 kW AND 6060 RPM, ATT AT 233 kW AND 6180 RPM.



(a) FLEXIBLE RING GEAR (ADVANCED TECHNOLOGY TRANSMISSION) AT FULL-RATED POWER.
 (b) RIGID RING GEAR (UH-60A TRANSMISSION) AT FULL-RATED POWER.

FIGURE 9. - RING GEAR STRESS OF ADVANCED TECHNOLOGY TRANSMISSION AND UH-60A TRANSMISSION AS AFFECTED BY PLANET GEARS PASSING STRAIN GAGES, INDICATING LOAD SHARING AMONG PLANETS.

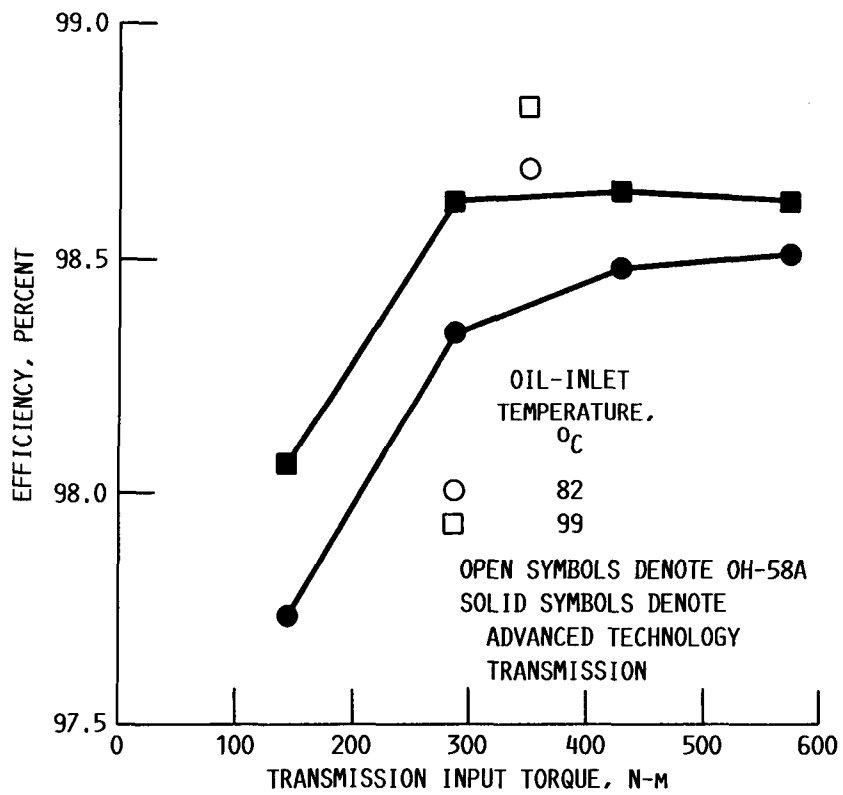

FIGURE 10. - MECHANICAL EFFICIENCIES OF OH-58A AND ADVANCED TECHNOLOGY TRANSMISSION AT FULL-RATED SPEED. LUBRICANT, TYPE K OF REFERENCE 5.

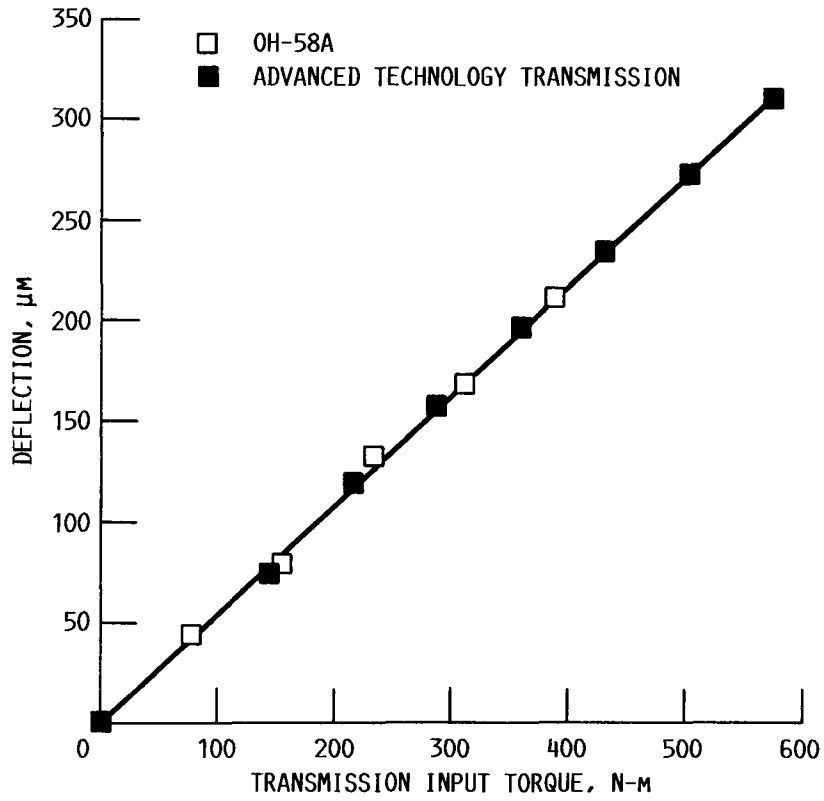

FIGURE 11. - MESH POINT BEVEL GEAR DEFLECTIONS IN VERTICAL DIRECTION FOR OH-58A AND ADVANCED TECHNOLOGY TRANSMISSION AT FULL-RATED SPEED.

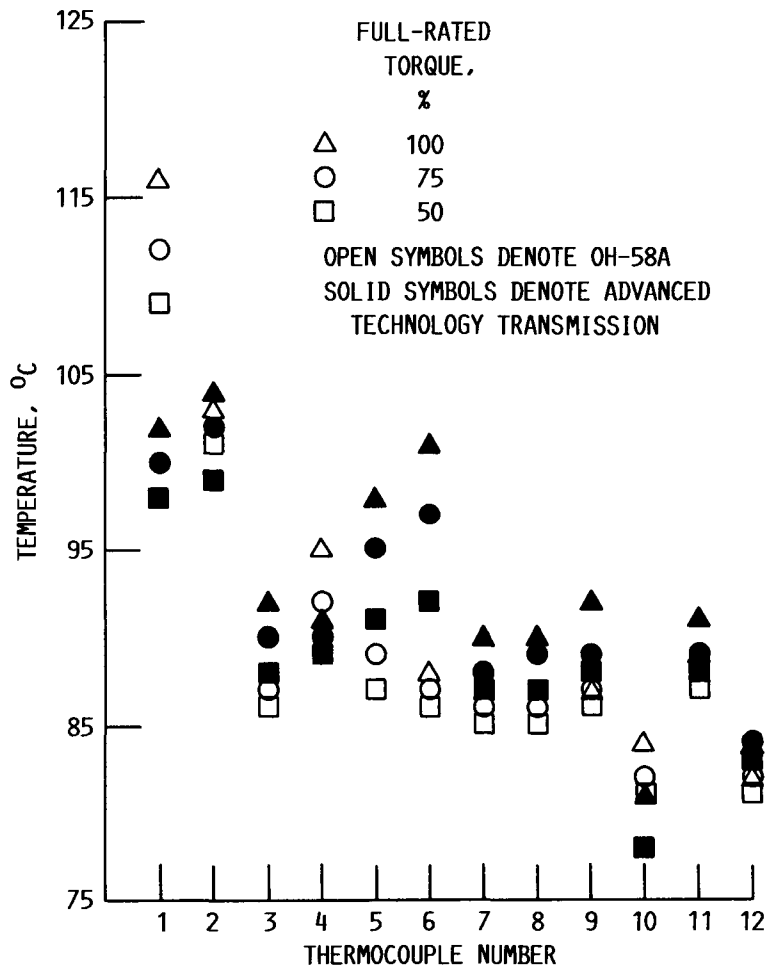

FIGURE 12. - COMPONENT TEMPERATURES OF OH-58A AND ADVANCED TECHNOLOGY TRANSMISSION AT FULL-RATED SPEED. TRANSMISSION OIL-INLET TEMPERATURE, 82 °C (180 °F). TRANSMISSION INSULATED.

1. Report No. NASA TM-101431 AVSCOM TR-87-C-38		2. Government Accession No.		3. Recipient's Catalog No.	
4. Title and Subtitle Effect of Advanced Component Technology on Helicopter Transmissions				5. Report Date	
				6. Performing Organization Code	
7. Author(s) David G. Lewicki and Dennis P. Townsend				8. Performing Organization Report No. E-4531	
9. Performing Organization Name and Address NASA Lewis Research Center Cleveland, Ohio 44135-3191 and Propulsion Directorate U.S. Army Aviation Research and Technology Activity--AVSCOM Cleveland, Ohio 44135-3127				10. Work Unit No. 1L161102AH45 505-63-51	
				11. Contract or Grant No.	
				13. Type of Report and Period Covered Technical Memorandum	
12. Sponsoring Agency Name and Address National Aeronautics and Space Administration Washington, D.C. 20546-0001 and U.S. Army Aviation Systems Command St. Louis, Mo. 63120-1798				14. Sponsoring Agency Code	
15. Supplementary Notes Prepared for the International Power Transmission and Gearing Conference sponsored by the American Society of Mechanical Engineers, Chicago, Illinois, April 25-27, 1989. David G. Lewicki, Propulsion Directorate; Dennis P. Townsend, NASA Lewis Research Center.					
16. Abstract Experimental tests were performed on the NASA/Bell Helicopter Textron (BHT) 500-hp advanced technology transmission (ATT) at the NASA Lewis Research Center. The ATT was a retrofit of the OH-58C helicopter 236-kW (317-hp) main rotor transmission, upgraded to 373 kW (500 hp), with a design goal of retaining long life with a minimum increase in cost, weight, and size. Vibration, strain, efficiency, deflection, and temperature experiments were performed and the results were compared to previous experiments on the OH-58A, OH-58C, and UH-60A transmissions. The high-contact-ratio gears and the cantilever-mounted, flexible ring gear of the ATT reduced vibration compared to that of the OH-58C. The ATT flexible ring gear improved planetary load sharing compared to that of the rigid ring gear of the UH-60A transmission. The ATT mechanical efficiency was lower than that of the OH-58A transmission, probably due to the high-contact-ratio planetary gears.					
17. Key Words (Suggested by Author(s)) Transmission; Gears; Bearings; Transmission testing; Efficiency; Vibration; Strain; Deflections; Helicopters; High-contact-ratio gears			18. Distribution Statement Unclassified--Unlimited Subject Category 37		
19. Security Classif. (of this report) Unclassified		20. Security Classif. (of this page) Unclassified		21. No of pages 18	22. Price* A03