

N89 - 14168

1988

NASA/ASEE SUMMER FACULTY RESEARCH FELLOWSHIP PROGRAM

JOHN F. KENNEDY SPACE CENTER  
UNIVERSITY OF CENTRAL FLORIDATRANSMISSION OF MULTIPLEXED VIDEO SIGNALS  
IN MULTIMODE OPTICAL FIBER SYSTEMS

Prepared By: Preston White III

Academic Rank: Associate Professor

University and Department: Southern College of Technology  
Electrical and Computer  
Engineering Technology

NASA/KSC:

Division: Electronic Systems Support

Branch: Communications

NASA Counterpart: Perry Rogers, Larry Hand

Date: August 1988

Contract No.: University of Central Florida  
NASA-NGT-60002

## TABLE OF CONTENTS

<u>Section</u>	<u>Title</u>
I	INTRODUCTION . . . . .
1.1	Fiberoptic Communication . . . . .
1.2	Video Transmission . . . . .
1.3	Distances . . . . .
1.4	Research Goal . . . . .
II	BANDWIDTH . . . . .
2.0	System Considerations . . . . .
2.1	Fiber Bandwidth . . . . .
2.2	LED Transmitter Bandwidth . . . . .
2.3	PINFET Receiver Bandwidth . . . . .
2.4	Overall Available Bandwidth . . . . .
III	OPTICAL MULTIPLEXING . . . . .
3.0	Wavelength Division Multiplexing . . . . .
IV	ELECTRICAL MULTIPLEXING . . . . .
4.0	Candidate Multiplexing Schemes . . . . .
4.1	Scheme 1: FM / Frequency Division Multiplexing
4.2	Scheme 2: AM / Frequency Division Multiplexing
4.3	Scheme 3: Quadrature Amplitude Modulation . . .
V	PERFORMANCE ANALYSIS . . . . .
5.0	Frequency Modulation and S/N Performance . . .
5.1	Scheme 1: FM / FDM . . . . .
5.1.1	Theoretical Analysis . . . . .
5.1.2	Laboratory Tests . . . . .
5.1.3	Scheme 1 Results . . . . .
5.2	Scheme 2: AM / FDM . . . . .
5.2.1	Theoretical Analysis . . . . .
5.2.2	Laboratory Tests . . . . .
5.2.3	Scheme 2 Results . . . . .
5.3	Scheme 3: QAM . . . . .
5.3.1	Theoretical Analysis . . . . .
5.3.2	Laboratory Tests Unavailable . . . . .
5.3.3	Further Tests Desirable . . . . .
VI	CONCLUSIONS . . . . .
6.0	Scheme 1 Is Most Promising . . . . .
6.1	Further Studies Recommended . . . . .
VII	ACKNOWLEDGMENTS . . . . .
VIII	REFERENCES . . . . .

## LIST OF ILLUSTRATIONS

<u>Figure</u>	<u>Title</u>
2-1	Fiberoptics Cable Installation . . . . .
2-2	Fiber Bandwidth Test Configuration . . . . .
2-3	Bandwidth Testset Hardcopy Output . . . . .
4-1	Scheme 1: FM/FDM . . . . .
4-2	Scheme 2: AM/FDM . . . . .
4-3	Scheme 3: QAM . . . . .
5-1	Laboratory Tests Scheme 1 - FM/FDM . . . . .
5-2	High-level FM/FDM Signal . . . . .
5-3	Low-level FM/FDM Signal . . . . .
5-4	Carriers After Transmission . . . . .
5-5	LED E-O Characteristic . . . . .
5-6	Comparison of FM/FDM Predicted & Measured S/N
5-7	Laboratory Tests Scheme 2 - AM/FDM . . . . .
5-8	Baseband+T7 Signal Used in Laboratory Tests .
5-9	Performance of AM/FDM Baseband+T7 Tests . . .
5-10	QAM Phase Sensitivity . . . . .

## LIST OF TABLES

<u>Table</u>	<u>Title</u>
2-1	Results of Selected Fiber Bandwidth Tests . . .
2-2	PINFET Receiver Specifications . . . . .
5-1	Choice of FM Peak Deviation . . . . .
5-2	Prediction of S/N Performance for FM/FDM . . .
5-3	Optimum S/N Performance of AM/FDM . . . . .

## ABSTRACT

Kennedy Space Center has the need for economical transmission of two multiplexed video signals along multimode fiberoptic systems. These systems must span unusual distances and must meet RS-250B short-haul standards after reception. Bandwidth is a major problem and studies of the installed fibers, available LEDs and PINFETs led to the choice of 100 MHz as the upper limit for the system bandwidth.

Optical multiplexing and digital transmission were deemed inappropriate. Three electrical multiplexing schemes were chosen for further study. Each of the multiplexing schemes included a FM stage to help meet the stringent S/N specification.

Both FM and AM frequency division multiplexing methods were investigated theoretically and these results were validated with laboratory tests. The novel application of quadrature amplitude multiplexing was also considered.

Frequency division multiplexing of two wideband FM video signal appears the most promising scheme although this application requires high power and highly linear LED transmitters.

Further studies are necessary to determine if LEDs of appropriate quality exist and to better quantify performance of QAM in this application.

## SECTION I

### INTRODUCTION

#### 1.1 FIBEROPTIC COMMUNICATION

Communication along optical fibers is a development that has experienced rapid growth worldwide in the fifteen years since its inception. Kennedy Space Center has long been interested in fiberoptic technologies and has chosen optical fibers to be the medium for some communication applications. According to some accounts, Kennedy Space Center has more installed optical fiber than any other single location in the world. The reasons for KSC's interest in fiberoptics closely parallel the well-known advantages of fiberoptics: small size and light weight, very high bandwidth, growth potential and corrosion resistance.

Some of the applications of fiberoptic communications at KSC are unique to the location. Of these, the application of this technology to the transmission of very-high-quality video signals is growing and presents interesting problems. There are hundreds of video sources at the Space Center and the users of the various video services are even more numerous. These sources and users form a complex and dynamic network where the interconnect requirements vary constantly to support various Shuttle operations, expendable booster operations, the various payloads and for special projects.

#### 1.2 VIDEO TRANSMISSION

Video signals are highly complex. The transmission of these signals in analog form places stringent requirements on the signal-to-noise, linearity and delay characteristics of video communication systems. At this time, digital video transmission requires high bandwidth and very expensive coders and decoders and is not appropriate for space center applications.

Some of the operations at KSC require the transport and distribution of the highest quality video signals obtainable. The performance standards for judging the quality of video communication systems are given in EIA Standard RS-250B. Within this standard, several levels of transmission quality are defined. The most stringent level, named "short-haul", is most commonly applied to the video signals available within a television studio. It is the goal at the Space Center that the video signals conveyed along optical fiber systems meet the studio-quality, short-haul standards at the fiberoptic receiver.

### 1.3 DISTANCES

Due to its size, the transmission distances involved at Kennedy Space Center are unusual when compared to most commercial applications of fiberoptic technology. Commercial fiberoptic system designs usually assume about a 10-km limit on the distances spanned by low cost systems; that is, systems utilizing LED-based transmitters, multimode optical fibers and PINFET-based receivers. On the other hand, distances of 60-km or more are available using the more expensive technology: laser transmitters, singlemode fiber and APD receivers. The distances at KSC (for example: 9.8-km from the O&C building to the LCC, 17-km from O&C to Pad 39B) are not the most appropriate distances for either of these well-developed technologies.

Even with the large amount of fiber installed or planned for KSC, it is thought that in the future, communications needs will necessitate better utilization of the available bandwidth of each of the fibers. This is especially true of the multimode fibers. Currently, when space center video signals are transported by fiber it is on a one-channel per multimode fiber basis, leaving a great deal of fiber bandwidth unused. For this reason it is desirable to develop the ability to transport two short-haul quality video channels per multimode fiber.

Although commercial fiberoptic equipment exists for the transport of several video signals per fiber this equipment is designed for the CATV industry. CATV equipment is not appropriate for KSC's needs for three reasons. First, the design of this equipment maximizes the number of channels transmitted per fiber at the expense of the quality of the signal. Therefore, although this equipment performs acceptably for its primary use, the signal quality at the receiver usually does not meet the short-haul standards needed by the Center. Second, this equipment is based upon the laser and singlemode fiber technology and the need at the Center is to better use the bandwidth of the existing multimode fibers. And third, the commercial equipment is usually limited to the transport of standard NTSC video signals. At KSC the desire is to reserve 12-MHz channel width (double the usual spacing) in order to have the ability to transport high-resolution CCTV signals, digital data and also to facilitate upgrade to high-definition video when that standard becomes available.

### 1.4 RESEARCH GOAL :

The purpose of this research project was to study possible designs of fiberoptic transmitter and receiver terminal equipment

which will use some multiplexing scheme to simultaneously transmit two video signals along a fiberoptic link and also satisfy the following:

- (1) Use the 50/125 multimode fiber like that installed at Kennedy Space Center.
- (2) Use 1300-nm LED transmitters.
- (3) Use PINFET-based receivers.
- (4) Reserve 12-MHz capability for each video channel.
- (5) Meet RS-250B short-haul specifications at the receiver.

At the end of this project it is intended that the multiplexing method that would most likely to meet these criteria will be identified. Later it is supposed that this information will lead to the generation of a Request For Quotation for the fiberoptic equipment that will meet this need.

SECTION II

BANDWIDTH

2.0 SYSTEM CONSIDERATIONS

Although the bandwidth of multimode optical fibers is high, it was clear early in the project that any possible electrical multiplexing scheme would require a high bandwidth. For that reason one of the first questions to be answered early in the study was to determine what bandwidth is actually available in the multimode fiber links at KSC. The usable bandwidth of the links would be limited by a combination of the fiber bandwidth and the bandwidth of the commercially available LED transmitters and PINFET receivers. Each of these limiting factors was studied.

2.1 FIBER BANDWIDTH

The 50/125  $\mu\text{m}$  multimode fiber links interconnect many of the buildings at KSC and typically include fusion splices (every 2-km or so) between the buildings and terminate at patch-panels inside of the buildings. Figure 2-1 illustrates the fiberoptic cable plant installed or planned at KSC.

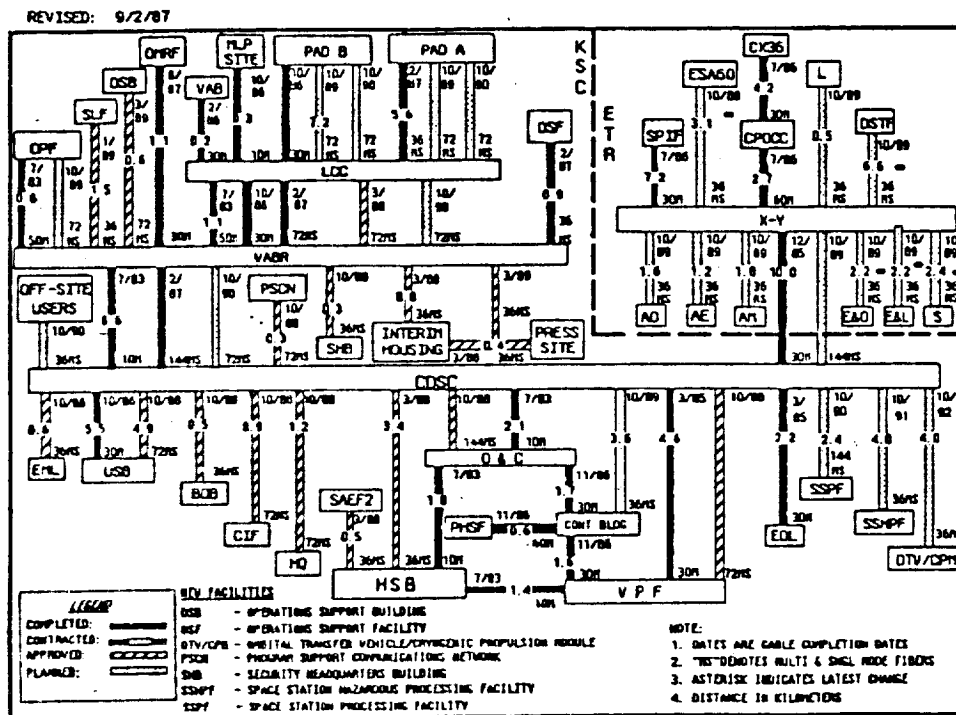

Figure 2-1. Fiberoptic Cable Installation



Current design practices assume that multimode fibers have constant bandwidth-length products and these products are specified by the manufacturers. If this is so, then the available fiber bandwidth varies inversely with the fiber length, as shown in equation (1):

$$B_x = \frac{BL}{l} \quad (1)$$

where:  $B_x$  = the 3-dB bandwidth of the fiber  
 $BL$  = the bandwidth-length product  
 $l$  = the length of the fiber

Manufacturer's tests show that equation (1) will normally underestimate the actual bandwidth of installed fiber. Furthermore any disturbance (connectors, splices, tight bends, stress, etc.) along the fiber will cause a change in the power distribution among the modes which will change the fiber's bandwidth. It was determined that tests would be necessary to better understand the actual bandwidth of the center's multimode fibers.

A Tektronix OF190 Bandwidth Test Set was obtained for the purpose of testing a sample of the Center's fibers. This instrument measures the attenuation and electrical bandwidth (using the swept-frequency method) of multimode fibers. The tests were performed at the CDSC building on several fiber pairs that were looped back at patch-panels in the VABR. The test configuration is diagramed in Figure 2-2 and an example of the hardcopy output of the OF190 is shown in Figure 2-3.

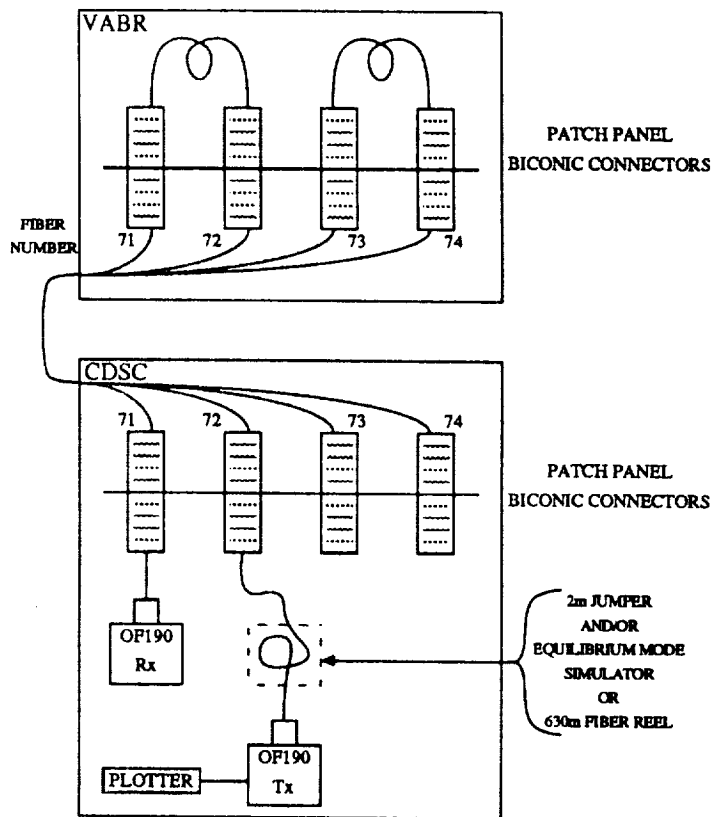
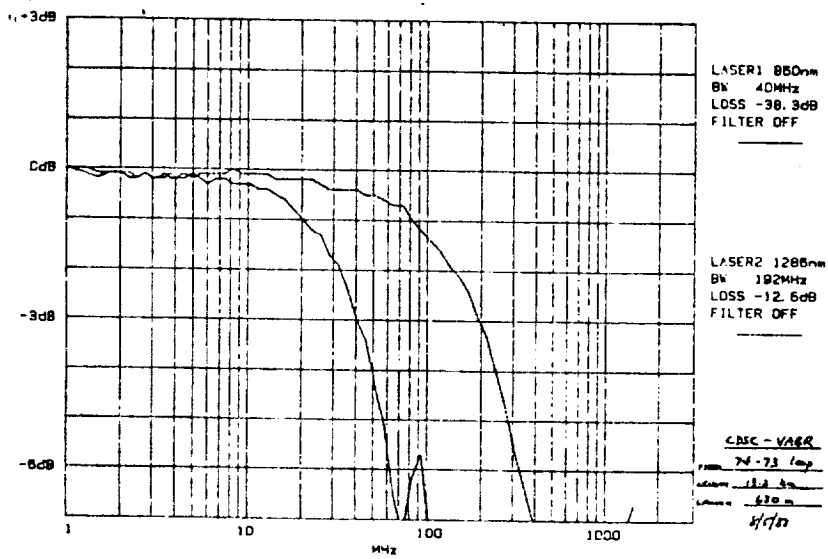

Figure 2-2. Fiber Bandwidth Test Configuration



OF192

Figure 2-3. Bandwidth Testset Hardcopy Output

Some selected results of these tests are given in Table 2-1. There are some interesting results in the table. The contract for the cable containing fibers 71, 72, 73 and 74 specified a minimum bandwidth·length product of 1000 MHz·km. As Table 2-1 shows, the actual bandwidth·length product of the test loops exceeded the specification by 50 to 150%. The effect of mode-scrambling due to connectors is shown by comparing the attenuation and the bandwidth in "74-73" tests for different launch conditions (the EMS is an equilibrium mode simulator). Evidently the 2-m patch cord caused a loss that affected the high-order modes predominately since the patch cord produced an increase in the attenuation combined with an increase in bandwidth.

Table 2-1. Results of Selected Fiber Bandwidth Tests

Fiber Cable	Fiber Numbers	dist (km)	launch		1300 nm	
			2-m patch	EMS	atten (dB)	BW (MHz)
144MS  2/87	74-73	13.2	X	X	16.3	218
				X	12.5	201
	73-74	13.2	X	X	15.5	224
				X	13.2	189
	71-72	13.2		X	12.0	116
	72-71		X	X	16.9	117
	74-72- 73-71	26.4	X	X	26.3	85

Another interesting result was a 50% difference in the bandwidths between nominally identical fibers. Further testing would be necessary to understand why this difference is so large. However, in all but the very longest link, the bandwidth of the fiber path was in well in excess of 100 MHz and should allow the transport of the desired multiplexed video signal.

## 2.2 LED TRANSMITTER BANDWIDTH

In order to be useful over the distances required at KSC, the LED transmitters should be able to couple a minimum of 50  $\mu$ W of power into the 50/125- $\mu$ m fibers. Devices are available which will provide this power and which have risetimes in the vicinity of 2-3 ns (bandwidths of 120-180 MHz). For example, the LED

transmitter that was used in all of the laboratory tests described in Section 5 was a Stantel Components Inc. model LH44A-19. This device had a risetime specification of 2.5 ns, and coupled -16 dBm into the 50/125  $\mu$ m pigtail. These specifications were confirmed in the laboratory. The device is thought to be sufficiently fast for this multiplexed video application although more power is desirable.

### 2.3 PINFET RECEIVER BANDWIDTH

The PINFET receiver is considered to be the most appropriate choice for this application since these receivers combine acceptable sensitivity, bandwidth and dynamic range with economy. The receiver used for all of the laboratory tests was model RTZ-140-80C-MHZ manufactured by PCO, Inc. This device is representative of a family of receivers that typify the products available today. The performance specifications of this receiver are listed in Table 2-2. A higher bandwidth version of the receiver is also shown in the table since it is thought that this receiver would be more appropriate to the multiplexed video links. Attempts to obtain one of these receivers to use in the laboratory tests were unsuccessful.

Table 2-2. PINFET Receiver Specifications

	PINFET used in lab tests	PINFET with higher bandwidth
Model	RTZ-140-80-MHz	RTZ-200-140-MHz
Bandwidth	80 MHz	140 MHz
Noise Floor	-50 dBm	-48 dBm
Responsivity	35 mV/ $\mu$ W	25 mV/ $\mu$ W
Transimpedance	50 k $\Omega$	35 k $\Omega$
Noise Figure	<2	<2
Dynamic Range	29 dB	29 dB

### 2.4 OVERALL AVAILABLE BANDWIDTH

The result of the bandwidth investigations is that a link electrical bandwidth of 100 MHz is readily obtainable with available technology. For this reason 100 MHz was used as the target limit for the bandwidth for the subsequent multiplexing investigations.

SECTION III  
OPTICAL MULTIPLEXING

3.0 WAVELENGTH DIVISION MULTIPLEXING

In order to simultaneously place two wide-bandwidth video channels on each fiber, some multiplexing scheme needs to be chosen. This multiplexing could be done in the electrical domain before the LED or optically after the LED. The most popular optical multiplexing scheme is wavelength division multiplexing (WDM). For WDM each signal would intensity modulate a separate LED then the two beams would be optically combined and coupled into the fiber. The two LEDs would have to be chosen to possess optical spectra that were in the 1300-nm window but did not overlap (850-nm is not appropriate due to high attenuation at this wavelength). At the exit aperture of the fiber, the different color beams are first optically separated and then each beam is sent to its own PINFET.

The expense of wavelength division multiplexing makes it inappropriate for this application. The expense arises from the need for separate LEDs and PINFETs for each video channel, from the optical couplers necessary at the fiber ends and from the stringent requirements placed on the spectrum of each LED.

It was determined that for this application the multiplexing of the video signals would be done electrically, using some sort of RF technique. Once the channels were electrically combined the complex signal would then intensity modulate a single LED. One PINFET would be used to reconvert the optical signal back into the complex electrical signal which would then be electrically demultiplexed and each channel processed separately. If successful, RF multiplexing would satisfy the need to better utilize the multimode fiber bandwidth and be much less expensive than optical multiplexing.

SECTION IV

ELECTRICAL MULTIPLEXING

4.0 CANDIDATE MULTIPLEXING SCHEMES

Meetings early in the project identified three candidate RF multiplexing schemes which were thought worthy of investigation. Each of these schemes is briefly described in this section and the results of these investigations are detailed in Section 5.

4.1 SCHEME 1: FM / FREQUENCY DIVISION MULTIPLEXING

For this method, each video signal would first be wideband frequency modulated onto a different carrier and then the two FM spectra would be combined into a frequency division multiplexed (FDM) signal that would be used to intensity modulate an LED. This FM/FDM scheme is diagrammed in Figure 4-1. After conversion back to a complex electrical signal at the receiver, filtering would separate the two FM spectra which would then be demodulated by ordinary means.

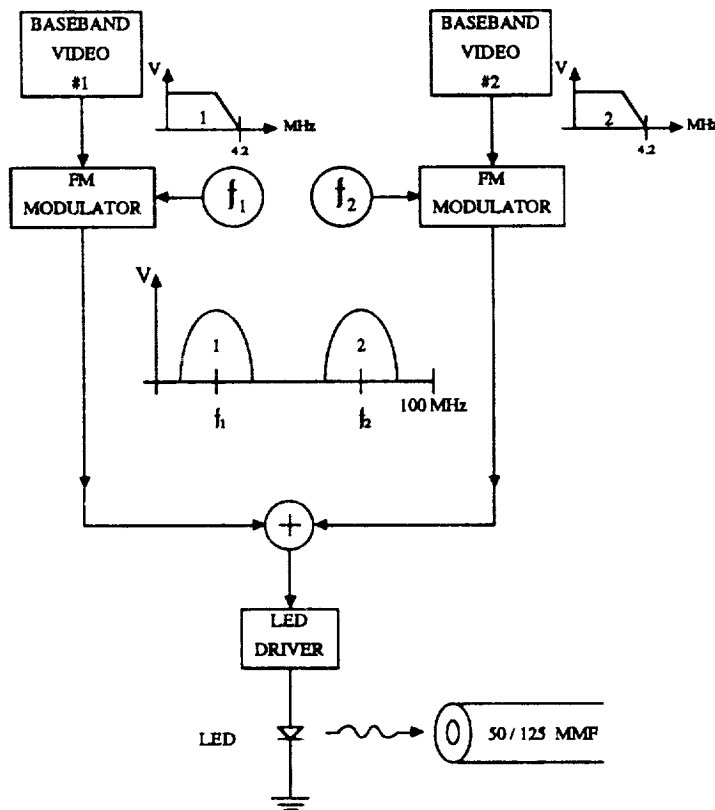

Figure 4-1. Scheme 1: FM/FDM

C-b

The wideband frequency modulation will be shown to be necessary in order to gain the S/N improvement that can be realized using this modulation (and its associated preemphasis). This S/N improvement seems necessary in order to meet the short-haul S/N specification (67 dB weighted) over useful distances. The FM carrier frequencies and deviations would need to be chosen to maximize the channel separation and S/N and to keep the multiplexed bandwidth smaller than 100 MHz.

#### 4.2 SCHEME 2: AM / FREQUENCY DIVISION MULTIPLEXING

For this method, frequency division multiplexing would be used to combine two video signals initially. The scheme is diagrammed in Figure 4-2. One channel would be left as an AM baseband signal and the second would be single-sideband modulated to a higher frequency. After these AM signals are mixed, the combination would be wideband frequency modulated. Again, the reason for the FM modulation is to gain some FM S/N improvement.

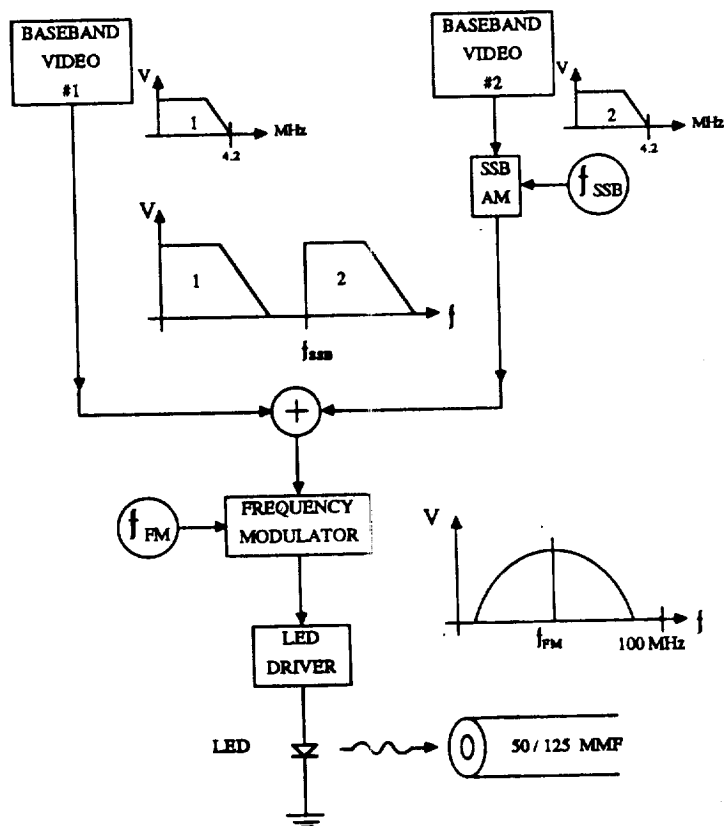

Figure 4-2. Scheme 2: AM/FDM

### 4.3 SCHEME 3: QUADRATURE AMPLITUDE MODULATION

In ordinary AM, the upper and lower sidebands carry redundant information. By using a variation of AM called Quadrature Amplitude Modulation (QAM), two baseband signals can be combined into one AM spectrum, in effect, the two signals are "phase" multiplexed onto an IF carrier. This scheme would use QAM to combine the baseband channels and then would frequency modulate the resulting signal. A block diagram of this scheme is shown in Figure 4-3.

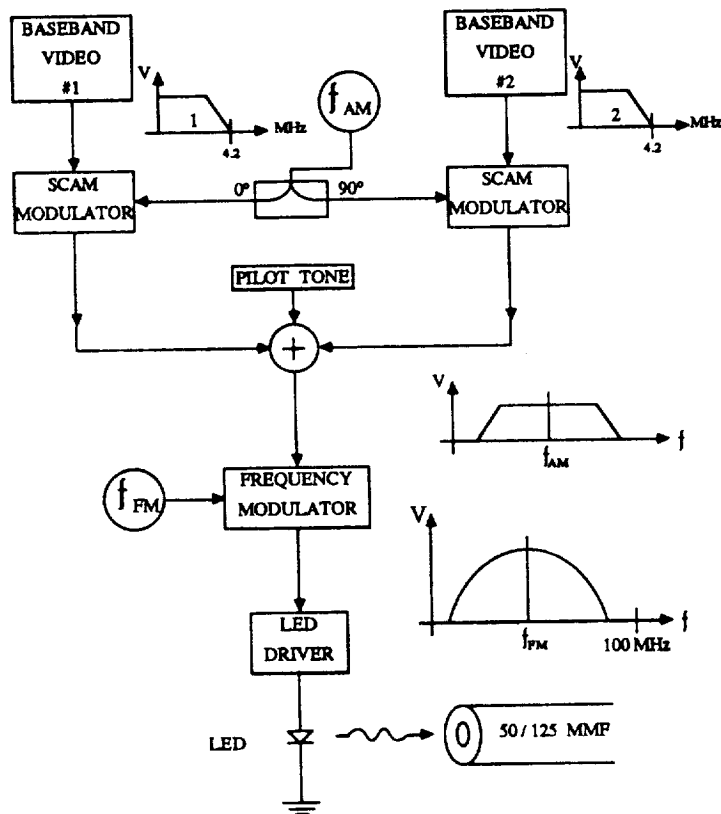

Figure 4-3. Scheme 3: QAM

The quadrature amplitude modulation is accomplished by suppressed-carrier amplitude modulating each baseband signal onto coherent carriers which are in phase quadrature. Separation of the two signals at the receiver is accomplished by coherent detection and necessitates the local generation in the receiver of a carrier pair that is identical to those used in the modulator. The generation of these carriers can be accomplished only if a pilot tone is included in the transmission and is made available for phase-lock reference at the receiver.



## SECTION V

### PERFORMANCE ANALYSIS

#### 5.0 FREQUENCY MODULATION AND S/N PERFORMANCE

Frequency modulation is at some point common to all of the three schemes. The S/N improvement associated with wideband FM is necessary to provide the ability to meet the short-haul S/N specification after the optical signal has passed through several kilometers of fiber, and becomes especially important when the optical power is divided between two independent channels. The S/N improvement inherent in wideband FM is gained at the expense of a FM signal spectrum that is broader than that of the original signal. The wider bandwidth and S/N improvement are set by the choice of peak FM deviation. Since the total transmission system bandwidth is likely to be only 100 MHz, a balance between the S/N improvement and the overall bandwidth must be established. The improvement figure and an estimate of the increased bandwidth are found from formulas (2) and (3)<sup>(1), (2)</sup>:

$$I_{FM} = 4.77 + 20 \log(f_P/b) \quad (2)$$

$$B_{FM} = 3(f_P + b) \quad (3)$$

where  $I_{FM}$  = the S/N improvement in dB  
 $f_P$  = the peak deviation of FM signal  
 $b$  = highest baseband frequency to FM modulator  
 $B_{FM}$  = bandwidth estimate of the FM spectrum

The signal-to-noise estimate (0.7  $V_{PP}$  to rms noise) of the performance of FM transmitted video signals is given by<sup>(3)</sup>:

$$\frac{S}{N} = 3 \cdot (C/N) \cdot \left| \frac{2f_P}{b} \right|^2 \cdot E \quad (4)$$

where:  $C/N$  = is computed from (5)  
 $f_P$  = peak FM deviation represented by the "signal" portion of the waveform  
 $b$  = the bandwidth of the baseband signal  
 $E$  = is the preemphasis factor

The carrier to noise ratio for the electrical signals available from an ac-coupled PINFET receiver which incorporates a transimpedance preamplifier can be estimated by<sup>(4)</sup>:

$$\frac{C}{N} = \frac{m^2 \cdot (RP)^2 \cdot R_x}{2 \cdot (4kTb) \cdot F_n} \quad (5)$$

- where: m = the effective optical modulation depth  
R = the responsivity of the PIN photodiode  
P = optical power at the PIN  
k = Boltzman's constant  
T = Kelvin temperature of the PINFET  
F<sub>n</sub> = the noise figure of the FET preamplifier  
R<sub>x</sub> = the transimpedance of the preamplifier

The optical modulation factor represents the fraction of the peak received power that is modulated. If only one signal is being transmitted and if the transmitting LED is highly linear, then modulation across the entire characteristic is possible and m could equal unity. However; if two signals are being combined and used to modulate the LED the the effective optical modulation depth for each channel would be a fraction. If the phase relation between the voltage waveforms of the signals is random, then the signals could be combined on an electrical power basis and m = 0.7; however, in the worst case, the waveforms would combine on a voltage basis and m = 0.5.

Table 5-1 shows the relationship between the peak deviation chosen for an FM modulator, the expected S/N improvement (without preemphasis) and the RF spectrum. By using the CCIR 405 preemphasis curve, an additional improvement of 13 dB can be expected above that shown in the table. The table assumes a highest baseband frequency of 4.2 MHz. In the future 12-MHz HDTV signals could accommodated by a reduction in the peak deviation; however, the S/N performance would suffer.

Table 5-1  
Choice of FM Peak Deviation

peak deviation (MHz)	FM improvement (dB)	bandwidth (MHz)
2	none	18.6
4	4.35	24.6
6	7.87	30.6
8	10.37	36.6

## 5.1 SCHEME 1: FM / FDM

### 5.1.1 THEORETICAL ANALYSIS

Using the above information and using the specifications of the PCO PINFET receiver RTZ-140-80C-MHz (see section 2.3) the following estimates of the unweighted signal-to-noise performance for a FM/FDM link were determined. Table 5-2 summarizes the results of these calculations at various received power levels and compares baseband channel widths of 4.2 MHz (NTSC standard) and 12 MHz (possible future HDTV). For both cases, the peak-to-peak deviation was chosen to be 8 MHz and the CCIR 405 preemphasis curve was applied.

Table 5-2  
Prediction of S/N Performance for FM/FDM

input power (dBm)	4.2 MHz Baseband		12 MHz Baseband	
	C/N (dB)	S/N unwtd (dB)	C/N (dB)	S/N unwtd (dB)
-40	23.4	46.7	18.9	33.0
-36	31.4	54.7	26.9	41.0
-30	43.4	66.7	38.9	53.0
-25	53.4	76.7	48.9	63.0
-20	63.4	86.7	58.9	73.0

### 5.1.2 LABORATORY TESTS

Laboratory tests were made possible by modifying some existing equipment as shown in Figure 5-1. Electrical modulation and frequency translation of the video signals was performed by modules from American Lightwave Systems Inc. At the transmit end two baseband video test signals were FM modulated to 70-MHz carriers (4 MHz peak deviation) using model FM-6200-VM modulators and then the FM spectra were translated using model FM-6600-MX modules to 52.5 (Ch 0) and 87.5 MHz (Ch 1). At the receive end, the opposite conversions were made using two model FM-6600-DMX demultiplexers and two model FM-6200-VD demodulators.

The electro-optic devices and the associated drive and bias circuitry were excised from the single channel per multimode fiber 5000-series modules manufactured by PCO, Inc and were further described in Section 2.

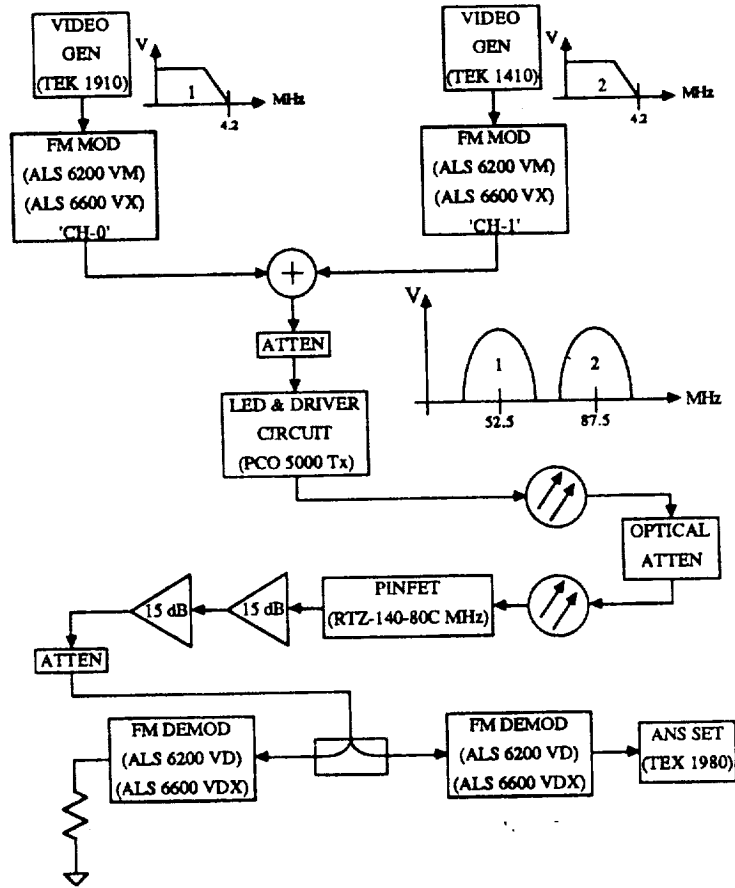

Figure 5-1. Laboratory tests  
Scheme 1 - FM/FDM

At first, the levels of the combined FM signals were adjusted to give an electrical drive signal that matched the drive used in the PCO equipment, 300 mV<sub>pp</sub> at the input to the drive circuit. This level produces a large optical modulation depth ( $\approx 100\%$ ). A large amount of intermodulation distortion was observed on the video test equipment. The effect of the optical modulation and detection can be seen in Figure 5-2 which shows the electrical spectrum that was fed to the LED driver circuit and the electrical signal after reception and conversion by the PINFET. A significant feature of the received spectrum is that the second harmonic of the high-frequency channel is only about 25 dB below the fundamental. Even more significant is the fact that the levels of the sum and difference intermodulation products are only -20 dB and  $< -5$  dB respectively (referenced to the fundamental).

ORIGINAL PAGE IS  
OF POOR QUALITY

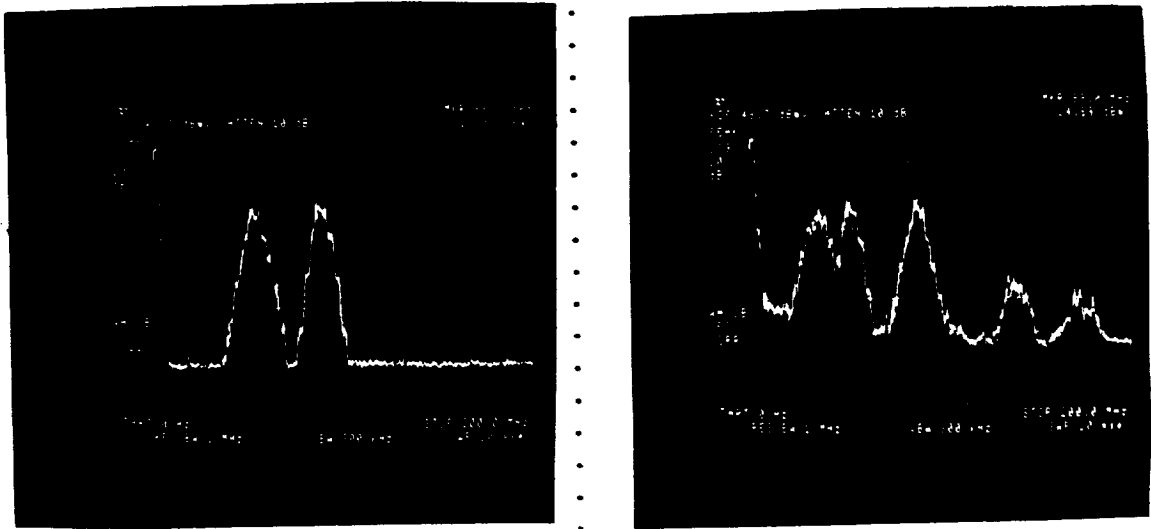

Figure 5-2. High-level FM/FDM Signal Before (left) and After (right) Optical Transmission

Lowering the modulation depth to approximately 20% (by lowering the drive signal to 50 mV<sub>PP</sub>) dramatically decreased the intermodulation products as can be seen in the post-PINFET spectrum shown in Figure 5-3.

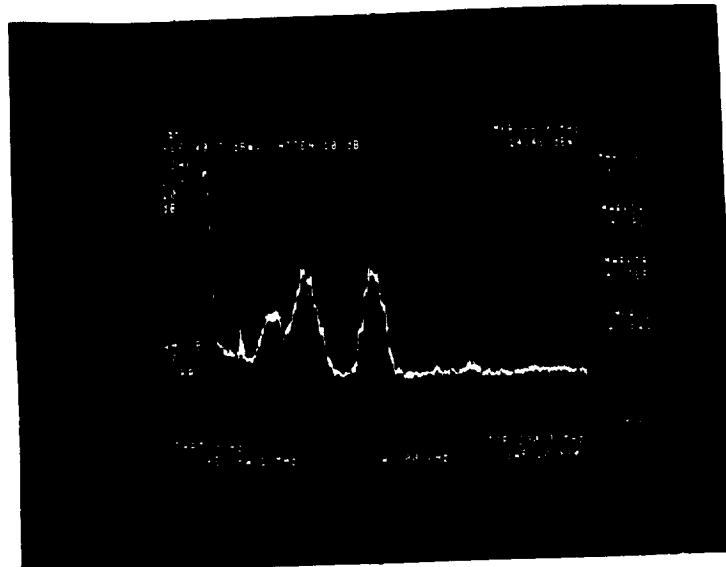

Figure 5-3 Low-level FM/FDM Signal After Optical Transmission

In order to understand the relationship of modulation depth and harmonic and intermodulation distortion, spectral analysis of the PINFET's electrical output was done with modulated and with unmodulated carriers at various modulation depths. Figure 5-4 shows the PINFET output for both 100% and 20% approximate optical modulation when only the carriers are present. Reducing the optical modulation significantly diminished the harmonic and intermodulation products. The difference product was reduced to -10 dB.

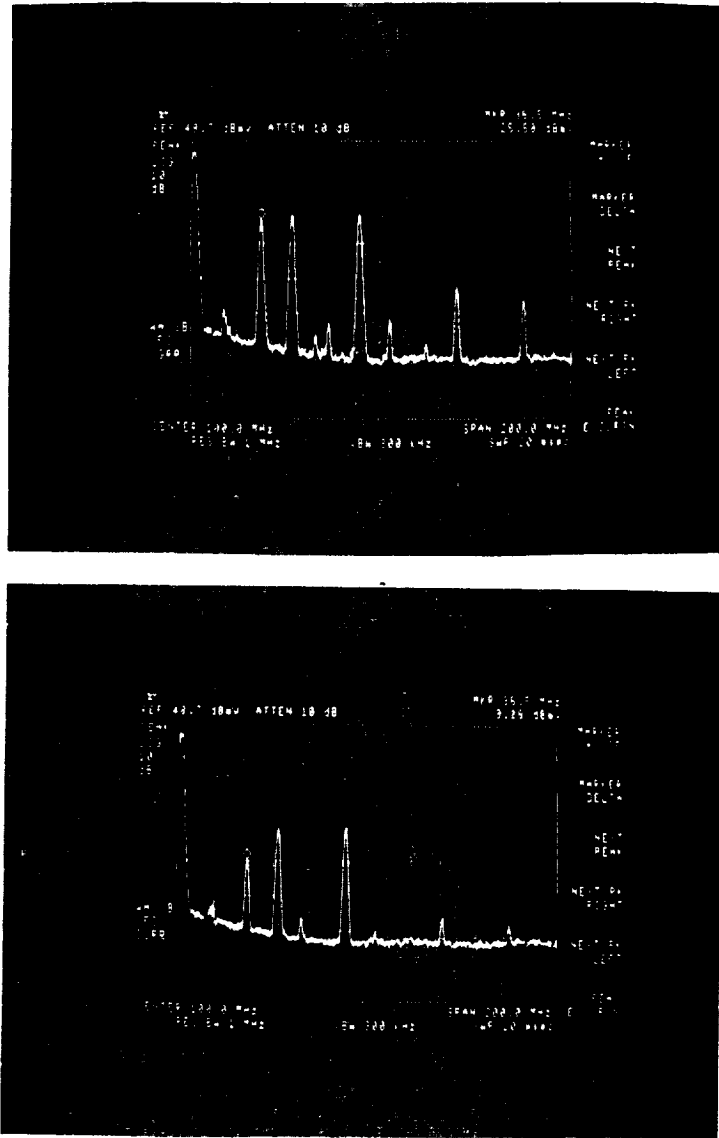
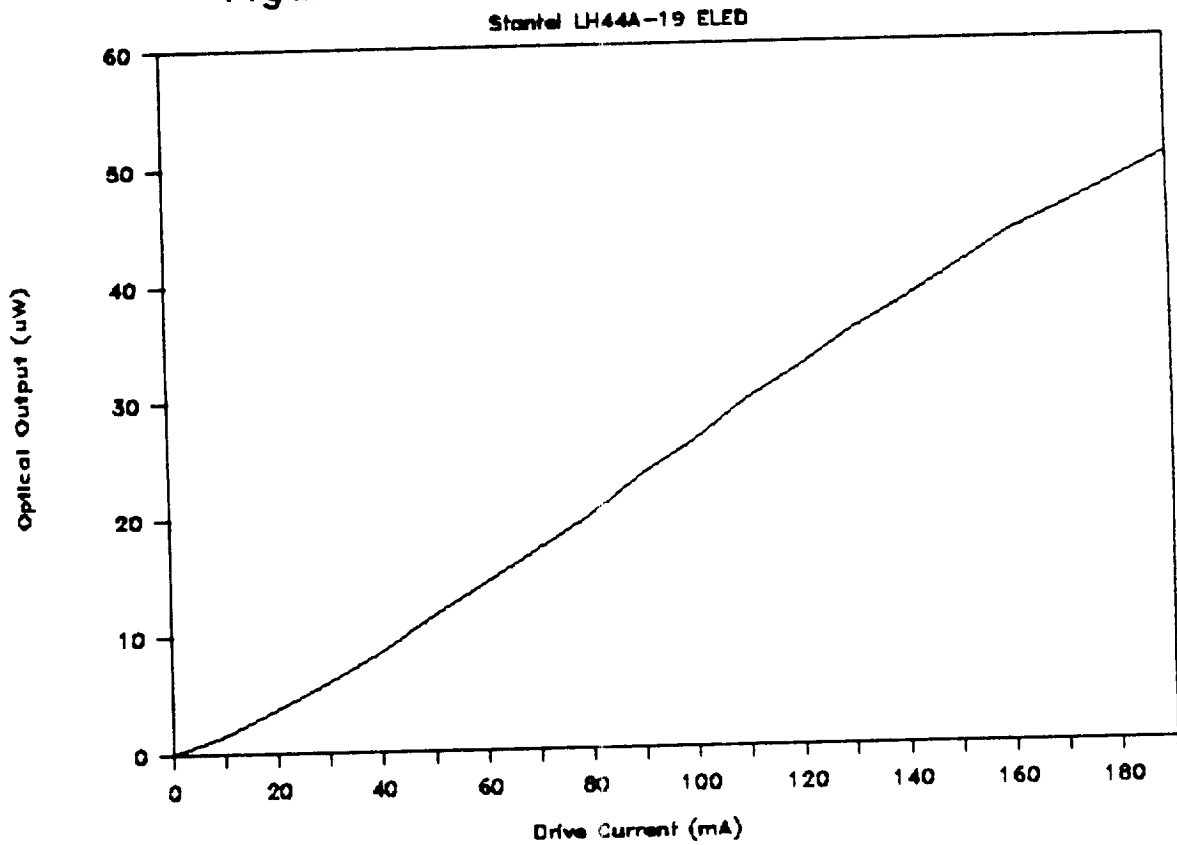

Figure 5-4. Carriers After Transmission  
High modulation depth (top) and low modulation depth (bottom).

It was thus determined that the LED must be significantly nonlinear. The electro-optic characteristic of the LED was measured and is shown in Figure 5-5.

Figure 5-5 LED E-O Characteristic



In the final series of tests, video signals were transmitted through the system depicted in Figure 5-1. Tests were performed with carrier optical modulations of  $m = 0.5$  and  $0.1$ . The unweighted S/N performance of these tests, compared with the theoretical calculations are shown in Figure 5-6.

Figure 5-6 Comparison of FM/FDM

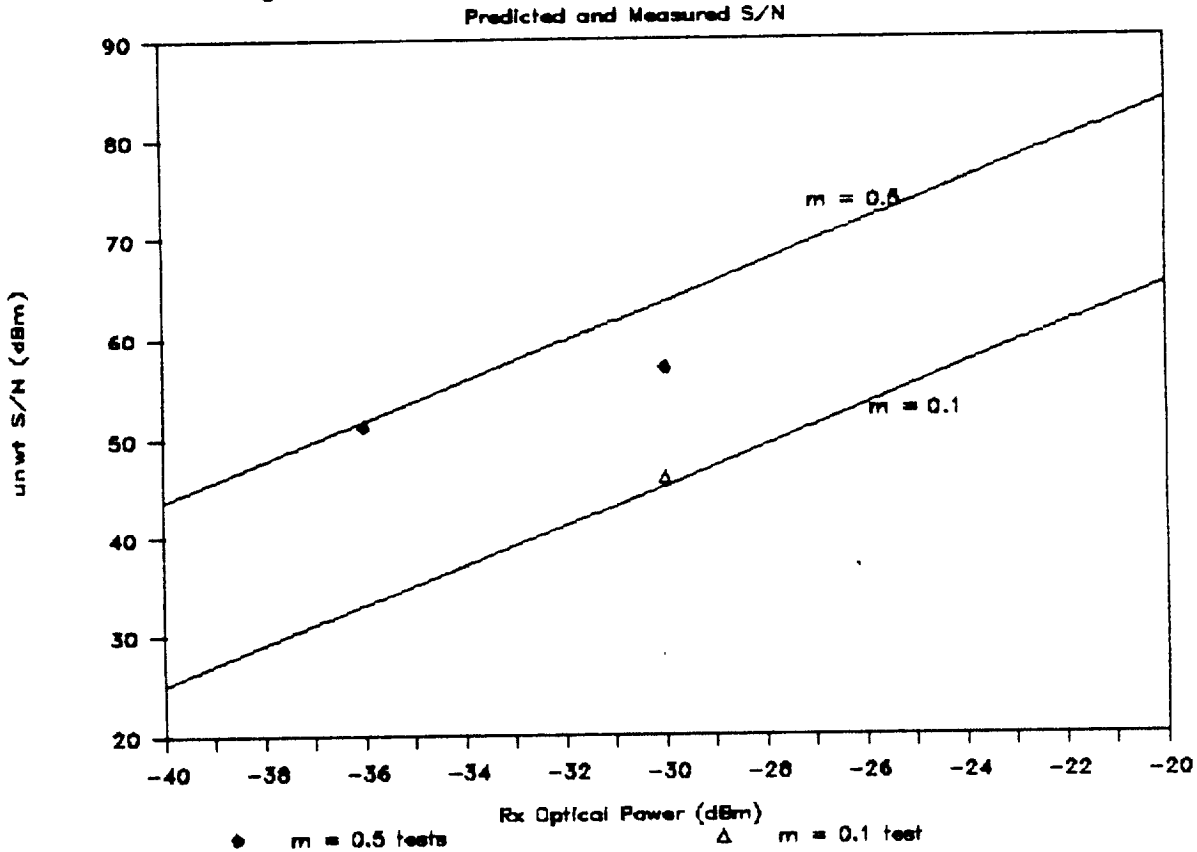

### 5.1.3 SCHEME 1 RESULTS

The tests show that the LED used in the tests was not linear enough to produce entirely acceptable performance when used for the transmission of the complex FM/FDM spectrum. The large frequency difference intermodulation product necessitated a greatly reduced optical modulation depth in order to recover the low-frequency (52.5 MHz) channel. The tests produced good-quality results on the high-frequency (87.5 MHz) channel since it was much less affected by the nonlinearities of the LED.

When low optical modulations were used there was little power margin. However, when the high modulation was used, good performance was measured on the 87.5 MHz signal after 12 dB of optical attenuation. This is encouraging especially since the



tests were performed on a "patchwork" system and time did not permit trying to modify the system for better performance.

This multiplexing scheme appears promising for the transmission of two NTSC video signals. Short-haul quality appears attainable with link losses in excess of 15 dB. However, the actual performance of this scheme depends on using LEDs that are much more linear than those used in the single-channel systems and in the careful choice of FM carrier frequencies and deviations to minimize harmonic and intermodulation distortions.

## 5.2 SCHEME 2: AM / FDM

To accomplish the initial frequency division multiplexing, one baseband signal is SSB modulated to the 12-24 MHz range and is combined with another baseband signal (refer to Figure 4-2). Reserving the desired 12 MHz per channel, this multiplexing would result in a combined signal of 24 MHz minimum bandwidth that would then be wideband frequency modulated. Because of the bandwidth limitations of the fiberoptic link (previously described), the FM carrier should be as low in frequency as possible, say in the range of 50 to 70 MHz. The proposed limit on the bandwidth of the two-video channel fiberoptic links is 100 MHz; so it can be seen that any FM improvement is limited since the peak deviation would have to be less than 24 MHz. In addition, it is not clear that an FM demodulator could be designed that would function acceptably when the carrier is only two or three times the 24 MHz peak deviation.

### 5.2.1 THEORETICAL ANALYSIS

Using the above information, the signal-to-noise performance of a two-channel fiberoptic link was computed for various amounts of power at the receiver. For these calculations, the specifications for the model RTZ-140-80C-MHz PINFET receiver were used, 12-MHz wide video channels were reserved, these signals were assumed to combine at the LED on a voltage basis and the overall optical modulation was set at unity. A 10 dB preemphasis was assumed and the peak deviation was 12 MHz. The results of these calculations are given in Table 5-3.

Table 5-3. Optimum S/N Performance of AM/FDM

power (dBm)	4.2 MHz Baseband	
	C/N (dB)	S/N unwd (dB)
-40	15.9	30.5
-36	23.9	38.5
-30	35.9	50.5
-25	45.9	60.5
-20	55.9	70.5

In order to meet the short-haul S/N specification, an unweighted S/N of approximately 58 dB is necessary. As the table shows, even this optimized system can meet short-haul S/N only if the received optical power is approximately -25 dBm. Assuming reasonable link margins and an output of -16 dBm at the transmitter, the loss budget is very small.

### 5.2.2 LABORATORY TESTS

Laboratory tests were performed on a variation on this AM/FDM scheme. A baseband video channel and the vestigial sideband output of a CATV sub-low band (channel T7) modulator were combined and transmitted using the 12-MHz bandwidth of the existing PCO 5000-series optical transmitters and receivers set to "analog" mode. The existing transmitter used a preemphasis of 4 dB and a peak-to-peak FM deviation of 12 MHz. Figure 5-7 shows the laboratory equipment used to performance the tests and Figure 5-8 shows the Baseband+T7 signal.

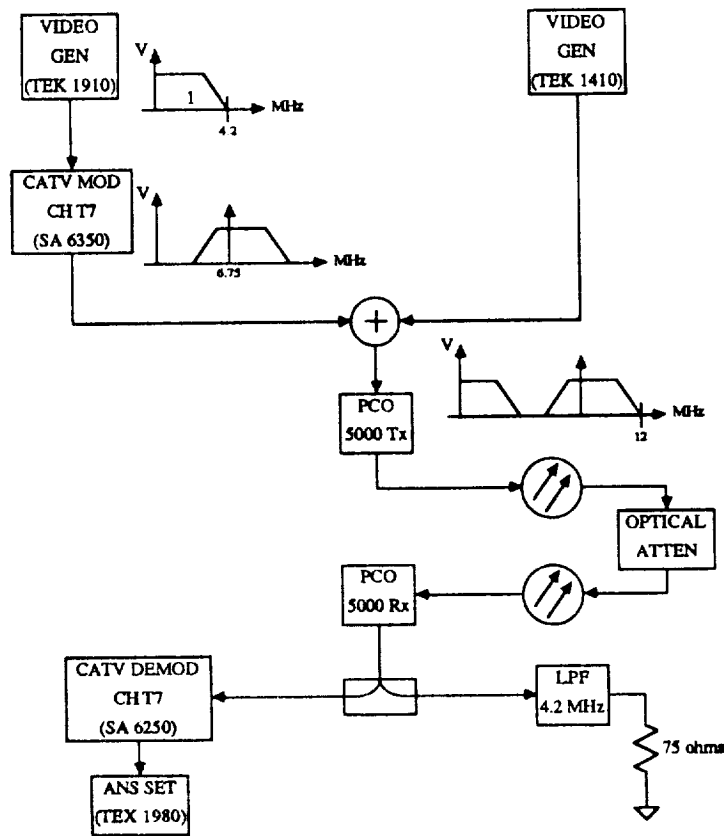

Figure 5-7. Laboratory Tests  
Scheme 2 - AM/FDM

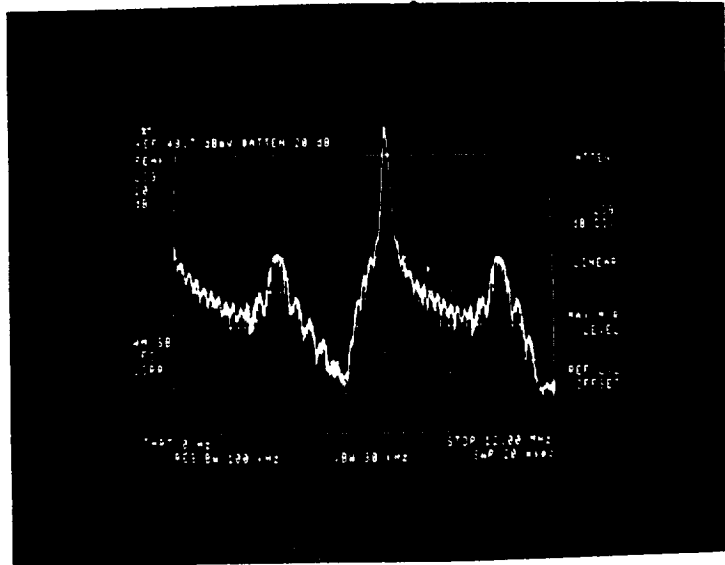
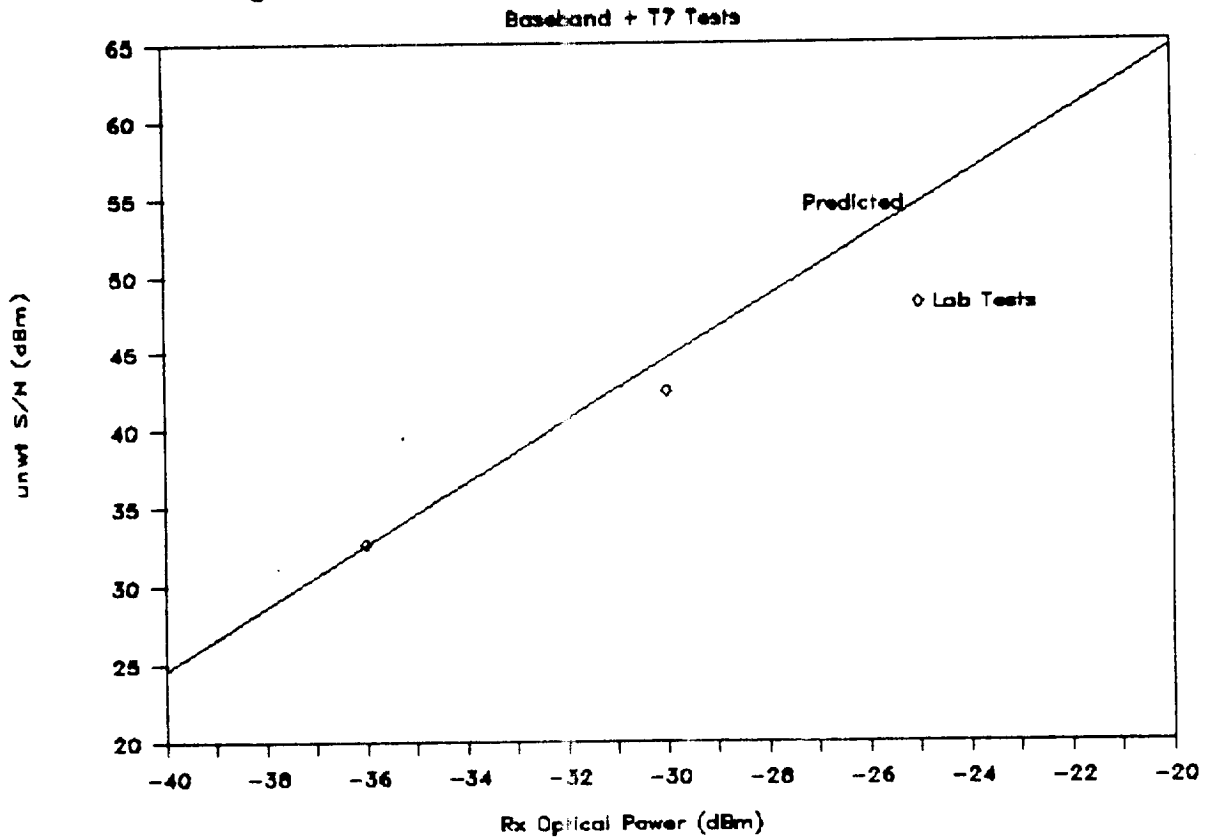

Figure 5-8. Baseband+T7 Signal Used in Laboratory Tests

Due to the transmission of the carrier associated with the T7 signal, the optical modulation depth and the signal level were both necessarily reduced. The results of the performance prediction calculations and of the laboratory tests on this system are shown in Figure 5-9. As can be seen, predicted

Figure 5-9 Performance of AM/FDM



performance of this Baseband+T7 system was worse than the optimum system; and the laboratory measurements agreed well with the performance predictions.

### 5.2.3 SCHEME 2 RESULTS

The theoretical calculations lead to the conclusion that this multiplexing scheme is not likely to produce fiberoptic transmission systems that meet the stringent requirements unless a combination of more powerful sources and wider link bandwidth are used. The laboratory tests verified this conclusion.

## 5.3 SCHEME 3: QAM

### 5.3.1 THEORETICAL ANALYSIS

For this method, two baseband video signals are quadrature amplitude modulated onto a 30-MHz (or so) carrier. Theory states that the two signals can be recovered without cross-talk if the local carrier pair are in exact phase quadrature and if the demodulator carrier pairs are phase-locked precisely to the modulator carriers. These stringent phase requirements result in a practical situation where the crosstalk-to-signal ratio is a very sensitive function of the phase error from actual quadrature<sup>(5)</sup>. The crosstalk-to-signal ratio is given by the equation (6):

$$X/S = 20 \cdot \log(\tan \phi) \quad (6)$$

where: X/S = the crosstalk to signal ratio in dB  
 $\phi$  = the quadrature phase error in degrees

Figure 5-10 shows the relation between crosstalk and phase error. As can be seen, a phase error of 0.05° would result in crosstalk being 60 dB below the signal. However, a 1° phase error would result in crosstalk only 35 dB below the signal.

In the commercial application of quadrature amplitude modulation that is most widely known (C-QUAM broadcast AM stereo) the phase errors are such that there is a signal isolation of 30 dB<sup>(6)</sup>. It remains to be proven if an acceptable isolation can be realized in high-quality video systems.

# Figure 5-10 QAM Phase Sensitivity

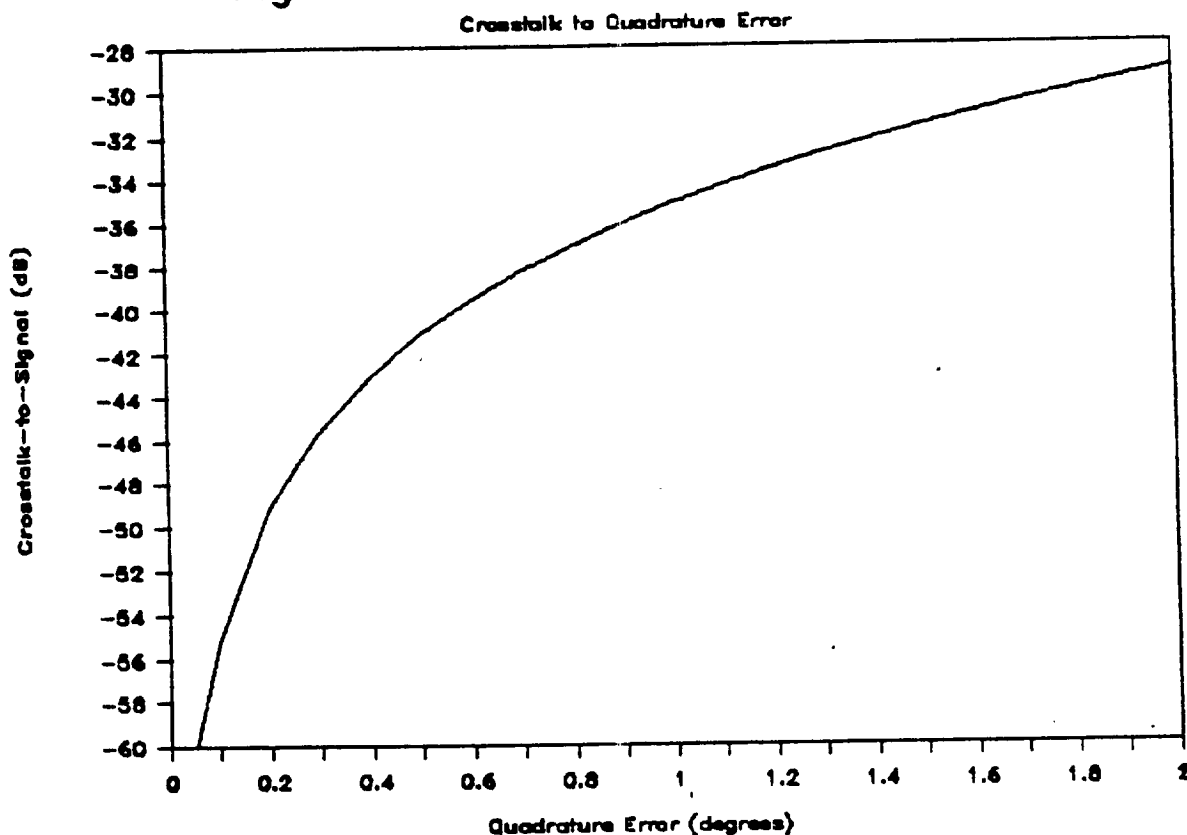

### 5.3.2 LABORATORY TESTS NOT PERFORMED

Time constraints and delays in receiving the necessary electronic parts precluded any laboratory tests of Scheme 3.

### 5.3.3 FURTHER TESTS DESIRABLE

The broad spectrum of the QAM signal, which is the same as double-sideband AM, and the 100-MHz bandwidth of the fiberoptic system would impose the most of the same difficulties and S/N limitations discussed in Sections 5.x and seems to infer that this method is not very promising. However, quadrature amplitude modulation represents novel approach to the multiplexing of two signals onto one fiber. Much less information is available regarding this scheme and no research was found that applied this method to fiberoptic systems. These factors make this method very interesting and suggest that further research, including practical laboratory tests, is desirable.

## SECTION VI

### CONCLUSIONS

#### 6.0 SCHEME 1 IS THE MOST PROMISING

It appears that one of the three electrical multiplexing schemes has a good chance of meeting the difficult goal of transmitting two wideband video signals, on one multimode fiber, across the distances encountered at KSC, meeting RS-250B short-haul standards and doing so relatively inexpensively. It should be possible to produce terminal equipment that meets this goal by employing independent wideband frequency modulation for each of the two baseband video signals, combining the signals using frequency division multiplexing and using this complex signal to intensity modulate a high-performance LED. This most promising method was named Scheme 1 in this report.

Two significant problems were encountered that could prevent the success of Scheme 1. In order to get reasonable transmission distances, it is necessary to impose a large optical modulation depth on a powerful source. This large modulation places stringent requirements on the linearity of the LED. LEDs that are more powerful and more linear than the one used in this study must be employed. Furthermore, the choice of the FM carrier frequencies and deviations are also critical. These parameters must be chosen to reduce harmonic and intermodulation distortions, to limit the multiplexed spectrum (to 100 MHz or so) and to allow reasonable amounts of FM improvement in the signal-to-noise ratio.

#### 6.1 FURTHER STUDIES RECOMMENDED

Additional studies should be undertaken in two areas. Research aimed at defining the current state-of-the-art in LED-based transmitters should be done due to the critical roles that the linearity and power of the LED transmitters play in determining transmission distance and signal distortion. In terms of applied research, these studies would hasten the design of terminal equipment that meets the special need at KSC which led to this project.

Because of its novelty and the lack of information available concerning it, the Quadrature Amplitude Modulation method (Scheme 3) deserves more attention. Even though this preliminary study raises doubts as to the efficacy of this method, it was not possible to verify these doubts nor quantify this method's performance in the laboratory.

## SECTION VII

### ACKNOWLEDGMENTS

The author wishes to acknowledge the special contributions of several people at Kennedy Space Center; for without their assistance and counsel this research would have been far less productive.

Loren Anderson, University of Central Florida, and Dennis Armstrong, NASA, provided noteworthy administrative support for the Summer Faculty Fellowship Program.

Three people made my work in the laboratory both pleasant and productive. Jeffrey Jalowiec and Lee Bowen were understanding, patient and helpful during the past two summers. Robert Swindle provided valuable technical support for this year's work.

Ray Barcklow deserves special mention. He was a tireless source of ideas, a probing questioner, a provider of a wealth of information on vendors and products. Ray even provided the computer upon which this report was written. To Po Huang, thank you for allowing me to use your personal library.

And finally to my principle NASA colleagues: Perry Rogers, Chief, Communications Branch, it has been my pleasure to work within your branch. Larry Hand, Chief, Video and Data Section, thank you for helping me understand the special nature of the communication needs of Kennedy Space Center and for allowing me to make a contribution to your section's work over the past two summers.

It has been my privilege to have known each of you.

## SECTION VIII

### REFERENCES

1. Black, Harold S. Modulation Theory. Van Nostrand, 1962. Pages 225ff.
2. Thomas, John. B. An Introduction to Statistical Communication Theory. Wiley, 1969. Pages 456ff.
3. Sato, K-I et al. "Fiber Optic Analog-Digital Hybrid Signal Transmission Employing Frequency Modulation". IEEE Transactions on Communications. 33:5, May 1985. Page 433ff.
4. Senior, John. Optical Fiber Communications. Prentice-Hall, 1984. Chapter 9.
5. Black, H. S. *ibid.* Pages 176ff.
6. Motorola Databook: "Linear and Interface Integrated Circuits", 1988. Pages 9-84ff.