

# NASA Technical Memorandum 101512

STRUCTURAL OPTIMIZATION OF ROTOR BLADES  
WITH INTEGRATED DYNAMICS AND AERODYNAMICS

Aditi Chattopadhyay and Joanne L. Walsh

(NASA-TN-101512) STRUCTURAL OPTIMIZATION OF  
ROTOR BLADES WITH INTEGRATED DYNAMICS AND  
AERODYNAMICS (NASA) 26 p CSCL 01C

N89-15110

g3/05 Unclass  
0187797

October 1988

**NASA**

National Aeronautics and  
Space Administration

Langley Research Center  
Hampton, Virginia 23665-5225

## INTRODUCTION

The helicopter rotor design process is highly multidisciplinary in nature and requires a merging of several technical disciplines such as dynamics, aerodynamics, structures and acoustics. In the past the conventional design process was controlled by the designer's experience and the use of trial and error methods. Today, one of the more promising approaches to the rotor blade design process is the application of structural optimization techniques. An extensive amount of work has been done in developing design optimization procedures to bring the state of the art to a very high level<sup>1-5</sup>. While these techniques have received wide attention in the fixed-wing field<sup>1</sup>, they are fairly recent in the rotary wing industry<sup>3-5</sup>. Most of the work involving application of optimization techniques to rotor blade design has been focused on nearly independent technical disciplines with very little consideration of the coupling and interaction between the disciplines. For example, the dynamic design requirements have been considered in the optimum rotor blade design in refs. 6-10. Blade aerodynamic and structural requirements were considered in refs. 11 and 12, respectively.

The necessity of merging appropriate disciplines to obtain an integrated design procedure has been recently emerging and with improved understanding of helicopter analyses and optimization schemes, it is now possible to apply optimization techniques and include the couplings between the disciplines. In refs. 13-15 the dynamic and structural design requirements were coupled with airloads in the analysis and in refs. 16 and 17 the dynamic and aeroelastic requirements were integrated. The optimization procedure described in this paper is part of an effort at NASA Langley Research Center<sup>18</sup> and is aimed at integrating two technical disciplines, aerodynamics and dynamics. As a first investigation, the airloads will be included to perform coupled airload/dynamic integration of rotor blades. Later the aerodynamic performance requirements will be added to obtain an integrated aerodynamic/dynamic optimum design procedure. The procedure is no longer sequential - rather it will account for the interactions between the two disciplines simultaneously. The paper briefly describes some of the recent work done by the authors which focussed on optimum blade design with dynamic behavioral constraints and presents some of the authors' recent experiences in developing a strategy for structural optimization with integrated dynamics/aerodynamics of rotor blades.

### INTEGRATED ROTORCRAFT ANALYSIS

Currently at the NASA Langley Research Center, there is an effort to integrate various technical disciplines such as dynamics, aerodynamics and structures into the rotor design process. Shown below in fig. 1 is a tentative plan of the integrated rotor analysis program. The plans are to perform independent discipline level optimizations, (e.g. rotor aerodynamic, dynamic and structural optimization as shown by the clear bubbles) by considering design variables, constraints and objective functions that affect the particular discipline considered. The next step is to couple rotor aerodynamics and dynamics to perform integrated aerodynamic/dynamic optimization. This would involve considerations of design variables and requirements of importance to each discipline, although there are certain design variables that influence all the disciplines involved. The structural design criteria are then introduced to obtain an integrated aerodynamic/dynamic/structural optimization procedure. The influence of airframe dynamics and acoustics will be accounted for through constraints in the design optimization to obtain the 'fully integrated procedure.' The final step is to validate this optimization procedure for a blade test article.

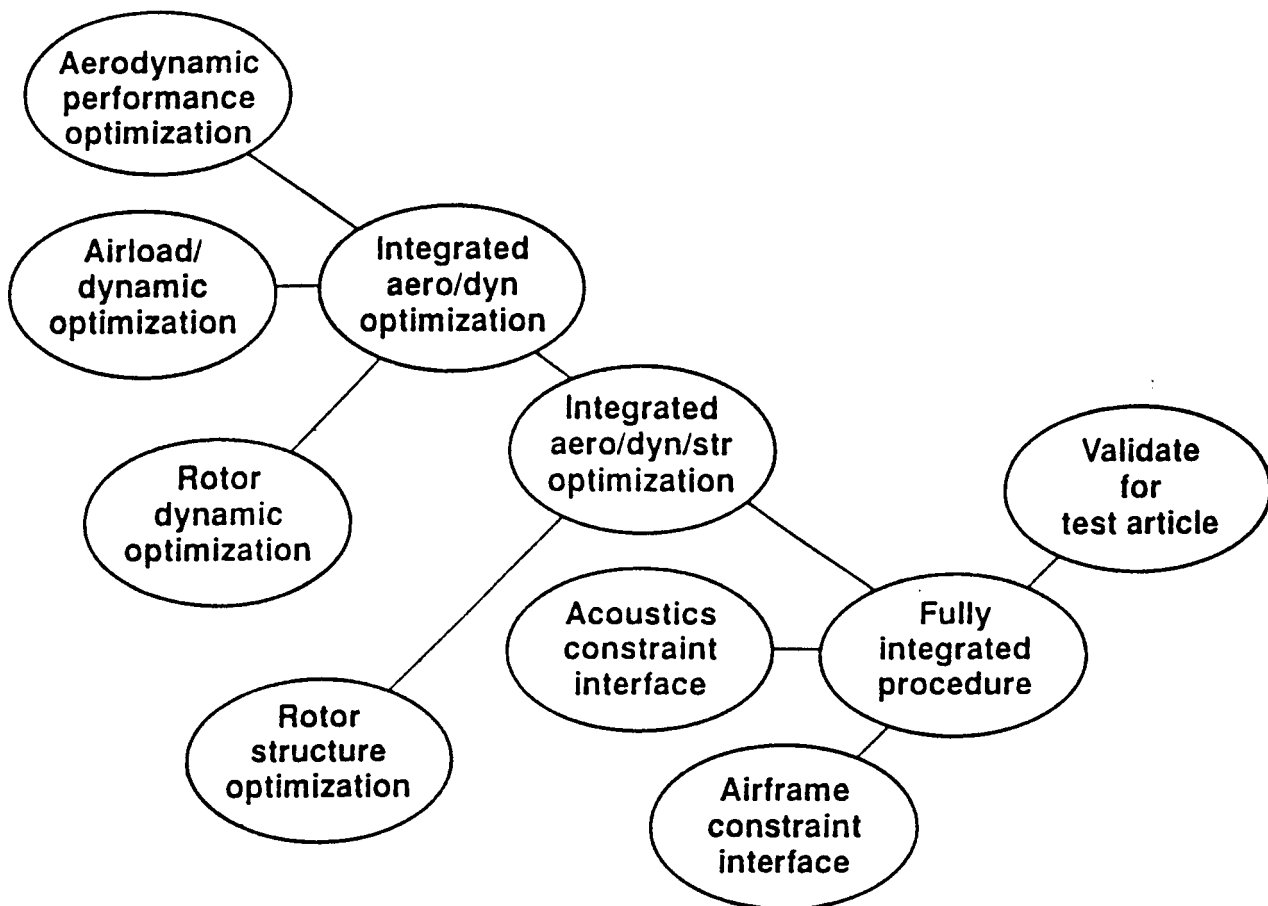

FIGURE 1

### ROTOR BLADE DESIGN CONSIDERATIONS

Rotor blade design involves several considerations some of which are listed below in fig. 2. The blade design must satisfy specified strength criteria and should be damage tolerant. The rotor blade aerodynamic design process consists of proper selection of blade geometric variables such as planform, airfoils, twist, etc. to meet performance requirements<sup>11</sup>. Helicopter performance is usually expressed in terms of horsepower required as a function of velocity. The horsepower required to drive the main rotor for any part of a mission must be less than the available horsepower. The airfoil section stall must also be avoided, i.e. the airfoil sections must operate at section drag coefficients less than a specified value. Two other major criteria in rotor blade design have been low weight and low vibration. For a helicopter in forward flight, the nonuniform flow passing through the rotor causes oscillating airloads on the rotor blades. These loads in turn are translated into vibratory shear forces and bending moments at the hub. Therefore, vibration alleviation without weight penalty is an important criterion. The blade should also be aeroelastically stable<sup>17,19</sup> and finally the noise levels generated by the rotor which are a function of local Mach number and airloads should be reduced. This paper will concentrate on the low vibration and the low blade weight aspects of the design.

- Strength, survivability, fatigue life
- Aerodynamic performance
- Vibration
- Weight
- Aeroelastic stability
- Acoustics

FIGURE 2

As mentioned before, low vibration is an important design requirement in helicopter rotor blade design. One way of reducing the vibration level in the blade is to design the blade such that the natural frequencies are separated from multiples of the driving frequencies. Failure to consider frequency placement early in the design process can cause a significant increase in the final blade weight later if postdesign addition of nonstructural masses is required. Appropriately placing the natural frequencies can be done by a proper tailoring of the blade mass and/or stiffness distributions to meet the necessary design requirements using structural optimization. This section of the paper presents an overview of the dynamic optimization work which has been completed. The goal of the dynamic optimization problem (fig. 3) is to obtain minimum weight designs of blades with constraints on multiple coupled flap-lag natural frequencies. It is also important that the autorotational performance of the blade not be degraded during the tailoring process since the blade should have sufficient inertia to autorotate in case of an engine failure. In order to ensure a safe design, the blade centrifugal stress should be limited by an appropriate upper bound. For this study only centrifugal stress has been considered. The blade is assumed to be in vacuum in this investigation and the results of this analysis will generate a good starting point for the integrated optimization.

- **Goal - Minimize blade weight with constraints on multiple coupled natural frequencies, autorotational inertia and stress**
- **Approach - Stiffness and/or mass modifications, placement of tuning masses**
- **Assumption - Blade is in vacuum - generates good starting point for integrated optimization**

FIGURE 3

ROTOR BLADE MODEL FOR DYNAMIC OPTIMIZATION

The rotor blade model for dynamic optimization is shown below in fig. 4. The blade is articulated and has a fixed hub, a pretwist and a root spring which allows torsional motion. A box beam with unequal vertical wall thicknesses is located inside the airfoil and lumped nonstructural masses are located inside the box and distributed spanwise. This model is based on an existing blade design denoted the 'reference blade' described in refs. 8, 9, and 13. As in ref. 13, it is assumed that the box beam contributes all the blade stiffness, that is, the contributions of the skin, honeycomb, etc. to the blade flap and lag stiffnesses are neglected. The details for calculating the box beam section properties can be found in ref. 8. The properties of the box beam located inside the airfoil are as follows:  $h=0.117$  ft,  $b=0.463$  ft,  $\rho=8.645$  slugs/ft<sup>3</sup>,  $E=2.304 \times 10^9$  lb/ft<sup>2</sup>, allowable stress  $\sigma_{\max}=1.93 \times 10^7$  lb/ft<sup>2</sup> and factor of safety,  $FS=3$ . The blade is discretized into ten segments. Both rectangular and tapered blades are considered. For the rectangular blade, the box beam outer dimensions along the blade span remain unchanged. The design variables for the rectangular blade are the box beam wall thicknesses  $t_1$ ,  $t_2$ , and  $t_3$  and the magnitudes of the nonstructural weights located inside the box beam at ten spanwise locations. For the tapered blade it is assumed, as in refs. 8 and 9 that the box beam is tapered and the additional design variables are the box beam height at the root,  $h_r$ , and the taper ratio,  $\lambda_h$ , which is defined as the ratio of the box beam height at the root to the corresponding value at the tip. A linear variation of the box beam height,  $h$ , in the spanwise direction is assumed.

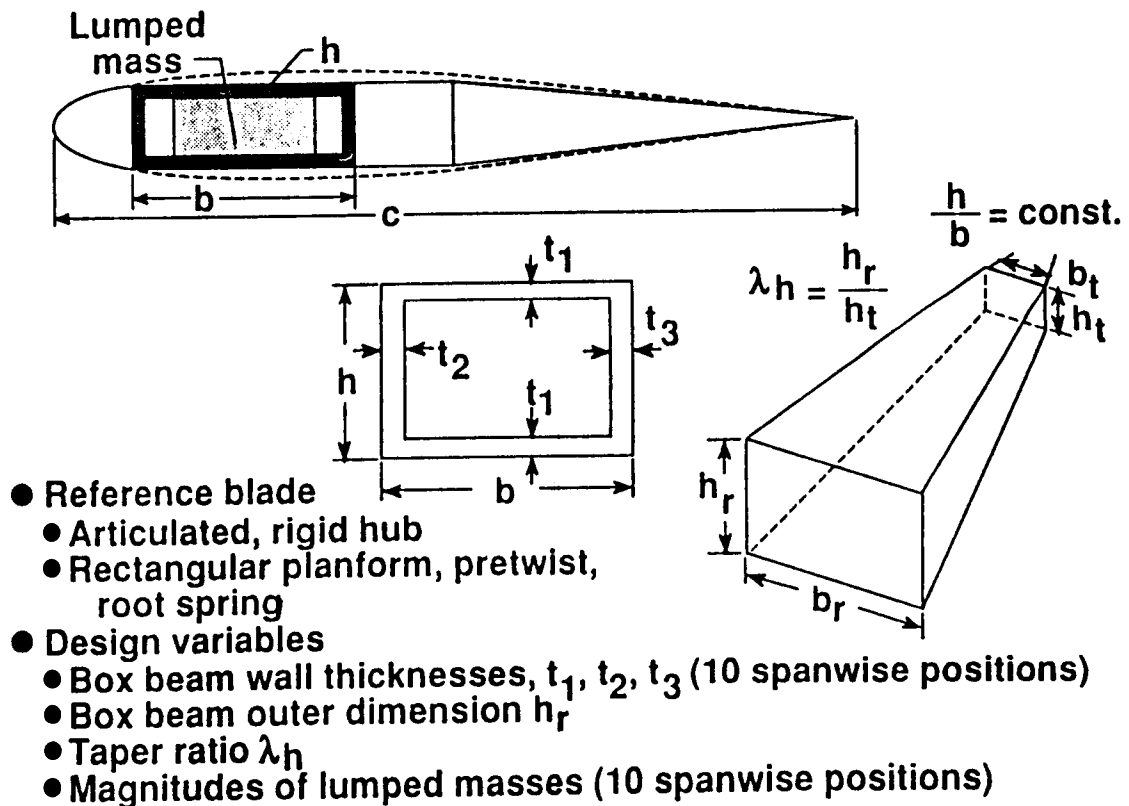

FIGURE 4

The purpose of the optimization procedure, as described in fig. 5 below, is to minimize the weight  $W$  of the rotor blade while constraining the natural frequencies  $f_k$  to be within specified 'windows' (upper and lower bounds).

An existing blade which is being used in a production helicopter has been selected as a baseline blade and will be referred to as the 'reference blade'. A modal analysis of the reference blade showed that the frequencies of interest were not near the  $n$  per rev (critical values) values where  $n$  denotes the total number of blades. Hence it was decided to define constraints to force the frequencies of the optimum blade to be close to those of the reference blade. The concept of 'windows' has been used since the nonlinear programming method used in this work cannot handle equality constraints. These windows, denoted by  $f_{k_L}$  and  $f_{k_U}$  (for the lower bound and

upper bound on frequency, respectively), are on the frequencies of the first three lead-lag dominated modes and the first two flapping dominated modes (elastic modes only). The frequency windows are carefully selected to alleviate any shear amplification problem. A prescribed lower limit  $\alpha$  on the blade autorotational inertia  $AI$  and an upper bound  $\sigma_{max}$  on the blade centrifugal stress  $\sigma_k$  have also been used. Side constraints  $\phi_{i_L}$  and  $\phi_{i_U}$

(lower and upper bounds on the  $i^{th}$  design variable  $\phi_i$ ) have been imposed on the design variables to avoid impractical solutions.

- Objective function

- Minimum blade weight  $W$

$$W = W_b + W_o$$

- Constraints

- Frequency windows on first 3 lead-lag and first 2 flapping elastic modes

$$f_{k_L} \leq f_k \leq f_{k_U} \quad k = 1, 2, 3, 4, 5$$

- Lower bound on autorotational inertia

$$AI \geq \alpha$$

- Upper bound on centrifugal stress

$$\sigma_k \cdot FS \leq \sigma_{max}$$

- Bounds on design variables

$$\phi_{i_L} \leq \phi_i \leq \phi_{i_U}$$

FIGURE 5

## METHODOLOGY FOR DYNAMIC OPTIMIZATION PROBLEM

The procedure described in this paper uses the program Comprehensive Analytical Model of Rotorcraft Aerodynamics and Dynamics (CAMRAD)<sup>20</sup>. The modal analysis portion of the program CAMRAD which uses a modified Galerkin approach<sup>21</sup> has been used for the dynamic optimization problem. According to ref. 22, this approach is the preferred method for computing mode shapes and frequencies of structures having large radial variations in bending stiffness. The general purpose optimization program CONMIN<sup>23</sup> which uses the nonlinear programming method of feasible directions has been used for the optimization. The method of solution described below (fig. 6) starts with discretizing the blade into finite segments. In the search for the optimum vector of new design variables, CONMIN requires derivatives of the objective function and constraints. The user has the option of either allowing CONMIN to calculate derivatives by using forward differences, or by supplying those derivatives to CONMIN. In the work presented in this paper, the latter approach has been used. Analytical expressions for the derivatives of the objective function and the autorotational inertia constraint have been obtained. A central difference scheme has been used for the derivatives of the frequency constraints. The initial attempt<sup>8,9</sup> using forward differences gave highly inaccurate derivatives.

The optimization process generally requires many evaluations of the objective function and the constraints before an optimum design is obtained. The process therefore can be very expensive if exact analyses are made for each evaluation. To reduce computational requirements, the optimization is based on the use of approximate analyses. In the present paper a piecewise linear analysis, based on first order Taylor Series expansions, is used. The approximate analyses should produce accurate characteristics of the real problem in a neighborhood of the current design which is continuously updated during optimization. The method has been found to be effective in the past (e.g., ref. 24) for providing accurate approximations.

- Codes used
  - CAMRAD - Blade modal analysis (modified Galerkin approach)
  - CONMIN - Optimization (nonlinear programming approach - method of feasible directions)
- Method of solution
  - Discretize the blade (10 finite segments)
  - Compute mode shapes and frequencies
  - Perform sensitivity analysis
    - Analytical derivatives of objective function, autorotational inertia constraint and stress constraints
    - Central differences for frequency constraint derivatives
- Use approximate analysis techniques

FIGURE 6



**DYNAMIC OPTIMIZATION RESULTS FOR RECTANGULAR AND TAPERED BLADES**

Results obtained by applying the dynamic optimization procedure to the design of both rectangular and tapered rotor blades are summarized here (fig. 7). The table below depicts some of the representative results for the rectangular and tapered blades. For the rectangular blade the 40 design variables are the box beam wall thicknesses ( $t_1, t_2, t_3$ ) and the magnitudes of the nonstructural masses at ten spanwise locations. For the tapered blade with 42 design variables, the two additional design variables are the box beam height at the root and the taper ratio. In each table, column 1 represents the reference blade data; column 2 gives the corresponding information for the optimum design for the rectangular blade with constraints on the five frequencies, autorotational inertia and stress; and column 3 gives results for the optimum design for the tapered blade with the same set of constraints. In all cases convergence to optimum designs typically has been achieved in 8-10 cycles.

The table indicates that the optimum rectangular blade is 4.7 percent lighter than the reference blade and the optimum tapered blade is 6.2 percent lighter than the reference blade. Although the first lead-lag frequency ( $f_1$ ) is at its prescribed upper bound after optimization, both frequencies are satisfactory as far as the shear amplification problem is concerned. The autorotational inertia constraint is also active (i.e. exactly satisfied) in all the cases.

	Reference blade	Optimum blade	
		Rectangular (40 design variables)	Tapered (42 design variables)
$\lambda h$	1.0	1.0	1.49
$f_1, \text{ Hz}$	12.285	12.408*	12.408*
$f_2, \text{ Hz}$	16.098	16.075	16.066
$f_3, \text{ Hz}$	20.913	21.081	20.888
$f_4, \text{ Hz}$	34.624	34.823	34.678
$f_5, \text{ Hz}$	35.861	35.800	35.507
Autorotational inertia(AI), lb-ft <sup>2</sup>	517.3*	517.3*	517.3*
Blade weight, lb	98.27	93.61	92.16
Percent reduction in blade weight !	----	4.74	6.21

! From reference blade

\* Active

FIGURE 7

OPTIMUM HORIZONTAL WALL THICKNESS ( $t_1$ ) DISTRIBUTIONS  
WITH MULTIPLE FREQUENCY AND STRESS CONSTRAINTS

The optimum box beam horizontal wall thickness ( $t_1$ ) distributions along the blade span are shown below in fig. 8 and are compared with the corresponding distribution of the reference blade. On the left, the optimum distribution corresponds to the rectangular blade with 40 design variables (column 2, fig. 7). On the right, the optimum distribution corresponds to the tapered blade with 42 design variables (column 3, fig. 7). In both cases the optimum blade has a larger value of  $t_1$  than the reference blade at the blade tip. The explanation for this is as follows. The autorotational inertia can be increased with an increase in the moment arm and, therefore, the constraint on the autorotational inertia is satisfied easily if more mass is moved to the blade tip. However, the presence of the centrifugal stress constraint counteracts this tendency. Therefore, the net result is more blade mass towards the outboard region of the blade (although, not necessarily all at the tip).

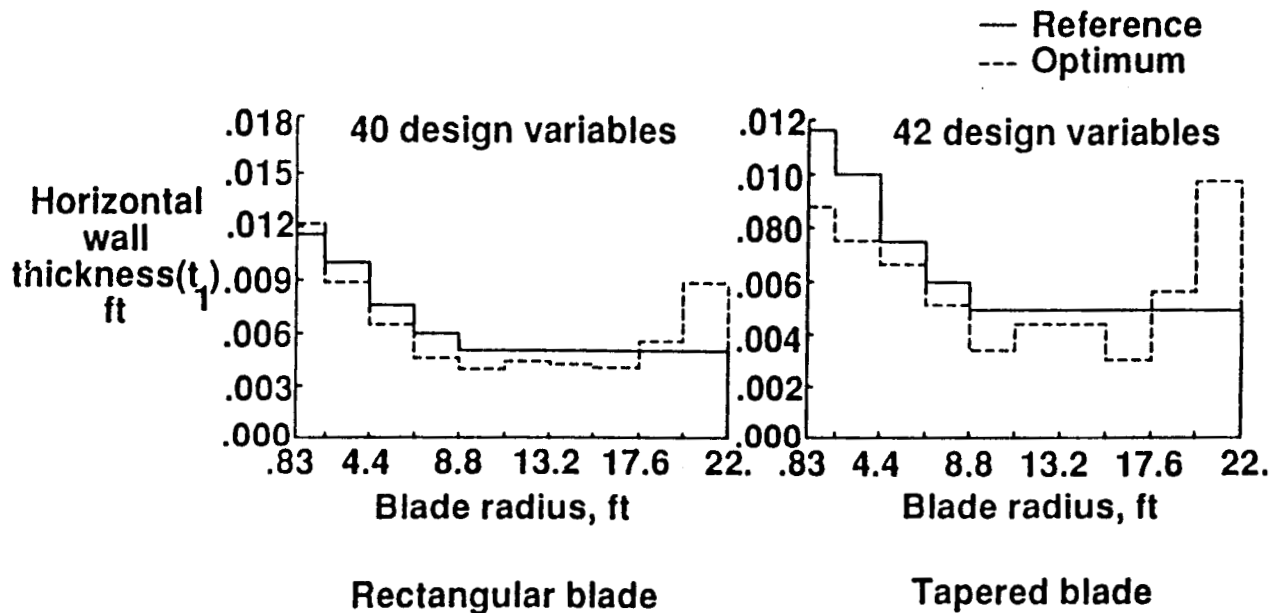

FIGURE 8

**OPTIMUM VERTICAL WALL THICKNESS ( $t_2$ ) DISTRIBUTIONS  
WITH MULTIPLE FREQUENCY AND STRESS CONSTRAINTS**

The optimum box beam vertical wall thickness ( $t_2$ ) distributions along the blade span are shown below in fig. 9 and are compared with the corresponding distribution of the reference blade. On the left, the optimum distribution corresponds to the rectangular blade with 40 design variables (column 2, fig. 7). On the right, the optimum distribution corresponds to the tapered blade with 42 design variables (column 3, fig. 7). In both cases the optimum blade has a larger value of  $t_2$  than the reference blade at the blade tip due to the presence of the autorotational inertial constraint as explained in the previous chart. However, the difference in magnitude between the optimum and reference blade value at the blade tip is not as significant as it is for the horizontal wall thickness  $t_1$ . The nature of the horizontal and vertical wall thicknesses ( $t_1$  and  $t_2$ , respectively) are also different as the former primarily affects the flapping frequency and the later affects the lead-lag frequency.

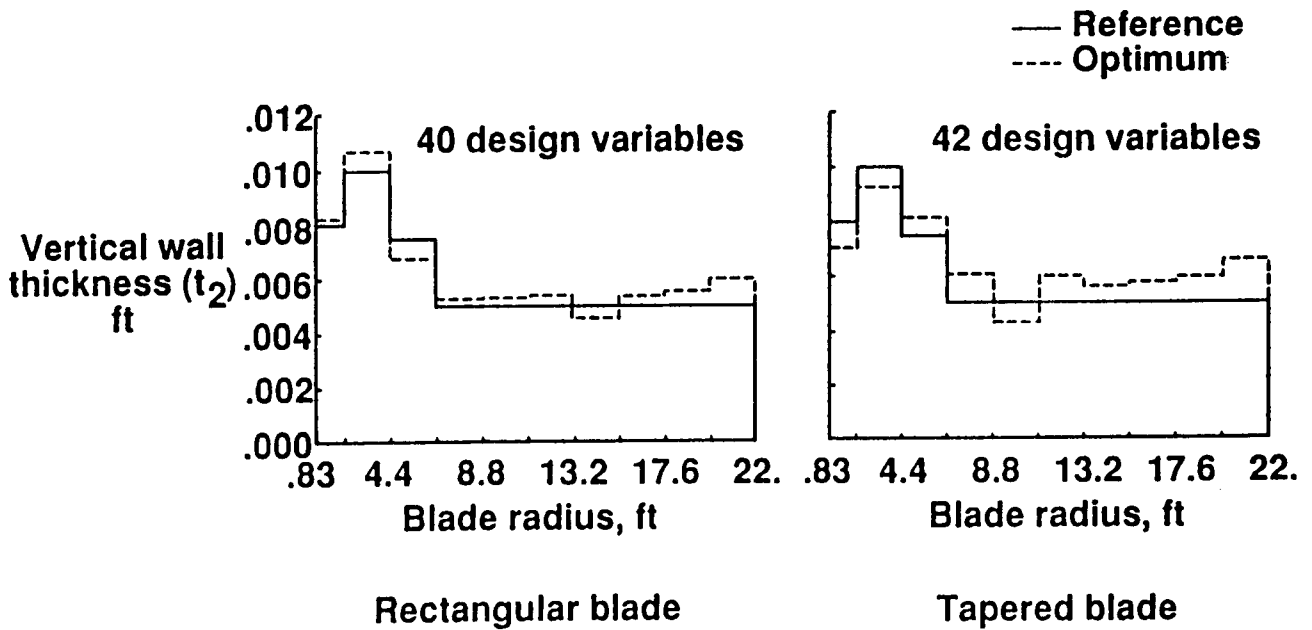

FIGURE 9

**OPTIMUM NONSTRUCTURAL SEGMENT WEIGHT DISTRIBUTIONS  
WITH MULTIPLE FREQUENCY AND STRESS CONSTRAINTS**

Shown below (fig. 10) are the optimum and the reference blade nonstructural segment weight distributions along the blade radius for both the rectangular blade with 40 design variables (column 2, fig. 7) and the tapered blade with 42 design variables (column 3, fig. 7). For the rectangular blade (left side of the figure) the optimum blade has lower nonstructural weight throughout the blade span. However, for the tapered blade (right side of the figure) the optimum blade has larger nonstructural weight towards the blade tip than the reference blade. This is because the tapered blade has reduced structural weight requirements at the blade tip. Hence, in order to satisfy the autorotational inertia constraint, the nonstructural weight at the tip must increase. Even so the total weight of the optimum blade is still lower than that of the reference blade.

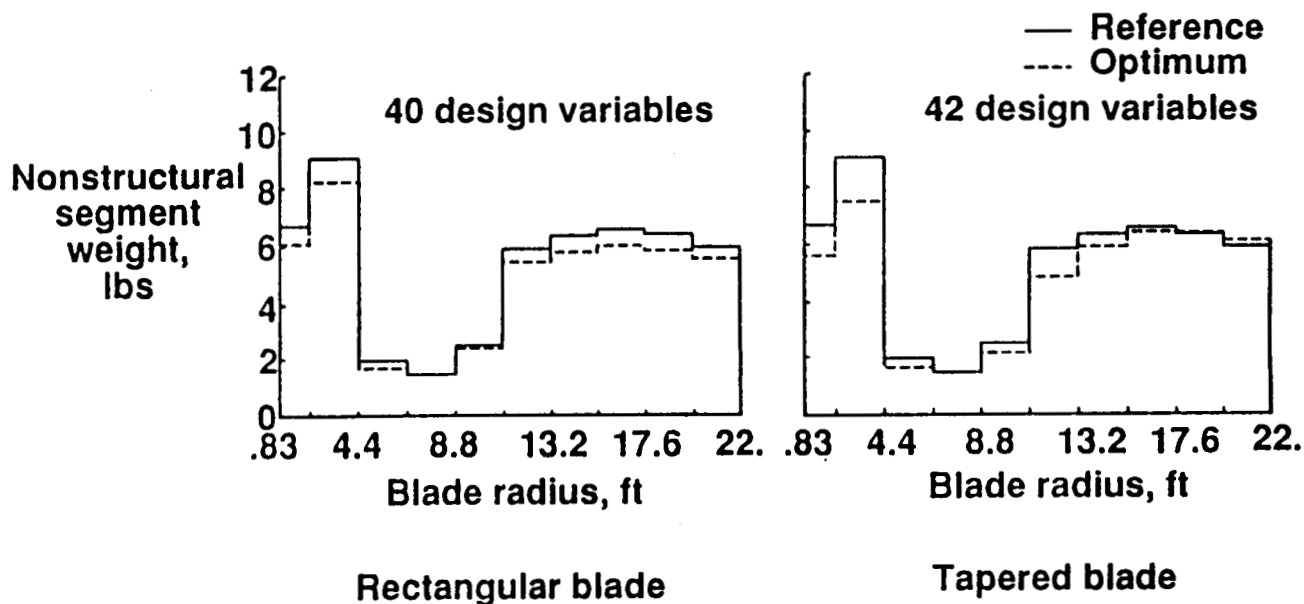

FIGURE 10

## STRATEGY AND TASKS FOR STRUCTURAL OPTIMIZATION WITH INTEGRATED DYNAMICS/AERODYNAMICS

The structural optimization of helicopter rotor blades with integrated dynamics/aerodynamics involves both dynamic, aerodynamic and structural design variables, constraints and objective functions along with the blade dynamic/aerodynamic/structural analysis. Together with calculations of the associated sensitivity derivatives this can make the integrated optimization process very complicated and expensive. As a first step towards integrating dynamics and aerodynamics, it was decided to separate the aerodynamic effects into two parts: airloads and performance (fig. 11). The initial step in integrated dynamic/aerodynamic optimization will combine airloads and dynamics. The second step would involve addition of aerodynamic performance to obtain a fully integrated structural optimization procedure with dynamics/aerodynamics. The inclusion of airloads would allow calculation of hub shears and moments which enter into the objective function and/or constraints. This would allow the inclusion of blade aeroelasticity through either limits on the hub loads or the blade stability margin. The aerodynamic analysis would include trimming of the blade at each step of the design process for a specified flight condition. The trim analysis is in fact a coupled dynamic/aerodynamic/structural procedure.

The integrated design process would require the use of more than one objective function in the design formulation. This is because it is difficult to single out an objective function as the primary requirement in an engineering system as complex as the rotor blade. This leads to the necessity of using multiple objective function techniques to formulate the optimization problem. Therefore, various multiple objective function techniques are being investigated and a method called 'Global Criteria Approach'<sup>25</sup> is being examined.

- Dynamic/aerodynamic/structural design variables and constraints
- Include airloads first - integrated dynamic/airload optimization procedure
- Add aerodynamic performance next - fully integrated dynamic/aerodynamic optimization procedure
- Coupled trim analysis
- Several objective functions - multiple objective function handling capability required
- Evaluate 'Global Criteria' approach for multiple objective optimization

FIGURE 11

**ANALYSIS COUPLINGS FOR STRUCTURAL OPTIMIZATION  
WITH INTEGRATED DYNAMICS/AIRLOADS**

Below is a schematic diagram that shows the general flow of information between the three major analyses involved in integrated airloads/dynamic optimization. Note that the three major disciplines are internally coupled. For instance, the blade aerodynamic analysis provides the airloads and control settings which are fed into the blade dynamic analysis. The blade dynamic analysis, based on this information, provides the blade natural frequencies, mode shapes, hub shears, moments, etc. If unsteady aerodynamics is included, the dynamic and aerodynamic analyses are coupled as shown by the dotted line in fig. 12 below. The information obtained from the dynamic analysis (shears/bending moments) are fed into the structural analysis box along with the airloads from the aerodynamic analysis to perform the trim analysis. The structural analysis is also used to compute the blade centrifugal stresses which are incorporated as constraints in the optimization process.

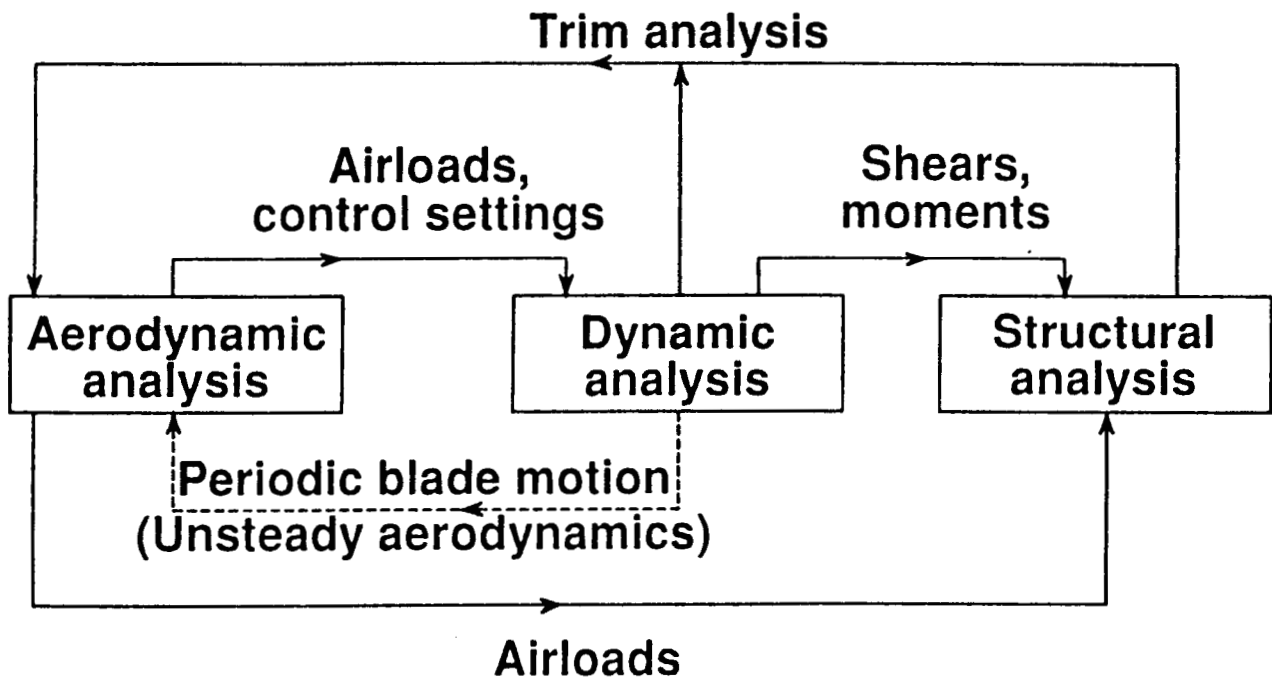

FIGURE 12

**COMPUTATIONAL CONSIDERATIONS FOR STRUCTURAL OPTIMIZATION  
WITH INTEGRATED DYNAMICS/AIRLOADS USING CAMRAD**

Some of the computational considerations involved in the structural optimization procedure with integrated dynamics/airloads is described below in fig. 13. The program CAMRAD<sup>20</sup> is used for the aerodynamic and dynamic analyses of the rotor blade in forward flight. The program has been found to be very reliable for analysis of helicopter rotors<sup>8,9,26</sup>. It uses a lifting line or blade element approach to calculate the section loading from the airfoil two-dimensional aerodynamic characteristics with corrections for yawed and three-dimensional flow effects<sup>22</sup>. The program also has the provision for including unsteady aerodynamics.

Each intermediate design should satisfy the trim condition. The program CAMRAD offers two broad categories of trimming - the free flight case and the wind tunnel case. In the free flight case, the entire helicopter is trimmed to force and moment equilibrium whereas in the wind tunnel case the isolated rotor is trimmed to a prescribed operating condition. It is possible to use a free flight trim option for an isolated rotor in a wind tunnel since the trim option and the degrees of freedom representing the aircraft can be specified independently. However, the wind tunnel trimming options are more typical of a rotor in a wind tunnel without consideration of the complete rotorcraft. The wind tunnel trim option is selected for this analysis since the model used in this study is a wind tunnel model of a rotor. The trim option consists of trimming the rotor lift, drag and flapping angle with collective pitch, cyclic pitch and shaft angle.

- **Aerodynamic loads (forward flight)**
  - **Lifting line theory to calculate section loading from airfoil 2-D aerodynamic characteristics**
  - **Corrections for yawed and 3-D flow effects**
- **Trim analysis**
  - **Wind tunnel trim for isolated rotor**
    - **Lift, drag and flapping angle with collective pitch, cyclic pitch and shaft angle**

FIGURE 13

**FORMULATION OF THE STRUCTURAL OPTIMIZATION PROBLEM  
WITH INTEGRATED DYNAMICS/AIRLOADS**

The optimization problem addressed here uses blade weight and blade root 4 per rev vertical shear as the objective functions to be minimized. The constraints are 'windows' on the coupled flap-lag natural frequencies to prevent them from falling into the critical ranges, a prescribed lower bound on the blade autorotational inertia and a maximum allowable upper bound on the blade stress. The design variables (fig. 14) are the blade spanwise stiffness distributions (EI's and GJ), the magnitudes of the lumped nonstructural masses distributed spanwise, the blade taper ratio and the root chord as shown below in the figure. The nonstructural masses which were used for frequency placement in the dynamics work discussed earlier will now be used for both frequency tuning as well as hub shear alleviation.

- Objective function: Blade weight and blade root vertical shear
- Constraints: Frequencies, autorotational inertia, blade stress
- Design variables: Stiffness and mass distributions, magnitudes of lumped/tuning masses, taper ratio, root chord

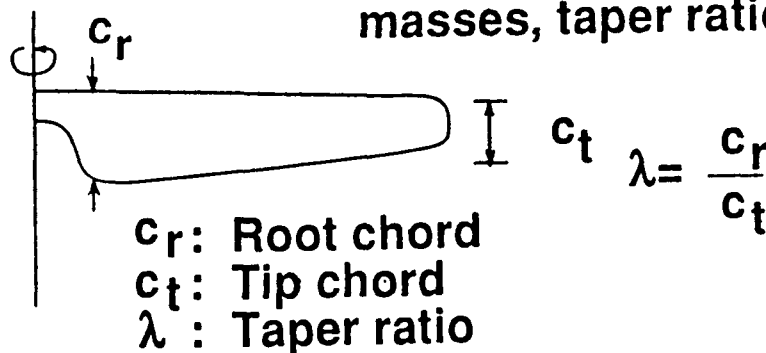

FIGURE 14



**FLOWCHART OF THE STRUCTURAL OPTIMIZATION PROCEDURE  
WITH INTEGRATED DYNAMICS/AIRLOADS**

The optimization procedure shown in the flowchart below (fig. 15) is initiated by identifying the blade preassigned parameters which are the parameters that are held fixed during optimization. The next step is to initialize the design variables and perform the internally coupled blade analysis which comprises blade aerodynamic, dynamic and structural analyses. A sensitivity analysis is part of the procedure and consists of evaluations of the derivatives of the objective function and the constraints with respect to the independent design variables. Once the sensitivity analysis is performed the approximate model is defined based on a standard approximation technique. Using CONMIN along with the approximate model updated design variable values are obtained. The process continues until convergence is achieved.

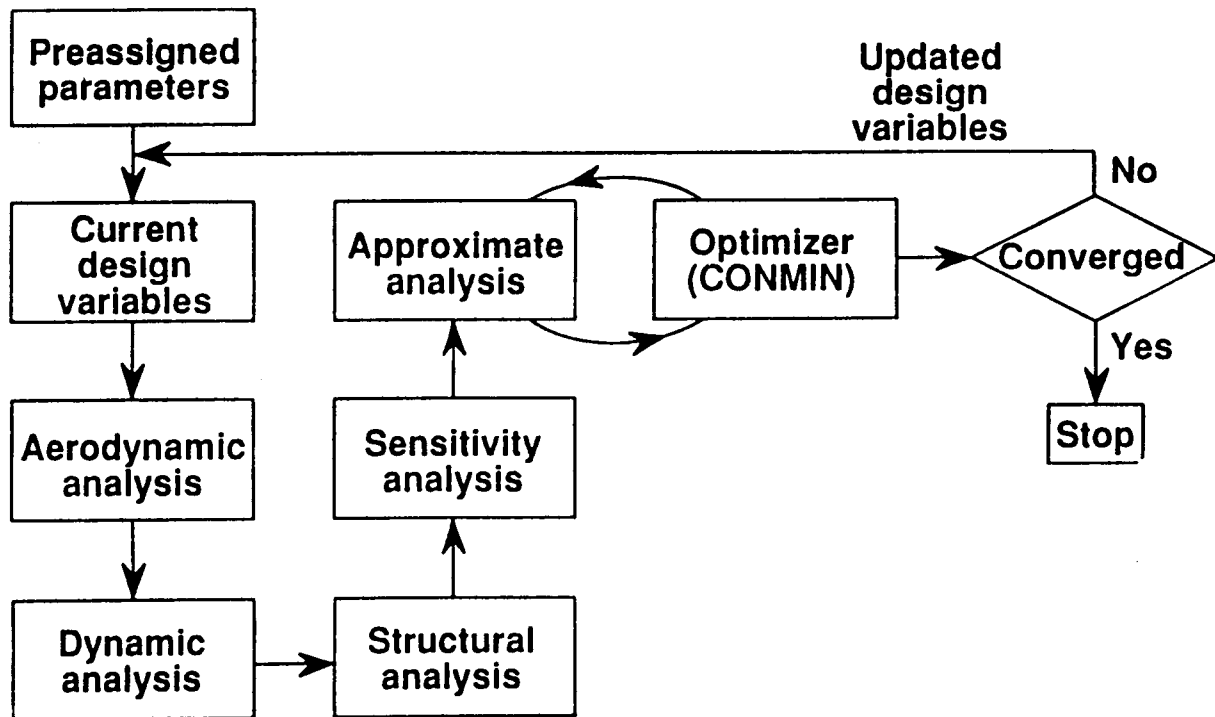

FIGURE 15

## SENSITIVITY ANALYSIS

The conventional approach for performing sensitivity analysis is to calculate the derivatives either analytically or by using finite difference schemes. Since analytical expressions are seldom available and use of finite difference schemes is usually expensive and sometimes inaccurate, a new method<sup>27</sup> for obtaining the system sensitivity has been considered for the present work. The method enables one to calculate the sensitivity derivatives of the system solution with respect to a design variable from a set of simultaneous equations which are known as Global Sensitivity Equations (GSE). In fig. 16 the system sensitivity equations are described in terms of a coupled system consisting of the boxes A, D, and S representing aerodynamics, dynamics and structures. Each discipline box is regarded as a set of mathematical operations that solves one of the sets of governing equations on the right to produce an output denoted by Y. For example,  $Y_A$  denotes the output of the aerodynamic analysis. The coupling of the system is demonstrated in the figure below. The design variables are denoted by X. The quantities X and Y are in general vectors. Furthermore the subset of  $Y_A$  entering D may be different from the subset of  $Y_A$  entering S, although the subsets may overlap.

Using chain rule on the governing equations as in ref. 27, the system sensitivity equations are derived. The sensitivity derivatives appear as the vector of unknowns. The coefficient matrix consists of partial derivatives of the output of the various disciplinary responses with respect to each other positioned off the diagonal and identity submatrices along the diagonal. Nonzero values of these partial derivatives reflect system couplings. The right hand side vector contains the partial derivatives of the disciplinary outputs with respect to a particular design variable (e.g.  $X_k$ ). The coefficient matrix needs only to be formed and factored once for a given system and then back substituted using a new right hand side vector for every new design variable. Thus the method enables the computations of derivatives of complex internally coupled systems without having to perform expensive finite difference derivatives based on the entire system analysis.

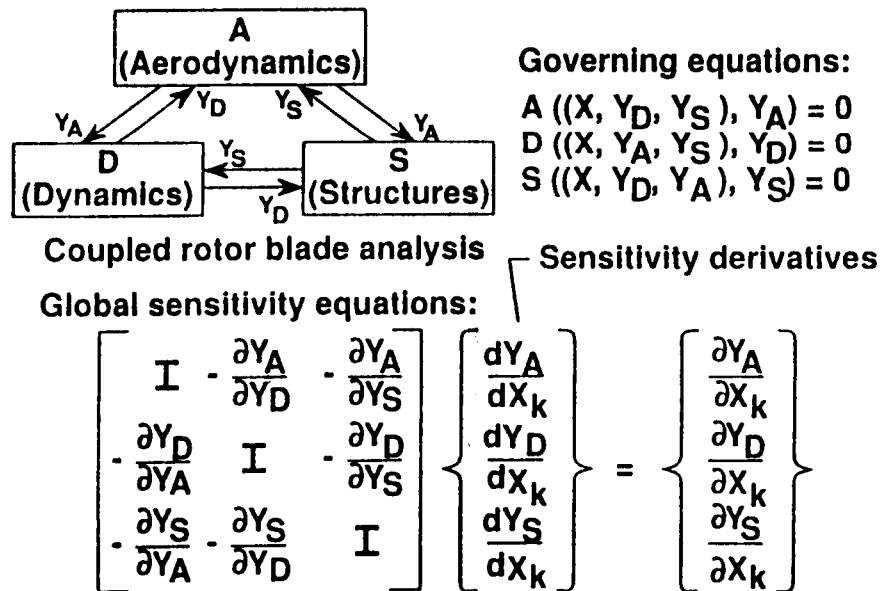

FIGURE 16

## MULTIPLE OBJECTIVE FUNCTION - GLOBAL CRITERIA APPROACH

As indicated before, the current optimization procedure requires a multiple objective function approach. Several methods have been proposed for the solution of multiobjective optimization problems. However, many of these methods suffer from a need for assigning relative priorities to the individual objective functions, e.g. assigning weight factors. The optimization goal is to find the set of design variables  $\phi$  which minimizes  $N$  objective functions  $(F_1(\phi), F_2(\phi), \dots, F_N(\phi))$  subject to a set of inequality constraints  $g_j$  ( $j=1,2,\dots,NCON$  where  $NCON$  denotes the total number of constraints). Using the Global Criteria Approach described in fig. 17, the optimum solution  $\phi^*$  is obtained by minimizing a prescribed 'global criterion'  $\hat{F}(\phi)$  which is defined as the sum of the squares of the relative deviations of the individual objective functions  $F_i(\phi)$  from their respective feasible optimum values  $F_i(\phi_i^*)$ . The optimum solution,  $\phi_i^*$ , to the  $i^{\text{th}}$  individual objective function is obtained by minimizing  $F_i(\phi)$  subject to the constraints  $g_j(\phi) \leq 0$ ,  $j=1,2,\dots,NCON$ . The optimization problem now is to minimize the composite objective function  $\hat{F}(\phi)$  subject to exactly the same set of constraints as used in the individual optimizations. The method is less judgmental in the sense it imposes equal priority to each individual objective function<sup>25</sup>.

- Optimization goal

Minimize "N" objective functions

$$F_1(\phi), F_2(\phi), F_3(\phi), \dots, F_N(\phi)$$

subject to  $g_j(\phi) \leq 0 \quad j = 1, 2, \dots, NCON$

- Global criterion formulation

Minimize

$$\hat{F}(\phi) = \sum_{i=1}^N \left\{ \frac{F_i(\phi) - F_i(\phi_i^*)}{F_i(\phi_i^*)} \right\}^2$$

subject to  $g_j(\phi) \leq 0 \quad j = 1, 2, \dots, NCON$

$(\phi_i^*)$  obtained from

Minimize  $F_i(\phi)$

subject to  $g_j(\phi) \leq 0 \quad j = 1, 2, \dots, NCON$

FIGURE 17

**FORMULATION OF STRUCTURAL OPTIMIZATION PROBLEM  
WITH INTEGRATED DYNAMICS/AIRLOADS USING GLOBAL CRITERIA APPROACH**

Using the the Global Criteria Approach the airload/dynamic optimization problem with multiple objective functions can be formulated as shown in fig. 18. The two objective functions  $F_1(\phi)$  and  $F_2(\phi)$  are the blade weight  $W$  and the blade root 4 per rev vertical shear  $F_z$ , respectively. The constraints are on the frequencies  $f_k$ ,  $k=1,2,\dots,6$  (three lead-lag and three flapping dominated modes), the blade stress  $\sigma$  and the blade autorotational inertia  $AI$ . Using the Global formulation the new global objective function  $F(\phi)$  is defined as the sum of the squares of the deviations of the objective functions,  $W$  and  $F_z$ , from their respective individual optimum values  $W^*$  and  $F_z^*$ . The optimization problem now is to minimize  $F(\phi)$  subject to the original set of constraints.

Multiple objective functions:  $F_1(\phi) = W$   
 $F_2(\phi) = F_z$

Constraints,  $g(\phi)$ :

$$1 - f_k / f_{kL} \leq 0$$

$$f_k / f_{kU} - 1 \leq 0$$

$$\alpha - AI \leq 0$$

$$\sigma \cdot FS - \sigma_{\max} \leq 0$$

Global objective function:

$$\hat{F}(\phi) = \left( \frac{W - W^*}{W^*} \right)^2 + \left( \frac{F_z - F_z^*}{F_z^*} \right)^2$$

subject to  $g(\phi) \leq 0$

FIGURE 18

**STUDY OF GLOBAL CRITERIA APPROACH FOR WEIGHT-STRESS OPTIMIZATION  
(BLADE IN VACUUM)**

Before attempting to solve the above integrated airload/dynamic optimization problem it was first decided to study the Global Criteria Approach for the dynamic optimization problem with the blade in vacuum and the blade weight and centrifugal stress as the two objective functions to be minimized (fig. 19). There  $F_1$  is equal to  $W$  which is the blade weight and  $F_2$  is equal to  $\sigma$  which represents the maximum centrifugal stress in the blade. The constraints are windows on the first coupled lead-lag dominated and the first flapping dominated frequencies and the blade autorotational inertia. The formulation of the test problem is shown in the figure. The new global objective function is a measure of the deviations of the individual objective functions,  $W$  and  $\sigma$ , from their respective optimum values  $W^*$  and  $\sigma^*$  and is denoted by  $\hat{F}(\phi)$ .

**Multiple objective functions:**

$$F_1(\phi) = W$$

$$F_2(\phi) = \sigma$$

**Constraints,  $g(\phi)$ :**

$$1 - f_k / f_{kL} \leq 0$$

$$f_k / f_{kU} - 1 \leq 0$$

$$\alpha - A \leq 0$$

**Global objective function:**

$$\hat{F}(\phi) = \left( \frac{W - W^*}{W^*} \right)^2 + \left( \frac{\sigma - \sigma^*}{\sigma^*} \right)^2$$

subject to  $g(\phi) \leq 0$

FIGURE 19

OPTIMIZATION RESULTS FOR RECTANGULAR BLADE USING GLOBAL CRITERIA APPROACH  
(BLADE IN VACUUM)

Following are the optimization results for the weight-stress optimization procedure discussed in the previous chart performed with the blade in vacuum. Figure 20 presents results obtained from the single objective function compared to those obtained from the multiple objective function formulation using the Global Criteria Approach. The results are for the rectangular blade with 30 design variables ( $t_1$ ,  $t_2$  and  $t_3$  at ten spanwise locations). Case 1 corresponds to the values obtained after optimization with blade weight as the single objective function and Case 2 refers to the values obtained after optimization with maximum centrifugal stress as the single objective function. Case 3 corresponds to the values obtained after optimization with multiple objective functions (blade weight and maximum centrifugal stress) using the Global Criteria Approach. When only the blade weight is minimized, the blade stress increases (Case 1). On the other hand when blade stress is minimized, the blade weight increases (Case 2). As shown using the Global Criteria Approach (Case 3), when considering both stress and blade weight simultaneously, the optimum results fall in between those obtained using only single objective functions. Compared to Case 1 the blade weight is slightly larger but the stress is much lower. Compared to Case 2 the blade weight is much lower and the stress is only slightly increased. The Global Criteria Approach therefore provides the 'best' compromise when two such conflicting objective functions are used.

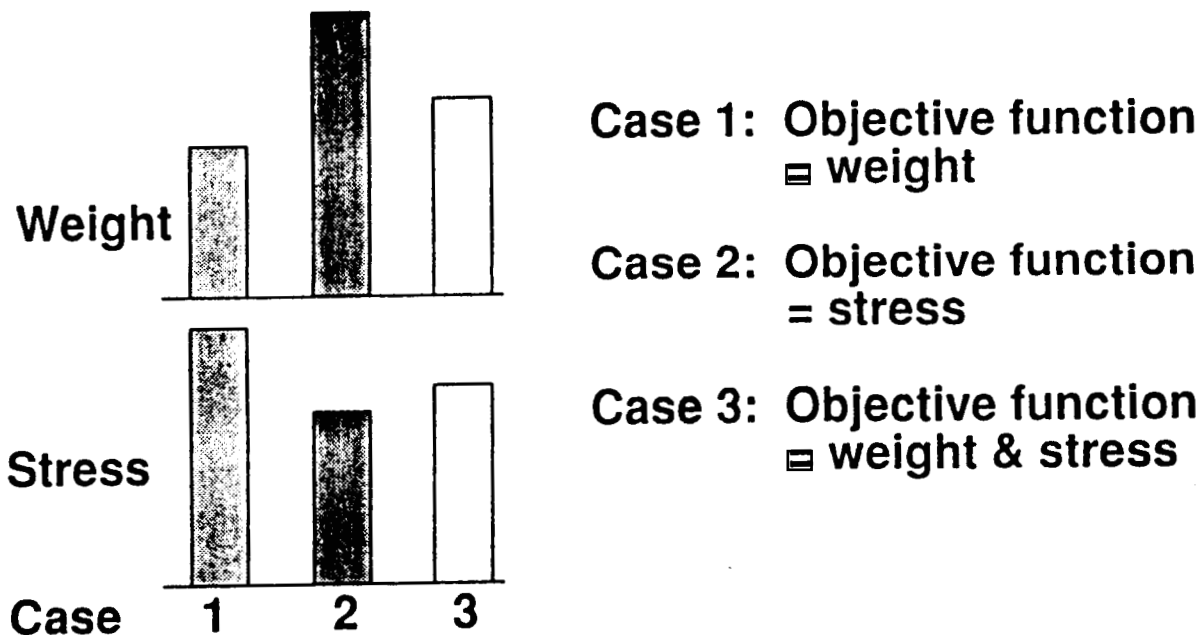

FIGURE 20

## CONCLUDING REMARKS

The paper addresses the problem of structural optimization of helicopter rotor blades with integrated dynamic and aerodynamic design considerations. Results of recent optimization work on rotor blades for minimum weight with constraints on multiple coupled natural flap-lag frequencies, blade autorotational inertia and centrifugal stress has been reviewed. A strategy has been defined for the ongoing activities in the integrated dynamic/aerodynamic optimization of rotor blades. As a first step the integrated dynamic/airload optimization problem has been formulated. To calculate system sensitivity derivatives necessary for the optimization recently developed Global Sensitivity Equations (GSE) are being investigated. A need for multiple objective functions for the integrated optimization problem has been demonstrated and various techniques for solving the multiple objective function optimization are being investigated. The method called the 'Global Criteria Approach' has been applied to a test problem with the blade in vacuum and the blade weight and the centrifugal stress as the multiple objectives. The results indicate that the method is quite effective in solving optimization problems with conflicting objective functions.

- Reviewed procedure for dynamic optimization with minimum weight objective and frequency, autorotational inertia and stress constraints
- Defined strategy for integrating the above with complete aerodynamic optimization
- Formulated integrated dynamic/airload optimization
- Investigating global sensitivity equations for calculating system sensitivity derivatives
- Described need for multiple objective functions
- Investigated 'Global Criteria' approach for multiple objective optimization

FIGURE 21

## REFERENCES

1. Ashley, H., "On Making Things the Best - Aeronautical Use of Optimization," AIAA J. Aircraft 19, No. 1, 1982.
2. Sobieszczanski-Sobieski, J., "Structural Optimization Challenges and Opportunities," presented at Int. Conference on Modern Vehicle Design Analysis, London, England, June 1983.
3. Miura, H., "Application of Numerical Optimization Method to Helicopter Design Problems: A Survey," NASA TM 86010, October 1984.
4. Bennett, R. L., "Application of Optimization Methods to Rotor Design Problems," Vertica, Vol. 7, No. 3, 1983, pp. 201-208.
5. Sobieszczanski-Sobieski, J., "Recent Experiences in Multidisciplinary Analysis and Optimization," NASA CP 2327, 1984.
6. Peters, D. A., Ko, Timothy, Rossow, Mark P., "Design of Helicopter Rotor Blades for Desired Placement of Natural Frequencies," Proc. of the 39th Annual Forum of the AHS, May 9-11, 1983, St. Louis, Missouri.
7. Taylor, R. B., "Helicopter Vibration Reduction by Rotor Blade Modal Shaping", Proc. of the 38th Annual Forum of the AHS, May 4-7, 1982, Anaheim, California.
8. Chattopadhyay, Aditi and Walsh, Joanne L., "Minimum Weight Design of Rectangular and Tapered Helicopter Rotor Blades with Frequency Constraints," Proc. of the 2nd Int. Conference on Rotorcraft Basic Research, February 16-18, 1988, College Park, Maryland. Also available as NASA TM 100561, February 1988.
9. Chattopadhyay, Aditi and Walsh, Joanne L., "Minimum Weight Design of Rotorcraft Blades with Multiple Frequency and Stress Constraints," Proc. of the AIAA/ASME/ASCE/AHS 29th Structures, Structural Dynamics and Materials Conference, Williamsburg, Virginia, April 18-20, 1988. AIAA Paper No. 88-2337-CP. Also available as NASA TM 100569, March 1988.
10. Weller, W. H. and Davis M. W., "Experimental Verification of Helicopter Blade Designs Optimized for Minimum Vibration," Proc. of the 44th Annual Forum of the AHS, June 16-18, 1988, Washington, D. C.
11. Walsh, J. L., Bingham, G. J., and Riley, M. F., Optimization Methods Applied to the Aerodynamic Design of Helicopter Rotor Blades. Journal of the American Helicopter Society, Vol 32, No. 4, October 1987.
12. Nixon, M. W., "Preliminary Structural Design of Composite Main Rotor Blades for Minimum Weight," NASA TP-2730, July 1987.
13. Peters, D. A., Ko, Timothy, Korn, Alfred, and Rossow, Mark P., "Design of Helicopter Rotor Blades for Desired Placements of Natural Frequencies," Proc. of the 39th Annual Forum of the AHS, May 9-11, 1983, St. Louis, Mo.
14. Hanagud, S., Chattopadhyay, Aditi, Yillikci, Y. K., Schrage, D., and Reichert, G., "Optimum Design of a Helicopter Rotor Blade," Paper No.



- 12, Proc. of the 12th European Rotorcraft Forum, September 22-25, 1986, Garmisch-Partenkirchen, West Germany.
15. Peters, D. A., Rossow, Mark P., Korn, Alfred, and Ko, Timothy, "Design of Helicopter Rotor Blades for Optimum Dynamic Characteristics," Computers & Mathematics with Applications, Vol. 12A, No. 1, 1986, pp. 85-109.
  16. Friedmann, P. P. and Shantakumaran, P., "Optimum Design of Rotor Blades for Vibration Reduction in Forward Flight," Proc. of the 39th Annual Forum of the AHS, May 9-11, 1983, St. Louis, Missouri.
  17. Celi, R. and Friedmann, P. P., "Efficient Structural Optimization of Rotor Blades with Straight and Swept Tips," Proc. of the 13th European Rotorcraft Forum, Arles, France, September 1987. Paper No. 3-1.
  18. Adelman, H. M. and Mantay, W. R., "An Initiative in Integrated Multidisciplinary Optimization of Rotorcraft," Presented at the Second NASA/Air Force Symposium on Recent Advances in Multidisciplinary Analysis and Optimization, Hampton, Virginia, September 28-30, 1988. Also available as NASA TM-101523 (AVSCOM TM 88-B-016), October 1988.
  19. Lim, Joon and Chopra, Inderjit, "Stability Sensitivity Analysis for the Aeroelastic Optimization of a Helicopter Rotor," Proc. of the AIAA/ASME/ASCE/AHS 29th Structures, Structural Dynamics and Materials Conference, Williamsburg, Virginia, April 18-20, 1988.
  20. Johnson, W., "A Comprehensive Analytical Model of Rotorcraft Aerodynamics and Dynamics," Part II: User's Manual, NASA TM 81183, June 1980.
  21. Lang, K. W., and Nemat-Nasser, S., "An Approach for Estimating Vibration Characteristics of Nonuniform Rotor Blades," AIAA Journal, Vol. 17, No. 9, September 1979.
  22. Johnson, W., "A Comprehensive Analytical Model of Rotorcraft Aerodynamics and Dynamics," Part I: Analysis Development, NASA TM 81182, June 1980.
  23. Vanderplaats, G. N., "CONMIN - A Fortran Program for Constrained Function Minimization," User's Manual, NASA TMX-62282, August 1973.
  24. Walsh, Joanne L., "Applications of Numerical Optimization Procedures to a Structural Model of a Large Finite-Element Wing," NASA TM 87597, 1986.
  25. Rao, S. S., "Multiobjective Optimization in Structural Design with Uncertain Parameters and Stochastic Processes," AIAA Journal, Vol. 22, No. 11, November 1984.
  26. Callahan, C. and Bassett, D., "Application of a Comprehensive Analytical Model of Rotorcraft Aerodynamics and Dynamics (CAMRAD) to the McDonnell Douglas AH-64A Helicopter," Proc. of 43rd Annual AHS Forum, St. Louis, Missouri, May 18-20, 1987, pp. 293-355.
  27. Sobieszczanski-Sobieski, J., "On the Sensitivity of Complex Internally Coupled Systems," NASA TM 100537, January 1988.



# Report Documentation Page

1. Report No. <b>NASA TM-101512</b>		2. Government Accession No.		3. Recipient's Catalog No.	
4. Title and Subtitle <b>Structural Optimization of Rotor Blades with Integrated Dynamics and Aerodynamics</b>				5. Report Date <b>October 1988</b>	
				6. Performing Organization Code	
7. Author(s) <b>Aditi Chattopadhyay and Joanne L. Walsh</b>				8. Performing Organization Report No.	
				10. Work Unit No. <b>505-63-51-10</b>	
9. Performing Organization Name and Address <b>NASA Langley Research Center Hampton, VA 23665-5225</b>				11. Contract or Grant No.	
				13. Type of Report and Period Covered <b>Technical Memorandum</b>	
12. Sponsoring Agency Name and Address <b>National Aeronautics and Space Administration Washington, DC 20546-0001</b>				14. Sponsoring Agency Code	
				15. Supplementary Notes <b>Aditi Chattopadhyay, Analytical Services and Materials, Inc., Hampton, VA; Joanne L. Walsh, Langley Research Center, Hampton, VA. Presented at Second NASA/Air Force Symposium on Recent Advances in Multidisciplinary Analysis and Optimization, Hampton, VA, Sept. 28-30, 1988.</b>	
16. Abstract The paper addresses the problem of structural optimization of helicopter rotor blades with integrated dynamic and aerodynamic design considerations. Results of recent optimization work on rotor blades for minimum weight with constraints on multiple coupled natural flap-lag frequencies, blade autorotational inertia and centrifugal stress has been reviewed. A strategy has been defined for the ongoing activities in the integrated dynamic/aerodynamic optimization of rotor blades. As a first step, the integrated dynamic/airload optimization problem has been formulated. To calculate system sensitivity derivatives necessary for the optimization recently developed, Global Sensitivity Equations (GSE) are being investigated. A need for multiple objective functions for the integrated optimization problem has been demonstrated and various techniques for solving the multiple objective function optimization are being investigated. The method called the "Global Criteria Approach" has been applied to a test problem with the blade in vacuum and the blade weight and the centrifugal stress as the multiple objectives. The results indicate that the method is quite effective in solving optimization problems with conflicting objective functions.					
17. Key Words (Suggested by Author(s)) <b>Helicopter Dynamics Rotor blade Structural optimization Aerodynamics</b>			18. Distribution Statement <b>Unclassified - Unlimited Subject Category 05</b>		
19. Security Classif. (of this report) <b>Unclassified</b>		20. Security Classif. (of this page) <b>Unclassified</b>		21. No. of pages <b>25</b>	22. Price <b>A02</b>