

**NASA  
Technical  
Paper  
2835**

1988

User's Manual for Interactive  
LINEAR, a FORTRAN Program  
To Derive Linear Aircraft Models

Robert F. Antoniewicz,  
Eugene L. Duke,  
and Brian P. Patterson  
*Ames Research Center  
Dryden Flight Research Facility  
Edwards, California*



National Aeronautics  
and Space Administration

Scientific and Technical  
Information Division

CONTENTS

SUMMARY . . . . . 1

INTRODUCTION . . . . . 1

NOMENCLATURE . . . . . 2

    Variables . . . . . 2

    Superscripts . . . . . 6

    Subscripts . . . . . 6

    FORTRAN Variables . . . . . 7

PROGRAM OVERVIEW . . . . . 11

EQUATIONS OF MOTION . . . . . 14

OBSERVATION EQUATIONS . . . . . 17

SELECTION OF STATE, CONTROL, AND OBSERVATION VARIABLES . . . . . 22

LINEAR MODELS . . . . . 22

ANALYSIS POINT DEFINITION . . . . . 25

    Untrimmed . . . . . 26

    Straight-and-Level Trim . . . . . 27

    Pushover-Pullup . . . . . 27

    Level Turn . . . . . 28

    Thrust-Stabilized Turn . . . . . 29

    Beta Trim . . . . . 29

    Specific Power . . . . . 29

NONDIMENSIONAL STABILITY AND CONTROL DERIVATIVES . . . . . 31

DATA INPUT . . . . . 33

    Input Files . . . . . 33

    Title Information . . . . . 33

    Geometry and Mass Data . . . . . 33

    State, Control, and Observation Variable Definitions . . . . . 34

    Trim Parameter Specification . . . . . 37

    Additional Surface Specification . . . . . 37

    Test Case Specification . . . . . 38

    Interactive Data Input . . . . . 38

AERODYNAMIC MODEL . . . . . 46

OUTPUT FILES . . . . . 48

USER-SUPPLIED SUBROUTINES . . . . . 49

    Aerodynamic Model Subroutines . . . . . 50

    Control Model Subroutines . . . . . 52

    Engine Model Subroutines . . . . . 53

    Mass and Geometry Model Subroutines . . . . . 53

CONCLUDING REMARKS . . . . .	5
APPENDIX A: CORRECTIONS TO AERODYNAMIC COEFFICIENTS FOR A CENTER OF GRAVITY NOT AT THE AERODYNAMIC REFERENCE POINT . . . . .	5
APPENDIX B: ENGINE TORQUE AND GYROSCOPIC EFFECTS MODEL . . . . .	5
APPENDIX C: OBSERVATION VARIABLE NAMES RECOGNIZED BY LINEAR . . . . .	6
APPENDIX D: STATE VARIABLE NAMES RECOGNIZED BY LINEAR . . . . .	7
APPENDIX E: ANALYSIS POINT DEFINITION IDENTIFIERS . . . . .	7
APPENDIX F: EXAMPLE INPUT FILE . . . . .	7
APPENDIX G: EXAMPLE LINEARIZED STABILITY AND CONTROL DERIVATIVE FILE . . . . .	8
APPENDIX H: EXAMPLE OUTPUT ANALYSIS FILE . . . . .	8
APPENDIX I: EXAMPLE PRINTER OUTPUT FILE . . . . .	9
APPENDIX J: EXAMPLE USER-SUPPLIED SUBROUTINES . . . . .	10
Aerodynamic Model Subroutines . . . . .	10
Control Model Subroutine . . . . .	11
Engine Model Interface Subroutine . . . . .	11
Mass and Geometry Model . . . . .	11
REFERENCES . . . . .	11

## SUMMARY

An interactive FORTRAN program that provides the user with a powerful and flexible tool for the linearization of aircraft aerodynamic models is documented in this report. The program LINEAR numerically determines a linear system model using nonlinear equations of motion and a user-supplied linear or nonlinear aerodynamic model. The nonlinear equations of motion used are six-degree-of-freedom equations with stationary atmosphere and flat, nonrotating earth assumptions. The system model determined by LINEAR consists of matrices for both the state and observation equations. The program has been designed to allow easy selection and definition of the state, control, and observation variables to be used in a particular model.

## INTRODUCTION

The program LINEAR described in this report was developed at the Dryden Flight Research Facility of the NASA Ames Research Center to provide a standard, documented, and verified tool to derive linear models for aircraft stability analysis and control law design. This development was undertaken to address the need for the aircraft specific linearization programs common in the aerospace industry. Also, the lack of available documented linearization programs provided a strong motivation for the development of LINEAR; in fact, the only available documented linearization program that was found in an extensive literature search of the field is that of Kalviste (1980).

Linear system models of aircraft dynamics and sensors are an essential part of both vehicle stability analysis and control law design. These models define the aircraft system in the neighborhood of an analysis point and are determined by the linearization of the nonlinear equations defining vehicle dynamics and sensors. This report describes a FORTRAN program that provides the user with a powerful and flexible tool for the linearization of aircraft models. LINEAR is a program with well-defined and generalized interfaces to aerodynamic and engine models and is designed to address a wide range of problems without the requirement of program modification.

The program LINEAR numerically determines a linear system model using nonlinear equations of motion and a user-supplied linear or nonlinear aerodynamic model. LINEAR is also capable of extracting both linearized engine effects, such as net thrust, torque, and gyroscopic effects and including these effects in the linear system model. The point at which this linear system model is defined is determined either by completely specifying the state and control variables, or by specifying an analysis point on a trajectory and directing the program to determine the control variables and remaining state variables.

The system model determined by LINEAR consists of matrices for both the state and observation equations. The program has been designed to provide easy selection of the state, control, and observation variables to be used in a particular model. Thus, the order of the system model is completely under user control. Further, the program provides the flexibility of allowing alternate formulations of both the state and observation equations.

LINEAR has several features that make it unique among the linearization programs common in the aerospace industry. The most significant of these features is flexibility. By generalizing the surface definitions and making no assumptions of symmetric mass distributions, the program can be applied to any aircraft in any phase of flight except hover. The unique trimming capability, provided by means of a user supplied subroutine, allows unlimited possibilities of trimming strategies and surface scheduling, which are particularly important for asymmetrical vehicles and aircraft having multiple surfaces affecting a single axis. The formulation of the equations of motion permits the inclusion of thrust-vectoring effects. The ability to select variables for the state, control, and observation vectors of the linear models, without program modification, combined with the vast array of observation variables available, allows any analysis problem to be attacked with ease.

The interactive LINEAR program is an extension of the batch LINEAR program described in Duke and others (1987). Data describing the aircraft and test case are input to the program through a terminal or formatted data files similar to the input files for the batch program. All data can be modified interactively from case to case. The aerodynamic model can be defined in two ways: a set of nondimensional stability and control derivatives for the flight point of interest, or a full nonlinear aerodynamic model as used in simulations at Ames-Dryden.

#### NOMENCLATURE

The units associated with the following quantities are expressed in the English system. LINEAR will work equally well with any consistent set of units with two notable exceptions: the printed output and the atmospheric model. Both the printed output and the atmospheric model assume English units.

Where applicable, quantities are defined with respect to the body axis system.

#### Variables

A	state matrix of the state equation $\dot{\mathbf{x}} = \mathbf{Ax} + \mathbf{Bu}$ ; or, axial force (lb)
A'	state matrix of the state equation $\dot{\mathbf{Cx}} = \mathbf{A}'\mathbf{x} + \mathbf{B}'\mathbf{u}$
a	speed of sound in air (ft/sec)
$a_{n,i}$	normal acceleration not at center of gravity (g)
$a_{nx}$	x body axis accelerometer at center of gravity (g)
$a_{nx,i}$	x body axis accelerometer not at center of gravity (g)
$a_{ny}$	y body axis accelerometer at center of gravity (g)
$a_{ny,i}$	y body axis accelerometer not at center of gravity (g)
$a_{nz}$	z body axis accelerometer at center of gravity (g)

$a_{nz,i}$  z body axis accelerometer not at center of gravity (g)  
 $a_x$  acceleration along the x body axis (g)  
 $a_y$  acceleration along the y body axis (g)  
 $a_z$  acceleration along the z body axis (g)  
B control matrix of the state equation  $\dot{x} = Ax + Bu$   
 $B'$  control matrix of the state equation  $C\dot{x} = A'x + B'u$   
b wingspan (ft)  
C C matrix of the state equation  $C\dot{x} = A'x + B'u$ ; or, force or moment coefficient  
 $\bar{c}$  mean aerodynamic chord (ft)  
D dynamic interaction matrix for the state equation  $\dot{x} = Ax + Bu + Dv$ ; or, drag force (lb)  
 $D'$  dynamic interaction matrix for the state equation  $C\dot{x} = A'x + B'u + D'v$   
det determinant  
E dynamic interaction matrix for the observation equation  $y = Hx + Fu + Ev$   
 $E'$  dynamic interaction matrix for the observation equation  
 $y = H'x + G\dot{x} + F'u + E'v$   
 $E_s$  specific energy (ft)  
F feedforward matrix of the observation equation  $y = Hx + Fu$   
 $F'$  feedforward matrix of the observation equation  $\dot{y} = H'x + Gx + F'u$   
fpa flight path acceleration (g)  
G G matrix of the observation equation  $y = H'x + G\dot{x} + F'u$   
g acceleration due to gravity (ft/sec<sup>2</sup>)  
h altitude (ft)  
H observation matrix of the observation equation  $y = Hx + Fu$

$H'$	observation matrix of the observation equation $y = H'x + G\dot{x} + F'u$
$h_i$	angular momentum of engine rotor (slug-ft <sup>2</sup> /sec)
$I$	aircraft inertia tensor (slug-ft <sup>2</sup> )
$I_e$	rotational inertia of the engine (slug-ft <sup>2</sup> )
$I_x$	x body axis moment of inertia (slug-ft <sup>2</sup> )
$I_{xy}$	x-y body axis product of inertia (slug-ft <sup>2</sup> )
$I_{xz}$	x-z body axis product of inertia (slug-ft <sup>2</sup> )
$I_y$	y body axis moment of inertia (slug-ft <sup>2</sup> )
$I_{yz}$	y-z body axis product of inertia (slug-ft <sup>2</sup> )
$I_z$	z body axis moment of inertia (slug-ft <sup>2</sup> )
$L$	total body axis rolling moment (ft-lb)
$l$	generalized length (ft)
$M$	Mach number; or, total body axis pitching moment (ft-lb)
$m$	aircraft total mass (slug)
$N$	normal force (lb); or, total body axis yawing moment (ft-lb)
$n$	load factor
$P_s$	specific power (ft/sec)
$p$	roll rate (rad/sec)
$p_a$	ambient pressure (lb/ft <sup>2</sup> )
$p_t$	total pressure (lb/ft <sup>2</sup> )
$q$	pitch rate (rad/sec)
$\bar{q}$	dynamic pressure (lb/ft <sup>2</sup> )
$q_c$	impact pressure (lb/ft <sup>2</sup> )
$r$	yaw rate (rad/sec)

Re Reynolds number  
 Re' Reynolds number per unit length (ft<sup>-1</sup>)  
 S wing planform area (ft<sup>2</sup>)  
 T ambient temperature (°R); or, total angular momentum (slug-ft<sup>2</sup>/sec<sup>2</sup>)  
 T<sub>t</sub> total temperature (°R)  
 u velocity in x-axis direction (ft/sec)  
 u control vector  
 V total velocity (ft/sec)  
 v velocity in y-axis direction (ft/sec)  
 v dynamic interaction vector  
 V<sub>C</sub> calibrated velocity (ft/sec)  
 V<sub>e</sub> equivalent velocity (ft/sec)  
 W vehicle weight (lb)  
 w velocity in z-axis direction (ft/sec)  
 X total force along the x body axis (lb)  
 x state vector  
 X<sub>t</sub> thrust along the x body axis (lb)  
 Y sideforce (lb)  
 y observation vector  
 Y<sub>T</sub> thrust along the y body axis (lb)  
 Z total force along the z body axis (lb)  
 Z<sub>t</sub> thrust along the z body axis (lb)  
 α angle of attack (rad)  
 β angle of sideslip (rad)  
 γ flight path angle (rad)  
 Δx displacement of engine from center of gravity along x body axis (ft)



$\Delta y$	displacement of engine from center of gravity along y body axis (ft)
$\Delta z$	displacement of engine from center of gravity along z body axis (ft)
$\delta_a$	lateral trim parameter
$\delta_e$	longitudinal trim parameter
$\delta L$	incremental rolling moment (ft-lb)
$\delta M$	incremental pitching moment (ft-lb)
$\delta N$	incremental yawing moment (ft-lb)
$\delta_r$	directional trim parameter
$\delta_{th}$	thrust trim parameter
$\delta X$	incremental x body axis force (lb)
$\delta Y$	incremental y body axis force (lb)
$\delta Z$	incremental z body axis force (lb)
$\theta$	pitch angle (rad)
$\rho$	density of air (slug/ft <sup>3</sup> )
$\tau$	torque from engines (ft-lb)
$\tau_g$	gyroscopic torque from engines (ft-lb)
$\phi$	roll angle (rad)
$\phi_L$	tilt angle of acceleration normal to the flightpath from the vertical plane (rad)
$\psi$	heading angle (rad)
$\omega_e$	engine angular velocity (rad/sec)

#### Superscripts

•	derivative with respect to time
T	transpose of a vector or matrix

#### Subscripts

ar	aerodynamic reference point
D	total drag

h	altitude
L	total lift
l	rolling moment
M	Mach number
m	pitching moment
max	maximum
min	minimum
n	yawing moment
p	roll rate
q	pitch rate
r	yaw rate
s	stability axis
x	along the x body axis
y	along the y body axis
Y	sideforce
z	along the z body axis
o	standard day, sea level conditions; or, along the reference trajectory

#### FORTRAN Variables

AIX	inertia about the x body axis
AIXE	engine inertia
AIXY	inertia coupling between the x and y body axes
AIXZ	inertia coupling between the x and z body axes
AIY	inertia about the y body axis
AIYZ	inertia coupling between the y and z body axes
AIZ	inertia about the z body axis
ALP	angle of attack
ALPDOT	time rate of change of angle of attack

AMCH	Mach number
AMSENG	total rotor mass of the engine
AMSS	aircraft mass
B	wingspan
BTA	angle of sideslip
BTADOT	time rate of change of angle of sideslip
CBAR	mean aerodynamic chord
CD	total coefficient of drag
CDA	coefficient of drag due to angle of attack
CDDE	coefficient of drag due to symmetric elevator deflection
CDO	drag coefficient at zero angle of attack
CDSB	coefficient of drag due to speed brake deflection
CL	total coefficient of rolling moment
CLB	coefficient of rolling moment due to beta
CLDA	coefficient of rolling moment due to aileron deflection
CLDR	coefficient of rolling moment due to rudder deflection
CLDT	coefficient of rolling moment due to differential elevator deflection
CLFT	total coefficient of lift
CLFTA	coefficient of lift due to angle of attack
CLFTAD	coefficient of lift due to angle-of-attack rate
CLFTDE	coefficient of lift due to symmetric elevator deflection
CLFTO	lift coefficient at zero angle of attack
CLFTQ	coefficient of lift due to pitch rate
CLFTSB	coefficient of lift due to speed brake deflection
CLP	coefficient of rolling moment due to roll rate
CLR	coefficient of rolling moment due to yaw rate
CM	total coefficient of pitching moment

CMA coefficient of pitching moment due to angle of attack  
 CMAD coefficient of pitching moment due to angle-of-attack rate  
 CMDE coefficient of pitching moment due to symmetric elevator deflection  
 CMO pitching moment coefficient at zero angle of attack  
 CMQ coefficient of pitching moment due to pitch rate  
 CMSB coefficient of pitching moment due to speed brake deflection  
 CN total coefficient of yawing moment  
 CNB coefficient of yawing moment due to sideslip  
 CNDA coefficient of yawing moment due to aileron deflection  
 CNDR coefficient of yawing moment due to rudder deflection  
 CNDT coefficient of yawing moment due to differential elevator deflection  
 CNP coefficient of yawing moment due to roll rate  
 CNR coefficient of yawing moment due to yaw rate  
 CY total coefficient of sideforce  
 CYB coefficient of sideforce due to sideslip  
 CYDA coefficient of sideforce due to aileron deflection  
 CYDR coefficient of sideforce due to rudder deflection  
 CYDT coefficient of sideforce due to differential elevator deflection  
 DAS lateral trim parameter  
 DC surface deflection and thrust control array  
 DELX displacement of the aerodynamic reference point along the x body axis from  
 the vehicle center of gravity  
 DELY displacement of the aerodynamic reference point along the y body axis from  
 the vehicle center of gravity  
 DELZ displacement of the aerodynamic reference point along the z body axis from  
 the vehicle center of gravity  
 DES longitudinal trim parameter

DRS	directional trim parameter
DXTHRS	distance between the center of gravity of the engine and the thrust point
EIX	rotational inertia of the engine
ENGOMG	rotational velocity of the engine
GMA	flightpath angle
H	altitude
HDOT	time rate of change of altitude
NUMSAT	number of states in the state vector
NUMSRF	number of recognizable control names
P	roll rate
PDOT	time rate of change of roll rate
PHI	roll angle
PHIDOT	time rate of change of roll angle
PSI	heading angle
PSIDOT	time rate of change of heading angle
Q	pitch rate
QBAR	dynamic pressure
QDOT	time rate of change of pitch rate
R	yaw rate
RDOT	time rate of change of yaw rate
S	wing area
T	time
TDOT	time rate of change of time
THA	pitch angle
THADOT	time rate of change of pitch angle
THRSTX	thrust trim parameter
THRUST	thrust generated by each engine

TLOCAT location of the engine in the x, y, and z axes from the center of gravity

TVANXY orientation of the thrust vector in the x-y engine axis plane

TVANXZ orientation of the thrust vector in the x-z engine axis plane

UB velocity along the x body axis

V velocity

VB velocity along the y body axis

VCAS calibrated airspeed

VDOT time rate of change of total vehicle velocity

VEAS equivalent airspeed

WB velocity along the z body axis

X position north from an arbitrary reference point

XDOT time rate of change of north-south position

XYANGL orientation of thrust vector in x-y body axis plane

XZANGL orientation of thrust vector in x-z body axis plane

Y position east from an arbitrary reference point

YDOT time rate of change of east-west position

#### PROGRAM OVERVIEW

The program LINEAR numerically determines a linear system model using nonlinear equations of motion and a user-supplied nonlinear aerodynamic model. LINEAR is also capable of extracting linearized gross engine effects, such as net thrust, torque, and gyroscopic effects and including these effects in the linear system model. The point at which this linear system model is defined is determined either by specifying the state and control variables or by selecting an analysis point on a trajectory, selecting a trim option, and allowing the program to determine the control variables and remaining state variables to satisfy the trim option selected.

Because the program is designed to satisfy the needs of a broad class of users, a wide variety of options has been provided. Perhaps the most important of these options are those that allow user specification of the state, control, and observation variables to be included in the linear model derived by LINEAR.

Within the program, the nonlinear equations of motion include 12 states representing a rigid aircraft flying in a stationary atmosphere over a flat, nonrotating earth. Thus, internally, the state vector  $\mathbf{x}$  is computed as

$$\mathbf{x} = [p \ q \ r \ v \ \alpha \ \beta \ \phi \ \theta \ \psi \ h \ x \ y]^T$$

The nonlinear equations used to determine the derivatives of the states are presented in the following section. The internal control vector  $u$  can contain up to 30 controls. The internal observation vector  $y$  contains 120 variables including the state variables, the time derivatives of the state variables, the control variables, and a variety of other parameters of interest. Thus, within the program,

$$y = [x^T \quad \dot{x}^T \quad u^T \quad y_1^T \quad y_2^T \quad y_3^T \quad y_4^T \quad y_5^T \quad y_6^T \quad y_7^T \quad y_8^T]^T$$

where

$$y_1 = [a_x \quad a_y \quad a_z \quad a_{nx} \quad a_{ny} \quad a_{nz} \quad a_n \quad a_{nx,i} \quad a_{ny,i} \quad a_{nz,i} \quad a_{n,i} \quad n]^T$$

$$y_2 = [a \quad Re \quad Re' \quad M \quad \bar{q} \quad q_c \quad p_a \quad q_c/p_a \quad p_t \quad T \quad T_t \quad v_e \quad v_c]^T$$

$$y_3 = [\gamma \quad fpa \quad \dot{\gamma} \quad \ddot{h} \quad \dot{h}/57.3]^T$$

$$y_4 = [E_s \quad p_s]^T$$

$$y_5 = [L \quad D \quad N \quad A]^T$$

$$y_6 = [u \quad v \quad w \quad \dot{u} \quad \dot{v} \quad \dot{w}]^T$$

$$y_7 = [\alpha_{,i} \quad \beta_{,i} \quad h_{,i} \quad \dot{h}_{,i}]^T$$

and

$$y_8 = [T \quad p_s \quad q_s \quad r_s]^T$$

The equations defining these quantities are presented in the Observation Equations section.

From the internal formulation of the state, control, and observation variables, the user must select the specific variables desired in the output linear model (described in the Selection of State, Control, and Observation Variables section). Internally, the program uses a 12-state vector, 120-variable observation vector, and a 30-parameter control vector. These variables can be selected to specify the formulation most suited for the specific application. The order and number of parameters in the output model are completely under user control. Figure 1 shows the selection of the variables in the state vector for a requested linear model. From the internal formulation on

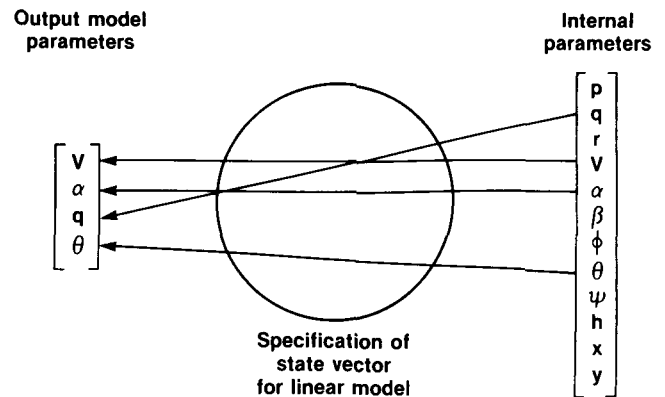

Figure 1. Selection of state variables for linear model.

the right, the requested model is constructed, and the linear system matrices are selected in accordance with the user specification of the state, control, and observation variables.

The linear model derived by LINEAR is determined at an analysis point. LINEAR allows this analysis point to be defined as a true steady-state condition on a specified trajectory (a point at which the rotational and translational accelerations are zero) or a totally arbitrary state on a trajectory. The program LINEAR provides the user with several options described in detail in the Analysis Point Definition section of this report. These analysis point definition options allow the user to trim the aircraft in wings-level flight, pushovers, pullups, level turns, or zero-sideslip maneuvers. Also included is a nontrimming option in which the user defines a totally arbitrary condition about which the linear model is to be derived.

The linear system matrices are determined by numerical perturbation and are the first-order terms of a Taylor series expansion about the analysis point as described in the Linear Models section. The formulation of the output system model is under user control. The user can select state equation matrices corresponding to either the standard formulation of the state equation

$$\dot{\mathbf{x}} = \mathbf{A}\mathbf{x} + \mathbf{B}\mathbf{u}$$

or the generalized equation

$$\mathbf{C}\dot{\mathbf{x}} = \mathbf{A}'\mathbf{x} + \mathbf{B}'\mathbf{u}$$

The observation matrices can be selected from either of two formulations corresponding to the standard equation

$$\mathbf{y} = \mathbf{H}\mathbf{x} + \mathbf{F}\mathbf{u}$$

or the generalized equation

$$\mathbf{y} = \mathbf{H}'\mathbf{x} + \mathbf{G}\dot{\mathbf{x}} + \mathbf{F}'\mathbf{u}$$

In addition to the linear system matrices, LINEAR also computes the nondimensional stability and control derivatives at the analysis point. These derivatives are discussed in the Aerodynamic Model section.

Aircraft geometry and mass properties and analysis point definition are input interactively to the program or are read from ASCII files of 80-character records specified by the user. The state, control, and observation vectors are also defined in either manner. The details of data input are discussed in the Data Input section.

The output of LINEAR consists of the following four files: one is intended to be used with follow-on design and analysis programs, two document the options and analysis points selected by the user, and one contains stability and control derivatives extracted at the analysis point. The first of these files contains the state, control, and observation vector name lists and values, and the state space system matrices. The second file contains all of the trim information, the control, state,



and observation values, the trim control input positions, and the nondimensional stability and control derivative data. It will also contain the output of the equations of motion if the program fails to attain a trimmed condition. The third file contains all of the information in the second file plus the state space system model matrices. The fourth file contains the stability and control derivatives extracted at the analysis point in a form suitable to be read back into LINEAR as a linear aerodynamic model.

To execute LINEAR, five user-supplied subroutines are required. These routines, discussed in the User-Supplied Subroutines section, define the nonlinear aerodynamic model, the gross engine model, the gearing between the LINEAR trim inputs and the surfaces modeled in the aerodynamic model, and a model of the mass and geometry properties of the aircraft. The control model, shown in figure 2, defines how the LINEAR trim inputs will be connected to the surface models and allows schedules and nonstandard trimming schemes to be used. The last feature is particularly important for asymmetrical aircraft.

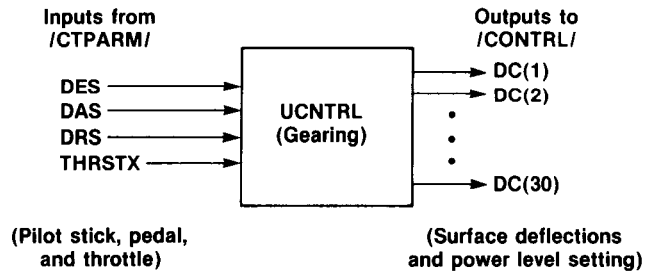

**Figure 2. Inputs and outputs to the user-supplied subroutine UCNTRL.**

#### EQUATIONS OF MOTION

The nonlinear equations of motion used in the linearization program are general six-degree-of-freedom equations representing the flight dynamics of a rigid aircraft flying in a stationary atmosphere over a flat nonrotating earth. The assumption of nonzero forward motion also is included in these equations. Because of this assumption, these equations are invalid for vertical takeoff and landing or hover. These equations contain no assumptions of either symmetric mass distribution or aerodynamic properties and are applicable to asymmetric aircraft (such as oblique-wing aircraft) as well as to conventional symmetric aircraft. These equations of motion were derived by Etkin (1972), and the derivation is detailed in the NASA Reference Publication, "Derivation and Definition of a Linear Aircraft Model," by Eugene L. Duke, Robert F. Antoniewicz, and Keith D. Krambeer.

The following equations for rotational acceleration are used for analysis point definition:

$$\begin{aligned} \dot{p} = & [(\Sigma L)I_1 + (\Sigma M)I_2 + (\Sigma N)I_3 - p^2(I_{xz}I_2 - I_{xy}I_3) \\ & + pq(I_{xz}I_1 - I_{yz}I_2 - D_z I_3) - pr(I_{xy}I_1 + D_y I_2 - I_{yz}I_3) \\ & + q^2(I_{yz}I_1 - I_{xy}I_3) - qr(D_x I_1 - I_{xy}I_2 + I_{xz}I_3) \\ & - r^2(I_{yz}I_1 - I_{xz}I_2)]/\det I \end{aligned}$$

$$\begin{aligned} \dot{q} = & [(\Sigma L)I_2 + (\Sigma M)I_4 + (\Sigma N)I_5 - p^2(I_{xz}I_4 - I_{xy}I_5) \\ & + pq(I_{xz}I_2 - I_{yz}I_4 - D_z I_5) - pr(I_{xy}I_2 + D_y I_4 - I_{yz}I_5) \\ & + q^2(I_{yz}I_2 - I_{xy}I_5) - qr(D_x I_2 - I_{xy}I_4 + I_{xz}I_5) \\ & - r^2(I_{yz}I_2 - I_{xz}I_4)]/\det I \end{aligned}$$

$$\begin{aligned} \dot{r} = & [(\Sigma L)I_3 + (\Sigma M)I_5 + (\Sigma N)I_6 - p^2(I_{xz}I_5 - I_{xy}I_6) \\ & + pq(I_{xz}I_3 - I_{yz}I_5 - D_z I_6) - pr(I_{xy}I_3 + D_y I_5 - I_{yz}I_6) \\ & + q^2(I_{yz}I_3 - I_{xy}I_6) - qr(D_x I_3 - I_{xy}I_5 + I_{xz}I_6) \\ & - r^2(I_{yz}I_3 - I_{xz}I_5)]/\det I \end{aligned}$$

where

$$\det I = I_x I_y I_z - 2I_{xy} I_{xz} I_{yz} - I_x I_z^2 - I_y I_x^2 - I_z I_y^2$$

$$I_1 = I_y I_z - I_{yz}^2$$

$$I_2 = I_{xy} I_z + I_{yz} I_{xz}$$

$$I_3 = I_{xy} I_{yz} + I_y I_{xz}$$

$$I_4 = I_x I_z - I_{xz}^2$$

$$I_5 = I_x I_{yz} + I_{xy} I_{xz}$$

$$I_6 = I_x I_y - I_{xy}^2$$

$$D_x = I_z - I_y$$

$$D_y = I_x - I_z$$

$$D_z = I_y - I_x$$

Here, the body axis rates are designated  $p$ ,  $q$ , and  $r$ , corresponding to roll rate, pitch rate, and yaw rate. The total moments about the  $x$ ,  $y$ , and  $z$  body axes are designated  $\Sigma L$ ,  $\Sigma M$ , and  $\Sigma N$ , respectively. These total moments are the sums of all

aerodynamic moments and powerplant-induced moments due to thrust asymmetries and gyroscopic torques. The equations used to determine the change in moment coefficients due to the noncoincidence of the vehicle center of gravity and the reference point of the nonlinear aerodynamic model are derived in appendix A. The equations defining the engine torque and gyroscopic contributions to the total moments are derived in appendix B. The body axis moments of inertia are designated  $I_x$ ,  $I_y$ , and  $I_z$ . The products of inertia are designated  $I_{xy}$ ,  $I_{xz}$ , and  $I_{yz}$ . These moments and products of inertia are elements of the inertia tensor  $I$ , defined as

$$I = \begin{bmatrix} I_x & -I_{xy} & -I_{xz} \\ -I_{xy} & I_y & -I_{yz} \\ -I_{xz} & -I_{yz} & I_z \end{bmatrix}$$

To derive the state equation matrices for the generalized formulation

$$C\dot{x} = Ax + Bu$$

the rotational accelerations are cast in a decoupled-axes formulation. The equations used to derive the linearized matrices are

$$\begin{bmatrix} 1 & \frac{-I_{xy}}{I_x} & \frac{-I_{xz}}{I_x} \\ \frac{-I_{xy}}{I_y} & 1 & \frac{-I_{yz}}{I_y} \\ \frac{-I_{xz}}{I_z} & \frac{-I_{yz}}{I_z} & 1 \end{bmatrix} \begin{bmatrix} \dot{p} \\ \dot{q} \\ \dot{r} \end{bmatrix} = \begin{bmatrix} \frac{\Sigma L}{I_x} - rp \frac{I_{xy}}{I_x} + pq \frac{I_{xz}}{I_x} + rq \frac{I_y}{I_x} + (q^2 - r^2) \frac{I_{yz}}{I_x} - qr \frac{I_z}{I_x} \\ \frac{\Sigma M}{I_y} - rp \frac{I_x}{I_y} + rq \frac{I_{xy}}{I_y} - pq \frac{I_{yz}}{I_y} + (r^2 - p^2) \frac{I_{xz}}{I_y} + pr \frac{I_z}{I_y} \\ \frac{\Sigma N}{I_z} + qp \frac{I_x}{I_z} - qr \frac{I_{xz}}{I_z} + pr \frac{I_{yz}}{I_z} + (p^2 - q^2) \frac{I_{xy}}{I_z} - pq \frac{I_y}{I_z} \end{bmatrix}$$

The translational acceleration equations used in the program LINEAR for both analysis point definition and perturbation are

$$\begin{aligned} \dot{V} = & [-D \cos \beta + Y \sin \beta + X_T \cos \alpha \cos \beta + Y_T \sin \beta + Z_T \sin \alpha \cos \beta \\ & - mg(\sin \theta \cos \alpha \cos \beta - \cos \theta \sin \phi \sin \beta \\ & - \cos \theta \cos \phi \sin \alpha \cos \beta)]/m \end{aligned}$$

$$\begin{aligned} \dot{\alpha} = & [-L + Z_T \cos \alpha - X_T \sin \alpha + mg(\cos \theta \cos \phi \cos \alpha \\ & + \sin \theta \sin \alpha)]/Vm \cos \beta \\ & + q - \tan \beta (p \cos \alpha + r \sin \alpha) \end{aligned}$$

$$\begin{aligned} \dot{\beta} = & [D \sin \beta + Y \cos \beta - X_T \cos \alpha \sin \beta + Y_T \cos \beta - Z_T \sin \alpha \sin \beta \\ & + mg(\sin \theta \cos \alpha \sin \beta + \cos \theta \sin \phi \cos \beta \\ & - \cos \theta \cos \phi \sin \alpha \sin \beta)]/Vm \\ & + p \sin \alpha - r \cos \alpha \end{aligned}$$

The equations used to define the vehicle attitude rates are

$$\begin{aligned} \dot{\phi} &= p + q \sin \phi \tan \theta + r \cos \phi \tan \theta \\ \dot{\theta} &= q \cos \phi - r \sin \phi \\ \dot{\psi} &= q \sin \phi \sec \theta + r \cos \phi \sec \theta \end{aligned}$$

The equations used to define the earth-relative velocities are

$$\begin{aligned} \dot{h} &= V(\cos \beta \cos \alpha \sin \theta - \sin \beta \sin \phi \cos \theta - \cos \beta \sin \alpha \cos \phi \cos \theta) \\ \dot{x} &= V[\cos \beta \cos \alpha \cos \theta \cos \psi + \sin \beta (\sin \phi \sin \theta \cos \psi - \cos \phi \sin \psi) \\ & + \cos \beta \sin \alpha (\cos \phi \sin \theta \cos \psi + \sin \phi \sin \psi)] \\ \dot{y} &= V[\cos \beta \cos \alpha \cos \theta \sin \psi + \sin \beta (\sin \phi \sin \theta \sin \psi + \cos \phi \cos \psi) \\ & + \cos \beta \sin \alpha (\cos \phi \sin \theta \sin \psi - \sin \phi \cos \psi)] \end{aligned}$$

#### OBSERVATION EQUATIONS

The user-selectable observation variables computed in LINEAR represent a broad class of parameters useful for vehicle analysis and control design problems. These variables include the state, time derivatives of state, and control variables. Also included are air data parameters, accelerations, flightpath terms, and other miscellaneous parameters. The equations used to calculate those parameters are derived from a number of sources (Clancy, 1975; Dommasch and others, 1967; Etkin, 1972; Gainer and Hoffman, 1972; Gracey, 1980). Implicit in many of these observation equations is an atmospheric model. The model included in LINEAR is derived from the U.S. Standard Atmosphere (1962).

The vehicle body axis accelerations constitute the set of observation variables that, except for state variables themselves, are most commonly used in the aircraft control analysis and design problem. These accelerations are measured in g units

and are derived directly from the body axis forces defined in the previous section for translational acceleration. The body axis acceleration equations used in LINEAR are

$$a_x = (X_T - D \cos \alpha + L \sin \alpha - gm \sin \theta)/g_0 m$$

$$a_y = (Y_T + Y + gm \cos \theta \sin \phi)/g_0 m$$

$$a_z = (Z_T - D \sin \alpha - L \cos \alpha + gm \cos \theta \cos \phi)/g_0 m$$

The equations for body axis accelerometers that are at vehicle center of gravity are

$$a_{n_x} = (X_T - D \cos \alpha + L \sin \alpha)/g_0 m$$

$$a_{n_y} = (Y_T + Y)/g_0 m$$

$$a_{n_z} = (Z_T - D \sin \alpha - L \cos \alpha)/g_0 m$$

$$a_n = (-Z_T + D \sin \alpha + L \cos \alpha)/g_0 m$$

For orthogonal accelerometers that are aligned with the vehicle body axes but are not at vehicle center of gravity, the following equations apply:

$$a_{n_{x,i}} = a_{n_x} - [(q^2 + r^2)x_x - (pq - \dot{r})y_x - (pr + \dot{q})z_x]/g_0$$

$$a_{n_{y,i}} = a_{n_y} + [(pq + \dot{r})x_y - (p^2 + r^2)y_y + (qr - \dot{p})z_y]/g_0$$

$$a_{n_{z,i}} = a_{n_z} + [(pr - \dot{q})x_z + (qr + \dot{p})y_z - (q^2 + p^2)z_z]/g_0$$

$$a_{n,i} = a_n - [(pr - \dot{q})x_z + (qr + \dot{p})y_z - (q^2 + p^2)z_z]/g_0$$

where the subscripts  $x$ ,  $y$ , and  $z$  refer to the  $x$ ,  $y$ , and  $z$  body axes, respectively, and the symbols  $x$ ,  $y$ , and  $z$  refer to the  $x$ ,  $y$ , and  $z$  body axis locations of the sensors relative to the vehicle center of gravity. The symbol  $g_0$  is the acceleration due to gravity at sea level. Also included in the set of acceleration parameters is the load factor  $n = L/W$ , where  $L$  is the total aerodynamic lift and  $W$  is the vehicle weight.

The air data parameters having the greatest application to aircraft dynamics and control problems are the sensed parameters and the reference and scaling parameters. The sensed parameters are impact pressure  $q_c$ , ambient or free-stream pressure  $p_a$ , total pressure  $p_t$ , ambient or free-stream temperature  $T$ , and total temperature  $T_t$ .

The selected reference and scaling parameters are Mach number  $M$ , dynamic pressure  $\bar{q}$ , speed of sound  $a$ , Reynolds number  $Re$ , Reynolds number per unit length  $Re'$ , and the Mach meter calibration ratio  $q_c/p_a$ . These quantities are defined as

$$a = \left( 1.4 \frac{p_0}{\rho_0 T_0} T \right)^{1/2}$$

$$M = \frac{V}{a}$$

$$Re = \frac{\rho V \ell}{\mu}$$

$$Re' = \frac{\rho V}{\mu}$$

$$\bar{q} = \frac{\rho V^2}{2}$$

$$q_c = \begin{cases} [(1.0 + 0.2M^2)^{3.5} - 1.0] p_a & (M < 1.0) \\ \left[ 1.2M^2 \left( \frac{5.76M^2}{5.6M^2 - 0.8} \right)^{2.5} - 1.0 \right] p_a & (M > 1.0) \end{cases}$$

$$\frac{q_c}{p_a} = \begin{cases} (1.0 + 0.2M^2)^{3.5} - 1.0 & (M < 1.0) \\ \left[ 1.2M^2 \left( \frac{5.76M^2}{5.6M^2 - 0.8} \right)^{2.5} \right] - 1.0 & (M > 1.0) \end{cases}$$

$$P_t = p_a + q_c$$

$$T_t = T(1.0 + 0.2M^2)$$

where  $\rho$  is the density of the air,  $\mu$  is the coefficient of viscosity, and the subscript 0 refers to sea level, standard day conditions. Free-stream pressure, free-stream temperature, and the coefficient of viscosity are derived from the U.S. Standard Atmosphere (1962).

Also included in the air data calculations are two velocities: equivalent airspeed  $V_e$  and calibrated airspeed  $V_c$ , both computed in knots. The calculations assume that internal units are in the English system. The equation used for equivalent airspeed is

$$V_e = 17.17 \sqrt{\bar{q}}$$

which is derived from the definition of equivalent airspeed,

$$V_e = \sqrt{\frac{2\bar{q}}{\rho_0}}$$

where  $\rho_0 = 0.002378$  slug/ft<sup>3</sup> and  $V_e$  is converted from feet per second to knots. Calibrated airspeed is derived from the following definition of impact pressure:

$$q_c = p_o \left[ \left( 1.0 + \frac{\rho_o}{7.0 p_o} v_c^2 \right)^{3.5} - 1 \right] \quad (v_c < a_o)$$

$$q_c = 1.2 \left( \frac{v_c}{a_o} \right)^2 p_o \left[ \frac{5.76}{5.6 - 0.8 (a_o/v_c)^2} \right]^{2.5} - p_o \quad (v_c \geq a_o)$$

For the case where  $v_c < a_o$ , the equation for  $v_c$  is

$$v_c = 1479.116 \sqrt{\left( \frac{q_c}{p_o} + 1.0 \right)^{2/7} - 1.0} \quad (v_c < a_o)$$

Calibrated airspeed is found using an iterative process for the case where  $v_c \geq a_o$ . The equation

$$v_c = 582.95174 \sqrt{\left( \frac{q_c}{p_o} + 1.0 \right) \left[ 1.0 - \frac{1.0}{7.0 (v_c/a_o)^2} \right]^{2.5}} \quad (v_c \geq a_o)$$

is executed until the change in  $v_c$  from one iteration to the next is less than 0.001 knots.

Also included in the observation variables are the flightpath-related parameters (described in app. C), including flightpath angle  $\gamma$ , flightpath acceleration fpa, vertical acceleration  $\ddot{h}$ , flightpath angle rate  $\dot{\gamma}$ , and (for lack of a better category in which to place it) scaled altitude rate  $\dot{h}/57.3$ . The equations used to determine these quantities are

$$\gamma = \sin^{-1} \left( \frac{\dot{h}}{v} \right)$$

$$\text{fpa} = \frac{\dot{v}}{g_o}$$

$$\ddot{h} = a_x \sin \theta - a_y \sin \phi \cos \theta - a_z \cos \phi \cos \theta$$

$$\dot{\gamma} = \frac{v \ddot{h} - \dot{h} \dot{v}}{v \sqrt{v^2 - \dot{h}^2}}$$

Two energy-related terms are included in the observation variables: specific energy  $E_s$ , and specific power  $P_s$ , defined as

$$E_s = h + \frac{v^2}{2g}$$

$$P_s = \dot{h} + \frac{v \dot{v}}{g}$$

The set of observation variables available in LINEAR also includes four force parameters: total aerodynamic lift  $L$ , total aerodynamic drag  $D$ , total aerodynamic normal force  $N$ , and total aerodynamic axial force  $A$ . These quantities are defined as

$$L = \bar{q}SC_L$$

$$D = \bar{q}SC_D$$

$$N = L \cos \alpha + D \sin \alpha$$

$$A = -L \sin \alpha + D \cos \alpha$$

where  $C_D$  and  $C_L$  are coefficients of drag and lift, respectively.

Six body axis rates and accelerations are available as observation variables. These include the  $x$  body axis rate  $u$ , the  $y$  body axis rate  $v$ , and the  $z$  body axis rate  $w$ . Also included are the time derivatives of these quantities,  $\dot{u}$ ,  $\dot{v}$ , and  $\dot{w}$ . The equations defining these quantities are

$$u = V \cos \alpha \cos \beta$$

$$v = V \sin \beta$$

$$w = V \sin \alpha \cos \beta$$

$$\dot{u} = \left( \frac{X_T - gm \sin \theta - D \cos \alpha + L \sin \alpha}{m} \right) + rv - qw$$

$$\dot{v} = \left( \frac{Y_T + gm \cos \theta \sin \phi + Y}{m} \right) + pw - ru$$

$$\dot{w} = \left( \frac{Z_T + gm \cos \theta \cos \phi - D \sin \alpha - L \cos \alpha}{m} \right) + qu - pv$$

The final set of observation variables available in LINEAR is a miscellaneous collection of other parameters of interest in analysis and design problems. The first group consists of measurements from sensors not located at the vehicle center of gravity. These represent angle of attack  $\alpha_i$ , angle of sideslip  $\beta_i$ , altitude  $h_i$ , and altitude rate  $\dot{h}_i$  measurements displaced from the center of gravity by some  $x$ ,  $y$ , and  $z$  body axis distances. The equations used to compute these quantities are

$$\alpha_i = \alpha - \left( \frac{qx - py}{V} \right)$$

$$\beta_i = \beta + \left( \frac{rx - pz}{V} \right)$$

$$h_i = h + x \sin \theta - y \sin \phi \cos \theta - z \cos \phi \cos \theta$$



$$\dot{h}_{,i} = \dot{h} + \dot{\theta}(x \cos \theta + y \sin \phi \sin \theta + z \cos \phi \sin \theta) \\ - \dot{\phi}(y \cos \phi \cos \theta - z \sin \phi \cos \theta)$$

The remaining miscellaneous parameters are total angular momentum  $T$ , stability axis roll rate  $p_s$ , stability axis pitch rate  $q_s$ , and stability axis yaw rate  $r_s$ , defined as

$$T = \frac{1}{2}(I_x p^2 - 2I_{xy}pq - 2I_{xz}pr + I_y q^2 - 2I_{yz}qr + I_z r^2)$$

$$p_s = p \cos \alpha + r \sin \alpha$$

$$q_s = q$$

$$r_s = -p \sin \alpha + r \cos \alpha$$

#### SELECTION OF STATE, CONTROL, AND OBSERVATION VARIABLES

The equations in the two preceding sections define the state and observation variables available in LINEAR. The control variables are defined by the user in the input file. Internally, the program uses a 12-state model, a 120-variable observation vector, and a 30-parameter control vector. These variables can be selected to specify the formulation most suited for the specific application. The order and number of parameters in the output model are completely under user control. Figure 1 shows the selection of variables for the state vector of the output model. However, it should be noted that no model order reduction is attempted. Elements of the matrices in the internal formulation are simply selected and reordered in the formulation specified by the user.

Specific state, control, and observation variables for the formulation of the output matrices are selected by alphanumeric descriptors in the input file. The use of these alphanumeric descriptors is described in the Data Input section. Appendix C lists the observation variables and their alphanumeric descriptors. Appendix D lists the state variables and their alphanumeric descriptors. The alphanumeric descriptors for the selection of control parameters to be included in the observation vector are the control variable names defined by the user in the input file, as described in the Input Files section.

#### LINEAR MODELS

The linearized system matrices computed by LINEAR are the first-order terms of a Taylor series expansion about the analysis point (Dieudonne, 1978; Kwakernaak and Sivan, 1972; NASA RP by Duke, Antoniewicz, and Krambeer) and are assumed to result in a time-invariant linear system. The validity of this assumption is discussed in the

Analysis Point Definition section. The technique used to obtain these matrices numerically is a simple approximation to the partial derivative, that is,

$$\frac{\partial f}{\partial x} \approx \frac{f(x_0 + \Delta x) - f(x_0 - \Delta x)}{2 \Delta x}$$

where  $f$  is a general function of  $x$ , an arbitrary independent variable. The  $\Delta x$  may be set by the user, but defaults to 0.001 for all state and control parameters, with the single exception of velocity  $V$ , where  $\Delta x$  is multiplied by  $a$ , the speed of sound, to obtain a reasonable perturbation size.

From the generalized nonlinear state equation

$$T\dot{x} = f(x, \dot{x}, u)$$

and the observation equation

$$y = g(x, \dot{x}, u)$$

the program determines the linearized matrices for the generalized formulation of the system:

$$C \delta \dot{x} = A' \delta x + B' \delta u$$

$$\delta y = H' \delta x + G \delta \dot{x} + F' \delta u$$

where

$$C = T - \frac{\partial f}{\partial \dot{x}}$$

$$A' = \frac{\partial f}{\partial x}$$

$$B' = \frac{\partial f}{\partial u}$$

$$H' = \frac{\partial g}{\partial x}$$

$$G = \frac{\partial g}{\partial \dot{x}}$$

$$F' = \frac{\partial g}{\partial u}$$

with all derivatives evaluated along the nominal trajectory defined by the analysis point  $(\mathbf{x}_0, \dot{\mathbf{x}}_0, \mathbf{u}_0)$ . The state, time derivative of state, and control vectors can be expressed as small perturbations about the nominal trajectory, so that

$$\mathbf{x} = \mathbf{x}_0 + \delta\mathbf{x}$$

$$\dot{\mathbf{x}} = \dot{\mathbf{x}}_0 + \delta\dot{\mathbf{x}}$$

$$\mathbf{u} = \mathbf{u}_0 + \delta\mathbf{u}$$

In addition to the matrices for this generalized system, the user has the option of requesting linearized matrices for a standard formulation of the system:

$$\delta\dot{\mathbf{x}} = \mathbf{A} \delta\mathbf{x} + \mathbf{B} \delta\mathbf{u}$$

$$\delta\mathbf{y} = \mathbf{H} \delta\mathbf{x} + \mathbf{F} \delta\mathbf{u}$$

where

$$\mathbf{A} = \left[ \mathbf{T} - \frac{\partial \mathbf{f}}{\partial \dot{\mathbf{x}}} \right]^{-1} \frac{\partial \mathbf{f}}{\partial \mathbf{x}}$$

$$\mathbf{B} = \left[ \mathbf{T} - \frac{\partial \mathbf{f}}{\partial \dot{\mathbf{x}}} \right]^{-1} \frac{\partial \mathbf{f}}{\partial \mathbf{u}}$$

$$\mathbf{H} = \frac{\partial \mathbf{g}}{\partial \mathbf{x}} + \frac{\partial \mathbf{g}}{\partial \dot{\mathbf{x}}} \left[ \mathbf{T} - \frac{\partial \mathbf{f}}{\partial \dot{\mathbf{x}}} \right]^{-1} \frac{\partial \mathbf{f}}{\partial \mathbf{x}}$$

$$\mathbf{F} = \frac{\partial \mathbf{g}}{\partial \mathbf{u}} + \frac{\partial \mathbf{g}}{\partial \dot{\mathbf{x}}} \left[ \mathbf{T} - \frac{\partial \mathbf{f}}{\partial \dot{\mathbf{x}}} \right]^{-1} \frac{\partial \mathbf{f}}{\partial \mathbf{u}}$$

with all derivatives evaluated along the nominal trajectory defined by the analysis point  $(\mathbf{x}_0, \dot{\mathbf{x}}_0, \mathbf{u}_0)$ .

LINEAR also provides two nonstandard matrices, D and E, in the equations

$$\dot{\mathbf{x}} = \mathbf{A}\mathbf{x} + \mathbf{B}\mathbf{u} + \mathbf{D}\mathbf{v}$$

$$\mathbf{y} = \mathbf{H}\mathbf{x} + \mathbf{F}\mathbf{u} + \mathbf{E}\mathbf{v}$$

or D' and E' in the equations

$$\mathbf{C}\dot{\mathbf{x}} = \mathbf{A}'\mathbf{x} + \mathbf{B}'\mathbf{u} + \mathbf{D}'\mathbf{v}$$

$$\mathbf{y} = \mathbf{H}'\mathbf{x} + \mathbf{G}\dot{\mathbf{x}} + \mathbf{F}'\mathbf{u} + \mathbf{E}'\mathbf{v}$$

These dynamic interaction matrices include the effect of external forces and moments acting on the vehicle. The components of the dynamic interaction vector  $\mathbf{v}$  are incremental body axis forces and moments:

$$\mathbf{v} = \begin{bmatrix} \delta X \\ \delta Y \\ \delta Z \\ \delta L \\ \delta M \\ \delta N \end{bmatrix}$$

Thus,

$$D' = \frac{\partial \mathbf{f}}{\partial \mathbf{v}}$$

$$E' = \frac{\partial \mathbf{g}}{\partial \mathbf{v}}$$

and

$$D = \left[ T - \frac{\partial \mathbf{f}}{\partial \mathbf{x}} \right]^{-1} \frac{\partial \mathbf{f}}{\partial \mathbf{v}}$$

$$E = \frac{\partial \mathbf{g}}{\partial \mathbf{v}} + \frac{\partial \mathbf{g}}{\partial \mathbf{x}} \left[ T - \frac{\partial \mathbf{f}}{\partial \mathbf{x}} \right]^{-1} \frac{\partial \mathbf{f}}{\partial \mathbf{v}}$$

These matrices allow the effects of unusual subsystems or control effectors to be easily included in the vehicle dynamics.

The default output matrices for LINEAR are those for the standard system formulation. However, the user can select matrices for either generalized or standard state and observation equations in any combination. Internally, the matrices are computed for the generalized system formulation and then combined appropriately to accommodate the system formulation requested by the user.

#### ANALYSIS POINT DEFINITION

The point at which the nonlinear system equations are linearized is referred to as the analysis point. This can represent a true steady-state condition on the specified trajectory (a point at which the rotational and translational accelerations are zero; Perkins and Hage, 1949; Thelander, 1965) or a totally arbitrary state on a trajectory. LINEAR allows the user to select from a variety of analysis points. These analysis points are referred to as trim conditions, and several options are available to the user. The arbitrary state and control option is designated NOTRIM, and in selecting this option the user must specify all nonzero state and control variables. For the equilibrium conditions, the user specifies a minimum number of parameters, and the program numerically determines required state and control variables to force

the rotational and translational accelerations to zero. The analysis point options are described in detail in the following subsections.

For all the analysis point definition options, any state or control parameter may be input by the user. Those state variables not required to define the analysis point are used as initial estimates for the calculation of the state and control conditions that result in zero rotational and translational accelerations. As each state variable is read into LINEAR, the name is compared to the list of alternative state variable names listed in appendix D. All state variables except velocity must be specified according to this list. Velocity can also be defined by specifying Mach number (see alternative observation variable names in appendix C). Appendix E lists analysis point definition identifiers that are recognized by LINEAR.

It should be noted that the option of allowing the user to linearize the system equations about a nonequilibrium condition raises theoretical issues (beyond the scope of this report) the potential user should be aware of. Although all the analysis point definition options provided in LINEAR have been found to be useful in the analysis of vehicle dynamics, not all the linear models derived about these analysis points result in the time-invariant systems assumed in this report. However, the results of the linearization provided by LINEAR do give the appearance of being time invariant.

The linearization process as defined in this report is always valid for some time interval beyond the point in the trajectory about which the linearization is done. However, for the resultant system to be truly time invariant, the vehicle must be in a sustainable, steady-state flight condition. This requirement is something more than merely a trim requirement, which is typically represented as  $\dot{\mathbf{x}}(t) = 0$ , indicating that for trim, all the time derivatives of the state variables must be zero. (This is not the case, however: Trim is achieved when the acceleration-like terms are identically zero; no constraints need to be placed on the velocity-like terms in  $\dot{\mathbf{x}}$ . Thus, for the model used in LINEAR, only  $\dot{p}$ ,  $\dot{q}$ ,  $\dot{r}$ ,  $\dot{V}$ ,  $\dot{\alpha}$ , and  $\dot{\beta}$  must be zero to satisfy the trim condition.) The trim condition is achieved for the straight-and-level, pushover-pullup, level turn, thrust-stabilized turn, and beta trim options described in the following sections. In general, the untrimmed and specific power analysis point definition options do not result in a trim condition.

Of these analysis point options resulting in a trim condition, only the straight-and-level and level turn options force the model to represent sustainable flight conditions. In fact, only in the special case where the flightpath angle is zero does a truly sustainable trim occur.

As previously stated, the linearization of a nonlinear model and its representation as a time-invariant system are always valid for some time interval beyond the analysis point on the trajectory. This time interval is determined by several factors (such as trim and sustainable flight conditions) and ultimately by accuracy requirements placed on the representation. Thus, in using the linear models provided by this program, the user should exercise some caution.

#### Untrimmed

For the untrimmed analysis point, the user specifies all state and control variables that are to be set at some value other than zero. The number of state var-

ables specified is entirely at the user's discretion. If any of the control variables are to be nonzero, the user must specify the control parameter and its value. The untrimmed option allows the user to analyze the vehicle dynamics at any flight condition, including transitory conditions.

### Straight-and-Level Trim

The straight-and-level analysis points available in LINEAR are in fact wings-level, constant-flightpath-angle trims. Both options available for straight-and-level trim allow the user to specify either a flightpath angle or an altitude rate. However, since the default value for these terms is zero, the default for both types of straight-and-level trim is wings-level, horizontal flight.

The two options available for straight-and-level trim require the user to specify altitude and either an angle of attack or a Mach number. If a specific angle of attack and altitude combination is desired, the user selects the "Mach-trim" option, which determines the velocity required for the requested trajectory. Likewise, the "alpha-trim" option allows the user to specify Mach number and altitude, and the trim routines in LINEAR determine the angle of attack needed for the requested trajectory.

The trim condition for both straight-and-level options is determined within the following constraints:

$$p = q = r = 0$$

$$\phi = 0$$

The trim surface positions, thrust, angle of sideslip, and either velocity or angle of attack are determined by numerically solving the nonlinear equations for the translational and rotational acceleration. Pitch attitude  $\theta$  is determined by iterative solution of the altitude rate equation.

### Pushover-Pullup

The pushover-pullup analysis points result in wings-level flight at  $n \neq 1$ . For  $n > 1$ , the analysis point is the minimum altitude point of a pullup when  $\dot{h} = 0$ . For  $n < 1$ , this trim results in a pushover at the maximum altitude with  $\dot{h} = 0$ . There are two options available for the pushover-pullup analysis point definition: (1) the "alpha-trim" option in which angle of attack is determined from the specified altitude, Mach number, and load factor, and (2) the "load-factor-trim" option in which angle of attack, altitude, and Mach number are specified, and load factor is determined according to the constraint equations.

The analysis point is determined at the specified conditions, subject to the following constraints:

$$p = r = 0$$

$$q = \frac{1}{V_m \cos \beta} [mg(n - \cos(\theta - \alpha)) - Z_T \cos \alpha + X_T \sin \alpha]$$

$$\phi = 0$$

The expression for  $q$  is derived from the  $\dot{\alpha}$  equation by setting  $\dot{\alpha} = 0$  and  $\phi = 0$ ;  $\theta$  is derived from the  $\dot{h}$  equation. The trim surface positions, thrust, angle of sideslip, and either angle of attack or load factor are determined by numerically solving the nonlinear equations for the translational and rotational accelerations.

### Level Turn

The level turn analysis point definition options result in nonwings-level, constant-turn-rate flight at load factors greater than one. The vehicle model is assumed to have sufficient excess thrust to trim at the condition specified. If thrust is not sufficient, trim will not result, and the analysis point thus defined will have a nonzero (in fact, negative) velocity rate.

The level trim options available in LINEAR require the specification of an altitude and a Mach number. The user can then use either angle of attack or load factor to define the desired flight condition. These two options are referred to as "alpha-trim" and "load-factor-trim," respectively. For either option, the user may also request a specific flightpath angle or altitude rate. Thus, these analysis point definitions may result in ascending or descending spirals, although the default is for the constant-altitude turn.

The constraint equations for the coordinated level turn analysis point definitions are derived by Chen (1981), and Chen and Jeske (1981). Using the requested load factor, the tilt angle of acceleration normal to the flightpath from the vertical plane  $\phi_L$  is calculated using the equation

$$\phi_L = \pm \tan^{-1} \left[ \frac{(n^2 - \cos^2 \gamma)^{1/2}}{\cos \gamma} \right]$$

where the positive sign is used for a right turn and the negative sign is used for a left turn. From  $\phi_L$ , turn rate can be calculated as

$$\dot{\psi} = \frac{g}{V} \tan \phi_L$$

Using these two definitions, the state variables can be determined:

$$q = \dot{\psi} \sin^2 \phi_L \left[ -\sin \gamma \sin \beta \pm \left( \sin^2 \gamma \sin^2 \beta - \frac{\sin^2 \gamma - \cos^2 \beta}{\sin^2 \phi_L} \right)^{1/2} \right]$$

$$r_s = \frac{q}{\tan \phi_L \cos \beta}$$

$$p_s = -\frac{\dot{\psi} \sin \gamma}{\cos \beta} - q \tan \beta$$

$$p = p_s \cos \alpha - r_s \sin \alpha$$

$$r = p_s \sin \alpha + r_s \cos \alpha$$

$$\theta = \sin^{-1}(-p/\dot{\psi})$$

$$\phi = \tan^{-1}(q/r)$$

The trim surface positions, thrust, angle of sideslip, and either angle of attack or load factor are determined by numerically solving the nonlinear equations for the translational and rotational accelerations.

#### Thrust-Stabilized Turn

The thrust-stabilized turn analysis point definition results in a constant throttle nonwings-level turn with a nonzero altitude rate. The two options available in LINEAR are "alpha-trim" and "load-factor-trim." These options allow the user to specify either the angle of attack or the load factor for the analysis point. The altitude and Mach number at the analysis point must be specified for both options. The user also must specify the value of the thrust trim parameter by assigning a value to the variable THRSTX in the input file after the trim has been selected.

The constraint equations for the thrust-stabilized turn are the same as those for the level turn. However, for this analysis point definition, flightpath angle is determined by LINEAR.

#### Beta Trim

The beta trim analysis point definition results in nonwings-level, horizontal flight with the heading rate  $\dot{\psi}$  equal to zero at a user-specified Mach number, altitude, and angle of sideslip. This trim option is nominally at 1 g, but as  $\beta$  and  $\phi$  vary from zero, normal acceleration decreases and lateral acceleration increases. For an aerodynamically symmetric aircraft, a trim to  $\beta = 0$  using the beta trim option results in the same trimmed condition as the straight-and-level trim. However, for an aerodynamically asymmetric aircraft, such as an oblique-wing vehicle, the two trim options are not equivalent.

The constraint equations used with the beta trim option are

$$p = q = r = 0$$

The trim surface positions, thrust, angle of attack, and bank angle are determined by numerically solving the nonlinear equations for translational and rotational acceleration. Pitch attitude  $\theta$  is derived from the equation for flightpath angle  $\gamma$  with  $\gamma = 0$  and is defined as

$$\theta = \tan^{-1} \left( \frac{\sin \beta \sin \phi + \cos \beta \sin \alpha}{\cos \beta \cos \alpha} \right)$$

#### Specific Power

The specific power analysis point definition results in a level turn at a user-specified Mach number, altitude, thrust trim parameter, and specific power. Unlike



the other trim options provided in LINEAR, the specific power option does not, in general, attempt to achieve the zero velocity rate  $\dot{V}$ . In fact, because the altitude rate  $\dot{h} = 0$  and specific power are defined by

$$P_S = \dot{h} + \frac{V\dot{V}}{g}$$

the resultant velocity rate will be

$$\dot{V} = \frac{P_S g}{V}$$

However, the other acceleration-like terms ( $\dot{p}$ ,  $\dot{q}$ ,  $\dot{r}$ ,  $\dot{\alpha}$ , and  $\dot{\beta}$ ) will be zero if the requested analysis point is achieved.

The constraint equations used with the specific power analysis point definition option can be derived from the load factor tilt angle equation used in the level turn analysis point definition with  $\gamma = 0$ :

$$\phi_L = \pm \tan^{-1}(n^2 - 1)^{1/2}$$

(where the positive sign is used for a right turn and the negative sign is used for a left turn),

$$\dot{\psi} = \frac{g}{V} \tan \phi_L$$

$$q = \dot{\psi} \sin \phi_L \cos \beta$$

$$r_S = \frac{g}{\tan \phi_L \cos \beta}$$

$$p_S = -q \tan \beta$$

$$p = p_S \cos \alpha - r_S \sin \alpha$$

$$r = p_S \sin \alpha + r_S \cos \alpha$$

$$\theta = \sin^{-1} \left( -\frac{p}{\dot{\psi}} \right)$$

$$\phi = \tan^{-1} \frac{q}{r}$$

The analysis point surface positions, load factor, angle of attack, and angle of sideslip are determined by numerically solving the nonlinear equations for translational and rotational acceleration.

## NONDIMENSIONAL STABILITY AND CONTROL DERIVATIVES

The nondimensional stability and control derivatives computed by LINEAR from the nonlinear aerodynamic model assume broadly formulated linear aerodynamic equations. These equations include effects of what are normally considered exclusively lateral-directional parameters in the longitudinal force and moment coefficient equations, and, conversely, effects of longitudinal parameters in the lateral-directional equations. The reason for this is two-fold: application to a larger class of vehicle types, such as oblique-wing aircraft, and computational ease.

The nondimensional stability and control derivatives assume the following equations for the aerodynamic force and moment coefficients:

$$C_L = C_{L_0} + C_{L_\alpha} \alpha + C_{L_\beta} \beta + C_{L_h} \delta h + C_{L_V} \delta V + \sum_{i=1}^n C_{L_{\delta_i}} \delta_i$$

$$+ C_{L_p} \hat{p} + C_{L_q} \hat{q} + C_{L_r} \hat{r} + C_{L_{\dot{\alpha}}} \hat{\dot{\alpha}} + C_{L_{\dot{\beta}}} \hat{\dot{\beta}}$$

$$C_m = C_{m_0} + C_{m_\alpha} \alpha + C_{m_\beta} \beta + C_{m_h} \delta h + C_{m_V} \delta V + \sum_{i=1}^n C_{m_{\delta_i}} \delta_i$$

$$+ C_{m_p} \hat{p} + C_{m_q} \hat{q} + C_{m_r} \hat{r} + C_{m_{\dot{\alpha}}} \hat{\dot{\alpha}} + C_{m_{\dot{\beta}}} \hat{\dot{\beta}}$$

$$C_n = C_{n_0} + C_{n_\alpha} \alpha + C_{n_\beta} \beta + C_{n_h} \delta h + C_{n_V} \delta V + \sum_{i=1}^n C_{n_{\delta_i}} \delta_i$$

$$+ C_{n_p} \hat{p} + C_{n_q} \hat{q} + C_{n_r} \hat{r} + C_{n_{\dot{\alpha}}} \hat{\dot{\alpha}} + C_{n_{\dot{\beta}}} \hat{\dot{\beta}}$$

$$C_L = C_{L_0} + C_{L_\alpha} \alpha + C_{L_\beta} \beta + C_{L_h} \delta h + C_{L_V} \delta V + \sum_{i=1}^n C_{L_{\delta_i}} \delta_i$$

$$+ C_{L_p} \hat{p} + C_{L_q} \hat{q} + C_{L_r} \hat{r} + C_{L_{\dot{\alpha}}} \hat{\dot{\alpha}} + C_{L_{\dot{\beta}}} \hat{\dot{\beta}}$$

$$C_D = C_{D_0} + C_{D_\alpha} \alpha + C_{D_\beta} \beta + C_{D_h} \delta h + C_{D_V} \delta V + \sum_{i=1}^n C_{D_{\delta_i}} \delta_i$$

$$+ C_{D_p} \hat{p} + C_{D_q} \hat{q} + C_{D_r} \hat{r} + C_{D_{\dot{\alpha}}} \hat{\dot{\alpha}} + C_{D_{\dot{\beta}}} \hat{\dot{\beta}}$$

$$C_Y = C_{Y_0} + C_{Y_\alpha} \alpha + C_{Y_\beta} \beta + C_{Y_h} \delta_h + C_{Y_V} \delta V + \sum_{i=1}^n C_{Y_{\delta_i}} \delta_i$$

$$+ C_{Y_p} \hat{p} + C_{Y_q} \hat{q} + C_{Y_r} \hat{r} + C_{Y_{\dot{\alpha}}} \dot{\alpha} + C_{Y_{\dot{\beta}}} \dot{\beta}$$

where the stability and control derivatives have the usual meaning,

$$C_{\epsilon_x} \equiv \frac{\partial C_\epsilon}{\partial x}$$

with  $C_\epsilon$  being an arbitrary force or moment coefficient and  $x$  an arbitrary nondimensional variable. The rotational terms in the equations are nondimensional versions of the corresponding state variable with

$$\hat{p} = \frac{bp}{2V}$$

$$\hat{q} = \frac{cq}{2V}$$

$$\hat{r} = \frac{br}{2V}$$

$$\dot{\alpha} = \frac{\dot{\alpha}}{2V}$$

$$\dot{\beta} = \frac{\dot{\beta}}{2V}$$

The  $\delta_i$  in the summations are the  $n$  control variables defined by the user. The effects of altitude and velocity are included in the derivatives with respect to those parameters and in the incremental multipliers

$$\delta h = h - h_0$$

$$\delta V = V - V_0$$

where the subscript zero represents the current analysis point  $(x_0, \dot{x}_0, u_0)$ , described in the Analysis Point Definition section.

All stability derivatives are computed as nondimensional terms except the altitude and velocity parameters. The units of the control derivatives correspond to the units used in the nonlinear aerodynamic model. LINEAR is capable of handling both Mach and velocity derivatives. Using the equation

$$C_{\epsilon_M} = C_{\epsilon_V} a_h$$

(where  $a_h$  is the speed of sound at the reference altitude), LINEAR will compute the Mach derivatives from the velocity derivatives or vice versa. Internally, however,

LINEAR uses velocity derivatives in the computations of the total force and moment coefficients. Derivatives with respect to angle of attack and angle of sideslip can be obtained in units of reciprocal degrees. These derivatives are simply the corresponding nondimensional derivatives multiplied by  $180/\pi$ .

#### DATA INPUT

The interactive linearizer allows the user to input data in various manners:

1. All input data can be loaded from a single file (either a file assigned to logical unit 1 or any file named with 10 characters or less);
2. Data can be separated onto different files, each containing different sections of data;
3. Data can be typed in from the terminal; or
4. A combination of (2) and (3).

#### Input Files

The interactive LINEAR input file (defined in table 1) is separated into six major sections: vehicle title information; geometry and mass data for the aircraft; state, control, and observation variable definitions for the state-space model; the trim parameter specification; additional control surfaces that may be specified for each case; and various test case specifications. All the input data can be written on one file or various files according to the divisions specified at the beginning of this paragraph and according to the input format defined in table 1. An example input file is listed in appendix F. All the input records to LINEAR are written in ASCII form.

#### Title Information

There is one title record that needs to be specified for interactive LINEAR: the name of the specific vehicle. This record is read with a 20A4 format. The vehicle title appears on each page of the line printer output file.

#### Geometry and Mass Data

The geometry and mass data consist of four records that either can follow the vehicle title, exist as a file on its own, or be input interactively from the terminal. If it is input from the terminal, then it will be stored either on the same file as the vehicle title, or on a separate file. The geometry and mass data records define the geometry, mass properties, location of the aerodynamic reference point with respect to the center of gravity, and angle-of-attack range for the vehicle model being analyzed.

TABLE 1. -- INPUT FORMAT FOR LINEAR

Input record	Format
VEHICLE TITLE	(20A4)
S      b $\bar{c}$ Weight	(4F13.0)
I <sub>x</sub> I <sub>y</sub> I <sub>z</sub> I <sub>xz</sub> I <sub>xy</sub> I <sub>yz</sub>	(6F13.0)
DELX                    DELY                    DELZ                    LOGCG	(3F10.0,12A4)
$\alpha_{min}$ $\alpha_{max}$	(2F13.0)
NUMSAT                    EQUAT                    STAB	(I10,A4,11X,A4)
STATE 1                    DRVINC 1	(5A4,F10.0)
STATE 2                    DRVINC 2	(5A4,F10.0)
STATE 3                    DRVINC 3	(5A4,F10.0)
.	.
.	.
.	.
NUMSUR	(I10)
CONTROL 1                    LOCCNT 1                    CONVR 1                    CNTINC 1	(5A4,I10,A4,6X,F10.0)
CONTROL 2                    LOCCNT 2                    CONVR 2                    CNTINC 2	(5A4,I10,A4,6X,F10.0)
CONTROL 3                    LOCCNT 3                    CONVR 3                    CNTINC 3	(5A4,I10,A4,6X,F10.0)
.	.
.	.
.	.
.	.
NUMYVC                    EQUAT	(I10,A4)
MEASUREMENT 1                    PARAM 1 (1-3)	(5A4,3F10.0)
MEASUREMENT 2                    PARAM 2 (1-3)	(5A4,3F10.0)
MEASUREMENT 3                    PARAM 3 (1-3)	(5A4,3F10.0)
.	.
.	.
.	.
.	.
$\delta_{emin}$ $\delta_{emax}$ $\delta_{amin}$ $\delta_{amax}$ $\delta_{rmin}$ $\delta_{rmax}$ $\delta_{thmin}$ $\delta_{thmax}$	(8F10.0)
NUMXSR	(1X,I2)
ADDITIONAL SURFACE 1                    LOCCNT 1                    CONVR1	(5A4,I10,A4)
ADDITIONAL SURFACE 2                    LOCCNT 2                    CONVR2	(5A4,I10,A4)
ADDITIONAL SURFACE 3                    LOCCNT 3                    CONVR3	(5A4,I10,A4)
.	.
.	.
.	.
ANALYSIS POINT DEFINITION OPTION	(20A4)
ANALYSIS POINT DEFINITION SUBOPTION	(A4)
VARIABLE 1                    VALUE 1	(5A4,F15.5)
VARIABLE 2                    VALUE 2	(5A4,F15.5)
VARIABLE 3                    VALUE 3	(5A4,F15.5)
.	.
.	.
.	.
.	.

TABLE 1. - Concluded

Input record	Format
NEXT	(A4)
ANALYSIS POINT DEFINITION OPTION	(20A4)
ANALYSIS POINT DEFINITION SUBOPTION	(A4)
VARIABLE 1        VALUE 1	(5A4,F15.5)
VARIABLE 2        VALUE 2	(5A4,F15.5)
VARIABLE 3        VALUE 3	(5A4,F15.5)
.                    .	.
.                    .	.
.                    .	.
.                    .	.
END	(A4)

The first and second records describe the vehicle geometry, mass, and mass distribution. The first record defines the wing planform area  $S$  in units of feet squared; the wingspan  $b$  in units of feet; the mean aerodynamic chord of the wing  $\bar{c}$  in units of feet; and the sea level weight of the vehicle  $Weight$ , in units of pounds. The second record defines the vehicle moments and products of inertia in units of slug-feet squared. The third record defines the offset of the aerodynamic reference point with respect to the vehicle center of gravity in the normal right-handed body axis reference system with the positive  $x$  axis forward. The format of the data can be seen in table 1 with  $DELX$ ,  $DELY$ , and  $DELZ$  representing the  $x$ ,  $y$ , and  $z$  body axis displacements of the aerodynamic reference point with respect to the center of gravity in units of feet (see app. A). The fourth variable of the third record is an alphanumeric variable, read using a 12A4 format, to specify if corrections due to a center-of-gravity offset are to be computed in  $LINEAR$  or in the user-supplied aerodynamic subroutine  $CCALC$ . The variable  $LOGCG$  defaults to a state that causes the aerodynamic reference point offset calculations to be performed by subroutines within  $LINEAR$ . Any of the following statements in the  $LOGCG$  field will cause  $LINEAR$  not to make these corrections:

NO CG CORRECTIONS BY  $LINEAR$

$CCALC$  WILL CALCULATE CG CORRECTIONS

FORCE AND MOMENT CORRECTIONS CALCULATED IN  $CCALC$

However,  $LINEAR$  will read only the first four characters of the string.

The final record of this geometry and mass data set defines the angle-of-attack range for which the user-supplied nonlinear aerodynamic model ( $CCALC$ ) is valid. The parameters  $\alpha_{min}$  and  $\alpha_{max}$  specify the minimum and maximum values of angle of attack to be used for trimming the aircraft model. These parameters are in units of degrees.

#### State, Control, and Observation Variable Definitions

The state, control, and observation variables to be used in the output formulation of the linearized system are defined in records that either follow the last of the previously described sets of records on the same file, are stored on a separate file, or are input through the terminal. If they are input through the terminal, they will be stored in a file specified by the user. The number of records in the state, control, and observation variable definition set is determined by the number of such variables defined by the user.

The states to be used in the output formulation of the linearized system are defined in the first set of records in the state, control, and observation variable definitions. The first record of this set, as shown in table 1, defines the number of states to be used ( $NUMSAT$ ), the formulation of the state equation ( $EQUAT$ ), and whether the nondimensional stability derivatives with respect to angle of attack and angle of sideslip are to be output in units of reciprocal radians or degrees. The variable  $EQUAT$  is read using an A4 format and is tested against the following list:

NONSTANDARD  
NON-STANDARD  
GENERALIZED  
EXTENDED

If EQUAT matches the first four characters of any of the listed words, the output formulation of the state equation is

$$C\dot{x} = A'x + B'u$$

If EQUAT is read in as STANDARD or does not match the preceding list, then the default standard bilinear formulation of the state equation is assumed, and the output matrices are consistent with the equation

$$\dot{x} = Ax + Bu$$

The variable STAB is also read using an A4 format and is compared with the following list:

DEGREES  
DGR

If STAB matches the first four characters of either of these words, the nondimensional stability derivatives with respect to angle of attack and angle of sideslip are printed in units of reciprocal degrees on the printer file. Otherwise, these derivatives are printed in units of reciprocal radians.

The remaining records of the state variable definition set are used to specify the state variables to be used in the output formulation of the linearized system and the increments to be used for the numerical perturbation described in the Linear Models section. The state variable names are checked for validity against the state variable alphanumeric descriptors listed in appendix D. If a name is not recognized, the variable is ignored and a warning message is written to the printer file. The increment to be used with any state variable (in calculating the A' and H' matrices) and the time derivative of that state variable (in calculating the C and G matrices) can be specified using the DRVINC variable. The DRVINC specified for velocity will be multiplied by the speed of sound within LINEAR in order to scale up the perturbation size to a reasonable value while keeping DRVINC on the same order of magnitude as for the other states. If DRVINC is not specified by the user, the default value of 0.001 is used.

The next set of records in the state, control, and observation variable definitions are those defining the variables to be used in the control vector of the output model. The first record of this set defines the number of control parameters to be used (NUMSUR). The remaining records define the names of these variables (CONTROL), their location (LOCNT) in the common block /CONTRL/ (see the User-Supplied Subroutines section), the units associated with these control variables (CONVR), and the increments (CNTINC) to be used with these variables in determining the B' and F' matrices.

Because LINEAR has no default control variable names, the control variable names input by the user are used for subsequent identification of the control variables. Therefore, consistency in the use of control variable names is extremely important,



particularly when the user attempts to establish control variable initial conditions when using the untrimmed analysis point definition option.

The CONVR field in the control variable records is used to specify if the control variables are given in degrees or radians. CONVR is read using an A4 format and is compared to the following list:

DEGREES  
DGR  
RADIANS  
RAD

If CONVR agrees with the first four characters of either of the first two names, it is assumed that the control variable is specified in units of degrees. If CONVR agrees with the first four characters of either of the last two listed names, it is assumed that the control variable is specified in units of radians. No units are assumed if CONVR does not agree with any of the listed names. When it is assumed that the control variable is specified in units of radians, the initial value of the control variable is converted to degrees before being written to the printer file.

The variable CNTINC can be used to specify the increments used for a particular control surface when the B' and F' matrices are being calculated. It is assumed that the units of CNTINC agree with those used for the surface, and no unit conversion is attempted on these increments. If CNTINC is not specified for a particular surface, a default value of 0.001 is used.

The final set of records in the state, control, and observation variable definitions pertain to the specification of parameters associated with the observation vector, observation equation, and observation parameters. The first record of this set defines the number of observation variables (NUMYVC) to be used in the output linear model and the formulation of the output equation (EQUAT). The remaining records in this set specify the variables to be included in the observation vector (MEASUREMENT) and any position information (PARAM) that may be required to compute the output model for a sensor not located at the vehicle center of gravity.

The variable used to specify the formulation of the observation equation (EQUAT) is compared with the same list of names used to determine the formulation of the state equation. If it is determined that the generalized formulation is desired, the observation equation

$$y = H'x + G\dot{x} + F'u$$

is used. Otherwise, the standard formulation is assumed, and the form of the observation equation used is

$$y = Hx + Fu$$

The records defining the observation variables to be used in the output formulation of the linear model contain a variable that includes the parameter name (MEASUREMENT) and three fields (PARAM) defining, when appropriate, the location of the sensor relative to the vehicle center of gravity. The parameter name is compared with the list of observation variables given in appendix D. If the parameter name is recognized as a valid observation variable name, that observation variable is

included in the formulation of the output observation vector. If the parameter name is not recognized, an error message is printed and the parameter named is ignored. The three variables represented by PARAM(1), PARAM(2), and PARAM(3) provide the x-axis, y-axis, and z-axis locations, respectively, of the measurement with respect to the vehicle center of gravity if the selected observation is one of the following:

$a_{x,i}$

$a_{y,i}$

$a_{z,i}$

$a_{n,i}$

$h_{,i}$

$\dot{h}_{,i}$

$\alpha_{,i}$

$\beta_{,i}$

The unit associated with these variables is feet. If the selected observation variable is not in the preceding list, the PARAM variables are not used. The sole exception to this occurs when Reynolds number is requested as an observation variable. In that case, PARAM(1) is used to specify the characteristic length. When no value is input for PARAM(1), the mean aerodynamic chord  $\bar{c}$  is used as the characteristic length.

#### Trim Parameter Specification

There is one record in the trim parameter specification set that is associated with the subroutine UCNTL (described in the User-Supplied Subroutines section). This record specifies the limits to be used for the trim parameters  $\delta_e$ ,  $\delta_a$ ,  $\delta_r$ , and  $\delta_{th}$ , representing the longitudinal, lateral, directional, and thrust trim parameters, respectively. The units associated with these parameters are defined by the implementation of UCNTL.

#### Additional Surface Specification

The first record of the set of additional surface specifications defines the number of additional controls to be included in the list of recognized control names (NUMXSR). The purpose of defining these additional controls is to allow the user to set such variables as landing gear position, wing sweep, or flap position. The controls are only defined in the additional surface specification records; actual control positions are defined in the analysis point definition records. If such controls are defined, the records defining them will have the format specified in table 1. The control variable name (ADDITIONAL SURFACE), location (LOCCNT) in the common block /CONTRL/, and the units associated with this control variable (CONVR) are specified for each additional control.

## Test Case Specification

The test case specification records allow the user to define the flight condition, or analysis point, at which a linear model is to be derived. Multiple cases can be included in the test case specification records. The final record in each set directs the program to proceed (NEXT) or to stop (END) execution.

The first record of a test case specification set determines the analysis point, or trim, option to be used for the current case. The ANALYSIS POINT DEFINITION OPTION parameter is read in and checked against the list of analysis point definition identifiers described in appendix E. The second record of a test case specification set, defining an analysis point definition suboption (ANALYSIS POINT DEFINITION SUBOPTION), will be read only if the requested analysis point definition option has a suboption associated with it. These suboptions are defined in the Analysis Point Definition section. The valid alphanumeric descriptors for these suboptions are described in appendix E.

The remaining records in a test case specification set define test conditions or initial conditions for the trimming subroutines. These records consist of a field defining a parameter name (VARIABLE) and its initial condition (VALUE). These records may be in any order; however, if initial Mach number is to be defined, the altitude must be specified before Mach number if the correct initial velocity is to be determined. The parameter names are checked against all name lists used within LINEAR. Any recognized state, time derivative of state, control, or observation variable will be accepted. Trim parameters also can be set in these records.

In general, setting observation variables and time derivatives of the state variables has little effect. However, for some of the trim options defined in the Analysis Point Definition section, Mach number and load factor are used. The thrust trim parameter only affects the specific power trim. For the untrimmed option, the initial values of the state and control variables determine the analysis point completely. For all other trim options, only certain states are not varied; all controls connected to the control and engine models are varied.

## Interactive Data Input

Upon starting program execution, LINEAR will ask the user:

WHAT IS THE TITLE OF THE CASE BEING RUN?

The user should answer with some meaningful title followed by a carriage return. This title, along with the vehicle title discussed later, will identify this interactive session on all of the output data files.

The program will then display the following menu:

PROGRAM LINEAR READS ALL INPUT DATA FROM 1  
UNLESS A DIFFERENT FILE NAME IS SPECIFIED.

- 1) ALL INPUT DATA IS ON 1
- 2) DATA IS ON ONE OTHER FILE

- 3) DATA IS ON VARIOUS FILES
- 4) INPUT DATA FROM A FILE(S) AND FROM THE TERMINAL
- 5) INPUT ALL DATA FROM THE TERMINAL

The user must answer with the appropriate number followed by a carriage return.

If the user answers with a "1", the program will read all the input data from the file assigned logical unit one. If the user selects choice "2", the program will ask for the file name that contains all the input data required by LINEAR. If the user selects "3" or "4", the program will prompt the user for each file name pertaining to each section of input data. If option "5" is chosen, the program will prompt the user for the input data values.

The data is separated into the six sections described previously:

1. Vehicle title information,
2. Vehicle geometry and mass properties,
3. State, control, and observation variable definitions,
4. Limits for the trim parameters,
5. Additional control surface definitions, and
6. Test case specifications.

The program will prompt the user for the name of the file that contains each section of data. An example prompt follows:

```
WHAT IS THE NAME OF THE FILE CONTAINING THE TITLE INFORMATION?  
(TYPE 0 TO INPUT THE TITLES FROM THE TERMINAL AND STORE ON A FILE)
```

If the user already has created a file containing the appropriate data needed for the section, a 10-character (maximum) file name may be entered. If the user wishes to type the data from the terminal and have the program format a file, a zero may be entered and the program will prompt

```
WHAT WOULD YOU LIKE THE FILE TO BE CALLED?
```

At this time the user must input a file name (10 characters maximum) on which all data typed from the terminal will be stored for that section of input data. LINEAR will then prompt the user for the specific data it needs for this section.

If the user wishes to input all the data from the terminal, selection "5" should be chosen and the program will prompt for a data file name on which to store the input data. The program will prompt the user for all the input data required.

When inputting the title data, the program reads character strings of 80 characters. When prompting for vehicle mass and geometry data, the program reads a floating point field. An example data prompt is as follows:

```
INPUT THE VEHICLE GEOMETRY AND MASS PROPERTIES
WING AREA (FT**2) =
```

The user would input the vehicle wing area in square feet followed by a carriage return. The remainder of the vehicle geometry data is input similarly.

When inputting the state vector from the terminal, the user must define the size and formulation of the state equation as well as the units in which the angle of attack and sideslip stability derivatives will be output. The program will prompt

```
HOW MANY STATE VARIABLES ARE IN YOUR MODEL?
(MAXIMUM 12)
```

The program will read an integer variable and then prompt

```
WHICH FORM OF THE STATE EQUATION DO YOU
WISH TO USE?
```

- 1)  $DX/DT = A*X + B*U + D*V$
- 2)  $C * DX/DT = A*X + B*U + D*V$

If the standard formulation is being used, the user should input "1" and for the generalized equation, "2". The LINEAR program uses the generalized formulation for internal calculations and then performs any transformations necessary for the output formulation requested. The program will then prompt for the units of the angle of attack and sideslip stability derivatives. The program uses radians for all internal calculations and transforms the stability derivatives to degrees for output if desired.

The variables used in the state vector are input next and are read in strings 20 characters in length. Each variable name entered is checked against legal names for state variables. If a variable is incorrect, the program will respond

```
VARIABLE so-and-so
IS AN INVALID STATE PARAMETER
PLEASE CHOOSE ANOTHER OR TYPE HELP FOR MORE INFO.
```

If the user types HELP, the program will list all the valid names for the state variables. The names are given in appendix D.

After the entire state vector has been entered, the program will prompt

```
THE STEP SIZE USED FOR DERIVATIVE EXTRACTION
IS INITIALIZED FOR ALL VARIABLES TO 0.001.
DO YOU WISH TO INPUT A DIFFERENT VALUE
FOR ANY OF THE STATE VARIABLES? (Y/N)
```

To change the perturbation step size for any of the state variables, the user should enter "Y" and, after being prompted, the variable name to be updated and the desired step size.

For the interactive input of the control variables, similar prompts are given with one major difference: after each variable name is input, the program prompts for the location of the variable in the common block /CONTRL/ (the named common block /CONTRL/ reserves 30 locations for control surface variable values used as interface to the user-supplied aerodynamic model). The program also prompts for the units to be used in calculations involving the control surface:

WHAT UNITS ARE USED IN CALCULATIONS WITH  
THIS CONTROL SURFACE?

- 1) NONE
- 2) DEGREES
- 3) RADIANS

The units should be consistent with the calculations in UCNTRL. The program performs transformations based on the surface type for the printer file only. No other control surface transformations are performed. Again, the derivative step size can be changed for individual variables specified by the user.

For the interactive input of the observation vector, similar prompts are given with a few variations. The forms available for the observation equation are

- 1)  $Y = H*X + F*U + E*V$
- 2)  $Y = H*X + G*DX/DT + F*U + E*V$

For variables defined in the observation vector as being offset from the vehicle center of gravity, the program will prompt for the offset in the x, y, and z stability axes. For any variables that are calculated based on some reference value, such as Reynolds number, the program prompts for the correct value when the name is entered. Again, the step size for derivative extraction can be modified for any observation variable. Valid observation variable names are listed in appendix C.

If selected to be input from the terminal, the program will prompt the user for the limits to be used for the trim parameters  $\delta_e$ ,  $\delta_a$ ,  $\delta_r$ ,  $\delta_{th}$ , which represent the longitudinal, lateral, directional, and thrust trim parameters, respectively. The units associated with these parameters are defined by the implementation of UCNTRL. (See app. J of this report for details.) An example prompt is as follows:

WHAT IS THE MAXIMUM THRUST PARAMETER?

Again, the program reads a floating point field.

After the trim axis parameter limits are defined, the program prompts

HOW MANY ADDITIONAL SURFACES DO YOU WISH  
TO DEFINE?

At this time, the user can define additional controls to be included in the list of recognized control names. The purpose of defining these additional surfaces is to allow the user to set such variables as landing gear position, wing sweep, or flap position. The control surface name, location in common /CONTRL/, and units are defined here for each surface; actual control surface positions are defined during analysis point definition.

The program will then prompt the user to indicate what aerodynamic model will be used for this analysis. Aerodynamic models are described in the next section of this report.

If a nonlinear aerodynamic model is used, the program will prompt the user to determine if there are additional control surfaces for which derivatives are desired. These controls will not become part of the control vector. This option of interactive LINEAR does not allow these control variables to be read from or saved to a file, and is not available on the batch version of LINEAR. However, the stability and control derivative output file will contain these surfaces and their derivatives.

The point at which the nonlinear system equations are linearized is referred to as the analysis or trim point. This can represent a true steady-state condition on the specific trajectory (a point at which the rotational and translational accelerations are zero) or a totally arbitrary state on a trajectory. LINEAR allows the user to select from a variety of analysis points. Within the program, these analysis points are referred to as trim conditions, and several options are available to the user.

If the user is defining the trim conditions interactively, instead of reading the data from a formatted file, the program will prompt:

WHAT TYPE OF TRIM DO YOU WISH TO RUN?

- 1) NO TRIM
- 2) STRAIGHT AND LEVEL FLIGHT
- 3) LEVEL TURN
- 4) PUSH-OVER/PULL-UP
- 5) THRUST STABILIZED TURN
- 6) BETA
- 7) SPECIFIC POWER

The user must specify the number corresponding to the type of trim desired. The arbitrary state and control option is designated as NO TRIM, and in selecting this option the user must specify all nonzero state and control variables.

For all of the analysis point definition options, any state or control parameter may be input after the required data is defined when the program prompts as follows:

WHAT OTHER STATE OR CONTROL VARIABLES WOULD  
YOU LIKE TO INITIALIZE?

TYPE HELP TO LIST VALID VARIABLES NAMES

(ENTER "N" IF NO OTHER CONDITION IS TO BE SPECIFIED)

The user should enter the name of the variable to be initialized or type HELP to list the variables that may be initialized.

If a level turn trim is selected, the user can specify the direction of the turn by entering "TURN RIGHT" or "TURN LEFT" when prompted to initialize any other variables. This is especially useful for asymmetric aircraft. Default is "TURN RIGHT".

If data are being read from a file(s), the data can be reviewed by replying "Y" when prompted

DO YOU WISH TO REVIEW THE DATA AS IT  
IS READ FROM THE INPUT FILE(S)? (Y/N)

If any data are entered incorrectly, the user should finish entering all data as prompted by the program until asked if there are any changes to be made:

DO YOU WISH TO CHANGE ANY PARAMETERS  
IN YOUR MODEL OR UPDATE THE INPUT  
CASE SELECTION FILE? (Y/N)

At this time, the user selects "Y" and the program prompts

WHAT PARAMETERS DO YOU WISH TO CHANGE?

- 1) VEHICLE GEOMETRY
- 2) STATE VECTOR
- 3) OBSERVATION VECTOR
- 4) CONTROL VECTOR
- 5) CASE INPUT FILE
- 6) STABILITY AND CONTROL DERIVATIVES
- 7) SURFACES TO BE SET
- 8) NO FURTHER CHANGES

Any section of data can be updated by reading a new data file or by typing in the data from the terminal. The program prompts the user to determine the source of input as explained previously. If the user wishes to modify the vehicle geometry and mass data or the stability and control derivatives interactively, the program saves all the values from the previous case and allows the user to modify any individual parameter. For example, if the user wishes to modify the vehicle geometry properties, a "1" would be entered and the program would continue

WHAT IS THE NAME OF THE FILE CONTAINING THE VEHICLE  
GEOMETRY AND MASS PROPERTIES?

(TYPE 0 TO INPUT THE DATA FROM THE  
TERMINAL AND STORE ON A FILE)

If the user replies with a zero, the program will prompt for a new output file name and then respond as follows:



GEOMETRY AND MASS DATA FOR:  
USER'S GUIDE

FOR THE PROJECT:  
DEMONSTRATION CASE

1)	WING AREA	608.000
2)	WING SPAN	42.800
3)	MEAN CHORD	15.950
4)	VEHICLE WEIGHT	40700.000
5)	IX	28700.000
6)	IY	165100.000
7)	IZ	187900.000
8)	IXZ	-520.000
9)	IXY	0.000
10)	IYZ	0.000

VECTOR DEFINING REFERENCE POINT OF AERODYNAMIC MODEL  
WITH RESPECT TO THE VEHICLE CENTER OF GRAVITY:

11)	DELTA X	0.000
12)	DELTA Y	0.000
13)	DELTA Z	0.000
14)	MINIMUM ANGLE OF ATTACK	-10.000
15)	MAXIMUM ANGLE OF ATTACK	40.000

16) FORCE AND MOMENT COEFFICIENTS CORRECTIONS DUE  
TO THE OFFSET OF THE REFERENCE POINT OF THE  
AERODYNAMIC MODEL FROM THE VEHICLE CG ARE  
INTERNALLY CALCULATED IN LINEAR. TYPE IN  
16=0 IF CALCULATIONS ARE DONE IN CCALC.

TO MAKE CHANGES, TYPE IN THE LINE NUMBER ON THE  
DESIRED VALUES.

"N" INDICATES NO CHANGES ARE DESIRED

"R" REFRESHES THE SCREEN WITH NEW VALUES.

FOR EXAMPLE: TO CHANGE VEHICLE WEIGHT

4=40000.0

If selection "16=0" is chosen, the program will set a logical variable that determines where center-of-gravity corrections are made to the force and moment coefficients. The vector defining the reference point of aerodynamic model with respect to the vehicle center of gravity must be defined in feet.

If the state, control, or observation vectors need to be modified, the user must input the entire vector again. The choices available for the test case selection are to input the data from the terminal for each case or read the entire case specification from a file.

All surfaces in the control model are initially zero unless specified in the case input file. Surfaces not in the control vector can be set by choosing option "7" when prompted for parameter changes. The program will prompt for the file name containing the surfaces that can be set for each case. If the user wishes to input the surface names interactively, the program will prompt for the number of surfaces to be added, their names, location in common /CONTRL/ and units used in subroutine UCNTL. If the location in common /CONTRL/ has already been designated for another surface, the program will save the original name and ignore any other name input for that location, and so inform the user.

The interactive LINEAR program provides the user with two different ways to calculate the total force and moment coefficients. One method is by using a full aerodynamic model and the subroutines ADATIN and CCALC. The other method uses a set of linearized stability and control derivatives, and the internal subroutine CLNCAL. When using the second method, the data can be typed in during execution or can be input from a file.

An example of a linearized stability and control data set is shown in appendix G. The first line contains the file description. The case number (1-999) at the end of the first line allows the user to correlate the linearized data from a case to other data from that case. The next line is the title of the run. The following two lines of text describe the project for which the case was run, and the next two lines list the reference altitude and Mach number for the case. The next line determines whether the alpha and beta derivatives are in units of degrees or radians. The following two lines indicate whether Mach or velocity derivatives will be read in. This is intended to warn the user against modifying the wrong derivative while editing outside of LINEAR. If the wrong derivative is changed, LINEAR will ignore the change. Additionally, if the reference altitude is changed, LINEAR will rely on the specified derivative and compute the other based on the speed of sound which is a function of altitude. While editing this file in LINEAR, this caution is not necessary since LINEAR will perform the computation right away. Also, when these derivatives are changed in LINEAR, the last velocity or Mach derivative changed will determine which one LINEAR will regard as the specified derivative when the file is output.

The next line determines the number of control surfaces used for control derivatives. The units of each of the control surfaces, where applicable, are listed next to the surface name as well as the location of the surface in the common /CONTRL/. The units defined for each surface correspond to the units defined in user-supplied subroutine CCALC.

The rest of the file contains the stability and control derivatives. This part is broken into six sections, one for each of the force and moment coefficients. In each section, there is one zero coefficient corresponding to zero angle of attack, zero sideslip, zero control surface deflection, and constant Mach and altitude. Each section also contains 10 stability derivatives. In addition, each section has as many control derivatives as specified earlier. The six sections must always be in the same order: rolling moment, pitching moment, yawing moment, drag force, lift force, and sideforce.

The easiest way to format a derivative file is by running the interactive LINEAR program and inputting the derivatives when prompted by the program. One of the out-

put files from LINEAR is the stability and control derivative file that can be used later to analyze the same case. (See the Aerodynamic Model section for more information.) When using a linearized set of stability and control derivatives from a previous case, the user must be careful to define a control vector that is consistent with the derivative set. If a surface is defined that does not have corresponding control derivatives on the file, that surface's effects on the forces and moments will not be included in the linear system model calculated. The user should also be aware that LINEAR expects to have control over all axes to determine a trimmed state. If there are no nonzero control derivatives in a given axis, it is highly likely that LINEAR will fail to trim; and it may even generate a fatal error in the nonlinear equation solver (generally a floating-point overflow).

#### AERODYNAMIC MODEL

As already stated, there are two methods for calculating the total force and moment coefficients. One method relies on a full nonlinear aerodynamic model to provide the stability and control derivatives. These derivatives are stored in common blocks in the user-supplied routine ADATIN and used in CCALC to calculate the total force and moment coefficients using the state and control surface values calculated in LINEAR. These subroutines and the aerodynamic model are the same ones used in the manned simulations at Ames-Dryden.

Using a full aerodynamic model with CCALC and ADATIN enables the user to run as many cases as desired without changing derivative data sets. From each case, the program generates a structured linearized derivative data file which can be used as an input file later. This file contains all the stability and control derivatives for the control surfaces specified in the control vector, and any other controls specified by the user. The interface required for using a nonlinear aerodynamic model is described later in the Aerodynamic Model Subroutines section.

The other method for calculating total force and moment coefficients requires the user to supply linearized stability and control derivatives. These are used in the internal subroutine CLNCAL to calculate the total force and moment coefficients. When using this option, care must be taken to ensure that the input data is valid for the trim point desired. Center-of-gravity shifts will not affect the data that is output to the derivative file when this method is used.

The method used to calculate the force and moment coefficients is specified during the input phase for a particular case. After all the vehicle data, state, control, observation vectors, and case data have been defined, the program will prompt

DO YOU WISH TO

- 1) INPUT A SET OF LINEAR STABILITY  
AND CONTROL DERIVATIVES
- 2) OR USE THE NONLINEAR MODEL  
YOU HAVE INTERFACED WITH THIS PROGRAM

If the internal routines are to be used to calculate the derivatives, the program will prompt

DO YOU WISH TO

- 1) GENERATE A NEW DATA SET
- 2) OR USE A DERIVATIVE DATA SET YOU HAVE ON FILE
- 3) OR MODIFY THE OLD ONE

If the derivatives are stored on a file (format for the file is given in app. G), the program will prompt for a file name. At this point, the user can modify the data interactively by choosing one of the following options:

TO CHANGE ANY DERIVATIVES, INPUT THE  
APPROPRIATE LINE # TO SEE THE DATA.  
TYPE IN "N" IF NO CHANGES DESIRED

- 1) TYPE OF ANGLE MEASUREMENT
- 2) ROLL MOMENT
- 3) PITCH MOMENT
- 4) YAW MOMENT
- 5) DRAG FORCE
- 6) LIFT FORCE
- 7) SIDE FORCE
- 8) ADD SURFACES

If the user selects option one, the program will list the units that are used for output of the stability derivatives. It will also list the units for each control surface derivative as used for calculations in the subroutine UCNTRL. There are three choices for units for the control surfaces: none, radians, and degrees. If the control surface calculations in UCNTRL are nondimensional, the user should specify none, and no conversion is done. For surface calculations in radians, a conversion to degrees for output only is performed. If degrees is specified, no conversion is done. When the user inputs the stability and control derivatives, the program does not perform any conversions, therefore, care must be taken to ensure that the units are consistent with the aerodynamic model and the calculations in UCNTRL.

If option "8" is chosen, the control surfaces defined are listed, and the user can define other surfaces in common /CONTRL/ for which derivatives exist.

If the derivatives are to be calculated from a nonlinear aerodynamic model, the program will prompt for the names of any other control surfaces not defined in the control vector for which linearized derivatives will be calculated. If options "2" through "7" are chosen, the program will list the current values for the stability and control derivatives for each respective coefficient. The user can change these values interactively, as in the following example:

ROLL MOMENT DERIVATIVES

WITH RESPECT TO:

0) CLO	-0.000033820
1) ROLL RATE (RAD/SEC)	-0.200000003
2) PITCH RATE (RAD/SEC)	0.000000000
3) YAW RATE (RAD/SEC)	0.163589999

4)	VELOCITY	(FT/SEC)	-0.000000115
5)	MACH NUMBER		-0.000119522
6)	ALPHA	(DEG/SEC)	0.000362335
7)	BETA	(DEG/SEC)	-0.140983000

. :  
: :  
. :

TO MAKE CHANGES, TYPE IN THE LINE NUMBER  
AND THE VALUE OF THE DERIVATIVE.

"N" INDICATES NO CHANGES ARE DESIRED  
"R" REFRESHES THE SCREEN WITH THE NEW VALUES  
FOR EXAMPLE: ROLL MOMENT WRT ALPHA

6=0.003

#### OUTPUT FILES

There are four output files from LINEAR: (1) a general-purpose analysis file, (2) a printer file containing the calculated case conditions and the state-space matrices for each case, (3) a printer file containing the calculated case conditions only, and (4) a linearized set of stability and control derivatives. LINEAR also outputs any data input by the user during an interactive session that can be used later either by the batch or interactive programs. The program prompts the user for the file names that each of the sections of data will be written to, as described in the Interactive Data Input section.

The general-purpose analysis file contains the following: the title of the case being analyzed; the state, control, and observation variables used to define the state-space model; and the state and observation matrices calculated in LINEAR. The C and G matrices are printed only if the user has selected an appropriate formulation of the state and observation equations. The output for this file is assigned to FORTRAN device number 15. An example general-purpose analysis file is presented in appendix H corresponding to the format of table 2.

The vehicle and case titles are written on the first two records of the analysis file in 80-character strings and are specified in LINEAR as the title of the vehicle and the title of the cases. The next record contains the number of the case as defined in LINEAR (maximum of 999 cases).

The number of states, controls, and outputs used to define each case is written on the subsequent record. The formulation of the state and observation equations is listed next, followed by the names and values of the states, controls, dynamic interaction variables, and outputs. These values are followed by the matrices that describe each case.

The title records only appear at the beginning of the file while all other records are duplicated for each subsequent case calculated in LINEAR. The matrices are written row-wise, five columns at a time as shown in table 3. This table shows a system containing seven states, three controls, and eleven outputs using the general state equation and standard observation equation.

TABLE 2. - ANALYSIS FILE FORMAT

Variable	Format
Title of the case	(4A20)
Title of the aircraft	(4A20)
Case number	(//,64X,I3)
Number of states, controls, and outputs	(17X,I2,22X,I2,22X,I3)
State equation formulation	(36X,2A4)
Observation equation formulation	(36X,2A4)
	(////)
State variable names, values and units	(1X,5A4,3X,E12.6,2X,A20)
	(////)
Control variable names, values and units	(1X,5A4,3X,E12.6,2X,A20)
	(////)
Dynamic interaction variable names and units	(1X,5A4,17X,A20)
	(////)
Output variable names, values and units	(1X,5A4,3X,E12.6,2X,A20)
Matrix name	(//,A8,/) )
A-Matrix	(5(E13.6))
Matrix name	(//,A8,/) )
B-Matrix	(5(E13.6))
Matrix name	(//,A8,/) )
D-Matrix	(5(E13.6))
Matrix name	(//,A8,/) )
C-Matrix (if general form chosen)	(5(E13.6))
Matrix name	(//,A8,/) )
H-Matrix	(5(E13.6))
Matrix name	(//,A8,/) )
F-Matrix	(5(E13.6))
Matrix name	(//,A8,/) )
E-Matrix	(5(E13.6))
Matrix name	(//,A8,/) )
G-Matrix (if general form chosen)	(5(E13.6))

TABLE 3. - ANALYSIS FILE OUTPUT  
MATRIX STRUCTURE

Size of matrix	Output formulation
A = [ 7 x 7]	A = [ 7 x 5] [ 7 x 2]
B = [ 7 x 3]	B = [ 7 x 3]
D = [ 7 x 6]	D = [ 7 x 5] [ 7 x 1]
C = [ 7 x 7]	C = [ 7 x 5] [ 7 x 2]
H = [11 x 7]	H = [11 x 5] [11 x 2]
F = [11 x 3]	F = [11 x 3]
E = [11 x 6]	E = [11 x 5] [11 x 1]

The second output file, which is assigned to FORTRAN device unit number 3, contains the values calculated in LINEAR describing each case. The first section of this file contains a listing of the input data defining the aircraft's geometry and mass properties, variable names defining the state-space model, and various control surface limits characteristic of the given aircraft. Appendix I presents an example printer output file.

The second section of this file contains the trim conditions of the aircraft at the point of interest. These conditions include the type of trim being attempted, whether trim was achieved, and parameters defining the trim condition.

The values for the variables of the state-space model at the trim condition are also printed. If trim was not achieved,  $\dot{p}$ ,  $\dot{q}$ ,  $\dot{r}$ ,  $\dot{V}$ ,  $\dot{\beta}$ , and  $\dot{\alpha}$  (calculated from the equations of motion) and the force and moment coefficients are printed. Changes in the geometry and mass properties are also printed.

The third section of this output file contains the nondimensional stability and control derivatives for the trim condition calculated. The static margin of the aircraft at the given flight condition is also printed.

The final section of this output file contains the state and observation matrices for the given flight condition. The formulation of the state equations and only the terms of the matrices chosen by the user to define the model are printed.

The third output file, which is assigned to FORTRAN device unit 2, contains the trim conditions of the aircraft at the point of interest. These conditions include the type of trim being attempted, whether trim was achieved, parameters defining the trim condition, and the static margin of the aircraft at the given flight condition. Appendix I also presents an example of this file.

The fourth output file is the set of linearized stability and control derivatives for each case as defined in the Aerodynamic Model section.

#### USER-SUPPLIED SUBROUTINES

There are five subroutines that must be supplied by the user to interface LINEAR with a specific aircraft's subsystem models: ADATIN, CCALC, IFENGN, UNCTRL, and MASGEO. The first two subroutines comprise the aerodynamic model. The subroutine IFENGN is used to provide an interface between LINEAR and any engine modeling routines the user may wish to incorporate. UNCTRL converts the trim parameters used by LINEAR into control surface deflections for the aerodynamic modeling routines. MASGEO enables the mass and geometry properties to change as the aircraft configuration does (for example, with wing sweep). The use of these subroutines is illustrated in figure 3 which shows the program flow and the interaction of LINEAR with the user-supplied subroutines. These subroutines are described in detail on the following pages. Examples of these subroutines can be found in appendix J.



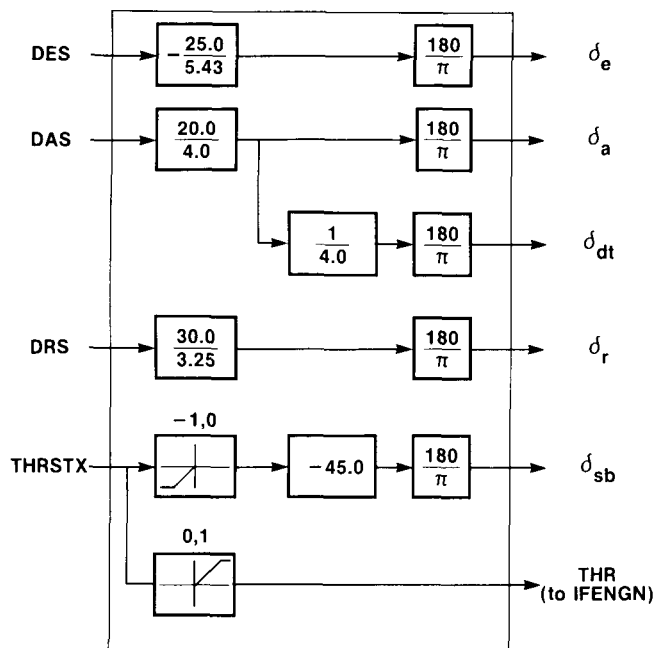

Figure 3. Program flow diagram showing communication with user-supplied subroutines.

#### Aerodynamic Model Subroutines

It is assumed that the aerodynamic models consist of two main subroutines: ADATIN and CCALC. ADATIN is used to input the basic aerodynamic data from remote storage. ADATIN can also be used to define aerodynamic data. CCALC is the subroutine that uses this aerodynamic data, the state variables, and the surface positions to determine the aerodynamic coefficients. Either routine may call other subroutines to perform related or required functions; however, from the point of view of the interface to LINEAR, only these two subroutines are required for an aerodynamic model.

Externally, ADATIN has no interface to the program LINEAR. The subroutine is called only once when the aerodynamic data is input or defined. The calling program has to provide ADATIN with the input devices it requires, but no other accommodation is necessary. The aerodynamic data is communicated from ADATIN to CCALC through named common blocks that occur only in these two routines.

The interface between CCALC and the calling program is somewhat more complicated. However, the interface is standard and this feature provides a framework about which a general purpose tool can be built. This interface consists of several named common blocks which are used to pass state variables, air data parameters, surface positions, and force and moment coefficients between CCALC and the calling program. CCALC is executed whenever new aerodynamic coefficients are required (for example, once per frame for a real-time simulation).

The main transfer of data into the subroutine CCALC is through five named common blocks. These common blocks contain the state variables, air data parameters, and

Externally, ADATIN has no interface to the program LINEAR. The subroutine is called only once when the aerodynamic data is input or defined. The calling program has to provide ADATIN with the input devices it requires, but no other accommodation is necessary. The aerodynamic data is communicated from ADATIN to CCALC through named common blocks that occur only in these two routines.

The interface between CCALC and the calling program is somewhat more complicated. However, the interface is standard and this feature provides a framework about which a general purpose tool can be built. This interface consists of several named common blocks which are used to pass state variables, air data parameters, surface positions, and force and moment coefficients between CCALC and the calling program. CCALC is executed whenever new aerodynamic coefficients are required (for example, once per frame for a real-time simulation).

The main transfer of data into the subroutine CCALC is through five named common blocks. These common blocks contain the state variables, air data parameters, and surface positions. The transfer of data from CCALC is through a named common block containing the aerodynamic force and moment coefficients. The details of these common blocks follow.

The common block /DRVOUT/ contains the state variables and their derivatives with respect to time. The structure of this common block is given as follows:

```
COMMON /DRVOUT/ T      ,
                   P    , Q    , R    ,
                   V    , ALP  , BTA  ,
                   THA  , PSI  , PHI  ,
                   H    , X    , Y    ,
                   TDOT ,
                   PDOT , QDOT  , RDOT ,
                   VDOT , ALPDOT, BTADOT,
                   THADOT, PSIDOT, PHIDOT,
                   HDOT  , XDOT  , YDOT
```

The body axis rates  $p$ ,  $q$ , and  $r$  appear as  $P$ ,  $Q$ , and  $R$ , respectively. Total velocity is represented by the variable  $V$  and the altitude by  $H$ . Angle of attack ( $ALP$ ), angle of sideslip ( $BTA$ ), and their derivatives with respect to time ( $ALPDOT$  and  $BTADOT$ , respectively) are also contained within this common block.

The common block /SIMOUT/ contains the main air-data parameters required for the aerodynamic model. The variables in this common block are as follows:

```
COMMON /SIMOUT/ AMCH, QBAR, GMA, DEL,
                   UB  , VB  , WB  ,
                   VEAS, VCAS
```

Mach number and dynamic pressure are the first two entries in the common block symbolized by  $AMCH$  and  $QBAR$ , respectively. The body axis velocities  $u$ ,  $v$ , and  $w$  are included as  $UB$ ,  $VB$ , and  $WB$ , respectively.

The /CONTRL/ common block contains the surface position information. The exact definition of each of the elements used for a particular aerodynamic model is determined by the implementer of that model. The structure of the common block /CONTRL/ is as follows:

```
COMMON /CONTRL/ DC (30)
```

The common block /DATAIN/ contains geometry and mass information. The first three variables in the common block, S, B, and CBAR, represent wing area, wing span and mean aerodynamic chord, respectively. The vehicle mass is represented by AMSS. The structure of common /DATAIN/ is as follows:

```
COMMON /DATAIN/ S , B , CBAR, AMSS,  
AIX , AIY , AIZ , AIXZ,  
AIXY, AIYZ, AIXE
```

The information on the displacement of the reference point of the aerodynamic data with respect to the aircraft center of gravity is contained in the /CGSHFT/ common block:

```
COMMON /CGSHFT/ DELX, DELY, DELZ
```

The displacements are defined along the vehicle body axis with DELX, DELY, and DELZ representing the displacements for the x, y, and z axes, respectively.

The output common block /CLCOUT/ contains the variables representing the aerodynamic moment and force coefficients:

```
COMMON /CLCOUT/ CL, CM, CN, CD, CLFT, CY
```

The variables CL, CM, and CN are the symbols for the rolling moment ( $C_l$ ), pitching moment ( $C_m$ ), and yawing moment ( $C_n$ ) coefficients, respectively; these terms are body axis coefficients. The stability axis forces are represented by CD, coefficient of drag ( $C_D$ ); CLFT, coefficient of lift ( $C_L$ ); and CY, sideforce coefficient ( $C_Y$ ).

#### Control Model Subroutines

The LINEAR program attempts to trim the given condition using control inputs similar to that of a pilot: longitudinal stick, lateral stick, rudder, and throttle. The UCNTRL subroutine uses these trim output control values to calculate actual surface deflections and power lever angles for the given aircraft (fig. 2). The location of each surface and power lever angle in the /CONTRL/ common block is specified by the user in the input file (maximum of 30 surfaces). The limits for the control parameters in pitch, roll, yaw, and thrust are user specified and must agree in units with the calculations in CCALC.

The common block /CTPARAM/ contains the four trim parameters that must be related to surface deflections in the subroutine UCNTRL:

```
COMMON /CTPARAM/ DES, DAS, DRS, THRSTX
```

The output from UCNTL is via the common block /CONTRL/ described previously in the Aerodynamic Model Subroutines section. The variables DES, DAS, DRS, and THRSTX are used to trim the longitudinal, lateral, directional, and thrust axes, respectively.

For an aircraft using feedback (such as a statically unstable vehicle), state variables and their derivatives are available in the common block /DRVOUT/. However, this control model must contain no states of its own. If parameters other than state variables and their time derivatives are required for feedback, the user may access them using the common block /OBSERV/ described later in the Mass and Geometry Model Subroutines section of this report.

### Engine Model Subroutines

The subroutine IFENGN computes individual engine parameters used by LINEAR to calculate force, torque, and gyroscopic effects due to engine offset from the centerline. The parameters for each engine (maximum of four engines) are passed through common /ENGSTF/ as follows:

```
COMMON /ENGSTF/ THRUST(4), TLOCAT(4,3), XYANGL(4), XZANGL(4),  
                TVANXY(4), TVANXZ (4), DXTHRS(4),  
                EIX (4), AMSENG (4), ENGOMG(4)
```

The variables in this common block correspond to thrust (THRUST); x, y, and z body axis coordinates of the point at which thrust acts (TLOCAT); the orientation of the thrust vector in the x-y body axis plane (XYANGL), in degrees; the orientation of the thrust vector in the x-z body axis plane (XZANGL), in degrees; the orientation of the thrust vector in the x-y engine axis plane (TVANXY), in degrees; and the orientation of the thrust vector in the x-z engine axis plane (TVANXZ), in degrees. The distance between the center of gravity of the engine and the thrust point (DXTHRS), measured positive in the negative x engine axis direction; the rotational inertia of the engine (EIX); mass (AMSENG); and the rotational velocity of the engine (ENGOMG) are also in this common block. The variables are all dimensioned to accommodate up to four engines. Appendix B provides graphical and physical descriptions of these parameters.

While the common block structure within LINEAR is designed for engines that do not interact with the vehicle aerodynamics, propeller-driven aircraft can be easily modeled by communicating the appropriate parameters from the engine model IFENGN to the aerodynamic model CCALC.

### Mass and Geometry Model Subroutines

The subroutine MASGEO allows the user to vary the center-of-gravity position and vehicle inertias automatically. Nominally, this subroutine must exist as one of the user subroutines, but it may be nothing more than a RETURN and END statement. MASGEO is primarily for variable-geometry aircraft (such as an oblique-wing or variable-sweep configuration) or for modeling aircraft that undergo significant mass or inertia changes over their operating range. The center-of-gravity position and inertias may be functions of flight condition or any surface defined in the /CONTRL/ common

block. Changes in center-of-gravity position are passed in the /CGSHFT/ common block, and inertia changes are passed in the /DATAIN/ common block.

Care must be taken when using the subroutine MASGEO in combination with selecting an observation vector that contains measurements away from the center of gravity. If measurements are desired at a fixed location on the vehicle, such as a sensor platform or nose boom, the moment arm to the new center-of-gravity location must be recomputed as a result of the center-of-gravity shift for accurate results. This can be accomplished by implementing the moment arm calculations in one of the user subroutines and passing the new moment arm values through the /OBSERV/ common block.

COMMON /OBSERV/ OBVEC (120), PARAM (120,6)

The common block /OBSERV/ allows the user to access all the observation variables during trim as well as to pass parameters associated with the observations back to LINEAR. The common block /OBSERV/ contains two single-precision vectors: OBVEC(120), and PARAM(120,6). A list of the available observations and parameters is given in appendix C. Access to the observation variables allows the users to implement trim strategies that are functions of observations, such as gain schedules and surface management schemes. The parameters associated with the observations are used primarily to define the moment arm from the center of gravity to the point at which the observation is to be made. If the user subroutine MASGEO is used to change the center-of-gravity location and observations are desired at fixed locations on the vehicle, then the moment arm from the new center-of-gravity location to the fixed sensor location ((x, y, z), in feet) must be computed in one of the user subroutines and passed back in the first three elements of the PARAM vector associated with the desired observation (PARAM(n = 1 to 3), where n is the number of the desired observation). Additional information on observations and parameters can be found in the State, Control, and Observation Variable Definitions section.

#### CONCLUDING REMARKS

The FORTRAN program LINEAR was developed to provide a flexible, powerful, and documented tool to derive linear models for aircraft stability analysis and control law design. This report discusses the interactive LINEAR program, describing the interfaces to user-supplied subroutines and input files. The output from LINEAR is also described. Examples of the user-supplied subroutines are presented in appendix J. A microfiche listing of the program for a VAX 11/750 (Digital Equipment Corporation, Maynard, Massachusetts) with the VMS operating system is included with this report. The program is written in standard FORTRAN 77 so that it may be ported to other computers without modification.

The program LINEAR numerically determines a linear system model using nonlinear equations of motion and a user-supplied nonlinear aerodynamic model. LINEAR is also capable of extracting linearized engine effects, such as net thrust, torque, and gyroscopic effects and including these effects in the linear system model. The point at which this linear system model is defined is determined either by completely specifying the state and control variables or by specifying an analysis point on a trajectory, selecting a trim option, and directing the program to determine the control variables and remaining state variables.

LINEAR has several features that make it unique among the linearization programs common in the aerospace industry. The most significant of these features is flexibility. By generalizing the surface definitions and making no assumptions of symmetric mass distributions, the program can be applied to any aircraft in any phase of flight except hover. The unique trimming capability, provided by means of a user-supplied subroutine, allows unlimited possibilities of trimming strategies and surface scheduling, which are particularly important for asymmetrical vehicles and aircraft having multiple surfaces affecting a single axis. The formulation of the equations of motion permit the inclusion of thrust-vectoring effects. The ability to select, without program modification, the state, control, and observation variables for the linear models, combined with the large number of observation quantities available, allows any analysis problem to be attacked with ease.

This report documents the use of the program LINEAR, defining the equations and the methods used to implement the program. The trimming capabilities of LINEAR are discussed from both theoretical and implementation perspectives. The input and output files are described in detail. The user-supplied subroutines required for LINEAR are discussed and sample subroutines are presented.

*Ames Research Center  
Dryden Flight Research Facility  
National Aeronautics and Space Administration  
Edwards, California, November 3, 1987*

APPENDIX A: CORRECTION TO AERODYNAMIC COEFFICIENTS FOR A CENTER OF GRAVITY NOT AT THE AERODYNAMIC REFERENCE POINT

The point on the vehicle at which the nonlinear force and moment coefficients are defined is referred to as the aerodynamic reference point. All aerodynamic effects are modeled at this aerodynamic reference point. Thus, when this point and the vehicle center of gravity are not coincident, the forces acting at the aerodynamic reference point effectively induce moments that act incrementally on the moments defined at the aerodynamic reference point by the nonlinear aerodynamic model.

The total aerodynamic moment  $M$  acting at the vehicle center of gravity is defined as

$$M = M_{ar} + \Delta r \times F$$

where

$$M_{ar} = [L_{ar} \quad M_{ar} \quad N_{ar}]^T$$

is the total aerodynamic moment acting at the aerodynamic reference point (denoted by subscript ar) of the vehicle,

$$\Delta r = [\Delta x \quad \Delta y \quad \Delta z]^T$$

is the displacement of the aerodynamic reference point from the vehicle center of gravity, and

$$F = [X \quad Y \quad Z]^T$$

is the total aerodynamic force acting at the aerodynamic center where  $x$ ,  $y$ , and  $z$  are total forces along the  $x$ ,  $y$ , and  $z$  body axes. Thus,

$$M = \begin{bmatrix} L_{ar} + \Delta y Z - \Delta z Y \\ M_{ar} + \Delta z X - \Delta x Z \\ N_{ar} + \Delta x Y - \Delta y X \end{bmatrix}$$

The total aerodynamic moment acting at the vehicle center can be expressed in terms of the force and moment coefficients derived from the user-supplied nonlinear aerodynamic modeling subroutine CCALC by defining the body axis forces in terms of stability axis force coefficients:

$$X = \bar{q}S(-C_D \cos \alpha + C_L \sin \alpha)$$

$$Y = \bar{q}SC_Y$$

$$Z = \bar{q}S(-C_D \sin \alpha - C_L \cos \alpha)$$

Equations obtained by substituting these equations into the definition of the total aerodynamic moment equation and applying the definitions of the total aerodynamic moments, result in

$$L_{ar} = \bar{q}SbC_{\ell_{ar}}$$

$$M_{ar} = \bar{q}ScC_{m_{ar}}$$

$$N_{ar} = \bar{q}SbC_{n_{ar}}$$

Expressions for total aerodynamic moment coefficients corrected to the vehicle center of gravity can be derived as follows:

$$C_{\ell} = C_{\ell_{ar}} + \frac{\Delta y}{b} (-C_D \sin \alpha - C_L \cos \alpha) - \frac{\Delta z}{b} C_Y$$

$$C_m = C_{m_{ar}} + \frac{\Delta z}{c} (-C_D \cos \alpha + C_L \sin \alpha) - \frac{\Delta x}{c} (-C_D \sin \alpha - C_L \cos \alpha)$$

$$C_n = C_{n_{ar}} + \frac{\Delta x}{b} C_Y - \frac{\Delta y}{b} (-C_D \cos \alpha + C_L \sin \alpha)$$

These calculations are normally performed within LINEAR in the subroutine CGCALC. However, if the user elects, the calculation can be performed within the user-supplied aerodynamic model CCALC.



## APPENDIX B: ENGINE TORQUE AND GYROSCOPIC EFFECTS MODEL

Torque and gyroscopic effects represent (after thrust) the main contributions of the engines to the aircraft dynamics. The torque effects arise due to thrust vectors not acting at the vehicle center of gravity. The gyroscopic effects are a consequence of the interaction of the rotating mass of the engine and the vehicle dynamics. These effects can be either major or virtually negligible, depending on the vehicle.

The torque effects can be modeled by considering the thrust of an engine  $F_p$ , where the thrust vector is aligned with the local x axis of the engine acting at some point  $\Delta r$  from the center of gravity of the vehicle (fig. 4).

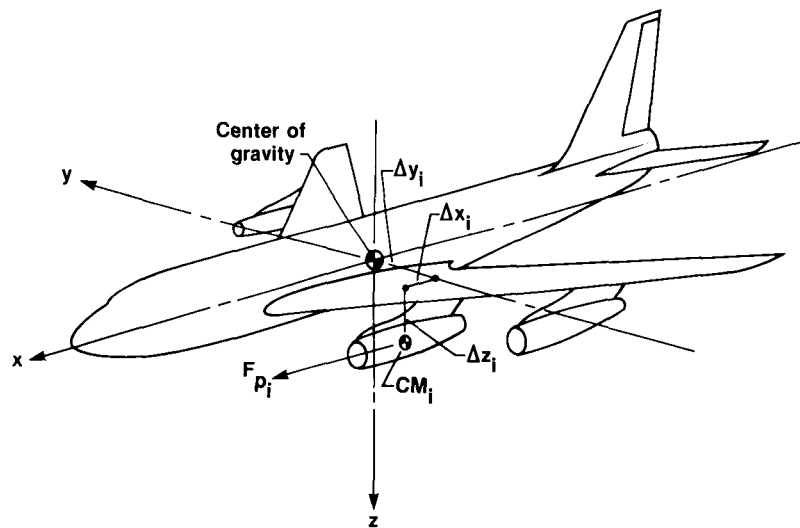

**Figure 4. Definition of location of engine center of mass ( $cm_i$ ) relative to vehicle center of gravity.**

The thrust vector for the  $i$ th engine  $F_{p_i}$  can be defined as

$$F_{p_i} = [F_{p_{x_i}} \quad F_{p_{y_i}} \quad F_{p_{z_i}}]^T$$

where  $F_{p_{x_i}}$ ,  $F_{p_{y_i}}$ , and  $F_{p_{z_i}}$  are the components of thrust in the  $x$ ,  $y$ , and  $z$  body axes, respectively. From figures 5 and 6 it can be seen that the following relationships hold:

$$F_{p_{x_i}} = |F_{p_i}| \cos \epsilon_i \cos \xi_i$$

$$F_{p_{y_i}} = |F_{p_i}| \cos \epsilon_i \sin \xi_i$$

$$F_{p_{z_i}} = -|F_{p_i}| \sin \epsilon_i$$

where  $|F_{p_i}|$  represents the magnitude of the thrust due to the  $i$ th engine,  $\epsilon_i$  the angle from the thrust axis of the engine to a plane parallel to the  $x$ - $y$  body axis plane, and  $\xi_i$  the angle from the projection of  $F_{p_i}$  onto the plane parallel to the  $x$ - $y$  body axis plane to the  $x$  body axis.

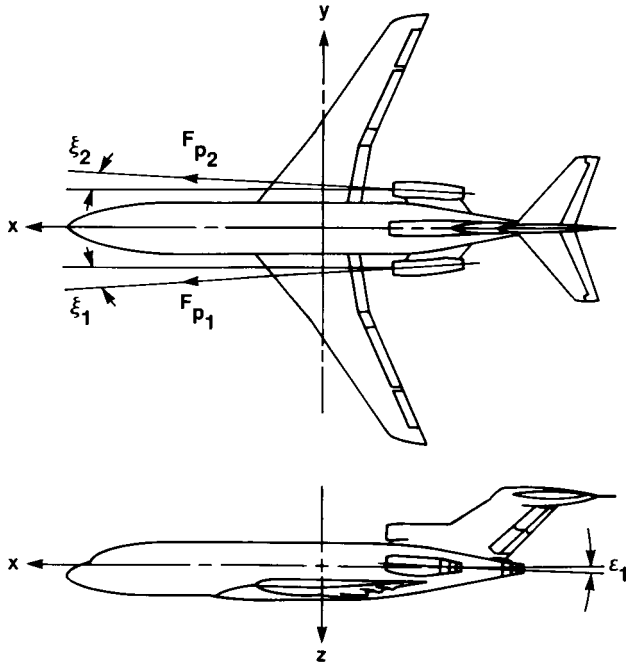

Figure 5. Orientation of the engines in the  $x$ - $y$  and  $x$ - $z$  body planes.

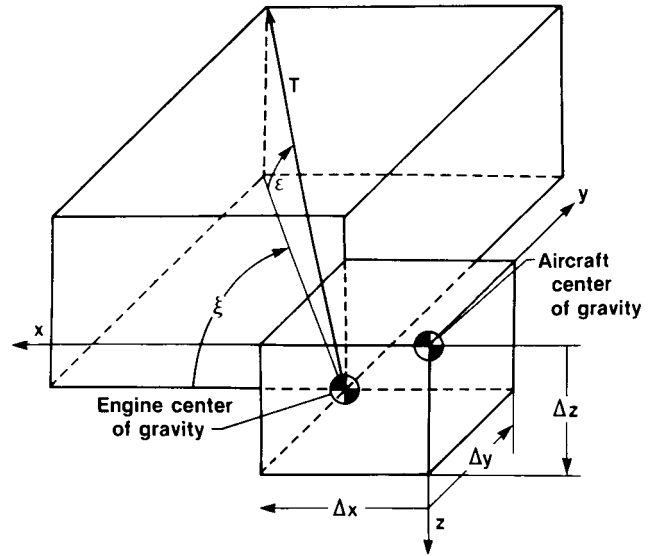

Figure 6. Detailed definition of engine location and orientation parameters.

Denoting the point at which the thrust from the  $i$ th engine acts as  $\Delta r_i$ , this offset vector can be defined as

$$\Delta r_i = [\Delta x_i \quad \Delta y_i \quad \Delta z_i]^T$$

where  $\Delta x_i$ ,  $\Delta y_i$ , and  $\Delta z_i$  are the  $x$ ,  $y$ , and  $z$  body axis coordinates, respectively, of the origin of the  $i$ th thrust vector.

The torque due to offset from the center of gravity of the  $i$ th engine  $\Delta \tau_{O_i}$  is then given by

$$\Delta \tau_{O_i} = \Delta r_i \times F_{p_i}$$

Thus,

$$\Delta \tau_{O_i} = \begin{bmatrix} \Delta y F_{p_{z_i}} - \Delta z F_{p_{y_i}} \\ \Delta z F_{p_{x_i}} - \Delta x F_{p_{z_i}} \\ \Delta x F_{p_{y_i}} - \Delta y F_{p_{x_i}} \end{bmatrix}$$

The total torque due to engines offset from the center of gravity of the vehicle  $\tau_0$  is given by

$$\tau_0 = \sum_{i=1}^n \Delta\tau_{0i} = \sum_{i=1}^n (\Delta\mathbf{r}_i \times \Delta\mathbf{F}_{P_i})$$

where  $n$  is the number of engines.

For the case of vectored thrust, the equations for torque produced at the vehicle center of gravity from the  $i$ th engine  $\Delta\tau_{0i}$  are somewhat more complicated. Figure 7 schematically represents an engine with thrust vectoring whose center of gravity is located at  $\Delta\mathbf{r}_i$  relative to the vehicle's center of gravity.

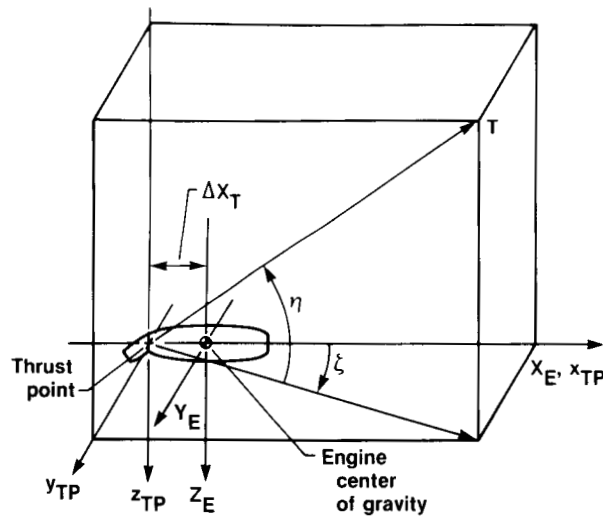

Figure 7. Detailed definition of thrust-vectoring parameters.

The thrust is assumed to act at  $-\Delta x_T$  in the local (engine)  $x$  axis, with the engine center of gravity being the origin of this local coordinate system. The thrust is also assumed to be vectored at angles  $\eta_i$  and  $\zeta_i$  relative to the local coordinate axes, with  $\eta_i$  being the angle from the thrust vector to the engine  $x$ - $y$  plane and  $\zeta_i$  the angle from the projection of the thrust vector onto the engine  $x$ - $y$  plane to the local  $x$  axis. Thus, letting  $F'_{P_{x_i}}$ ,  $F'_{P_{y_i}}$ , and  $F'_{P_{z_i}}$  represent the  $x$ ,  $y$ , and  $z$  thrust components in the local engine coordinate system, respectively, these terms can be defined in terms of the total thrust for the  $i$ th engine  $F_{P_i}$  and the angles  $\eta_i$  and  $\zeta_i$  as

$$F'_{P_{x_i}} = |F_{P_i}| \cos \eta_i \cos \zeta_i$$

$$F'_{P_{y_i}} = |F_{P_i}| \cos \eta_i \sin \zeta_i$$

$$F'_{P_{z_i}} = -|F_{P_i}| \sin \eta_i$$

where

$$\mathbf{F}_{P_i} = [F'_{Px_i} \quad F'_{Py_i} \quad F'_{Pz_i}]^T$$

To transform this equation from the  $i$ th engine axis system to the body axis system, the transformation matrix

$$\begin{bmatrix} \cos \epsilon_i \cos \xi_i & -\sin \xi_i & \sin \epsilon_i \cos \xi_i \\ \cos \epsilon_i \sin \xi_i & \cos \xi_i & \sin \epsilon_i \sin \xi_i \\ -\sin \epsilon_i & 0 & \cos \epsilon_i \end{bmatrix}$$

is used.

The resultant force in body axis coordinates is

$$\mathbf{F}_{P_i} = \begin{bmatrix} F_{Px_i} \\ F_{Py_i} \\ F_{Pz_i} \end{bmatrix} = \begin{bmatrix} \cos \epsilon_i \cos \xi_i & -\sin \xi_i & \sin \epsilon_i \cos \xi_i \\ \cos \epsilon_i \sin \xi_i & \cos \xi_i & \sin \epsilon_i \sin \xi_i \\ -\sin \epsilon_i & 0 & \cos \epsilon_i \end{bmatrix} \begin{bmatrix} F'_{Px_i} \\ F'_{Py_i} \\ F'_{Pz_i} \end{bmatrix}$$

so that

$$F_{Px_i} = |\mathbf{F}_{P_i}| (\cos \eta_i \cos \zeta_i \cos \epsilon_i \cos \xi_i - \cos \eta_i \sin \zeta_i \sin \xi_i - \sin \eta_i \sin \epsilon_i \cos \xi_i)$$

$$F_{Py_i} = |\mathbf{F}_{P_i}| (\cos \eta_i \cos \zeta_i \cos \epsilon_i \sin \xi_i + \cos \eta_i \sin \zeta_i \cos \xi_i - \sin \eta_i \sin \epsilon_i \sin \xi_i)$$

$$F_{Pz_i} = |\mathbf{F}_{P_i}| (-\cos \eta_i \cos \zeta_i \sin \epsilon_i - \sin \eta_i \cos \epsilon_i)$$

The moment arm through which the vectored thrust acts is

$$\Delta \mathbf{r}'_i = \begin{bmatrix} \Delta x_i - \Delta x_{T_i} \cos \epsilon_i \cos \xi_i \\ \Delta y_i - \Delta x_{T_i} \cos \epsilon_i \sin \xi_i \\ \Delta z_i + \Delta x_{T_i} \sin \epsilon_i \end{bmatrix}$$

and the total torque due to thrust vectoring is

$$\tau_o = \sum_{i=1}^n \Delta \tau_{O_i} = \sum_{i=1}^n (\Delta \mathbf{r}'_i \times \Delta \mathbf{F}_{P_i})$$

The gyroscopic effects due to the interaction of the rotating mass of the engines and the vehicle dynamics can be derived from the equation for the rate of change of angular momentum,

$$\tau_{g_i} = \dot{h}_{e_i} + \omega \times (I_{e_i} \omega_{e_i})$$

where  $\tau_{g_i}$  is the gyroscopic moment produced by the  $i$ th engine,  $\dot{h}_{e_i}$  the rate of change of the angular momentum of the  $i$ th engine,  $I_{e_i}$  the inertia tensor for the  $i$ th engine,  $\omega_{e_i}$  the rotational velocity of the  $i$ th engine, and  $\omega$  the total rotational velocity of the vehicle given by

$$\omega = [p \quad q \quad r]^T$$

If it is assumed that the angular momentum of the engine is constant, then

$$\dot{h}_{e_i} = 0$$

and the equation simplifies to

$$\tau_{g_i} = \omega \times (I_{e_i} \omega_{e_i})$$

Two terms,  $I_{e_i}$  and  $\omega_{e_i}$ , remain to be defined in the equation for the gyroscopic moment produced by the  $i$ th engine. Once again, simplifying assumptions are made. It is assumed that the inertia tensor of the engine contains a single nonzero entry,

$$I'_{e_i} = \begin{bmatrix} I_{x_{e_i}} & 0 & 0 \\ 0 & 0 & 0 \\ 0 & 0 & 0 \end{bmatrix}$$

where  $I_{x_{e_i}}$  is the inertia of the  $i$ th engine at the location of the  $i$ th engine, oriented with the local  $x$  axis coincident with the rotational velocity of the engine. The rotational velocity of the engine has components in the  $x$ ,  $y$ , and  $z$  body axes ( $p_{e_i}$ ,  $q_{e_i}$ , and  $r_{e_i}$ , respectively) so that

$$\omega_{e_i} = (p_{e_i} \quad q_{e_i} \quad r_{e_i})^T$$

where

$$p_{e_i} = |\omega_{e_i}| \cos \epsilon_i \cos \xi_i$$

$$q_{e_i} = |\omega_{e_i}| \cos \epsilon_i \sin \xi_i$$

$$r_{e_i} = - |\omega_{e_i}| \sin \epsilon_i$$

with  $|\omega_{e_i}|$  being the total angular velocity of the  $i$ th engine.

The engine inertia tensor must be defined in the vehicle body axis system and at the vehicle center of gravity. This is done in three steps. The first two steps involve rotating the engine inertia tensor into a coordinate system orthogonal to the aircraft body axis system, while the third step involves defining the engine inertia tensor about the vehicle center of gravity rather than about the center of gravity of the engine itself. First, the  $i$ th engine inertia tensor is rotated through an angle  $\epsilon_i$  about the local  $y$  axis so that the new inertia tensor is oriented with its local  $x$ - $y$  body axis plane parallel to the  $x$ - $y$  body axis plane of the vehicle. The second step requires a rotation through an angle  $\xi_i$  about the local  $z$  axis so that the local  $x$ ,  $y$ , and  $z$  axes are orthogonal to the  $x$ ,  $y$ , and  $z$  body axes of the vehicle. As determined by Gainer and Sherwood (1972) and Thelander (1965), this rotation is a similarity transformation that yields a new inertia tensor  $I_{e_i}''$ , so that

$$I_{e_i}'' = R_{\xi_i}^{-1} R_{\epsilon_i}^{-1} I_{e_i} R_{\epsilon_i} R_{\xi_i}$$

where  $R_{\xi}$  and  $R_{\epsilon}$  are axes transformation matrices that perform the previously described rotations through  $\xi$  and  $\epsilon$ , respectively. These matrices are given as

$$R_{\epsilon_i} = \begin{bmatrix} \cos \epsilon_i & 0 & \sin \epsilon_i \\ 0 & 1 & 0 \\ -\sin \epsilon_i & 0 & \cos \epsilon_i \end{bmatrix}$$

$$R_{\xi_i} = \begin{bmatrix} \cos \xi_i & -\sin \xi_i & 0 \\ \sin \xi_i & \cos \xi_i & 0 \\ 0 & 0 & 1 \end{bmatrix}$$

so that

$$R_{\xi_i} R_{\epsilon_i} = \begin{bmatrix} \cos \xi_i \cos \epsilon_i & -\sin \xi_i & \cos \xi_i \sin \epsilon_i \\ \sin \xi_i \cos \epsilon_i & \cos \xi_i & \sin \xi_i \sin \epsilon_i \\ -\sin \epsilon_i & 0 & \cos \epsilon_i \end{bmatrix}$$

Because

$$R_{\epsilon_i}^{-1} = R_{\epsilon_i}^T$$

and

$$R_{\xi_i}^{-1} = R_{\zeta}^T$$

and the matrices are unitary,

$$R_{\epsilon_i}^{-1} R_{\xi_i}^{-1} = R_{\epsilon_i}^T R_{\xi_i}^T = R_{\xi_i} R_{\epsilon_i}^T$$

$$(R_{\xi_i} R_{\epsilon_i})^T = \begin{bmatrix} \cos \xi_i \cos \epsilon_i & \sin \xi_i \cos \epsilon_i & -\sin \epsilon_i \\ -\sin \xi_i & \cos \xi_i & 0 \\ \cos \xi_i \sin \epsilon_i & \sin \xi_i \sin \epsilon_i & \cos \epsilon_i \end{bmatrix}$$

Therefore,

$$I_{e_i} = I_{x_{e_i}} \begin{bmatrix} \cos^2 \epsilon_i \cos^2 \xi_i & \cos^2 \epsilon_i \cos \xi_i \sin \xi_i & -\cos \epsilon_i \sin \epsilon_i \cos \xi_i \\ \cos^2 \epsilon_i \cos \xi_i \sin \xi_i & \sin^2 \xi_i \cos^2 \epsilon_i & -\sin \epsilon_i \cos \epsilon_i \sin \xi_i \\ -\cos \epsilon_i \sin \epsilon_i \cos \xi_i & -\sin \epsilon_i \cos \epsilon_i \sin \xi_i & \sin^2 \epsilon_i \end{bmatrix}$$

The angular momentum of the  $i$ th engine  $h_i$  can now be expressed as

$$h_i = I_{e_i} \omega_{e_i} = [h_{i1} \quad h_{i2} \quad h_{i3}]^T$$

with

$$h_{i1} = p_{e_i} [I_{x_{e_i}} \cos^2 \epsilon_i \cos^2 \xi_i] + q_{e_i} [I_{x_{e_i}} \cos^2 \epsilon_i \cos \xi_i \sin \xi_i] + r_{e_i} [-I_{x_{e_i}} \cos \epsilon_i \sin \epsilon_i \cos^2 \xi_i]$$

$$h_{i2} = p_{e_i} [I_{x_{e_i}} \cos^2 \epsilon_i \cos \xi_i \sin \xi_i] + q_{e_i} [I_{x_{e_i}} \sin^2 \xi_i \cos^2 \epsilon_i] + r_{e_i} [-I_{x_{e_i}} \sin \epsilon_i \cos \epsilon_i \sin \xi_i]$$

$$h_{i3} = p_{e_i} [-I_{x_{e_i}} \cos \epsilon_i \sin \epsilon_i \cos \xi_i] + q_{e_i} [-I_{x_{e_i}} \sin \epsilon_i \cos \xi_i \sin \xi_i] + r_{e_i} [I_{x_{e_i}} \sin^2 \epsilon_i]$$

Thus, the gyroscopic moment induced by the  $i$ th engine  $\tau_{g_i}$  can be expanded to

$$\tau_{g_i} = \begin{bmatrix} qh_{i3} - rh_{i2} \\ rh_{i1} - ph_{i3} \\ ph_{i2} - qh_{i1} \end{bmatrix}$$

and the total moment induced by gyroscopic interaction of the vehicle dynamics and the rotating engine components is

$$\tau_g = \sum_{i=1}^n \tau_{g_i}$$

Engine torque and gyroscopic effects are modeled within the subroutine ENGINE using information provided by the user from the engine modeling subroutine IFENGN. These effects are calculated as incremental moments and are included directly in the equations of motion for both analysis point definition and derivation of the linearized system matrices.



APPENDIX C: OBSERVATION VARIABLE NAMES RECOGNIZED BY LINEAR

This appendix lists all observation variable names recognized by LINEAR except for state and control variable names. If state variables are specified as elements in the observation vector, the alphanumeric descriptor must correspond to the names defined in appendix D of this report. When control variables are to be included in the observation vector, these variables must be identified exactly as they were specified by the user.

The input file is formatted as shown in table 1. The alphanumeric data (measurement) is left-justified in a 5A4 format. The floating point fields (PARAM) are used to define sensor locations not at the center of gravity. The input name specified by the user for an observation variable serves both to identify the observation variable selected within the program itself as well as to identify observation variables on the printed output of LINEAR.

Observation variable	Units	Symbol	Alphanumeric descriptors
Derivatives of state variables			
Roll acceleration	rad/sec <sup>2</sup>	$\dot{p}$	PDOT ROLL ACCELERATION
Pitch acceleration	rad/sec <sup>2</sup>	$\dot{q}$	QDOT PITCH ACCELERATION
Yaw acceleration	rad/sec <sup>2</sup>	$\dot{r}$	RDOT YAW ACCELERATION
Velocity rate	ft/sec <sup>2</sup>	$\dot{V}$	VDOT VELOCITY RATE
Angle-of-attack rate	rad/sec	$\dot{\alpha}$	ALPDOT ALPHA DOT ALPHADOT
Angle-of-sideslip rate	rad/sec	$\dot{\beta}$	BTADOT BETA DOT BETADOT
Pitch attitude rate	rad/sec	$\dot{\theta}$	THADOT THETA DOT
Heading rate	rad/sec	$\dot{\psi}$	PSIDOT PSI DOT
Roll attitude rate	rad/sec	$\dot{\phi}$	PHIDOT PHI DOT

Observation variable	Units	Symbol	Alphanumeric descriptors
Derivatives of state variables (continued)			
Altitude rate	ft/sec	$\dot{h}$	HDOT ALTITUDE RATE
Velocity north	ft/sec	$\dot{x}$	XDOT
Velocity east	ft/sec	$\dot{y}$	YDOT
Accelerations			
x body axis acceleration	g	$a_x$	AX LONGITUDINAL ACCEL X-AXIS ACCELERATION X AXIS ACCELERATION X-BODY AXIS ACCEL X BODY AXIS ACCEL
y body axis acceleration	g	$a_y$	AY Y-AXIS ACCELERATION Y AXIS ACCELERATION Y-BODY AXIS ACCEL Y BODY AXIS ACCEL LATERAL ACCELERATION LAT ACCEL LATERAL ACCEL
z body axis acceleration	g	$a_z$	AZ Z-BODY AXIS ACCEL Z BODY AXIS ACCEL
x body axis accelerometer at vehicle center of gravity	g	$a_{nx}$	ANX X-AXIS ACCELEROMETER X AXIS ACCELEROMETER
y body axis accelerometer at vehicle center of gravity	g	$a_{ny}$	ANY Y-AXIS ACCELEROMETER Y AXIS ACCELEROMETER
z body axis accelerometer at vehicle center of gravity	g	$a_{nz}$	ANZ Z-AXIS ACCELEROMETER Z AXIS ACCELEROMETER

Observation variable	Units	Symbol	Alphanumeric descriptors
Accelerations (continued)			
normal acceleration	g	$a_n$	AN NORMAL ACCELERATION NORMAL ACCEL GS G'S
*x body axis accelerometer not at vehicle center of gravity	g	$a_{nx,i}$	AX,I ANX,I
*y body axis accelerometer not at vehicle center of gravity	g	$a_{ny,i}$	AY,I ANY,I
*z body axis accelerometer not at vehicle center of gravity	g	$a_{nz,i}$	AZ,I ANZ,I
*normal accelerometer not at vehicle center of gravity	g	$a_{n,i}$	AN,I
load factor	Dimension- less	n	N LOAD FACTOR
Air data parameters			
Speed of sound	ft/sec	a	A SPEED OF SOUND
†Reynolds number	Dimension- less	Re	RE REYNOLDS NUMBER
Reynolds number per unit length	ft <sup>-1</sup>	Re'	RE PRIME R/LENGTH R/FEET R/UNIT LENGTH
Mach number	Dimension- less	M	M MACH AMCH

Observation variable	Units	Symbol	Alphanumeric descriptors
Air data parameters (continued)			
Dynamic pressure	lb/ft <sup>2</sup>	$\bar{q}$	QBAR DYNAMIC PRESSURE
Impact pressure	lb/ft <sup>2</sup>	$q_c$	QC IMPACT PRESSURE DIFFERENTIAL PRESSURE
Static pressure	lb/ft <sup>2</sup>	$P_a$	PA STATIC PRESSURE FREESTREAM PRESSURE
Impact/ambient pressure ratio	Dimensionless	$q_c/P_a$	QC/PA QC/P
Total pressure	lb/ft <sup>2</sup>	$P_t$	PT TOTAL PRESSURE
Temperature	deg absolute	T	TEMP TEMPERATURE FREESTREAM TEMPERATURE
Total temperature	deg absolute	$T_t$	TOTAL TEMPERATURE
Equivalent airspeed	knot	$V_e$	VEAS EQUIVALENT AIRSPEED KEAS
Calibrated airspeed	knot	$V_c$	VCAS CALIBRATED AIRSPEED KCAS
Flightpath-related parameters			
Flightpath angle	rad	$\gamma$	GAM GAMMA FLIGHT PATH ANGLE GLIDE PATH ANGLE GLIDE SLOPE
Flightpath acceleration	g	fpa	FPA FLIGHT PATH ACCEL
Flightpath angle rate	rad/sec	$\dot{\gamma}$	GAMMA DOT GAMMADOT

Observation variable	Units	Symbol	Alphanumeric descriptors
Flightpath-related parameters (continued)			
Vertical acceleration	ft/sec <sup>2</sup>	$\ddot{h}$	VERTICAL ACCELERATION HDOTDOT H-DOT-DOT HDOT-DOT
Scaled altitude rate	ft/sec	$\dot{h}/57.3$	H-DOT/57.3 HDOT / 57.3
Energy-related terms			
Specific energy	ft	$E_s$	ES E-SUB-S SPECIFIC ENERGY
Specific power	ft/sec	$P_s$	PS P-SUB-S SPECIFIC POWER SPECIFIC THRUST
Force parameters			
Lift force	lb	L	LIFT
Drag force	lb	D	DRAG
Normal force	lb	N	NORMAL FORCE
Axial force	lb	A	AXIAL FORCE
Body axis parameters			
x body axis velocity	ft/sec	u	UB X-BODY AXIS VELOCITY X BODY AXIS VELOCITY X-BODY AXIS VEL X BODY AXIS VEL U-BODY U BODY
y body axis velocity	ft/sec	v	VB Y-BODY AXIS VELOCITY Y BODY AXIS VELOCITY Y-BODY AXIS VEL Y BODY AXIS VEL V-BODY V BODY

Observation variable	Units	Symbol	Alphanumeric descriptors
Body axis parameters			
z body axis velocity	ft/sec	w	WB Z-BODY AXIS VELOCITY Z BODY AXIS VELOCITY Z-BODY AXIS VEL Z BODY AXIS VEL W-BODY W-BODY
Rate of change of velocity in x body axis	ft/sec <sup>2</sup>	$\dot{u}$	UBDOT UB DOT
Rate of change of velocity in y body axis	ft/sec <sup>2</sup>	$\dot{v}$	VBDOT VB DOT
Miscellaneous measurements not at vehicle center of gravity			
Rate of change of velocity in z body axis	ft/sec <sup>2</sup>	$\dot{w}$	WBDOT WB DOT
*Angle of attack not at vehicle center of gravity	rad	$\alpha_i$	ALPHA,I ALPHA INSTRUMENT AOA INSTRUMENT
*Angle of sideslip not at vehicle center of gravity	rad	$\beta_i$	BETA,I BETA INSTRUMENT SIDESLIP INSTRUMENT
*Altitude instrument not at vehicle center of gravity	ft	$h_i$	H,I ALTITUDE INSTRUMENT
*Altitude rate instrument not at vehicle center of gravity	ft/sec	$\dot{h}_i$	HDOT,I
Other miscellaneous parameters			
Vehicle total angular momentum	slug-ft <sup>2</sup> / sec <sup>2</sup>	T	ANGULAR MOMENTUM ANG MOMENTUM
Stability axis roll rate	rad/sec	$p_s$	STAB AXIS ROLL RATE

Observation variable	Units	Symbol	Alphanumeric descriptors
Other miscellaneous parameters (continued)			
Stability axis pitch rate	rad/sec	$q_s$	STAB AXIS PITCH RATE
Stability axis yaw rate	rad/sec	$r_s$	STAB AXIS YAW RATE

\*All parameters with an asterisk are for measurements at some point other than the vehicle center of gravity. The program LINEAR uses the quantities defined in the first three floating point fields as definitions of the location of the sensor with respect to the vehicle center of gravity. The three parameters define the x body, y body, and z body locations, in that order, of the sensor. The units of these offsets from the vehicle center of gravity are defined in units of feet.

†Reynolds number is defined in terms of an arbitrary unit of length that is input by the user. This length is input using the first floating point field; however, if no value is input,  $\bar{c}$  is used as the default value.

APPENDIX D: STATE VARIABLE NAMES RECOGNIZED BY LINEAR

The alphanumeric descriptors specifying state variables that are recognized by LINEAR are listed in this appendix. In the input file, the field containing these descriptors uses a 5A4 format, and all characters are left justified. The input alphanumeric descriptor specified by the user serves both to identify the state variable selected by the user within the program itself as well as to identify state variables on the printed output of LINEAR as described in the Output Files section.

State variable	Units	Symbol	Alphanumeric descriptors
Roll rate	rad/sec	p	P ROLL RATE
Pitch rate	rad/sec	q	Q PITCH RATE
Yaw rate	rad/sec	r	R YAW RATE
Velocity	ft/sec	V	V VELOCITY VEL VTOT
Angle of attack	rad	$\alpha$	ALP ALPHA ANGLE OF ATTACK
Sideslip angle	rad	$\beta$	BTA BETA SIDESLIP ANGLE ANGLE OF SIDESLIP
Pitch attitude	rad	$\theta$	THA THETA PITCH ATTITUDE
Heading	rad	$\psi$	PSI HEADING HEADING ANGLE
Roll attitude	rad	$\phi$	PHI ROLL ATTITUDE BANK ANGLE
Altitude	ft	h	H ALTITUDE
Displacement north	ft	x	X
Displacement east	ft	y	Y



APPENDIX E: ANALYSIS POINT DEFINITION IDENTIFIERS

Analysis point definition options are selected using alphanumeric descriptors. These descriptors are the first record read for each analysis case. All these descriptors are read using a 5A4 format. The following list associates the analysis point definition options with their alphanumeric descriptors:

Analysis point definition option	Alphanumeric descriptors
Untrimmed	UNTRIMMED NO TRIM NONE NOTRIM
Straight-and-level	STRAIGHT AND LEVEL WINGS LEVEL LEVEL FLIGHT
Pushover-pullup	PUSHOVER AND PULLUP PULLUP PUSH-OVER/PULL-UP PUSH-OVER / PULL-UP PUSHOVER / PULLUP PUSHOVER PULLUP PUSH OVER PULL UP PUSHOVER PUSHPULL
Level turn	LEVEL TURN WINDUP TURN
Thrust stabilized turn	THRUST STABILIZED TURN THRUST LIMITED TURN FIXED THROTTLE TURN FIXED THRUST TURN
Beta	BETA SIDESLIP
Specific power	SPECIFIC POWER PS P-SUB-S

Each of these analysis point definitions except the untrimmed, beta, and specific power options has two suboptions associated with it. The suboptions are requested using alphanumeric descriptors read using an A4 format. These suboptions are defined

in the Analysis Point Definition section of this report. The following list defines these suboptions and the alphanumeric descriptors associated with each:

Analysis point definition suboptions	Alphanumeric descriptors
Straight-and-level:	
Alpha-trim	ALP ALPH ALPHA
Mach-trim	MACH AMCH
Pushover-pullup:	
Alpha-trim	ALP ALPH ALPHA
Load-factor-trim	LOAD GS G'S AN
Level turn:	
Alpha-trim	ALP ALPH ALPHA
Load-factor-trim	LOAD GS G'S AN
Thrust stabilized turn:	
Alpha-trim	ALP ALPH ALPHA
Load-factor-trim	LOAD GS G'S AN

APPENDIX F: EXAMPLE INPUT FILE

The following listing is an example of an input file to LINEAR. This file was used with the example subroutines listed in appendix J to generate the analysis and line printer files shown in appendixes H and I, respectively. The formats specified in table 1 would be the same whether each type of input has its own file or all of the data is in one file.

USER'S GUIDE

```

6.080000E+02 4.280000E+01 1.595000E+01 4.500000E+04
2.870000E+04 1.651000E+05 1.879000E+05-5.200000E+02 0.      0.
0.      0.      0.      CCALC WILL CALCULATE CG CORRECTIONS
-1.000000E+01 4.000000E+01
      4STAN      RADI
ALPHA
Q
THETA
VEL
      3
ELEVATOR      5
THROTTLE      12
SPEED BRAKE   10
      2STAN
AN
AY
-2.900E+00 5.430E+00-4.000E+00 4.000E+00-3.250E+00 3.250E+00-1.000E+00 1.000E+00
  0 ADDITIONAL SURFACES
WINDUP TURN
ALPHA
H      20000.0
MACH   0.90
AN     3.00
BETA   0.0
NEXT
LEVEL FLIGHT
ALPHA
H      20000.0
MACH   0.9
GAMMA  10.0
END

```

This input file is for a case called USER'S GUIDE (record 1). The project title is input from the terminal as described in the Data Input section. Record 2 specifies the mass and geometric properties of the vehicle as

$$S = 608 \text{ ft}^2$$

$$b = 42.8 \text{ ft}$$

$$\bar{c} = 15.95 \text{ ft}$$

$$w = 45,000 \text{ lbs}$$

Record 3 defines the moments and products of inertia of the vehicle as

$$I_x = 28,700 \text{ slug-ft}^2$$

$$I_y = 165,100 \text{ slug-ft}^2$$

$$I_z = 187,900 \text{ slug-ft}^2$$

$$I_{xz} = -520 \text{ slug-ft}^2$$

$$I_{xy} = 0.0 \text{ slug-ft}^2$$

$$I_{yz} = 0.0 \text{ slug-ft}^2$$

Record 4 defines the location of the aerodynamic reference point to be coincident with the vehicle center of gravity of the nonlinear aerodynamic model by setting

$$\Delta x = 0.0 \text{ ft}$$

$$\Delta y = 0.0 \text{ ft}$$

$$\Delta z = 0.0 \text{ ft}$$

Record 4 also specifies that LINEAR should not use its internal model to make corrections for the offset in the vehicle center of gravity from the aerodynamic reference point because the aerodynamic model includes such corrections.

Record 5 defines the angle-of-attack range of the aerodynamic model.

Record 6 specifies that there will be four state variables in the linear model, that the formulation of the state equation will be in the standard form ( $\dot{\mathbf{x}} = \mathbf{A} \mathbf{x} + \mathbf{B} \mathbf{u}$ ), and that the nondimensional stability and control derivatives with respect to angle of attack and angle of sideslip should be scaled in radians<sup>-1</sup>. The next four records define the output formulation of the state vector to be

$$\mathbf{x} = \begin{bmatrix} \alpha \\ q \\ \theta \\ v \end{bmatrix}$$

Record 11 specifies that the linear model will have three parameters in the control vector. The following three records (12 to 14) specify that

$$\mathbf{u} = \begin{bmatrix} \text{elevator} \\ \text{throttle} \\ \text{speed brake} \end{bmatrix}$$

and that elevator, throttle, and speed brake are located in DC(5), DC(12), and DC(10) of the /CONTROL/ common block.

Record 15 specifies that two observation variables will be used, and that the observation equation will be in the standard form,

$$y = Hx + Fu$$

The next two records (16 and 17) define the elements of the output vector to be

$$y = \begin{bmatrix} a_n \\ a_y \end{bmatrix}$$

Record 18 specifies the ranges for the trim parameters DES, DAS, DRS, and THRSTX, used to trim the longitudinal, lateral, and directional axes, and thrust, respectively. The ranges for these parameters are defined by record 20 to be

$$\begin{aligned} -2.9 &< \text{DES} < 5.43 \\ -4.0 &< \text{DAS} < 4.0 \\ -3.25 &< \text{DRS} < 3.25 \\ -1.0 &< \text{THRSTX} < 1.0 \end{aligned}$$

The first three parameters essentially represent stick and rudder positions and are so specified because of the implementation of the subroutine UCNTRL (discussed in app. J). The thrust trim parameter is specified in this manner because of the implementation of UCNTRL. Speed brake is scheduled when THRSTX < 0 and thrust is commanded when THRSTX > 0.

Record 19 specifies that no additional control surfaces are to be set.

The next seven records (20 to 26) define an analysis point option. These records request a level turn trim option at

$$h = 20,000 \text{ ft}$$

$$M = 0.9$$

$$a_n = 3.0 \text{ g}$$

and

$$\beta = 0.0^\circ$$

The second record of this set (record 21) indicates which level turn suboption is requested. The alphanumeric descriptor ALPHA indicates that angle of attack is to be varied until the specified 3.0-g turn is achieved. The final record of this analysis point option definition set contains the keyword NEXT to indicate both an end to the current analysis point option definition and that another analysis point option definition follows.

The final six records (records 27 to 32) define a straight-and-level analysis point option at

$$h = 20,000 \text{ ft}$$

$$M = 0.9$$

and

$$\gamma = 10.0^\circ$$

The second record of this set (record 28) identifies the Alpha Trim suboption in which angle of attack is varied until trim is achieved at the specified condition. The final record of this set contains the keyword END to indicate the termination of the current analysis point definition as well as the termination of input cases.

APPENDIX G: EXAMPLE LINEARIZED STABILITY AND CONTROL DERIVATIVE FILE

STABILITY AND CONTROL DERIVATIVES FOR CASE #1  
 LINEARIZER TEST AND DEMONSTRATION CASES

FOR THE PROJECT:  
 F-15 SIMULATION

REFERENCE ALTITUDE = 2.0000D+04  
 REFERENCE MACH = 9.0000D-01

ANGLES ARE IN RADIANS FOR OUTPUT  
 WARNING!!!! DERIVATIVES WITH RESPECT TO MACH WILL BE USED.  
 VELOCITY DERIVATIVES WILL BE COMPUTED FROM MACH DERIVATIVES.

THERE ARE 3 CONTROL SURFACES

ROLL MOMENT DERIVATIVES

CLO		-4.02966D-05
ROLL RATE (RAD/SEC)		-2.00000D-01
PITCH RATE (RAD/SEC)		.00000D+00
YAW RATE (RAD/SEC)		1.50990D-01
VELOCITY (FT/SEC)		-1.26696D-07
MACH NUMBER		-1.31375D-04
ALPHA (RAD)		.00000D+00
BETA (RAD)		-1.33450D-01
ALTITUDE (FT)		.00000D+00
ALPHA DOT (RAD/SEC)		.00000D+00
BETA DOT (RAD/SEC)		.00000D+00
ELEVATOR	5	.00000D+00
THROTTLE	12	.00000D+00
SPEED BRAKE	10	.00000D+00

PITCH MOMENT DERIVATIVES

CM0		4.22040D-02
ROLL RATE (RAD/SEC)		.00000D+00
PITCH RATE (RAD/SEC)		3.89527D+00
YAW RATE (RAD/SEC)		.00000D+00
VELOCITY (FT/SEC)		-3.28490D-06
MACH NUMBER		-3.40620D-03
ALPHA (RAD)		-1.68819D-01
BETA (RAD)		.00000D+00
ALTITUDE (FT)		.00000D+00
ALPHA DOT (RAD/SEC)		-1.18870D+01
BETA DOT (RAD/SEC)		.00000D+00
ELEVATOR	5	-6.95281D-01
THROTTLE	12	.00000D+00
SPEED BRAKE	10	-4.17500D-01

YAW MOMENT DERIVATIVES

CNO		2.25747D-04
ROLL RATE (RAD/SEC)		-3.37217D-02
PITCH RATE (RAD/SEC)		.00000D+00
YAW RATE (RAD/SEC)		-4.04710D-01
VELOCITY (FT/SEC)		3.21400D-07
MACH NUMBER		3.33268D-04
ALPHA (RAD)		.00000D+00
BETA (RAD)		1.29960D-01
ALTITUDE (FT)		.00000D+00
ALPHA DOT (RAD/SEC)		.00000D+00
BETA DOT (RAD/SEC)		.00000D+00
ELEVATOR	5	.00000D+00
THROTTLE	12	.00000D+00
SPEED BRAKE	10	.00000D+00

DRAG FORCE DERIVATIVES

CD0		1.08760D-02
ROLL RATE (RAD/SEC)		.00000D+00
PITCH RATE (RAD/SEC)		.00000D+00
YAW RATE (RAD/SEC)		.00000D+00
VELOCITY (FT/SEC)		.00000D+00
MACH NUMBER		.00000D+00
ALPHA (RAD)		3.72570D-01
BETA (RAD)		.00000D+00
ALTITUDE (FT)		.00000D+00
ALPHA DOT (RAD/SEC)		.00000D+00
BETA DOT (RAD/SEC)		.00000D+00
ELEVATOR	5	4.38318D-02
THROTTLE	12	.00000D+00
SPEED BRAKE	10	6.49355D-02

LIFT FORCE DERIVATIVES

CLFT0		1.57360D-01
ROLL RATE (RAD/SEC)		.00000D+00
PITCH RATE (RAD/SEC)		-1.72315D+01
YAW RATE (RAD/SEC)		.00000D+00
VELOCITY (FT/SEC)		1.45286D-05
MACH NUMBER		1.50651D-02
ALPHA (RAD)		4.87061D+00
BETA (RAD)		.00000D+00
ALTITUDE (FT)		.00000D+00
ALPHA DOT (RAD/SEC)		1.72315D+01
BETA DOT (RAD/SEC)		.00000D+00
ELEVATOR	5	5.72950D-01
THROTTLE	12	.00000D+00
SPEED BRAKE	10	3.74913D-02



SIDE FORCE DERIVATIVES

CY0		5.32725D-04
ROLL RATE (RAD/SEC)		.00000D+00
PITCH RATE (RAD/SEC)		.00000D+00
YAW RATE (RAD/SEC)		.00000D+00
VELOCITY (FT/SEC)		.00000D+00
MACH NUMBER		.00000D+00
ALPHA (RAD)		.00000D+00
BETA (RAD)		-9.74030D-01
ALTITUDE (FT)		.00000D+00
ALPHA DOT (RAD/SEC)		.00000D+00
BETA DOT (RAD/SEC)		.00000D+00
ELEVATOR	5	.00000D+00
THROTTLE	12	.00000D+00
SPEED BRAKE	10	.00000D+00

---

---

STABILITY AND CONTROL DERIVATIVES FOR CASE #2  
LINEARIZER TEST AND DEMONSTRATION CASES

FOR THE PROJECT:  
F-15 SIMULATION

REFERENCE ALTITUDE = 2.0000D+04  
REFERENCE MACH = 9.0000D-01

ANGLES ARE IN RADIANS FOR OUTPUT  
WARNING!!!! DERIVATIVES WITH RESPECT TO MACH WILL BE USED.  
VELOCITY DERIVATIVES WILL BE COMPUTED FROM MACH DERIVATIVES.

THERE ARE 3 CONTROL SURFACES

ROLL MOMENT DERIVATIVES

CL0		1.25377D-16
ROLL RATE (RAD/SEC)		-2.00000D-01
PITCH RATE (RAD/SEC)		.00000D+00
YAW RATE (RAD/SEC)		1.50990D-01
VELOCITY (FT/SEC)		.00000D+00
MACH NUMBER		.00000D+00
ALPHA (RAD)		.00000D+00
BETA (RAD)		-1.33450D-01
ALTITUDE (FT)		.00000D+00
ALPHA DOT (RAD/SEC)		.00000D+00
BETA DOT (RAD/SEC)		.00000D+00
ELEVATOR	5	.00000D+00
THROTTLE	12	.00000D+00
SPEED BRAKE	10	.00000D+00

PITCH MOMENT DERIVATIVES

CM0		4.22040D-02
ROLL RATE (RAD/SEC)		.00000D+00
PITCH RATE (RAD/SEC)		3.89530D-00
YAW RATE (RAD/SEC)		.00000D+00
VELOCITY (FT/SEC)		-7.79749D-10
MACH NUMBER		-8.08541D-07
ALPHA (RAD)		-1.68819D-01
BETA (RAD)		.00000D+00
ALTITUDE (FT)		.00000D+00
ALPHA DOT (RAD/SEC)		-1.18870D+01
BETA DOT (RAD/SEC)		.00000D+00
ELEVATOR	5	-6.95279D-01
THROTTLE	12	.00000D+00
SPEED BRAKE	10	-4.17500D-01

YAW MOMENT DERIVATIVES

CNO		1.22535D-16
ROLL RATE (RAD/SEC)		-3.37217D-02
PITCH RATE (RAD/SEC)		.00000D+00
YAW RATE (RAD/SEC)		-4.04710D-01
VELOCITY (FT/SEC)		.00000D+00
MACH NUMBER		.00000D+00
ALPHA (RAD)		.00000D+00
BETA (RAD)		1.29960D-01
ALTITUDE (FT)		.00000D+00
ALPHA DOT (RAD/SEC)		.00000D+00
BETA DOT (RAD/SEC)		.00000D+00
ELEVATOR	5	.00000D+00
THROTTLE	12	.00000D+00
SPEED BRAKE	10	.00000D+00

DRAG FORCE DERIVATIVES

CDO		1.08760D-02
ROLL RATE (RAD/SEC)		.00000D+00
PITCH RATE (RAD/SEC)		.00000D+00
YAW RATE (RAD/SEC)		.00000D+00
VELOCITY (FT/SEC)		.00000D+00
MACH NUMBER		.00000D+00
ALPHA (RAD)		3.72570D-01
BETA (RAD)		.00000D+00
ALTITUDE (FT)		.00000D+00
ALPHA DOT (RAD/SEC)		.00000D+00
BETA DOT (RAD/SEC)		.00000D+00
ELEVATOR	5	4.38313D-02
THROTTLE	12	.00000D+00
SPEED BRAKE	10	6.49346D-02

LIFT FORCE DERIVATIVES

CLFT0		1.57360D-01
ROLL RATE (RAD/SEC)		.00000D+00
PITCH RATE (RAD/SEC)		-1.72320D+01
YAW RATE (RAD/SEC)		.00000D+00
VELOCITY (FT/SEC)		3.59263D-09
MACH NUMBER		3.72529D-06
ALPHA (RAD)		4.87061D+00
BETA (RAD)		.00000D+00
ALTITUDE (FT)		.00000D+00
ALPHA DOT (RAD/SEC)		1.72320D+01
BETA DOT (RAD/SEC)		.00000D+00
ELEVATOR	5	5.72961D-01
THROTTLE	12	.00000D+00
SPEED BRAKE	10	3.74913D-02

SIDE FORCE DERIVATIVES

CY0		4.15737D-16
ROLL RATE (RAD/SEC)		.00000D+00
PITCH RATE (RAD/SEC)		.00000D+00
YAW RATE (RAD/SEC)		.00000D+00
VELOCITY (FT/SEC)		.00000D+00
MACH NUMBER		.00000D+00
ALPHA (RAD)		.00000D+00
BETA (RAD)		-9.74030D-01
ALTITUDE (FT)		.00000D+00
ALPHA DOT (RAD/SEC)		.00000D+00
BETA DOT (RAD/SEC)		.00000D+00
ELEVATOR	5	.00000D+00
THROTTLE	12	.00000D+00
SPEED BRAKE	10	.00000D+00

---

APPENDIX H: EXAMPLE OUTPUT ANALYSIS FILE

The following is an example analysis file. This file was produced using the example input file listed in appendix F and the example user-supplied subroutines listed in appendix J.

---

LINEARIZER TEST AND DEMONSTRATION CASES  
USER'S GUIDE

TEST CASE # \*\*\*\*\* 1  
X - DIMENSION = 4          U - DIMENSION = 3          Y - DIMENSION = 2  
STATE EQUATION FORMULATION:          STANDARD  
OBSERVATION EQUATION FORMULATION:      STANDARD

STATE VARIABLES

ALPHA                    = 0.465695D-01      RADIANS  
Q                        = 0.921683D-01      RADIANS/SECOND  
THETA                    = 0.159885D-01      RADIANS  
VEL                      = 0.933232D+03      FEET/SECOND

CONTROL VARIABLES

ELEVATOR                = 0.538044D-01  
THROTTLE                = 0.214105D+00  
SPEED BRAKE             = 0.000000D+00

DYNAMIC INTERACTION VARIABLES

X-BODY AXIS FORCE = 0.134742D+06      POUNDS  
Y-BODY AXIS FORCE = 0.102657D+05      POUNDS  
Z-BODY AXIS FORCE = 0.938155D-03      POUNDS  
PITCHING MOMENT    = 0.680525D+02      FOOT-POUNDS  
ROLLING MOMENT     = 0.000000D+00      FOOT-POUNDS  
YAWING MOMENT      = -.212007D+02      FOOT-POUNDS

OBSERVATION VARIABLES

AN                      = 0.300163D+01      GS  
AY                      = 0.941435D+00      GS

A-MATRIX FOR:  $DX / DT = A * X + B * U + D * V$

-0.121436D+01 0.100000D+01 0.136756D-02-0.121605D-03  
-0.147423D+01-0.221451D+01-0.450462D-02 0.294019D-03  
0.000000D+00 0.331812D+00 0.000000D+00 0.000000D+00  
-0.790853D+02 0.000000D+00-0.320822D+02-0.157297D-01

B-MATRIX FOR:  $DX / DT = A * X + B * U + D * V$

0.141961D+00-0.164948D-02-0.928933D-02  
0.220778D+02 0.543324D-02-0.135074D+02  
0.000000D+00 0.000000D+00 0.000000D+00  
0.105186D+02 0.342817D+02-0.155832D+02

D-MATRIX FOR:  $DX / DT = A * X + B * U + D * V$

0.343642D-07 0.000000D+00 0.737378D-06 0.000000D+00 0.000000D+00  
0.113192D-06 0.000000D+00-0.242885D-05 0.605694D-05 0.000000D+00  
0.000000D+00 0.000000D+00 0.000000D+00 0.000000D+00 0.000000D+00  
0.714203D-03 0.398492D-06 0.332842D-04 0.000000D+00 0.000000D+00  
  
0.000000D+00  
0.000000D+00  
0.000000D+00  
0.000000D+00

H-MATRIX FOR:  $Y = H * X + F * U + E * V$

0.351752D+02 0.277556D-16 0.150046D-02 0.640771D-02  
0.000000D+00 0.000000D+00-0.150534D-01 0.446789D-10

F-MATRIX FOR:  $Y = H * X + F * U + E * V$

0.412845D+01-0.180978D-02 0.291699D+00  
0.000000D+00 0.000000D+00 0.000000D+00

E-MATRIX FOR:  $Y = H * X + F * U + E * V$

-0.377037D-07 0.000000D+00-0.214132D-04 0.000000D+00 0.000000D+00  
0.000000D+00 0.222222D-04 0.000000D+00 0.000000D+00 0.000000D+00  
0.000000D+00  
0.000000D+00

TEST CASE \*\*\*\*\* 2  
 X - DIMENSION = 4 U - DIMENSION = 3 Y - DIMENSION = 2  
 STATE EQUATION FORMULATION: STANDARD  
 OBSERVATION EQUATION FORMULATION: STANDARD

STATE VARIABLES

ALPHA = -.126650D-01 RADIANS  
 Q = 0.000000D+00 RADIANS/SECOND  
 THETA = 0.161868D+00 RADIANS  
 VEL = 0.933232D+03 FEET/SECOND

CONTROL VARIABLES

ELEVATOR = 0.637734D-01  
 THROTTLE = 0.225092D+00  
 SPEED BRAKE = 0.000000D+00

DYNAMIC INTERACTION VARIABLES

X-BODY AXIS FORCE = 0.443769D+05 POUNDS  
 Y-BODY AXIS FORCE = 0.300494D+04 POUNDS  
 Z-BODY AXIS FORCE = 0.445795D-09 POUNDS  
 PITCHING MOMENT = -.528481D-11 FOOT-POUNDS  
 ROLLING MOMENT = 0.000000D+00 FOOT-POUNDS  
 YAWING MOMENT = 0.114239D-10 FOOT-POUNDS

OBSERVATION VARIABLES

AN = 0.985228D+00 GS  
 AY = 0.990655D-14 GS

A-MATRIX FOR:  $DX / DT = A * X + B * U + D * V$

0.120900D+01 0.100000D+01 -0.575730D-02 -0.701975D-04  
 0.149189D+01 -0.221451D+01 0.189640D-01 0.231368D-03  
 0.000000D+00 0.100000D+01 0.000000D+00 0.000000D+00  
 0.576868D+02 0.000000D+00 -0.316251D+02 -0.460435D-02

B-MATRIX FOR:  $DX / DT = A * X + B * U + D * V$

0.141961D+00 0.448742D-03 -0.928932D-02  
 0.220778D+02 -0.147812D-02 -0.135074D+02  
 0.000000D+00 0.000000D+00 0.000000D+00  
 0.105186D+02 0.343162D+02 -0.155832D+02

D-MATRIX FOR:  $DX / DT + A * X + B * U + D * V$

0.934880D-08 0.000000D+00 0.738119D-06 0.000000D+00 0.000000D+00  
0.307941D-07 0.000000D+00-0.243129D-05 0.605694D-05 0.000000D+00  
0.000000D+00 0.000000D+00 0.000000D+00 0.000000D+00 0.000000D+00  
0.714920D-03 0.000000D+00-0.905497D-05 0.000000D+00 0.000000D+00  
0.000000D+00  
0.000000D+00  
0.000000D+00  
0.000000D+00

H-MATRIX FOR:  $Y = H * X + F * U$

0.350424D+02 0.277556D-16-0.632314D-02 0.203434D-02  
0.000000D+00 0.000000D+00 0.000000D+00 0.212306D-16

F-MATRIX FOR:  $Y = H * X + F * U$

0.411323D+01 0.492845D-03 0.263288D+00  
0.000000D+00 0.000000D+00 0.000000D+00

E-MATRIX FOR:  $Y + H * X + F * U + E * V$

0.102676D-07 0.000000D+00-0.214116D-04 0.000000D+00 0.000000D+00  
0.000000D+00 0.222222D-04 0.000000D+00 0.000000D+00 0.000000D+00  
0.000000D+00  
0.000000D+00

---



APPENDIX I: EXAMPLE PRINTER OUTPUT FILE

The following listings are printer output files generated by LINEAR using the example input file in appendix F and the example user-supplied subroutines in appendix J.

---

GEOMETRY AND MASS DATA FOR:  
LINEARIZER TEST AND DEMONSTRATION CASES

FOR THE PROJECT:  
USER'S GUIDE

WING AREA	608.000 (FT**2)
WING SPAN	42.800 (FT)
MEAN CHORD	15.950 (FT)
VEHICLE WEIGHT	45000.000 (LB)
IX	28700.000 (SLUG-FT**2)
IY	165100.000 (SLUG-FT**2)
IZ	187900.000 (SLUG-FT**2)
IXZ	-520.000 (SLUG-FT**2)
IXY	0.000 (SLUG-FT**2)
IYZ	0.000 (SLUG-FT**2)

VECTOR DEFINING REFERENCE POINT OF AERODYNAMIC MODEL  
WITH RESPECT TO VEHICLE CENTER OF GRAVITY:

DELTA X	0.000 (FT)
DELTA Y	0.000 (FT)
DELTA Z	0.000 (FT)

FORCE AND MOMENT COEFFICIENT CORRECTIONS FROM THE REFERENCE POINT OF  
THE BASIC AERODYNAMIC MODEL TO THE VEHICLE CENTER OF GRAVITY ARE  
INTERNALLY CALCULATED IN LINEAR.

MINIMUM ANGLE OF ATTACK	-10.000 (DEG)
MAXIMUM ANGLE OF ATTACK	40.000 (DEG)

PARAMETERS USED IN THE STATE VECTOR FOR:  
LINEARIZER TEST AND DEMONSTRATION CASES

FOR THE PROJECT:  
USER'S GUIDE

ALPHA  
Q  
THETA  
VEL

THE STANDARD FORMULATION OF THE STATE EQUATION  
HAS BEEN SELECTED. THE FORM OF THE EQUATION IS:

$$DX/DT = A * X + B * U$$

SURFACES TO BE USED FOR THE CONTROL VECTOR FOR:  
LINEARIZER TEST AND DEMONSTRATION CASES

FOR THE PROJECT:  
USER'S GUIDE

LOCATION IN /CONTROL/

ELEVATOR	5
THROTTLE	12
SPEED BRAKE	10

PARAMETERS USED IN THE OBSERVATION VECTOR FOR:  
LINEARIZER TEST AND DEMONSTRATION CASES

FOR THE PROJECT:  
USER'S GUIDE

AN  
AY

THE STANDARD FORMULATION OF THE OBSERVATION EQUATION  
HAS BEEN SELECTED. THE FORM OF THE EQUATION IS:

$$Y = H * X + F * U$$

LIMITS FOR TRIM OUTPUT PARAMETERS:

	<u>MINIMUM</u>	<u>MAXIMUM</u>
PITCH AXIS PARAMETER	-2.900	5.430
ROLL AXIS PARAMETER	-4.000	4.000
YAW AXIS PARAMETER	-3.250	3.250
THRUST PARAMETER	-1.000	1.000

NO ADDITIONAL SURFACES TO BE SET WERE DEFINED

TRIM CONDITIONS FOR CASE # 1  
LINEARIZER TEST AND DEMONSTRATION CASES

FOR THE PROJECT:  
USER'S GUIDE

LEVEL TURN WHILE VARYING ALPHA

TRIM ACHIEVED

COEFFICIENT OF LIFT	=	0.40144
COEFFICIENT OF DRAG	=	0.03058
LIFT (LBS)	=	134741.68807
DRAG (LBS)	=	10265.70661
ALTITUDE (FT)	=	20000.00000
MACH	=	0.90000
VELOCITY (FT/SEC)	=	933.23196
EQUIVALENT AIRSPEED (KTS)	=	403.42303
SPEED OF SOUND (FT/SEC)	=	1036.92440
GRAVITATIONAL ACCEL (FT/SEC**2)	=	32.11294
NORMAL ACCELERATION (G-S)	=	3.00163
LOAD FACTOR	=	2.99995
DYNAMIC PRESSURE (LBS/FT**2)	=	552.05302
DENSITY (SLUG/FT**3)	=	0.00126774
WEIGHT (@ALTITUDE) (LBS)	=	44914.60434
BETA (DEG)	=	0.03193
ALPHA (DEG)	=	2.66824
PHI (DEG)	=	70.62122
THETA (DEG)	=	0.91607
ALTITUDE RATE (FT/SEC)	=	0.00000
GAMMA (DEG)	=	0.00000
ROLL RATE (DEG/SEC)	=	-0.08951
PITCH RATE (DEG/SEC)	=	5.28086
YAW RATE (DEG/SEC)	=	1.85749
THRUST (LBS)	=	10277.03515
SUM OF THE SQUARES	=	0.00000

TRIM PARAMETERS

TRIM PITCH AXIS PARAMETER	=	-0.66958
TRIM ROLL AXIS PARAMETER	=	-0.01526
TRIM YAW AXIS PARAMETER	=	-0.02125
TRIM THRUST PARAMETER	=	0.21410

CONTROL VARIABLES

ELEVATOR	=	0.05380
THROTTLE	=	0.21410
SPEED BRAKE (DEG)	=	0.00000

OBSERVATION VARIABLES

AN	=	3.00163339	GS
AY	=	.94136286	GS

NON-DIMENSIONAL STABILITY AND CONTROL DERIVATIVES FOR CASE # 1  
 LINEARIZER TEST AND DEMONSTRATION CASES

FOR THE PROJECT:  
 USER'S GUIDE

	<u>ROLLING MOMENT</u>	<u>PITCHING MOMENT</u>	<u>YAWING MOMENT</u>	<u>DRAG</u>	<u>LIFT</u>	<u>SIDE FORCE</u>
ZERO COEFFICIENTS	-4.02966D-05	4.22040D-02	2.25747D-04	1.08760D-02	1.57360D-01	5.32725D-04
ROLL RATE (RAD/SEC)	-2.00000D-01	0.00000D+00	-3.37210D-02	0.00000D+00	0.00000D+00	0.00000D+00
PITCH RATE (RAD/SEC)	0.00000D+00	3.89530D+00	0.00000D+00	0.00000D+00	-1.72320D+01	0.00000D+00
YAW RATE (RAD/SEC)	1.50990D-01	0.00000D+00	-4.04710D-01	0.00000D+00	0.00000D+00	0.00000D+00
VELOCITY (FT/SEC)	-1.27955D-07	-3.28739D-06	3.21096D-07	0.00000D+00	1.45433D-05	0.00000D+00
MACH NUMBER	-1.32680D-04	-3.40878D-03	3.32952D-04	0.00000D+00	1.50803D-02	0.00000D+00
ALPHA (RAD)	0.00000D+00	-1.68820D-01	0.00000D+00	3.72570D-01	4.87060D+00	0.00000D+00
BETA (RAD)	-1.33450D-01	0.00000D+00	1.29960D-01	0.00000D+00	0.00000D+00	-9.74030D-01
ALTITUDE (FT)	0.00000D+00	0.00000D+00	0.00000D+00	0.00000D+00	0.00000D+00	0.00000D+00
ALPHA DOT (RAD/SEC)	0.00000D+00	-1.18870D+01	0.00000D+00	0.00000D+00	1.72320D+01	0.00000D+00
BETA DOT (RAD/SEC)	0.00000D+00	0.00000D+00	0.00000D+00	0.00000D+00	0.00000D+00	0.00000D+00
ELEVATOR	0.00000D+00	-6.95280D-01	0.00000D+00	4.38310D-02	5.72960D-01	0.00000D+00
THROTTLE	0.00000D+00	0.00000D+00	0.00000D+00	0.00000D+00	0.00000D+00	0.00000D+00
SPEED BRAKE	0.00000D+00	-4.17500D-01	0.00000D+00	6.49350D-02	3.74920D-02	0.00000D+00

VEHICLE STATIC MARGIN IS  
 AT THIS FLIGHT CONDITION.

3.5% MEAN AERODYNAMIC CHORD STABLE

MATRIX A USING THE FORMULATION OF THE STATE EQUATION:

$$DX / DT = A * X + B * U + D * V$$

FOR CASE # 1  
LINEARIZER TEST AND DEMONSTRATION CASES

FOR THE PROJECT:  
USER'S GUIDE

TIME DERIVATIVES WRT:	ALPHA	Q	THETA	VEL
ALPHA	-0.121436D+01	0.100000D+01	0.136756D-02	-0.121605D-03
Q	-0.147423D+01	-0.221451D+01	-0.450462D-02	0.294019D-03
THETA	0.000000D+00	0.331812D+00	0.000000D+00	0.000000D+00
VEL	-0.790853D+02	0.000000D+00	-0.320822D+02	-0.157297D-01

MATRIX B USING THE FORMULATION OF THE STATE EQUATION:

$$DX / DT = A * X + B * U + D * V$$

FOR CASE # 1  
LINEARIZER TEST AND DEMONSTRATION CASES

FOR THE PROJECT:  
USER'S GUIDE

TIME DERIVATIVES WRT:	ELEVATOR	THROTTLE	SPEED BRAKE
ALPHA	-0.141961D+00	-0.164948D-02	-0.928933D-02
Q	-0.220778D+02	0.543324D-02	-0.135074D+02
THETA	0.000000D+00	0.000000D+00	0.000000D+00
VEL	-0.105186D+02	0.342817D+02	-0.155832D+02

MATRIX D USING THE FORMULATION OF THE STATE EQUATION

$$DX / DT = A * X + B * U + D * V$$

FOR CASE # 1  
 LINEARIZER DEMONSTRATION AND TEST CASES

FOR THE PROJECT:  
 USER'S GUIDE

DERIVATIVES WRT	X-BODY AXIS FORCE	Y-BODY AXIS FORCE	Z-BODY AXIS FORCE	PITCHING MOMENT	ROLLING MOMENT
ALPHA	-0.343642D-07	0.000000D+00	0.737378D-06	0.000000D+00	0.000000D+00
Q	0.113192D-06	0.000000D+00	-0.242885D-05	0.605694D-05	0.000000D+00
THETA	0.000000D+00	0.000000D+00	0.000000D+00	0.000000D+00	0.000000D+00
VEL	0.714203D-03	0.398492D-06	0.332842D-04	0.000000D+00	0.000000D+00

DERIVATIVES  
 WRT

TIME OF:

DERIVATIVES WRT	YAWING MOMENT
ALPHA	0.000000D+00
Q	0.000000D+00
THETA	0.000000D+00
VEL	0.000000D+00

MATRIX H USING THE FORMULATION OF THE OBSERVATION EQUATION:

$$Y = H * X + F * U + E * V$$

FOR CASE # 1  
LINEARIZER TEST AND DEMONSTRATION CASES

FOR THE PROJECT:  
USER'S GUIDE

	ALPHA	Q	THETA	VEL
AN	0.351752D+02	0.277556D-16	0.150046D-02	0.640771D-02
AY	0.000000D+00	0.000000D+00	-0.150534D-01	0.446789D-10

MATRIX F USING THE FORMULATION OF THE OBSERVATION EQUATION:

$$Y = H * X + F * U + E * V$$

FOR CASE # 1  
LINEARIZER TEST AND DEMONSTRATION CASES

FOR THE PROJECT:  
USER'S GUIDE

	ELEVATOR	THROTTLE	SPEED BRAKE
AN	0.412845D+01	-0.180978D-02	0.291699D+00
AY	0.000000D+00	0.000000D+00	0.000000D+00

MATRIX E USING THE FORMULATION OF THE OBSERVATION EQUATION:

$$Y = H * X + F * U + E * V$$

FOR CASE # 1  
LINEARIZER DEMONSTRATION AND TEST CASES

FOR THE PROJECT:  
USER'S GUIDE

	X-BODY AXIS FORCE	Y-BODY AXIS FORCE	Z-BODY AXIS FORCE	PITCHING MOMENT	ROLLING MOMENT
AN	-0.377037D-07	0.000000D+00	-0.214132D-04	0.000000D+00	0.000000D+00
AY	0.000000D+00	0.222222D-04	0.000000D+00	0.000000D+00	0.000000D+00

YAWING MOMENT

AN	0.000000D+00
AY	0.000000D+00



TRIM CONDITIONS FOR CASE # 2  
LINEARIZER TEST AND DEMONSTRATION CASES

FOR THE PROJECT:  
USER'S GUIDE

STRAIGHT AND LEVEL TRIM WHILE VARYING ALPHA

TRIM ACHIEVED

COEFFICIENT OF LIFT	=	0.13221
COEFFICIENT OF DRAG	=	0.00895
LIFT (LBS)	=	44376.86258
DRAG (LBS)	=	3004.93778
ALTITUDE (FT)	=	20000.00000
MACH	=	0.90000
VELOCITY (FT/SEC)	=	933.23196
EQUIVALENT AIRSPEED (KTS)	=	403.42303
SPEED OF SOUND (FT/SEC)	=	1036.92440
GRAVITATIONAL ACCEL (FT/SEC**2)	=	32.11294
NORMAL ACCELERATION (G-S)	=	0.98523
LOAD FACTOR	=	0.98803
DYNAMIC PRESSURE (LB/FT**2)	=	552.05302
DENSITY (SLUG/FT**3)	=	0.00126774
WEIGHT (@ALTITUDE) (LBS)	=	44914.60434
BETA (DEG)	=	0.00000
ALPHA (DEG)	=	-0.72565
PHI (DEG)	=	0.00000
THETA (DEG)	=	9.27435
ALTITUDE RATE (FT/SEC)	=	162.05403
GAMMA (DEG)	=	10.00000
ROLL RATE (DEG/SEC)	=	0.00000
PITCH RATE (DEG/SEC)	=	0.00000
YAW RATE (DEG/SEC)	=	0.00000
THRUST (LBS)	=	10804.39673
SUM OF THE SQUARES	=	0.00000

TRIM PARAMETERS

TRIM PITCH AXIS PARAMETER	=	-0.79364
TRIM ROLL AXIS PARAMETER	=	0.00000
TRIM YAW AXIS PARAMETER	=	0.00000
TRIM THRUST PARAMETER	=	0.22509

CONTROL VARIABLES

ELEVATOR	=	0.06377
THROTTLE	=	0.22509
SPEED BRAKE	=	0.00000

OBSERVATION VARIABLES

AN	=	0.98522771	GS
AY	=	0.00000000	GS

NON-DIMENSIONAL STABILITY AND CONTROL DERIVATIVES FOR CASE #2  
 LINEARIZER TEST AND DEMONSTRATION CASES

FOR THE PROJECT:  
 USER'S GUIDE

	ROLLING MOMENT	PITCHING MOMENT	YAWING MOMENT	DRAG	LIFT	SIDE FORCE
ZERO COEFFICIENTS	1.25377D-16	4.22040D-02	1.22535D-16	1.08760D-02	1.57360D-01	4.15737D-16
ROLL RATE (RAD/SEC)	-2.00000D-01	0.00000D+00	-3.37210D-02	0.00000D+00	0.00000D+00	0.00000D+00
PITCH RATE (RAD/SEC)	0.00000D+00	3.89530D+00	0.00000D+00	0.00000D+00	-1.72320D+01	0.00000D+00
YAW RATE (RAD/SEC)	1.50990D-01	0.00000D+00	-4.04710D-01	0.00000D+00	0.00000D+00	0.00000D+00
VELOCITY (FT/SEC)	0.00000D+00	-6.48598D-10	0.00000D+00	0.00000D+00	9.40241D-10	0.00000D+00
MACH NUMBER	0.00000D+00	-6.72547D-07	0.00000D+00	0.00000D+00	9.74959D-07	0.00000D+00
ALPHA (RAD)	0.00000D+00	-1.68820D-01	0.00000D+00	3.72570D-01	4.87060D+00	0.00000D+00
BETA (RAD)	-1.33450D-01	0.00000D+00	1.29960D-01	0.00000D+00	0.00000D+00	-9.74030D-01
ALTITUDE (FT)	0.00000D+00	0.00000D+00	0.00000D+00	0.00000D+00	0.00000D+00	0.00000D+00
ALPHA DOT (RAD/SEC)	0.00000D+00	-1.18870D+01	0.00000D+00	0.00000D+00	1.72320D+01	0.00000D+00
BETADOT (RAD/SEC)	0.00000D+00	0.00000D+00	0.00000D+00	0.00000D+00	0.00000D+00	0.00000D+00
ELEVATOR	0.00000D+00	-6.95280D-01	0.00000D+00	4.38310D-02	5.72960D-01	0.00000D+00
THROTTLE	0.00000D+00	0.00000D+00	0.00000D+00	0.00000D+00	0.00000D+00	0.00000D+00
SPEED BRAKE	0.00000D+00	-4.17500D-01	0.00000D+00	6.49350D-02	3.74920D-02	0.00000D+00

VEHICLE STATIC MARGIN IS 3.5% MEAN AERODYNAMIC CHORD STABLE  
 AT THIS FLIGHT CONDITION.

MATRIX A USING THE FORMULATION OF THE STATE EQUATION:

$$DX / DT = A * X + B * U + D * V$$

FOR CASE # 2

LINEARIZER TEST AND DEMONSTRATION CASES

FOR THE PROJECT:

USER'S GUIDE

TIME DERIVATIVES WRT:	ALPHA	Q	THETA	VEL
ALPHA	-0.120900D+01	0.100000D+01	-0.575730D-02	-0.701975D-04
Q	-0.149189D+01	-0.221451D+01	0.189640D-01	0.231368D-03
THETA	0.000000D+00	0.100000D+01	0.000000D+00	0.000000D+00
VEL	-0.576868D+02	0.000000D+00	-0.316251D+02	-0.460435D-02

MATRIX B USING THE FORMULATION OF THE STATE EQUATION:

$$DX / DT = A * X + B * U + D * V$$

FOR CASE # 2

LINEARIZER TEST AND DEMONSTRATION CASES

FOR THE PROJECT:

USER'S GUIDE

TIME DERIVATIVES WRT:	ELEVATOR	THROTTLE	SPEED BRAKE
ALPHA	-0.141961D+00	0.448742D-03	-0.928932D-02
Q	-0.220778D+02	-0.147812D-02	-0.135074D+02
THETA	0.000000D+00	0.000000D+00	0.000000D+00
VEL	-0.105186D+02	0.343162D+02	-0.155832D+02

MATRIX D USING THE FORMULATION OF THE STATE EQUATION:

$$DX / DT = A * X + B * U + D * V$$

FOR CASE #2  
 LINEARIZER DEMONSTRATION AND TEST CASES

FOR THE PROJECT:  
 USER'S GUIDE

X-BODY AXIS FORCE Y-BODY AXIS FORCE Z-BODY AXIS FORCE PITCHING MOMENT ROLLING MOMENT

DERIVATIVES

WRT  
 TIME OF:

ALPHA	0.934880D-08	0.000000D+00	0.738119D-06	0.000000D+00	0.000000D+00
Q	-0.307941D-07	0.000000D+00	-0.243129D-05	0.605694D-05	0.000000D+00
THETA	0.000000D+00	0.000000D+00	0.000000D+00	0.000000D+00	0.000000D+00
VEL	0.714920D-03	0.000000D+00	-0.905497D-05	0.000000D+00	0.000000D+00

DERIVATIVES

WRT  
 TIME OF:

	YAWING MOMENT	
ALPHA	0.000000D+00	
Q	0.000000D+00	
THETA	0.000000D+00	
VEL	0.000000D+00	

MATRIX H USING THE FORMULATION OF THE OBSERVATION EQUATION:

$$Y = H * X + F * U + E * V$$

FOR CASE # 2  
LINEARIZER TEST AND DEMONSTRATION CASES

FOR THE PROJECT:  
USER'S GUIDE

	ALPHA	Q	THETA	VEL
AN	0.350424D+02	0.277556D-16	-0.632324D-02	0.203434D-02
AY	0.000000D+00	0.000000D+00	0.000000D+00	0.212306D-16

MATRIX F USING THE FORMULATION OF THE OBSERVATION EQUATION:

$$Y = H * X + F * U + E * V$$

FOR CASE # 2  
LINEARIZER TEST AND DEMONSTRATION CASES

FOR THE PROJECT:  
USER'S GUIDE

	ELEVATOR	THROTTLE	SPEED BRAKE
AN	0.411323D+01	0.492845D-03	0.263288D+00
AY	0.000000D+00	0.000000D+00	0.000000D+00

## MATRIX E USING THE FORMULATION OF THE OBSERVATION EQUATION:

$$Y = H * X + F * U + E * V$$

FOR CASE # 2  
LINEARIZER DEMONSTRATION AND TEST CASES

FOR THE PROJECT:  
USER'S GUIDE

	X-BODY AXIS FORCE	Y-BODY AXIS FORCE	Z-BODY AXIS FORCE	PITCHING MOMENT	ROLLING MOMENT
AN	0.102676D-07	0.000000D+00	-0.214116D-04	0.000000D+00	0.000000D+00
AY	0.000000D+00	0.222222D-04	0.000000D+00	0.000000D+00	0.000000D+00

YAWING MOMENT

AN	0.000000D+00
AY	0.000000D+00

---

---

TRIM CONDITIONS FOR CASE # 1  
LINEARIZER TEST AND DEMONSTRATION CASES

FOR THE PROJECT:  
USER'S GUIDE

LEVEL TURN WHILE VARYING ALPHA

TRIM ACHIEVED

COEFFICIENT OF LIFT	=	0.40144
COEFFICIENT OF DRAG	=	0.03058
LIFT (LBS)	=	134741.68807
DRAG (LBS)	=	10265.70661
ALTITUDE (FT)	=	20000.00000
MACH	=	0.90000
VELOCITY (FT/SEC)	=	933.23196
EQUIVALENT AIRSPEED (KTS)	=	403.42303
SPEED OF SOUND (FT/SEC)	=	1036.92440
GRAVITATIONAL ACCEL (FT/SEC**2)	=	32.11294
NORMAL ACCELERATION (G-S)	=	3.00163
LOAD FACTOR	=	2.99995
DYNAMIC PRESSURE (LBS/FT**2)	=	552.05302
DENSITY (SLUG/FT**3)	=	0.00126774
WEIGHT (@ALTITUDE) (LBS)	=	44914.60434
BETA (DEG)	=	0.03193
ALPHA (DEG)	=	2.66824
PHI (DEG)	=	70.62122
THETA (DEG)	=	0.91607
ALTITUDE RATE (FT/SEC)	=	0.00000
GAMMA (DEG)	=	0.00000
ROLL RATE (DEG/SEC)	=	-0.08951
PITCH RATE (DEG/SEC)	=	5.28086
YAW RATE (DEG/SEC)	=	1.85749
THRUST (LBS)	=	10277.03515
SUM OF THE SQUARES	=	0.00000



TRIM PARAMETERS

TRIM PITCH AXIS PARAMETER	=	-0.66958
TRIM ROLL AXIS PARAMETER	=	-0.01526
TRIM YAW AXIS PARAMETER	=	-0.02125
TRIM THRUST PARAMETER	=	0.21410

CONTROL VARIABLES

ELEVATOR	=	0.05380
THROTTLE	=	0.21410
SPEED BRAKE (DEG)	=	0.00000

OBSERVATION VARIABLES

AN	=	3.00163339	GS
AY	=	.94136286	GS

VEHICLE STATIC MARGIN IS 3.5% MEAN AERODYNAMIC CHORD STABLE AT THIS FLIGHT CONDITION

TRIM CONDITIONS FOR CASE # 2  
LINEARIZER TEST AND DEMONSTRATION CASES

FOR THE PROJECT:  
USER'S GUIDE

STRAIGHT AND LEVEL TRIM WHILE VARYING ALPHA

TRIM ACHIEVED

COEFFICIENT OF LIFT	=	0.13221
COEFFICIENT OF DRAG	=	0.00895
LIFT (LBS)	=	44376.86258
DRAG (LBS)	=	3004.93778
ALTITUDE (FT)	=	20000.00000
MACH	=	0.90000
VELOCITY (FT/SEC)	=	933.23196
EQUIVALENT AIRSPEED (KTS)	=	403.42303
SPEED OF SOUND (FT/SEC)	=	1036.92440
GRAVITATIONAL ACCEL (FT/SEC**2)	=	32.11294
NORMAL ACCELERATION (G-S)	=	0.98523
LOAD FACTOR	=	0.98803
DYNAMIC PRESSURE (LB/FT**2)	=	552.05302
DENSITY (SLUG/FT**3)	=	0.00126774
WEIGHT (@ALTITUDE) (LBS)	=	44914.60434
BETA (DEG)	=	0.00000
ALPHA (DEG)	=	-0.72565
PHI (DEG)	=	0.00000
THETA (DEG)	=	9.27435
ALTITUDE RATE (FT/SEC)	=	162.05403
GAMMA (DEG)	=	10.00000
ROLL RATE (DEG/SEC)	=	0.00000
PITCH RATE (DEG/SEC)	=	0.00000
YAW RATE (DEG/SEC)	=	0.00000
THRUST (LBS)	=	10804.39673
SUM OF THE SQUARES	=	0.00000

TRIM PARAMETERS

TRIM PITCH AXIS PARAMETER	=	-0.79364
TRIM ROLL AXIS PARAMETER	=	0.00000
TRIM YAW AXIS PARAMETER	=	0.00000
TRIM THRUST PARAMETER	=	0.22509

CONTROL VARIABLES

ELEVATOR	=	0.06377
THROTTLE	=	0.22509
SPEED BRAKE	=	0.00000

OBSERVATION VARIABLES

AN	=	0.98522771	GS
AY	=	0.00000000	GS

VEHICLE STATIC MARGIN IS 3.5% MEAN AERODYNAMIC CHORD STABLE AT THIS FLIGHT CONDITION.

---

## APPENDIX J: EXAMPLE USER-SUPPLIED SUBROUTINES

The following subroutines are examples of the user-supplied routines that provide the aerodynamic, control, engine, and mass and geometry models to LINEAR. These subroutines are based on an F-15 simulation and are typical of the routines needed to interface LINEAR to a set of nonlinear simulation models. These subroutines are meant to show the use of the named common blocks to communicate between LINEAR and the user's routines. These subroutines are used with all examples in this report. Included with this report are microfiche listings of these subroutines.

### Aerodynamic Model Subroutines

The following two subroutines define a linear aerodynamic model. Even though this model is greatly simplified from the typical nonlinear aerodynamic model, the example shows the functions of the subroutines ADATIN and CCALC.

#### SUBROUTINE ADATIN

```

C
C.... EXAMPLE AERODYNAMIC DATA DEFINITION (OR INPUT) SUBROUTINE
C
C.... ROUTINE TO DEFINE STABILITY AND CONTROL DERIVATIVES FOR THE
C      AERODYNAMIC MODEL
C
C
C      COMMON BLOCK TO COMMUNICATE AERODYNAMIC DATA BETWEEN THE
C      SUBROUTINES ADATIN AND CCALC
C
C
COMMON /ARODAT/ CLB      ,CLP      ,CLR      ,
.      CLDA ,CLDR ,CLDT ,
.      CMO  ,CMA  ,CMQ  ,CMAD  ,
.      CMDE ,CMSB ,
.      CNB  ,CNP  ,CNR  ,
.      CNDA ,CNDR ,CNDT ,
.      CDO  ,CDA  ,CDDE ,CDSB  ,
.      CLFTO ,CLFTA ,CLFTQ ,CLFTAD ,
.      CLFTDE,CLFTSB,
.      CYB  ,CYDA ,CYDR  ,CYDT
C
C.... ROLLING MOMENT DERIVATIVES.
C
C      STABILITY DERIVATIVES WITH RESPECT TO
C      SIDESLIP, ROLL RATE, YAW RATE . . .
C
CLB  = -1.3345 D-01
CLP  = -2.0000 D-01
CLR  =  1.5099 D-01
C
C      CONTROL DERIVATIVES WITH RESPECT TO
C      AILERON, RUDDER, DIFFERENTIAL TAIL . . .
C

```

CLDA = 2.6356 D-02  
CLDR = -2.3859 D-03  
CLDT = 4.0107 D-02

C

C.... PITCHING MOMENT DERIVATIVES.

C

C STABILITY DERIVATIVES WITH RESPECT TO ANGLE OF  
C ATTACK, PITCH RATE, ANGLE OF ATTACK RATE . . .

C

CMO = 4.2204 D-02

C

CMA = -1.6882 D-01

CMQ = 3.8953

CMAD = -1.1887 D+01

C

C CONTROL DERIVATIVES WITH RESPECT TO  
C ELEVATOR, SPEED BRAKE . . .

C

CMDE = -6.9528 D-01

CMSB = -4.1750 D-01

C

C.... YAWING MOMENT DERIVATIVES.

C

C STABILITY DERIVATIVES WITH RESPECT TO  
C SIDESLIP, ROLL RATE, YAW RATE . . .

C

CNB = 1.2996 D-01

CNP = -3.3721 D-02

CNR = -4.0471 D-01

C

C CONTROL DERIVATIVES WITH RESPECT TO  
C AILERON, RUDDER, DIFFERENTIAL TAIL . . .

C

CNDA = 2.1917 D-03

CNDR = -6.9763 D-02

CNDT = 3.0531 D-02

C

C.... COEFFICIENT OF DRAG DERIVATIVES.

C

C STABILITY DERIVATIVES WITH RESPECT TO  
C ANGLE OF ATTACK . . .

C

CDO = 1.0876 D-02

C

CDA = 3.7257 D-01

C

C CONTROL DERIVATIVES WITH RESPECT TO  
C ELEVATOR, SPEED BRAKE . . .

C

CDDE = 4.3831 D-02

CDSB = 6.4935 D-02

C

```

C.... COEFFICIENT OF LIFT DERIVATIVES.
C
C      STABILITY DERIVATIVES WITH RESPECT TO ANGLE OF
C      ATTACK, PITCH RATE, ANGLE OF ATTACK RATE . . .
C
CLFTO = 1.5736 D-01
C
CLFTA = 4.8706
CLFTQ = -1.7232 D+01
CLFTAD= 1.7232 D+01
C
C      CONTROL DERIVATIVES WITH RESPECT TO
C      ELEVATOR, SPEED BRAKE . . .
C
CLFTDE= 5.7296 D-01
CLFTSB= 3.7492 D-02
C
C.... SIDEFORCE COEFFICIENT DERIVATIVES.
C
C      STABILITY DERIVATIVES WITH RESPECT TO
C      SIDESLIP . . .
C
CYB   = -9.7403 D-01
C
C      CONTROL DERIVATIVES WITH RESPECT TO
C      AILERON, RUDDER, DIFFENTIAL TAIL
C
CYDA  = -1.1516 D-03
CYDR  = -1.5041 D-01
CYDT  = -7.9315 D-02
C
RETURN
END

SUBROUTINE CCALC
C
C.... EXAMPLE AERODYNAMIC MODEL.
C
C.... ROUTINE TO CALCULATE THE AERODYNAMIC FORCE AND MOMENT COEFFICIENTS.
C
C      COMMON BLOCKS CONTAINING STATE, CONTROL, AND AIR
C      DATA PARAMETERS
C
COMMON /DRVOUT/ F(13),DF(13)
COMMON /CONTRL/ DC(30)
C
COMMON /DATAIN/ S,B,CBAR,AMSS,AIX,AIY,AIZ,AIXZ,AIXY,AIYZ,AIXE
COMMON /TRIGN/  SINALP,COSALP,SINBTA,COSBTA,SINPHI,COSPHI,
.              SINPSI,COSPSI,SINTHA,COSTHA
COMMON /SIMOUT/ AMCH,QBAR,GMA,DEL,UB,VB,WB,VEAS,VCAS
COMMON /CGSHFT/ DELX,DELY,DELZ
C

```

C COMMON BLOCK TO OUTPUT AERODYNAMIC FORCE AND MOMENT  
 C COEFFICIENTS

C COMMON /CLCOUT/ CL ,CM ,CN ,CD ,CLFT ,CY

C COMMON BLOCK TO COMMUNICATE AERODYNAMIC DATA BETWEEN  
 C THE SUBROUTINES ADATIN AND CCALC

C COMMON /ARODAT/ CLB ,CLP ,CLR ,  
 . CLDA ,CLDR ,CLDT ,  
 . CMO ,CMA ,CMQ ,CMAD ,  
 . CMDE ,CMSB ,  
 . CNB ,CNP ,CNR ,  
 . CNDA ,CNDR ,CNDT ,  
 . CDO ,CDA ,CDDE ,CDSB ,  
 . CLFTO ,CLFTA ,CLFTQ ,CLFTAD ,  
 . CLFTDE,CLFTSB ,  
 . CYB ,CYDA ,CYDR ,CYDT

C EQUIVALENCE VARIABLE NAMES

C EQUIVALENCE (T , F( 1)),  
 . (P , F( 2)),(Q , F( 3)),(R , F( 4)),  
 . (V , F( 5)),(ALP , F( 6)),(BTA , F( 7)),  
 . (THA , F( 8)),(PSI , F( 9)),(PHI , F(10)),  
 . (H , F(11)),(X , F(12)),(Y , F(13)),  
 . (TDOT ,DF( 1)),  
 . (PDOT ,DF( 2)),(QDOT ,DF( 3)),(RDOT ,DF( 4)),  
 . (VDOT ,DF( 5)),(ALPDOT,DF( 6)),(BTADOT,DF( 7)),  
 . (THADOT ,DF( 8)),(PSIDOT,DF( 9)),(PHIDOT,DF(10)),  
 . (HDOT ,DF(11)),(XDOT ,DF(12)),(YDOT ,DF(13))

C EQUIVALENCE (DA ,DC( 1)),(DE ,DC( 5)),(DT ,DC( 8)),  
 . (DR ,DC( 9)),(DSB ,DC(10))

C C.... COMPUTE TERMS NEEDED WITH ROTATIONAL DERIVATIVES.

C V2 = 2.0 \*V  
 B2V =B /V2  
 C2V =CBAR /V2

C C.... ROLLING MOMENT COEFFICIENT.

C CL =CLB \* BTA +CLDA \*DA +CLDR \*DR +CLDT \*DT  
 . +B2V \*(CLP \*P +CLR \*R )

C C.... PITCHING MOMENT COEFFICIENT.

C CM =CMO + CMA \*ALP +CMDE \*DE +CMSB \*DSB  
 . +C2V \*(CMQ \*Q +CMAD \*ALPDOT)

C C.... YAWING MOMENT COEFFICIENT.

C

```

      CN  =CNB      * BTA   +CNDA   *DA   +CNDR   *DR   +CNDT   *DT
      .   +B2V     *(CNP   *P     +CNR   *R   )
C
C.... COEFFICIENT OF DRAG.
C
      CD  =CDO     + CDA   *ALP   +CDDE  *DE   +CDSB  *DSB
C
C.... COEFFICIENT OF LIFT.
C
      CLFT =CLFTO  + CLFTA  *ALP   +CLFTDE*DE   +CLFTSB*DSB
      .   +C2V     *(CLFTQ  *Q     +CLFTAD*ALPDOT )
C
C.... SIDEFORCE COEFFICIENT.
C
      CY  =CYB     *BTA   +CYDA   *DA   +CYDR   *DR   +CYDT   *DT
C
      RETURN
      END

```

Control Model Subroutine

The following subroutine UCNTL models the gearing between the control inputs (that is, trim parameters  $\delta_a$ ,  $\delta_e$ ,  $\delta_r$ , and thr) and the control surfaces. This provides LINEAR with a generic interface capable of handling most airborne vehicles. Figure 8 shows the control system implemented in this example subroutine UCNTL.

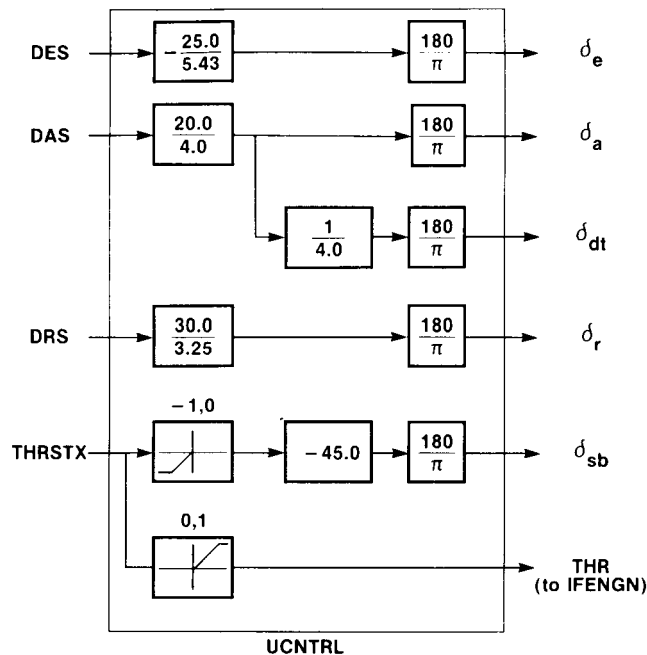

Figure 8. Gearing model in example UCNTL subroutine.



SUBROUTINE UCNTRL

```

C
C.... EXAMPLE TRIM/CONTROL SURFACE INTERFACE ROUTINE.
C
C.... ROUTINE TO CONVERT TRIM INPUTS INTO CONTROL SURFACE DEFLECTIONS.
C
C
C      INPUT COMMON BLOCK CONTAINING TRIM PARAMETERS
C
COMMON /CTPARAM/ DES ,DAS ,DRS ,THRSTX
C
C      OUTPUT COMMON BLOCK CONTAINING CONTROL SURFACE DEFLECTIONS.
C
COMMON /CONTRL/ DC(30)
C
C      EQUIVALENCE VARIABLE NAMES.
C
EQUIVALENCE (DA ,DC( 1)),(DE ,DC( 5)),(DT ,DC(8)),
.          (DR ,DC( 9)),(DSB ,DC(10)),(THR ,DC(12))
C
DATA DGR /57.29578/
C
C.... CONVERT FROM INCHES OF STICK AND PEDAL TO DEGREES OF SURFACE.
C
DA =DAS *( 20.0 / 4.0 )
DE =DES *(-25.0 / 5.43)
DR =DRS *( 30.0 / 3.25)
C
C.... SET DIFFERENTIAL TAIL BASED ON AILERON COMMAND.
C
DT =DA / 4.0
C
C.... CONVERT THRUST TRIM PARAMETER TO PERCENT THROTTLE COMMAND.
C
THR = 0.0
IF(THRSTX.GE. 0.0 ) THR =THRSTX
C
C.... USE SPEED BRAKE IF NEEDED.
C
DSB = 0.0
IF(THRSTX.LT. 0.0 ) DSB =THRSTX*(-45.0 )
C
C.... CONVERT SURFACE COMMANDS TO RADIANS.
C
DA =DA /DGR
DE =DE /DGR
DR =DR /DGR
DT =DT /DGR
DSB =DSB /DGR
C
RETURN
END

```

## Engine Model Interface Subroutine

The following subroutine IFENGN both defines an engine model and provides the interface to LINEAR. In normal usage, this subroutine would call subroutines that do the detailed thrust, engine rotation, and fuel consumption modeling; the information from these subroutines would be transferred into the /ENGSTF/ common block.

```

SUBROUTINE IFENGN
C
C.... EXAMPLE SUBROUTINE TO PROVIDE PROPULSION SYSTEM MODEL.
C
C.... ROUTINE TO COMPUTE PROPULSION SYSTEM INFORMATION FOR LINEAR
C
C THIS SUBROUTINE IS THE INTERFACE BETWEEN THE DETAILED ENGINE
C MODELING SUBROUTINES AND LINEAR.
C
C     INPUT COMMON BLOCK CONTAINING INFORMATION ON THRUST
C     REQUEST TO ENGINE
C
C     COMMON /CONTRL/ DC(30)
C
C     OUTPUT COMMON BLOCK CONTAINING DETAILED INFORMATION
C     ON EACH OF UP TO FOUR SEPARATE ENGINES
C
C.... ROUTINE TO COMPUTE ENGINE PARAMETERS:
C
C     THRUST(I) = THRUST CREATED BY EACH ENGINE
C     TLOCAT(I,J) = LOCATION OF EACH ENGINE IN THE X-Y-Z PLANE
C     XYANGL(I) = ANGLE IN X-Y BODY AXIS PLANE AT WHICH EACH
C     ENGINE IS MOUNTED
C     XZANGL(I) = ANGLE IN X-Z BODY AXIS PLANE AT WHICH EACH
C     ENGINE IS MOUNTED
C     TVANXY(I) = ANGLE IN THE X-Y ENGINE AXIS PLANE OF THE
C     THRUST VECTOR
C     TVANXZ(I) = ANGLE IN THE X-Z ENGINE AXIS PLANE OF THE
C     THRUST VECTOR
C     DXTHRS(I) = DISTANCE BETWEEN THE ENGINE C.G. AND THE
C     THRUST POINT
C     EIX(I) = ROTATIONAL INERTIA OF EACH ENGINE
C     AMSENG(I) = MASS OF EACH ENGINE
C     ENGOMG(I) = ROTATIONAL VELOCITY (RAD/SEC)
C
C     COMMON /ENGSTF/ THRUST(4),TLOCAT(4,3),XYANGL(4),XZANGL(4),
C     .             TVANXY(4),TVANXZ(4),DXTHRS(4),
C     .             EIX(4),AMSENG( 4),ENGOMG(4)
C
```

```

C           EQUIVALENCE VARIABLE NAMES
C
C           EQUIVALENCE (THR      ,DC(12))
C
C.... ASSUME THRUST PER ENGINE IS HALF VEHICLE WEIGHT.
C
C           THRUST(1)= 24000.0 *THR
C           THRUST(2)= 24000.0 *THR
C
C.... LET ALL OTHER PARAMETERS DEFAULT TO ZERO
C
C           RETURN
C           END

```

### Mass and Geometry Model

The subroutine MASGEO enables the user to model mass, inertia, and center-of-gravity changes due to vehicle configuration or mass changes. This particular version is simply a RETURN and END statement, because the aircraft that it models is a fixed-wing vehicle, and any mass changes can be done through the input files or even interactively. However, this subroutine does provide an elegant way of including a model of those changes for other aircraft.

#### SUBROUTINE MASGEO

```

C
C.... SUBROUTINE TO COMPUTE THE MASS AND GEOMETRY PROPERTIES OF THE
C AIRCRAFT.
C
C           COMMON /CONPOS/ DAP,FLAT,DATRIM,DEP,FLON,DETRIM,DRP,FPRF,DRTRIM,
C           .           DSBP,DFP,PLAPL,PLAPR,THSL,THSR
C           COMMON /CONTRL/ DC(30)
C           COMMON /DATAIN/ S,B,CBAR,AMSS,AIX,AIY,AIZ,AIXZ,AIXY,AIYZ,AIXE
C           COMMON /SIMOUT/ AMCH,QBAR,GMA,DEL,UB,VB,WB,VEAS,VCAS
C           COMMON /DRVOUT/ F(13),DF(13)
C           EQUIVALENCE (T      , F( 1)),
C           .           (P      , F( 2)),(Q      , F( 3)),(R      , F( 4)),
C           .           (V      , F( 5)),(ALP    , F( 6)),(BTA    , F( 7)),
C           .           (THA    , F( 8)),(PSI    , F( 9)),(PHI    , F(10)),
C           .           (H      , F(11)),(X      , F(12)),(Y      , F(13)),
C           .           (TDOT   ,DF( 1)),
C           .           (PDOT   ,DF( 2)),(QDOT   ,DF( 3)),(RDOT   ,DF( 4)),
C           .           (VDOT   ,DF( 5)),(ALPDOT,DF( 6)),(BTADOT,DF( 7)),
C           .           (THADOT,DF( 8)),(PSIDOT,DF( 9)),(PHIDOT,DF(10)),
C           .           (HDOT   ,DF(11)),(XDOT   ,DF(12)),(YDOT   ,DF(13))
C
C           RETURN
C           END

```

## REFERENCES

- Chen, R.T.N.: Kinematic Properties of Rotary-Wing and Fixed-Wing Aircraft in Steady Coordinated High-g Turns. AIAA-81-1855, Aug. 1981.
- Chen, R.T.N.; and Jeske, J.A.: Kinematic Properties of the Helicopter in Coordinated Turns. NASA TP-1773, 1981.
- Clancy, L.J.: Aerodynamics. John Wiley & Sons, New York, 1975.
- Dieudonne, J.E.: Description of a Computer Program and Numerical Techniques for Developing Linear Perturbation Models From Nonlinear Systems Simulations. NASA TM-78710, 1978.
- Dommasch, D.O.; Sherby, S.S.; and Connolly, T.F.: Airplane Aerodynamics, Fourth edition. Pitman Publishing Company, New York, 1967.
- Duke, E.L.; Antoniewicz, R.F.; and Krambeer, K.D.: Derivation and Definition of a Linear Aircraft Model. NASA RP-1207, 1988.
- Duke, E.L.; Patterson, B.P.; and Antoniewicz, R.F.: User's Manual for LINEAR, a FORTRAN Program to Derive Linear Aircraft Models. NASA TP-2768, 1987.
- Etkin, Bernard: Dynamics of Atmospheric Flight. John Wiley & Sons, New York, 1972.
- Gainer, T.G.; and Hoffman, Sherwood: Summary of Transformation Equations and Equations of Motion Used in Free-Flight and Wind-Tunnel Data Reduction and Analysis. NASA SP-3070, 1972.
- Gracey, William: Measurement of Aircraft Speed and Altitude. NASA RP-1046, 1980.
- Kalviste, Juri: Fixed Point Analysis Program. NOR 80-165, Northrop Corporation, Aircraft Division, Hawthorne, California, Nov. 1980.
- Kwakernaak, Huibert; and Sivan, Raphael: Linear Optimal Control Systems. Wiley Interscience, New York, 1972.
- Perkins, C.D.; and Hage, R.E.: Airplane Performance Stability and Control. John Wiley & Sons, New York, 1949.
- Thelander, J.A.: Aircraft Motion Analysis. Air Force Flight Dynamics Laboratory, FDL-TDR-64-70, Mar. 1965.
- U.S. Standard Atmosphere, 1962. U.S. Government Printing Office, 1962.





# Report Documentation Page

1. Report No. NASA TP-2835		2. Government Accession No.		3. Recipient's Catalog No.	
4. Title and Subtitle  User's Manual for Interactive LINEAR, a FORTRAN Program To Derive Linear Aircraft Models				5. Report Date September 1988	
				6. Performing Organization Code H-1443	
7. Author(s)  Robert F. Antoniewicz, Eugene L. Duke, and Brian P. Patterson				8. Performing Organization Report No. RTOP 505-66-11	
				10. Work Unit No.	
9. Performing Organization Name and Address  NASA Ames Research Center Dryden Flight Research Facility P.O. Box 273, Edwards, CA 93523-5000				11. Contract or Grant No.	
				13. Type of Report and Period Covered Technical Paper	
12. Sponsoring Agency Name and Address  National Aeronautics and Space Administration Washington, DC 20546				14. Sponsoring Agency Code	
15. Supplementary Notes  A listing of the program Interactive LINEAR is provided in the microfiche supplement included with this report (4 sheets total).					
16. Abstract  An interactive FORTRAN program that provides the user with a powerful and flexible tool for the linearization of aircraft aerodynamic models is documented in this report. The program LINEAR numerically determines a linear system model using nonlinear equations of motion and a user-supplied linear or nonlinear aerodynamic model. The nonlinear equations of motion used are six-degree-of-freedom equations with stationary atmosphere and flat, nonrotating earth assumptions. The system model determined by LINEAR consists of matrices for both the state and observation equations. The program has been designed to allow easy selection and definition of the state, control, and observation variables to be used in a particular model.					
17. Key Words (Suggested by Author(s)) Aircraft model Computer program Control law design Linearization			18. Distribution Statement Unclassified - Unlimited  Subject category 66		
19. Security Classif. (of this report) Unclassified		20. Security Classif. (of this page) Unclassified		21. No. of pages 124	22. Price A06