

Space Science and Engineering Center  
University of Wisconsin-Madison

HIGH-RESOLUTION INTERFEROMETER SOUNDER (HIS) PHASE II

**NASA CR-** 183414

# A REPORT from the

Cooperative  
Institute for  
Meteorological  
Satellite  
Studies

(NASA-CR-183414) HIGH-RESOLUTION  
INTERFEROMETER SOUNDER (HIS), PHASE 2 Final  
Report (Wisconsin Univ.) 35 p CSCI 14B

N89-17212

G3/35 Unclas  
0191652

ORIGINAL PAGE IS  
OF POOR QUALITY

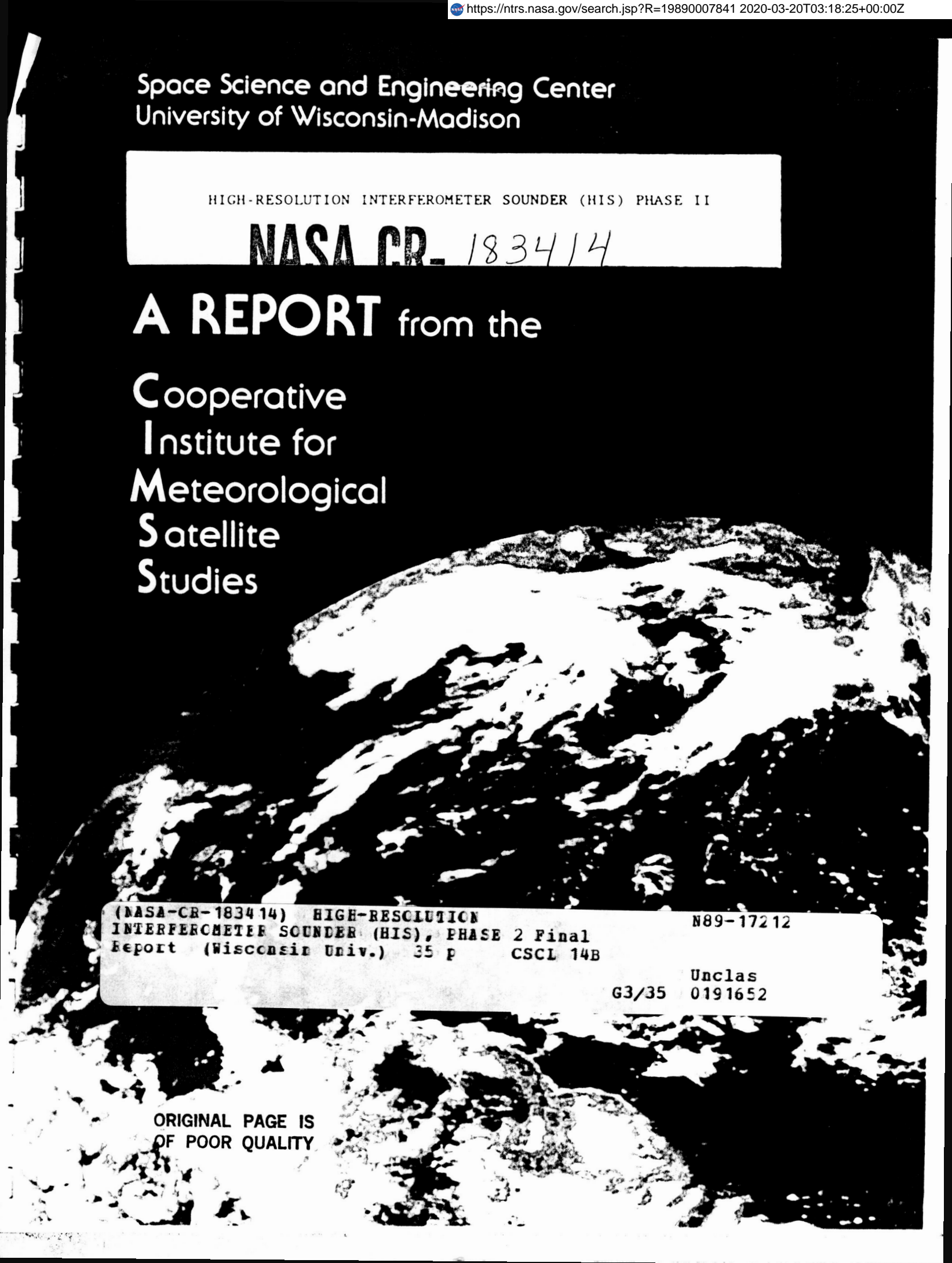

HIGH-RESOLUTION INTERFEROMETER SOUNDER (HIS) PHASE II

Final Report of Contract NAS5-27608

Submitted to

National Aeronautics and Space Administration  
Goddard Space Flight Center  
Greenbelt, Maryland

from

Cooperative Institute for Meteorological Satellite Studies (CIMSS)  
Space Science and Engineering Center (SSEC)  
University of Wisconsin-Madison  
1225 West Dayton Street  
Madison, Wisconsin 53706  
(608) 262-0544

October 1988

TABLE OF CONTENTS

1. Introduction.....1  
2. Design and Fabrication.....1  
3. Flight Testing.....2  
4. Primary Data Collection Flights.....3  
5. Radiometric Performance.....4  
6. Sounding Retrieval Results.....4  
7. Reference Papers and Conference Presentations.....4

ATTACHMENTS: Seven Reference Papers (Ref 1. - Ref 7.)

HIGH-RESOLUTION INTERFEROMETER SOUNDER (HIS) PHASE II

1. Introduction

This is the final report for contract NAS5-27608 under which the High-resolution Interferometer Sounder (HIS) aircraft instrument was successfully built, tested, and flight proven on the NASA U-2/ER-2 high altitude aircraft. The contract extended over nearly four years; from 13 May 1983, when the detailed design phase began, to 31 March 1987, at which time the instrument had flown in several very successful field expeditions.

The HIS aircraft demonstration (Phase II) has shown that, by using the technology of Fourier Transform Spectroscopy (FTS), it is possible to measure the spectrum of upwelling infrared radiance needed for temperature and humidity sounding (3.7 to 16.7  $\mu\text{m}$ ) with high spectral resolution ( $\lambda/\Delta\lambda > 2000$ ) and high radiometric precision ( $< 0.1^\circ\text{C}$  RMS noise equivalent temperature). By resolving individual carbon dioxide lines, the retrieved temperature profiles have vertical resolutions of 1-2 km and RMS errors  $< 1^\circ\text{C}$ , about 2 to 4 times better than possible with current sounders. Implementing this capability on satellite sounders will greatly enhance the dynamical information content of temperature measurements from space.

The aircraft model HIS is now a resource which should be used to support field experiments in mesoscale meteorology, to monitor trace gas concentrations and to better understand their effects on climate, to monitor the surface radiation budget and the radiative effects of clouds, and to collect data for research into retrieval techniques, especially under partially cloudy conditions.

2. Design and Fabrication

The aircraft instrument was built at the University of Wisconsin-Madison Space Science and Engineering Center (SSEC) with the key participation of three subcontractors. The auto-aligned interferometer designed for field applications and its associated control and post-processing electronics were provided by BOMEM, Inc of Quebec, Canada. The complete optical design, including detailed definition of the input telescope, collimator, relay and condensor optics, and band pass filters, was performed by the Santa Barbara Research Center (SBRC), who also provided predicted performance calculations. The onboard recording system hardware and software was provided by the University of Denver. In addition, the subcontractors all provided overall guidance on design and field operations, based on their substantial experience with FTS systems.

Three design reviews were held in rapid succession as soon as all subcontracts were in place. The first occurred on 29-30 September 1983 at BOMEM, the second on 6-7 December 1983 at SSEC and the final



design was presented at the Critical Design Review (CDR) on 21 February 1984 at SBRC.

The fabrication and assembly at SSEC was completed early in May 1985, just over one year after CDR. During this time two smaller, but important, subcontracts were completed, one with SBRC for the arsenic-doped-silicon detectors used in all of the three separate spectral bands and one with Eppley Laboratories for the reference blackbodies used to establish absolute onboard calibration. An important part of the assembly procedure was the optical alignment of the elements on the optics bench and inside the dewar/detector assembly. Careful alignment is required to assure the accuracy of the onboard calibration.

The instrument, one of its aircraft mounting configurations, and its most critical components are illustrated with photographs in Figures 1-6. In addition to the ER-2 underbelly mount shown, the instrument was also flown in the same pod, mounted under the wing of both the U-2 and the ER-2. More specific information on the characteristics of the instrument is given in the attached references 1 and 2.

### 3. Flight Testing

Immediately following the completion of fabrication, a series of test flights were conducted. These flights were undertaken even before detailed ground testing was completed, so that any basic problems related to the aircraft configuration and the inflight thermal and humidity environment could be detected at an early stage. Data were collected during six flights over several target areas including clear ocean (14 May), the special Earth Radiation Budget Experiment verification site near Yuma Arizona (15, 17, and 18 May), and over the Pre-Storm network in Kansas (18, 20, and 23 May). These tests were extremely successful at demonstrating the functional integrity of the instrument design. All of the instrument subsystems functioned on the first flight. Some problems were encountered with the data system, with the dissipation of heat from the power supplies, and with large noise levels, but the basic design approach was proven to be free of fundamental flaws.

Following instrument modifications, which reduced noise level to photon limited performance in the lab, and end-to-end ground testing, which demonstrated the success of the onboard calibration approach, a second series consisting of five flights were conducted from NASA Ames in August. These flights showed that the photon limited performance observed on the ground could be realized in flight. Channels I and II covering 600 to 1800  $\text{cm}^{-1}$  showed no evidence of additional noise sources. Channel III covering 2100 to 2600  $\text{cm}^{-1}$  did pickup an additional noise source, especially noticeable at large wavenumbers (peaking beyond 2500  $\text{cm}^{-1}$ ). Extra filtering later improved this noise problem, but it still has not been completely eliminated (see reference 1).

Analyses conducted on-site at Ames concluded that the instrument performance was unmarred by major problems and the calibrated spectra compared reasonably well with calculated spectra. Unfortunately, upon closer inspection, we found evidence of a problem, which placed significant limitations on the useful spectral resolution of the data collected during these flights. The problem created subtle errors in the interferograms that were not easily seen. The 15 micron CO<sub>2</sub> resonances were very close to the right shapes and were in nearly the right locations. However the effect on the full resolution spectra was large compared to the 0.1% accuracy goal of HIS (variability of spectra from one scan to the next by a few percent). As reported in the program review held at SSEC on 11-12 December 1985, the problem was traced to the loss of a small percentage of laser-fringe-rate samples, which occurred because the electronics timing margin was inadequate to allow error free operation under the flight vibration environment.

Fortunately, this problem and other smaller ones were solved by the time of the next flight series in 1986.

#### 4. Primary Data Collection Flights

The HIS aircraft instrument was flown on dozens of flights over many different atmospheric conditions in 1986. It turned out to be a very reliable aircraft instrument, with over 90% of the flight time yielding high quality data.

Flights resumed on 14 April with a very good test flight over the Pacific Ocean from NASA Ames on the U-2. On 15-17 April, daily flights were made over the Kitt Peak observatory in Arizona. The objective was a to determine the atmospheric transmittance (by measuring the solar absorption spectrum as a function of air mass) from the observatory for the same air mass for which emission measurements were made from the aircraft HIS. This is not an easy task considering all of the potential difficulties with the weather, the instrumentation on the plane and at Kitt Peak, and the aircraft itself. We did succeed on one of three possible days. Simultaneous absorption measurements were made with Brault's interferometer on the McMath Solar Telescope [5] on 15 April. The wind on the mountain closed the telescope on 16 April, and on 17 April the HIS suffered one of its few failures, when the scene switching mirror failed in the hot blackbody position. This data set has recently been the source of a Master's thesis by Arlindo Arriaga, under the direction of Professor W.L. Smith.

In June and July, the HIS instrument was flown in support of the NASA COmbined Huntsville Meteorological EXperiment (COHMEX), an intensive study of convective storms and their precursor conditions, conducted near NASA Marshall. Twenty flights were conducted from the airbase at Wallops Island, Virginia. The HIS was flown both under the wing of the U-2, as in all previous flights, and in a new

configuration on the underbelly of the ER-2 (see Figures 2 and 3). Although there was some variation of the quality of the data with aircraft and with the various small configurational changes tried in attempting to minimize vibration effects, good data was collected from every one of the flights.

In October and November, 10 flights were made in support of the NASA FIRE experiment in Wisconsin to study the radiative impact of cirrus clouds. The HIS was flown exclusively on the ER-2 underbelly. With the exception of one problem when a small chip of glass lodged in the Michelson mirror drive, the FIRE data was of high quality. However, as mentioned in attached reference 1, sample position errors are somewhat larger in the underbelly mounting position on the ER-2 than in the underwing mounting position on either the U-2 or the ER-2.

#### 5. Radiometric Performance

The calibration accuracy and noise performance are described in detail in the attached references 1-3. In brief, the high radiometric requirements needed for sounding retrievals were realized. Thereby, it has been demonstrated for the first time with direct measurements that the interferometric approach is especially well suited to provide the radiometrically precise, high spectral resolution sounding measurements needed to improve the quality of passive sounding retrievals.

#### 6. Sounding Retrieval Results

Retrieval procedures and results are presented in references 4-7. In summary, the HIS measurements have demonstrated the meteorologically important increase in vertical resolution which can be realized from high spectral resolution measurements.

#### 7. Reference Papers and Conference Presentations

The results of this contract have been presented in numerous papers and presentations. The following papers which are referenced to provide detailed support for this report are included as attachments:

- Ref 1. "High-Altitude Aircraft Measurements of Upwelling IR Radiance: Prelude to FTIR from Geosynchronous Satellite", H.E. Revercomb, D.D. LaPorte, W.L. Smith, H. Buijs, D.G. Murcray, F.J. Murcray, and L.A. Sromovsky, (for 6th International Conference on Fourier Transform Spectroscopy, Vienna, Austria, 24-28 August 1987) Mikrochimica Acta, in Press 1988.
- Ref 2. "Radiometric Calibration of IR Interferometers: Experience from the High-resolution Interferometer Sounder (HIS) Aircraft Instrument", H.E. Revercomb, H. Buijs, H.B. Howell, R.O.

- Knuteson, D.D. LaPorte, W.L. Smith, L.A. Sromovsky, and H.W. Woolf, Presented at International Workshop on Remote Sensing Retrieval Methods, Williamsburg, Virginia, 15-18 December, for publication in Advances in Remote Sensing Retrieval Methods, A. Deepak Publishing, Hampton, Virginia, in Press, 1988.
- Ref 3. "Radiometric Calibration of IR Fourier Transform Spectrometers: Solution to a Problem with the High Resolution Interferometer Sounder", H.E. Revercomb, H. Buijs, H.B. Howell, D.D. LaPorte, W.L. Smith, and L.A. Sromovsky, Applied Optics, 27, 3210-3218, 1988.
- Ref 4. "Improved Geostationary Satellite Soundings for the Mesoscale Weather Analysis/Forecast Operation", W.L. Smith, H.M. Woolf, H.B. Howell, H.-L. Huang and H.E. Revercomb, Proc. Symp. Mesoscale Analysis and Forecasting, Vancouver, Canada, 17-19 August, ESA SP-282, 79-83, 1987.
- Ref 5. "HIS - A High Resolution Atmospheric Sounder", W.L. Smith, H.M. Woolf, H.B. Howell, H.E. Revercomb, and H.-L. Huang, Paper presented at the 21st International Symposium on Remote Sensing of Environment, Ann Arbor, Michigan, 26-30 October, 1987.
- Ref 6. "The Simultaneous Retrieval of Atmospheric Temperature and Water Vapor Profiles - Application to Measurements with the High-resolution Interferometer Sounder (HIS)", W.L. Smith, H.M. Woolf, H.B. Howell, H.-L. Huang, and H.E. Revercomb, Presented at International Workshop on Remote Sensing Retrieval Methods, Williamsburg, Virginia, 15-18 December, for publication in Advances in Remote Sensing Retrieval Methods, A. Deepak Publishing, Hampton, Virginia, in Press, 1988.
- Ref 7. "High Resolution Interferometer Sounding - The Retrieval of Atmospheric Temperature and Water Vapor Profiles", Third Conference on Satellite Meteorology and Oceanography of the AMS, Anaheim, California, 1-5 February, 1988.

The first reports of the performance and results from the HIS aircraft instrument were made at the radiation conference in Williamsburg, as referenced below:

"HIS - Remote Sensing from the NASA U-2 Aircraft", W. L. Smith, H. E. Revercomb, H. B. Howell, H. M. Woolf, D. LaPorte, H. Buijs, J. N. Berube, F. Murcray, and D. Murcray, paper 10.5 presented at the Second Conference on Satellite Meteorology/Remote Sensing and Applications, Williamsburg, VA, 13-16 May, 1986.

"High-resolution Interferometer Sounder (HIS)", W. L. Smith and H. E. Revercomb, poster talk 3B.6 presented at the Sixth Conference on Atmospheric Radiation, Williamsburg, VA, 13-16 May, 1986.



Figure 1. HIS Aircraft instrument on cart with U-2 aircraft in background. The left half contains the optics with interferometer and detector/dewar assembly and the right half contains the electronics and data recorder.

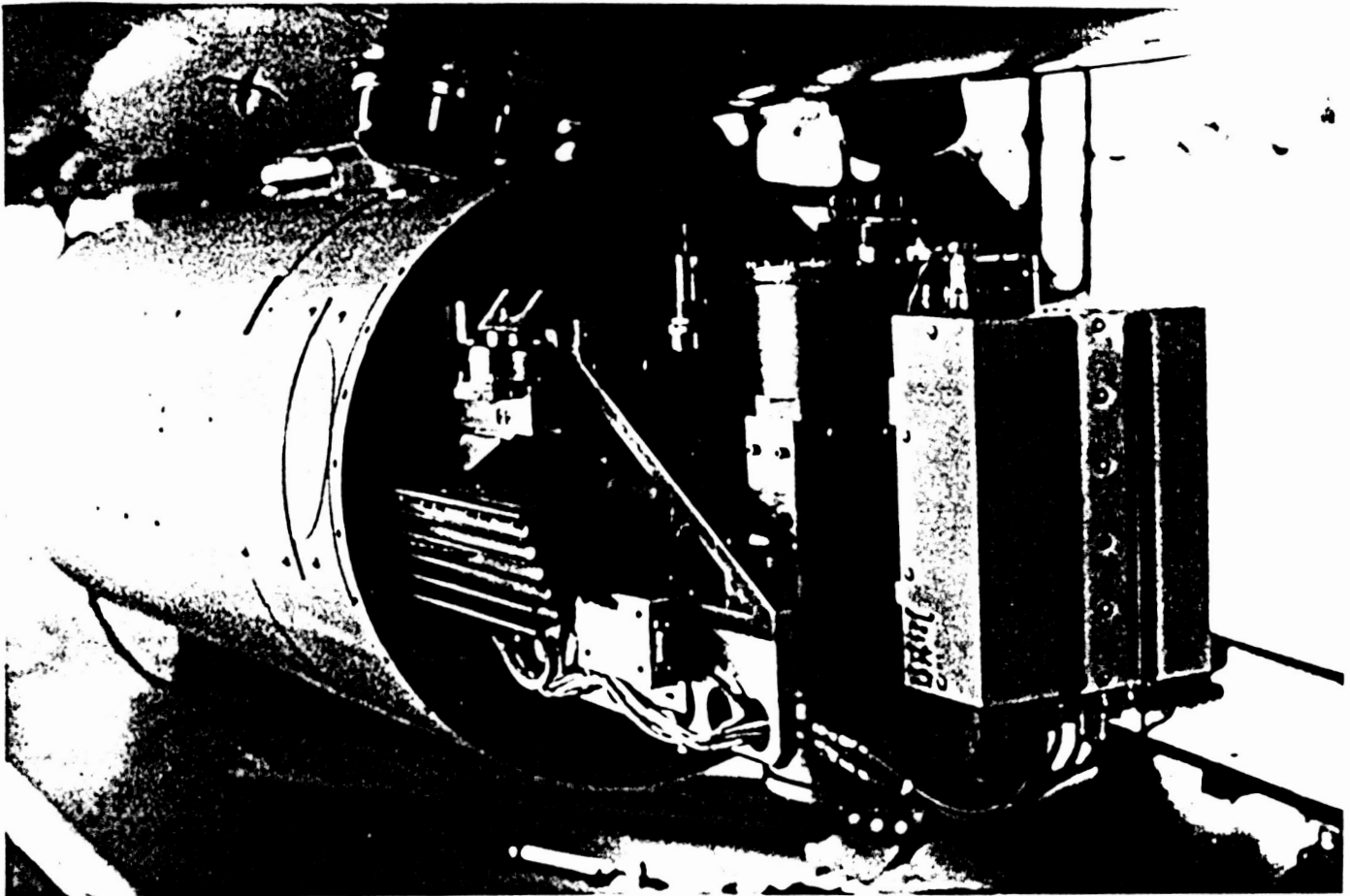

Figure 2. Instrument mounted on ER-2 underbelly with pod front cone removed.

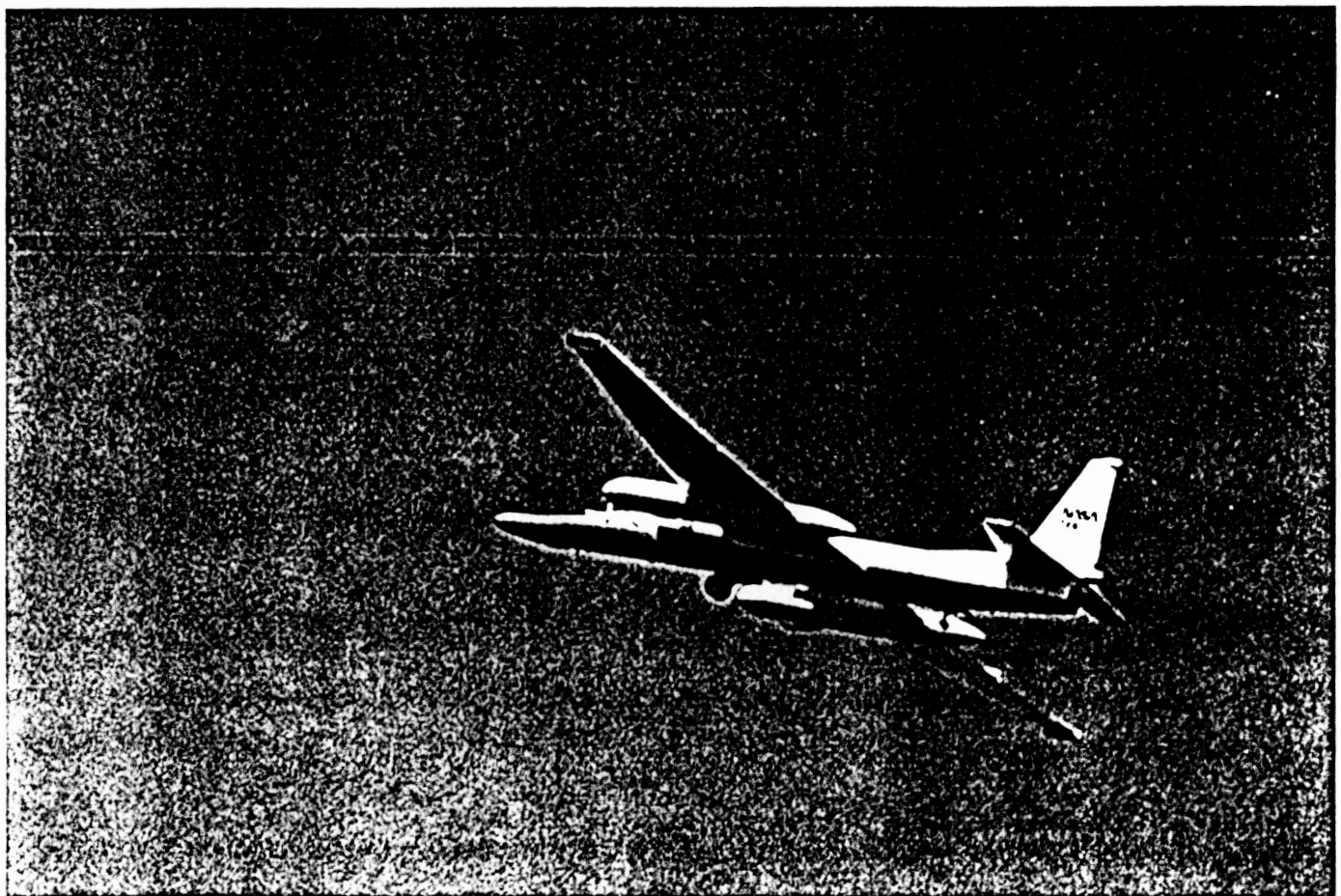

Figure 3. HIS in ER-2 underbelly pod shown during takeoff.

**ORIGINAL PAGE IS  
OF POOR QUALITY**



Figure 4. BOMEM Interferometer.

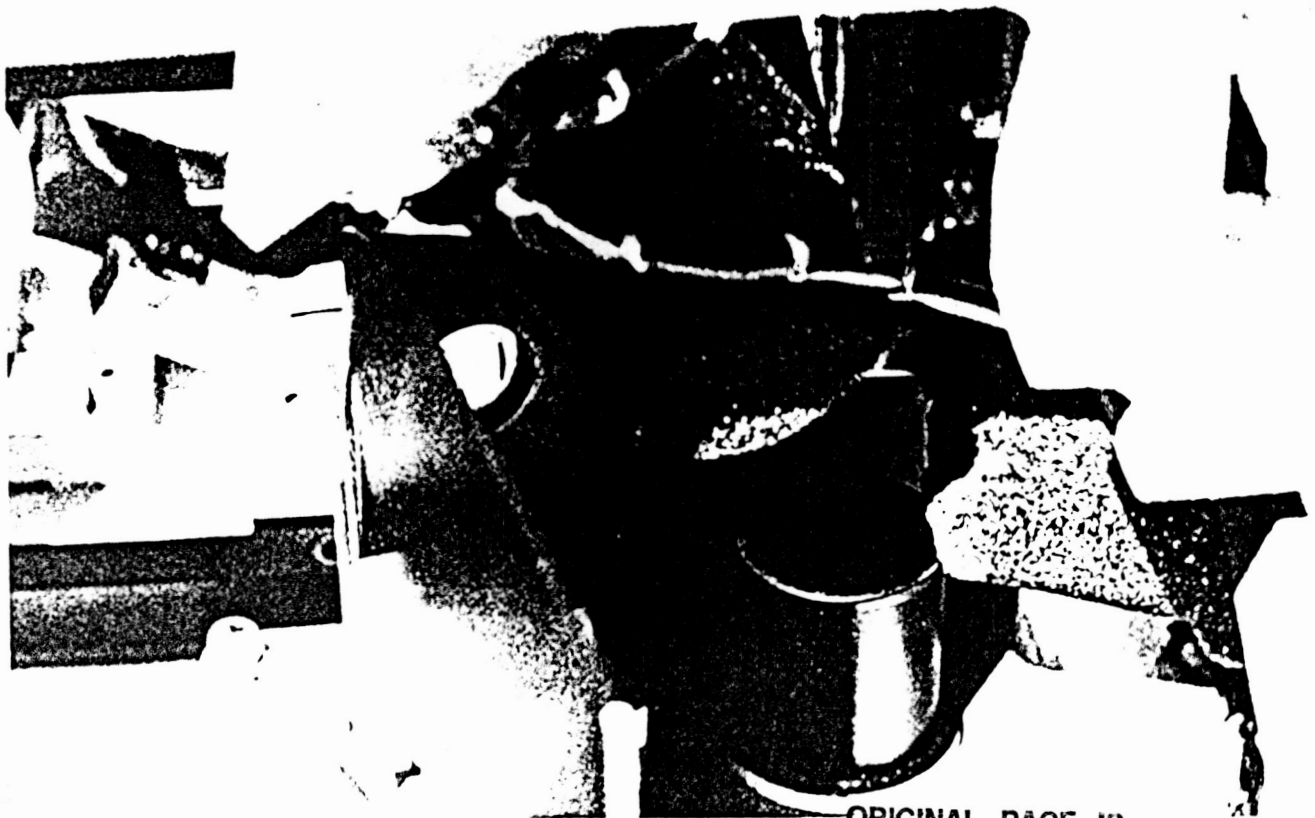

Figure 5. Calibration blackbodies.

ORIGINAL PAGE IS  
OF POOR QUALITY

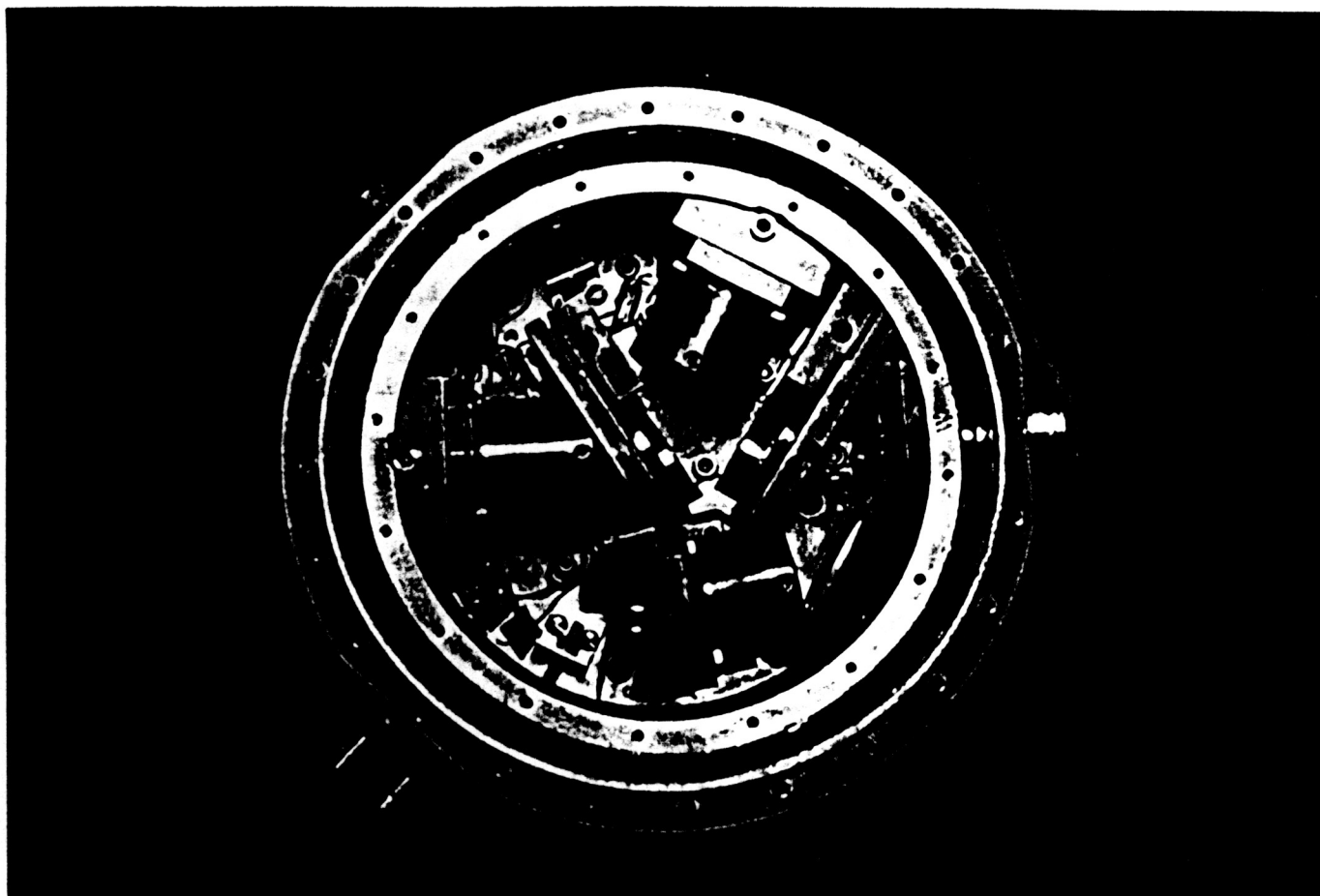

Figure 6. Inside of detector/dewar assembly containing three separate Si:Ar detectors and associated optics plus two beamsplitters.

ORIGINAL PAGE IS  
OF POOR QUALITY



Ref 1. "High-Altitude Aircraft Measurements of Upwelling IR Radiance: Prelude to FTIR from Geosynchronous Satellite", H.E. Revercomb, D.D. LaPorte, W.L. Smith, H. Buijs, D.G. Murcray, F.J. Murcray, and L.A. Sromovsky, (for 6th International Conference on Fourier Transform Spectroscopy, Vienna, Austria, 24-28 August 1987) Mikrochimica Acta, in Press 1988.

ORIGINAL PAGE IS  
OF POOR QUALITY

# HIGH-ALTITUDE AIRCRAFT MEASUREMENTS OF UPWELLING IR RADIANCE:

## PRELUDE TO FTIR FROM GEOSYNCHRONOUS SATELLITE

H.E.Revercomb, D.D.LaPorte<sup>1</sup>, and W.L.Smith  
H.Buijs<sup>2</sup>, D.G.Murcray<sup>3</sup>, F.J.Murcray<sup>3</sup>, and L.A.Sromovsky

Space Science and Engineering Center, University of Wisconsin,  
1225 West Dayton Street, Madison WI 53706 USA

<sup>1</sup>Santa Barbara Research Center, Goleta, California 93017 USA

<sup>2</sup>BOMEM, Vanier, Quebec, Canada G1M2Y2

<sup>3</sup>University of Denver, Denver Colorado 80208 USA

### 1. INTRODUCTION

Radiometrically accurate observations of upwelling radiance at 20 km above the earth's surface have been made for meteorological applications from the NASA U-2/ER-2 research aircraft. The objectives are to (1) demonstrate the capability of an interferometer to measure precisely the thermal emission spectrum with a resolving power on the order of  $10^3$  and (2) provide spectra over varied weather conditions to explore the full potential of high resolution IR data for atmospheric remote sensing. The primary focus is on retrieval of temperature and water vapor profiles with substantially higher vertical resolution and accuracy than is possible from the low spectral resolution measurements of filter radiometer sounding instruments on current weather satellites [1]. A primary goal is the implementation of high spectral resolution instruments on geosynchronous satellites to provide greatly improved meteorological observations for mesoscale forecasting (Joint support was provided by NOAA/NESDIS and NASA) [2]. Valuable information on the radiation budget, minor constituent distributions, and the radiative properties of the land surface and clouds would also be provided.

### 2. INSTRUMENT DESCRIPTION

The High-resolution Interferometer Sounder (HIS) for the NASA U-2/ER-2 aircraft views directly downward from inside a pod (about 3 m long and 0.5 m in diameter) mounted either under the wing or under the center line of the fuselage on the ER-2. Operating mode changes for thermal and recorder control are switch-selected by the pilot. Many of the important specific parameters of the design are listed in Table 1.

Calibration is accomplished by viewing two high emissivity blackbodies, servo controlled at altitude to 300 K and about 240 K. After 12 scans of the earth over the full range of optical path, a 45 degree scene switching mirror rotates the field-of-view from the open earth viewing port to give 4 scans of the hot and 4 scans of the cold blackbodies. The blackbodies, built and calibrated by Eppley Labs, are blackened cavities with thermoelectric cooler/heaters for temperature control and PRTs for monitoring. The temperature of the interferometer optics is not actively controlled.

The BOMEM Michelson interferometer [3] as modified for this application provides double sided interferograms from both scan directions. Its auto-alignment system makes it possible to operate in the ambient thermal environment of the pod and in very close proximity to the aircraft jet engine; optical alignment has never been lost. The optical bench is shock mounted to damp high frequency vibration and the interferometer is evacuated to protect the beamsplitter during descent.

The three spectral channels, covering most of the region from 3.8 to 16.6 microns (Table 1), are split inside a single LHe dewar which contains three sets of bandpass cold

filters, focussing optics, and arsenic-doped silicon detectors. The preamplifiers are external and operate near the ambient pod temperature of about 260 K. The gain of each channel is fixed and the signals are digitized with a 16 bit A/D. Onboard numerical filtering is used to reduce the sample rate from the HeNe laser rate by factors of 14, 8 and 8 in bands I, II and III.

The data system is controlled with a 6809 microprocessor based system built at the University of Denver. The three channels of interferometer data and housekeeping parameters are combined and recorded on formatted cassette tapes. Two drives with a capacity of 67 MBytes each are used to provide 9 hours of continuous recording time.

Processing of selected data in the field is performed on IBM XT/AT microcomputers. Data is transferred to hard disk and is processed with custom software which displays the measured interferograms and corresponding spectra, and performs calibration to yield radiance or brightness temperature spectra. The calibration procedure uses full complex spectra to avoid errors that can arise from radiance emitted by the warm interferometer [4].

### 3. RADIOMETRIC PERFORMANCE

The RMS detector noise for a single 6 second scan determined from in-flight calibration data is shown in Fig. 1. For bands I and II the noise is background limited, with radiation from the instrument providing most of the photons. Band III noise is considerably higher, with a contribution from about  $2150\text{-}2350\text{ cm}^{-1}$  which is not detector noise.

The other type of noise encountered in flight is sample-position-error noise caused by the effect of aircraft vibrations on the velocity of the scanning Michelson mirror. Since it originates from very near ZPD, this noise is highly correlated with wavenumber, causing a small rocking of the spectra. It is absent on the ground and would not be present in a spacecraft application. Even in the hostile aircraft environment, this noise can be made small as shown in Fig. 2 for operation under the centerline of the ER-2. The amplitude of this noise varies with instrument configuration, and is significantly lower when the HIS is located under the wing.

Accurate radiometric calibration over the full spectral range was demonstrated on the ground using a third blackbody. A liquid nitrogen blackbody was used as the cold reference, one on-board blackbody served as the 300 K hot reference, and the temperature of the other on-board blackbody (set between 260 and 280 K) was determined. The unknown temperature can be determined routinely to within about 0.2 to 0.4 K. This procedure relies on a careful optical design and alignment to prevent OPD dependence of the responsivity, which would degrade the high resolution integrity of the spectra. Self apodization is kept small by the relatively small field-of-view (FOV) of the interferometer, and can be accounted for accurately. Additional errors could be present in flight, but comparisons with aircraft altitude temperatures and water surface temperatures are generally within 1 K and an accuracy of  $< 0.5^\circ\text{C}$  is possible, except for regions of low brightness temperature in the 4.3 micron  $\text{CO}_2$  band.

### 4. FLIGHT EXPERIENCE AND RESULTS

The HIS aircraft instrument was flown over many different atmospheric conditions in 1986. In May, two flights were made with clear conditions over the Kitt Peak observatory in Arizona, while simultaneous absorption measurements were made with Brault's interferometer on the McMath Solar Telescope [5]. In June and July, 20 flights were made as part of the NASA COHMEX experiment conducted near NASA Marshall, an intensive study of convective storms and their precursor conditions. In October and November, 10 flights were made in support of the NASA FIRE experiment in Wisconsin to study the radiative impact of cirrus clouds.

Figure 3 shows sample spectra from all three bands compared to those calculated using radiosonde data with the AFGL FASCODE2 line-by-line program [6]. The finite FOV of the interferometer is accounted for in the calculated spectra. The major differences are due to incomplete information on the actual conditions of the observed atmosphere and small deficiencies in the line-by-line calculations. Especially in the two longer wavelength bands, noise and calibration errors are not believed to be significant.

## 5. CONCLUSIONS

The success of the HIS aircraft measurements has recently led NOAA to support a study at the University of Wisconsin of the feasibility of modifying some of the next series of GOES sounding instruments by replacing their filter wheels with interferometers. Also, the capabilities of the aircraft instrument are unique and should be applied to atmospheric research projects of many types for several years.

## 6. REFERENCES

- [1] W.L.Smith, H.E.Revercomb, H.B.Howell, H.M.Woolf, *International Radiation Symposium '84: Current Problems in Atmospheric Radiation*, Edited by Giorgio Fiocco, A. Deepak Publishing, Hampton, Virginia, 1984, p.388.
- [2] W.L.Smith, H.E.Revercomb, H.B.Howell, H.M.Woolf, *Fifth Conference on Atmospheric Radiation*, American Meteorological Society, Boston, Massachusetts, 1983, p.1
- [3] H.Buijs, *SPIE*, 1979, 191, 116.
- [4] H.E.Revercomb, H.Buijs, H.B.Howell, D.D.LaPorte, W.L.Smith, L.A.Sromovsky, Submitted to *Applied Optics*, 1987.
- [5] J.W.Brault, Proceedings, *ESO/CERN Conference on Auxiliary Instrumentation for Large Telescopes*, Edited by S.Lusten and A. Reiz, CERN, Geneva, 1972.
- [6] S.A.Clough, F.X.Kneizys, E.P.Shettle, G.P.Anderson, *Sixth Conference on Atmospheric Radiation*, American Meteorological Society, Boston, Massachusetts, 1986, p.141.

ORIGINAL PAGE IS  
OF POOR QUALITY

Table I. Characteristics of the HIS Aircraft Instrument

Spectral range (cm <sup>-1</sup> ):	
Band I	590-1070
Band II	1040-1930
Band III	2070-2750
Field of view diameter (mr):	
Telescope	100
Interferometer	30
Blackbody Reference sources:	
Emissivity	>0.998
Aperture diameter (cm)	1.5
Temperature stability (K)	±0.1
Auto-aligned Interferometer:	modified BOMEM BBDA2.1
Beamsplitter:	
Substrate	KCl
Coatings (1/4 λ at 3.3 μm)	Ge+Sb <sub>2</sub> S <sub>3</sub>
Maximum delay (double sided)-current configuration (cm)	
Band I (hardware limit is ±2.0)	±1.8
Bands II & III (limited by data system)	+1.2,-0.8
Michelson mirror optical scan rate (cm/s):	0.6-1.0
Aperture stop (at interferometer exit window):	
Diameter (cm)	4.1
Central obscuration area fraction	0.17
Area (cm <sup>2</sup> )	10.8
Area-solid angle product (cm <sup>2</sup> -sr):	0.0076
Detectors:	
Type	Ar doped Si
Diameter (cm)	0.16
Temperature (K)	6

\* The ranges shown are design ranges. The current bandpass filters were chosen from available stock filters, and will be changed as new filters are acquired.

ORIGINAL PAGE IS  
OF POOR QUALITY

## FIGURE CAPTIONS

Fig. 1. Detector noise.

Fig. 2. Sample position error noise for 2 November 1986 ER-2 flight. On the ground, and even in the alternative under-wing configuration, these errors are smaller than detector noise.

Fig. 3. Brightness temperature spectra from 15 June 1986 flight over Tennessee compared to calculated spectra. The measured spectra are the mean of the spectra from one forward and one backward OPD scan.

ORIGINAL PAGE IS  
OF POOR QUALITY

ORIGINAL PAGE IS  
OF POOR QUALITY

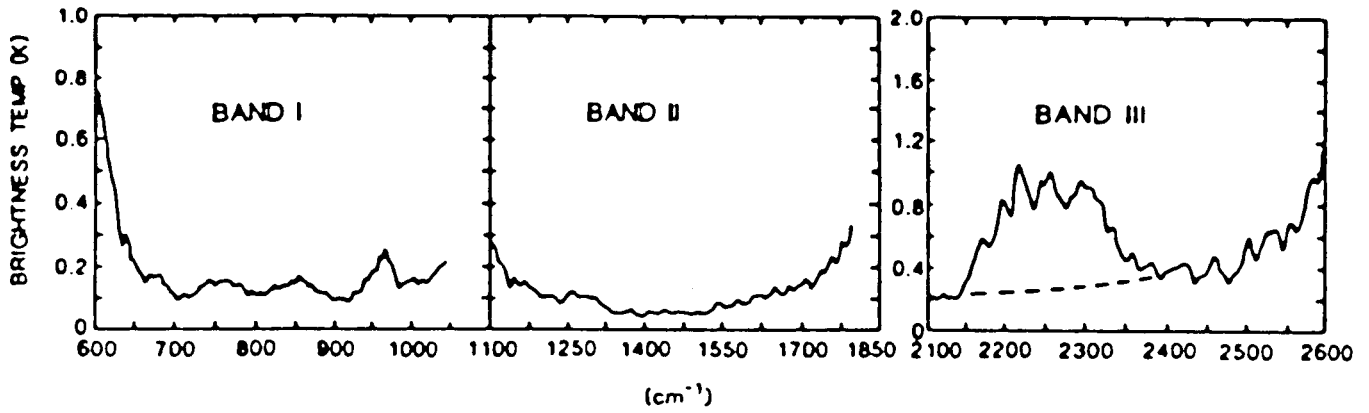

Figure 1. Detector noise.

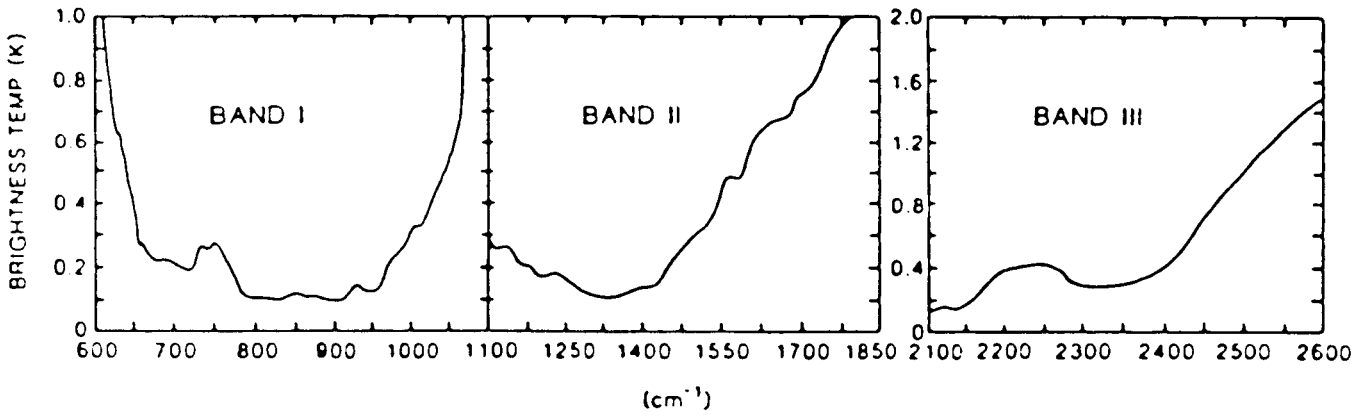

Figure 2. Sample position error for 2 November 1986 ER-2 flight.

ORIGINAL PAGE IS  
OF POOR QUALITY

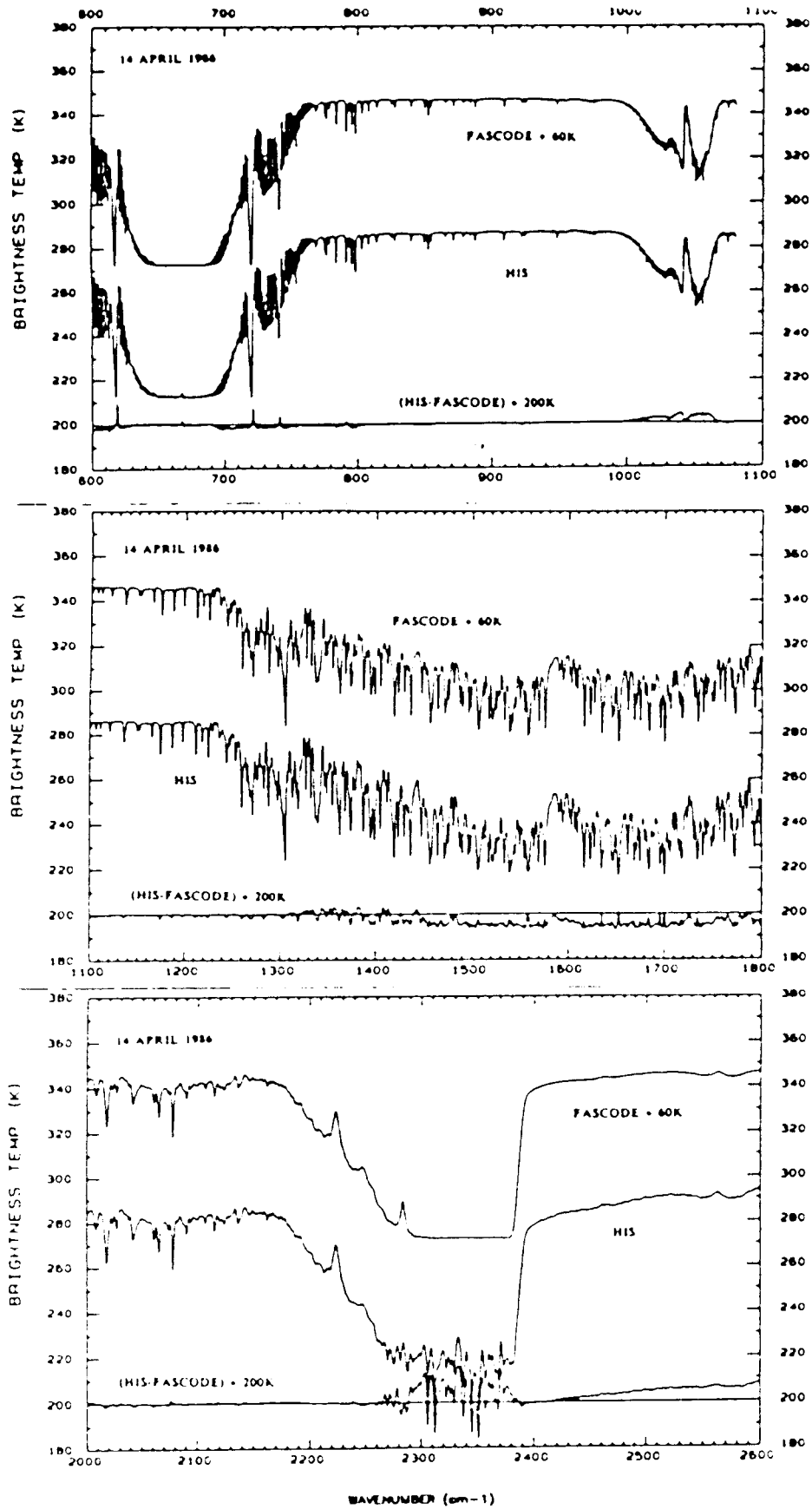

FIGURE 3



Ref 2. "Radiometric Calibration of IR Interferometers: Experience from the High-resolution Interferometer Sounder (HIS) Aircraft Instrument", H.E. Revercomb, H. Buijs, H.B. Howell, R.O. Knuteson, D.D. LaPorte, W.L. Smith, L.A. Sromovsky, and H.W. Woolf, Presented at International Workshop on Remote Sensing Retrieval Methods, Williamsburg, Virginia, 15-18 December, for publication in Advances in Remote Sensing Retrieval Methods. A. Deepak Publishing, Hampton, Virginia, in Press, 1988.

ORIGINAL PAGE IS  
OF POOR QUALITY

ORIGINAL PAGE IS  
OF POOR QUALITY

RADIOMETRIC CALIBRATION OF IR INTERFEROMETERS: EXPERIENCE FROM  
THE HIGH-RESOLUTION INTERFEROMETER SOUNDER (HIS) AIRCRAFT INSTRUMENT

H.E. Revercomb<sup>1</sup>, H. Buijs<sup>1</sup>, H.B. Howell<sup>2</sup>, R.O. Knuteson,  
D.D. LaPorte<sup>3</sup>, W.L. Smith, L.A. Sromovsky, and H. W. Woolf<sup>2</sup>  
Space Science and Engineering Center,  
Madison, WI 53706 USA

ABSTRACT

An accurately calibrated Fourier transform spectrometer has been developed to measure the upwelling infrared emission of the earth from high-altitude NASA research aircraft as part of the HIS program to improve the vertical resolution of temperature and humidity retrievals. The HIS instrument has demonstrated that the radiometric accuracy goals for high resolution sounding (1°C absolute and 0.1°C RMS reproducibility) can be achieved. Accurate radiometric calibration over the full spectral range was demonstrated on the ground using a third reference blackbody. The unknown temperature of the third blackbody is determined routinely to within 0.2 K of its measured temperature. Achieving this level of accuracy in one of the three spectral bands required developing a technique for cancelling the effects of an anomalous phase response in that band. Additional errors could be present in flight, but comparisons with aircraft altitude temperatures and water surface temperatures are generally within about 1 K. An accuracy of < 0.5 °C is possible, except for regions of low brightness temperature in the 4.3 micron CO<sub>2</sub> band. Comparisons of HIS earth-emitted spectra with line-by-line calculations using the AFGL FASCODE demonstrate the high radiometric accuracy of measured high spectral resolution features.

1. INTRODUCTION

The aircraft model High-resolution Interferometer Sounder, designed for the NASA U-2 research aircraft, has demonstrated the scientific value of radiometrically-precise high spectral resolution emission measurements (Smith et al., 1987a, 1987b). The instrument has been flown reliably on over 40 flights including two major NASA field experiments. The HIS participated, with many other atmospheric sensing instruments, in the COMbined Huntsville Meteorological EXperiment (COHMEX) for studying severe storms and the First ISCCP

---

<sup>1</sup> BOMEM Inc., Ville de Vanier, Quebec, Canada G1M2Y2

<sup>2</sup> NOAA/NESDIS Systems Design and Appl. Branch, Madison WI 53706

<sup>3</sup> Santa Barbara Research Center, Goleta, CA 93117

Regional Experiment (FIRE) for studying the effect of cirrus clouds on climate. The unique ability of this instrument to measure accurately the emission spectrum from a flexible, high-altitude platform with a large complement of other instrumentation should make it an important resource for many types of experiments for several years. The success of the aircraft instrument has led to a current effort to develop a spacecraft instrument which will provide improved operational soundings from geosynchronous orbit (Smith et al., 1983, 1984) by as early as 1995.

As background for the calibration discussion, the primary parameters of the HIS aircraft instrument are summarized in Table 1. The specific implementation for the aircraft bears little resemblance to a spacecraft instrument, but the principles are the same. Also, the instrument noise performance, which along with the calibration defines the radiometric performance, is shown in Fig. 1 taken from Revercomb et al. (1987). The detector noise level derived from the variance of blackbody brightness temperatures in flight is very similar for both the hot and cold blackbodies. The noise performance of the short wavelength Band III is not as good as that of the other two bands, with an extra contribution between 2150 and 2350  $\text{cm}^{-1}$  from pickup in the analog electronics. However, the RMS noise for most of the spectral range of bands I and II is very low, generally less than  $0.2^\circ\text{C}$  for a single 6-second interferometer scan. The additional noise arising from sample-position errors for the HIS varies with the aircraft configuration. It is caused by undamped vibrations from the aircraft engine and varies from substantially smaller to somewhat larger than the detector noise. This source of noise is small on the ground and would be negligible in a spacecraft instrument.

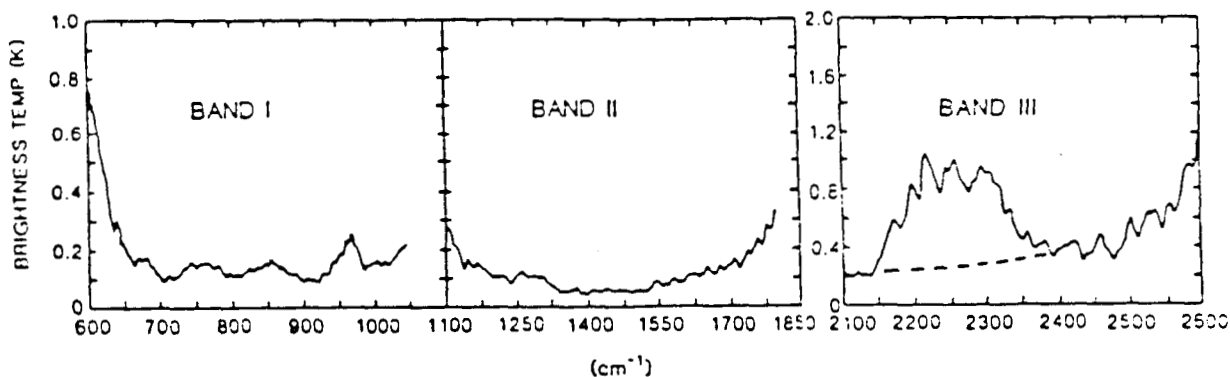

Figure 1. Detector noise for the three HIS spectral bands.

## 2. RADIOMETRIC CALIBRATION AND VERIFICATION

The basic approach for determining absolute radiances from the HIS nadir-viewing interferometer is the same as that used for filter radiometers and has been used successfully for other interferometric applications. (Hanel et al., 1980, 1972, 1971, 1970; LaPorte and Howitt, 1982). The detectors and electronics are designed to yield an output which is linear in the incident radiance for all wavenumbers in the optical passband of the instrument. Two blackbody reference

TABLE 1. CHARACTERISTICS OF THE HIS AIRCRAFT INSTRUMENT  
(after Revercomb et al, 1987, 1988)

Spectral range (cm <sup>-1</sup> )*:	
Band I	590-1070
Band II	1040-1930
Band III	2070-2750
Field of view diameter (mrad):	
Telescope	100
Interferometer	30
Blackbody Reference sources:	
Emissivity	>0.998
Aperture diameter (cm)	1.5
Temperature stability (K)	±0.1
Temperatures (K)	240, 300
Auto-aligned Interferometer:	modified BOHEM: SBDA2.1
Beamsplitter:	
Substrate	KCl
Coatings (1/4 λ at 3.3 μm)	Ge-Sb <sub>2</sub> S <sub>3</sub>
Maximum delay (double sided)-current configuration (cm)	
Band I (hardware limit is ±2.0)	±1.8
Bands II & III (limited by data system)	+1.2,-0.8
Michelson mirror optical scan rate (cm/s):	0.6-1.0
Aperture stop (at interferometer exit window):	
Diameter (cm)	4.1
Central obscuration area fraction	0.17
Area (cm <sup>2</sup> )	10.8
Area-solid angle product (cm <sup>2</sup> -sr):	0.0076
Detectors:	
Type	Ar doped Si
Diameter (cm)	0.16
Temperature (K)	6
Nominal instrument temperature (K):	260

\* The ranges shown are design ranges. The current bandpass filters were chosen from available stock filters, and will be changed as new filters are acquired.

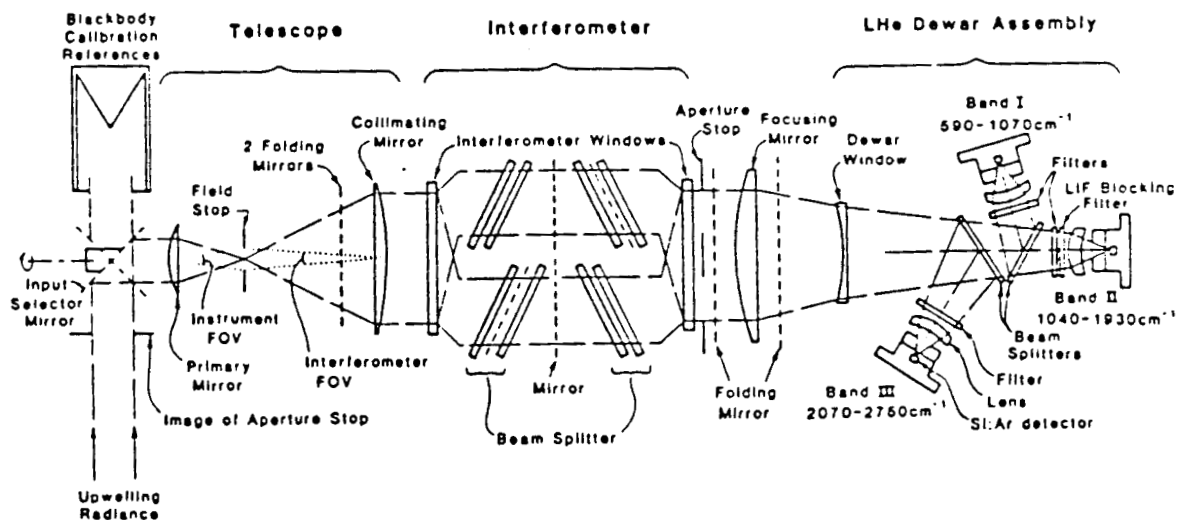

Figure 2. Schematic of HIS optics. Primary, collimating and focusing mirrors are shown as lenses (after Revercomb et al., 1988).

sources are viewed to determine the slope and offset which define the linear instrument response at each wavenumber.

In the HIS U-2 instrument, calibration observations of the two on-board reference blackbodies are made every two minutes. There are 4 double-sided optical-path scans of each reference source for every 12 scans of the earth. As shown in Fig. 2 which summarizes the optical configuration, the blackbodies are viewed by rotating the telescope field-of-view from below the aircraft to inside a blackbody aperture using a 45° plane mirror. There are no uncalibrated optical surfaces, since the earth is viewed through an open aperture in the pod which provides an aerodynamic shell.

The small size of the optical beam at the blackbody positions makes the design of accurate radiation standards relatively easy. The reference blackbodies are thermoelectrically-controlled, blackened, copper cavities (Fig. 3). The insulated copper walls of the blackbody cavities give good temperature uniformity, and because of the cavity effect, the normal emissivity is very close to one (Table 1). The temperatures are sensed with accurately calibrated platinum resistance thermometers (PRTs) embedded in the base of each cavity (during testing, a second PRT in the side of the cavity was used to verify adequate temperature uniformity).

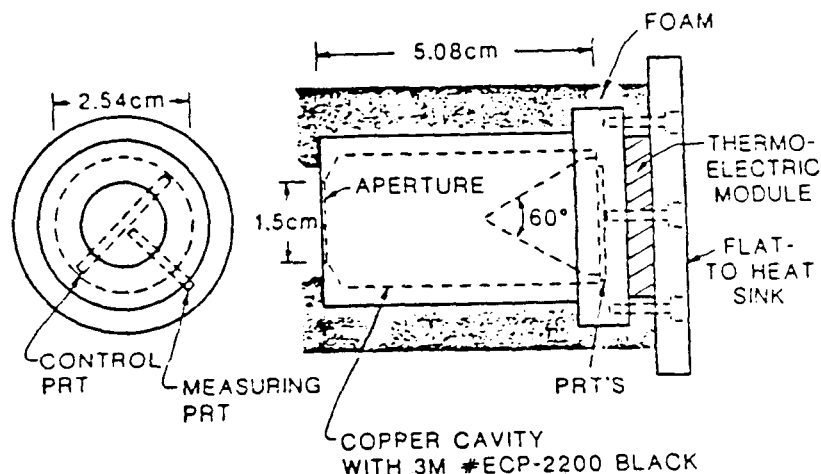

Figure 3. Blackbody reference cavity design.

One important, additional requirement when applying a two-point calibration with blackbody references to an interferometer, as opposed to an instrument measuring spectra directly, is that the instrument responsivity should be independent of optical delay (or that any delay dependences should be accurately known). Avoiding sources of delay dependent response was a major objective in designing the HIS instrument. To accomplish this, care was taken in the optical stop design and alignment to prevent the effective aperture stop size from changing with motion of the Michelson mirror. The best location for the aperture stop, which is focused on the detectors, was found to be at the exit window of the interferometer module (see Fig. 2). Further, the field-of-view (FOV) of the interferometer is restricted to 30 mrad to limit self-apodization.

Now, turning to the mathematical expressions for the calibration, we present the new formulation for calibration which correctly accounts for the anomalous phase response observed in the HIS Band I (Revercomb et al., 1988). Assuming linearity as expressed above, the output interferogram  $F$  can be expressed in terms of the incident spectral radiance  $L_\nu$  as follows, using a continuous representation:

$$F(x) = \frac{1}{2} \int_{-\infty}^{\infty} C_\nu e^{i2\pi\nu x} d\nu \quad (1)$$

where the uncalibrated complex spectrum ( $C_\nu = C_{-\nu}$ ) is given by

$$C_\nu = r_\nu (L_\nu + L_\nu^0 e^{i\phi^0(\nu)}) e^{i\phi(\nu)} \quad (2)$$

and where  $x$  is optical path difference (delay),  $\nu$  is wavenumber,  $\phi(\nu)$  is the normal phase response to external radiation,  $\phi^0(\nu)$  is the anomalous phase response from instrument emission,  $r_\nu$  is the responsivity of the instrument, and  $L_\nu^0$  is the offset from instrument emission (referred to input).

Equation (2) expresses the linear relationship between the uncalibrated spectrum and spectral radiance. The two unknowns to be determined from the two calibration observations are the responsivity and the offset radiance. The offset radiance defined here is the radiance which, if introduced at the input of the instrument, would give the same contribution as the actual emission from various parts of the optical train.

The phase characterizes the combined optical and electrical dispersion of the instrument. Note that both a normal and an anomalous phase are explicitly represented here. This is to allow for the possibility, encountered with the HIS band I, that the phase for radiance from the source is different from the phase for background emissions.

It is clear from Eq. (2) that the anomalous phase contribution can be eliminated along with the instrument radiance offset by differencing complex spectra from different sources. The difference spectra are identical to the difference spectra which would result if there were no anomalous phase contribution. The equations for the difference spectra are

$$C_\nu - C_{c\nu} = r_\nu [L_\nu - B_\nu(T_c)] e^{i\phi(\nu)} \quad (3)$$

$$C_{h\nu} - C_{c\nu} = r_\nu [B_\nu(T_h) - B_\nu(T_c)] e^{i\phi(\nu)} \quad (4)$$

where  $B_{\nu}$  is the Planck blackbody radiance, and subscripts h and c label the quantities associated with the hot and cold blackbody. [Note that, for simplicity, the blackbodies are assumed to have unit emittance here. To account for actual emittances  $\epsilon$ , the Planck radiances should be replaced with  $\epsilon B_{\nu} + (1-\epsilon)B_{\nu}(T_a)$  where  $T_a$  is the ambient temperature.]

The new expression for the responsivity, which follows immediately from Eq. (4) by taking the magnitude of both sides, is

$$r_{\nu} = |C_{h\nu} - C_{c\nu}| / [B_{\nu}(T_h) - B_{\nu}(T_c)] \quad (5)$$

The offset which follows directly by substituting the responsivity into Eq. (2) is

$$L_{\nu}^o e^{i\phi^o(\nu)} = C_{h\nu} e^{-i\phi(\nu)} / r_{\nu} - B_{\nu}(T_c) \quad (6)$$

Note that the offset from instrument emission given by Eq. (6) is a complex function. In the shorter wavelength bands of the HIS where the beamsplitter is largely free of absorption, the anomalous phase is essentially zero, making the offset real. However, in Band I the HIS beamsplitter absorbs as shown in Fig. 4. In addition to reducing efficiency, absorption also alters the phase response. The resulting emission from the ambient temperature beamsplitter creates coherent beams in each leg of the interferometer, with the effective point of wavefront division in a plane different from the plane for reflection. This is the source of the anomalous phase.

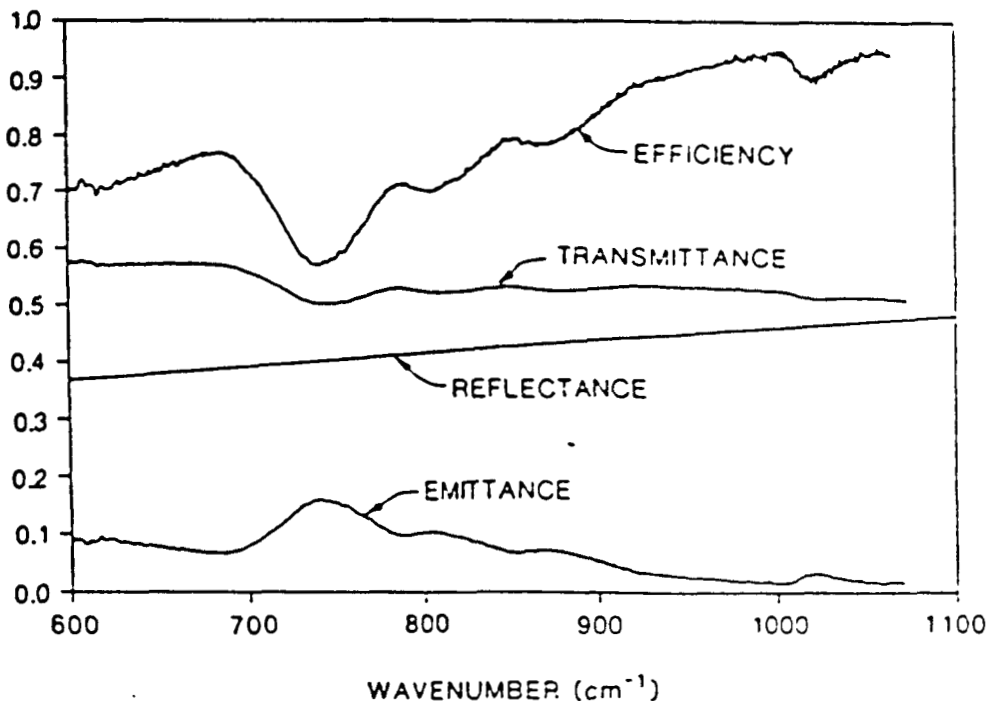

Figure 4. Characteristics of HIS beamsplitter for Band I.

Finally, the basic calibration expression which follows by taking the ratio of Eq. (3) to Eq. (4) is

$$L_{\nu} = \text{Re}[(C_{\nu} - C_{c\nu}) / (C_{h\nu} - C_{c\nu})] [B_{\nu}(T_h) - B_{\nu}(T_c)] + B_{\nu}(T_c) \quad (7)$$

For ideal spectra with no noise, this expression for the calibrated radiance would be real, since the phases of the ratioed difference spectra are the same. This cancellation of the phases avoids the square root of two noise amplification, which can be associated with taking the magnitude of spectra with non-zero phase. Because the phase of the ratio of difference spectra is zero to within the noise, the calibrated spectrum can equally well be defined in terms of the real part of the ratio (as shown), or in terms of the magnitude of the ratio.

The ground calibration tests to verify the above procedure consisted of measuring the radiance from a blackbody at approximately 280 K using calibration blackbodies at 300 K and 77 K. The results of one of these tests are shown in Fig. 5. The spectra for each of the

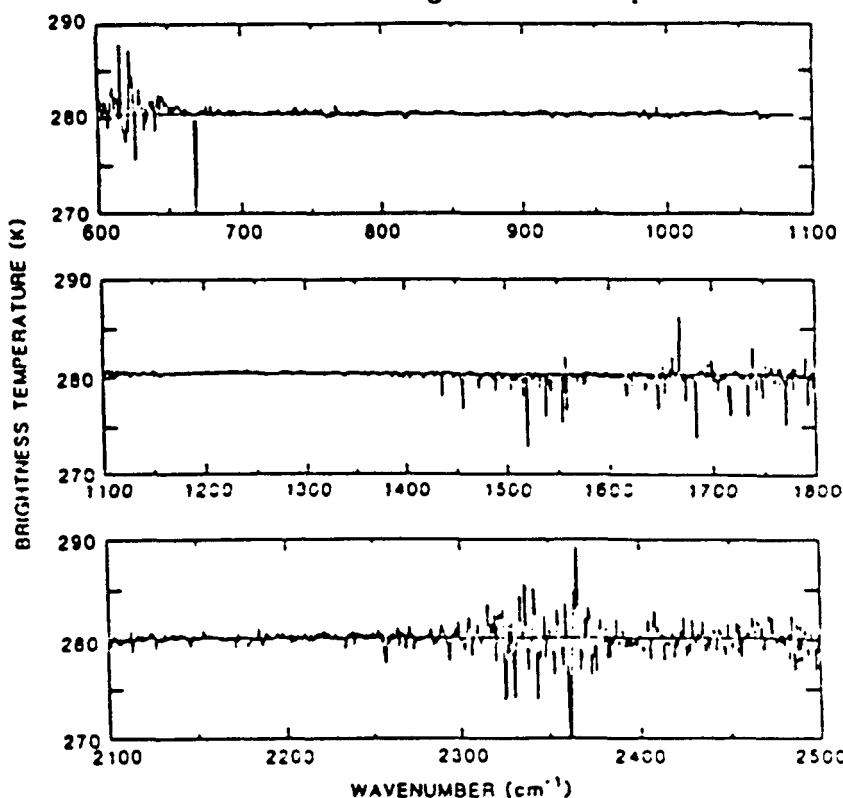

Figure 5. Laboratory calibration with source at 280.2 K (lines shown).

three HIS spectral bands are presented as brightness temperatures to make any errors stand out as a deviation from the measured blackbody temperature of 280.2 K. The deviations are almost exclusively caused by noise, in part due to operation in moist room air. The large noise between 600 and 650  $\text{cm}^{-1}$  is caused by low optical throughput in this region during this test, and has since been improved. The noise



spikes from 1450 to 1800  $\text{cm}^{-1}$  are due to water vapor absorption between the interferometer and the detectors and are not present at flight altitude (Fig. 1). Room air  $\text{CO}_2$  absorption is responsible for the increased noise amplitude between 2300 and 2400  $\text{cm}^{-1}$ . The true calibration errors from this test are only about 0.1 to 0.2 K.

### 3. EARTH EMISSION SPECTRA

To illustrate some of the features of the raw data, the complex uncalibrated spectra from a flight on 17 June 1986 are shown in Figs. 6 and 7 for Bands I and II respectively. Both the magnitude and phase are determined directly from a complex Fourier transformation of the measured two-sided interferogram. It is apparent from the magnitude spectra that the cold blackbody temperature of 245 K for these measurements is not optimum, because there are many areas where the earth spectrum is smaller than that for the cold blackbody. The objective was to run the cold blackbody at about 220 K, but we could not dissipate enough heat from the thermoelectric cooler. The extrapolation necessary for low earth radiances can lead to somewhat larger calibration errors, but the effect is not large with the high emissivity sources used on HIS.

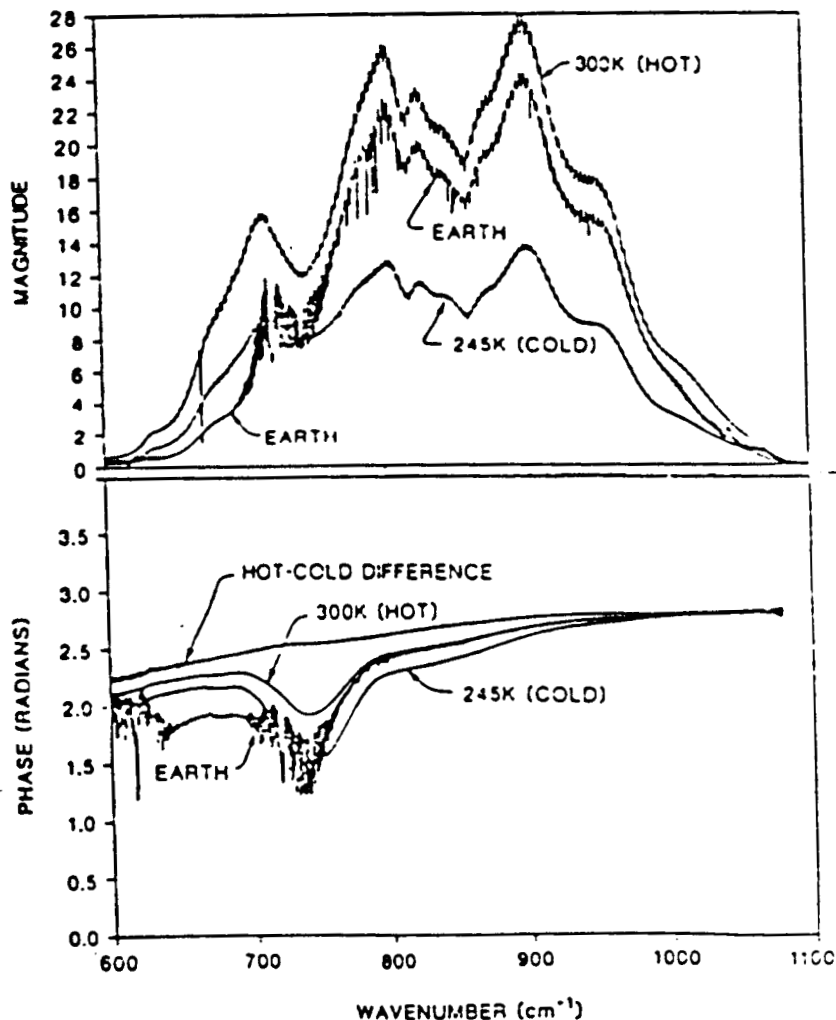

Figure 6. Magnitude and phase of Band I uncalibrated spectrum.

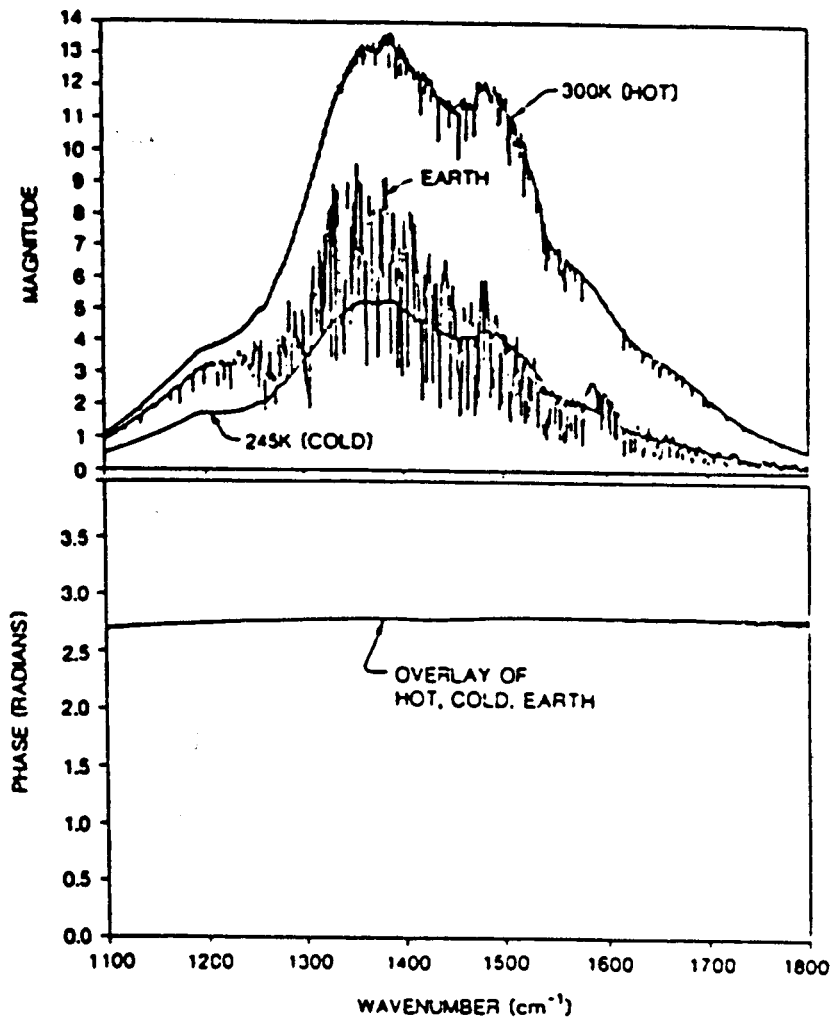

Figure 7. Magnitude and phase of Band II uncalibrated spectra.

The magnitude spectra have various features which need explanation. The general Gaussian shape of the magnitude spectra is caused by the numerical filtering which is performed in the instrument digital electronics (a hardware convolution is performed for signal-to-noise preserving sample volume reduction by factors of 14, 8, 8 in the 3 spectral bands). The sinusoidal components superimposed on the magnitude spectra are channeled spectra caused by the parallel surfaces of the arsenic-doped silicon detectors. Because the channeled spectra are very stable, they do not affect the calibrated spectra. The magnitude spectrum of the hot blackbody for Band II also shows some features for wavenumbers above  $1350 \text{ cm}^{-1}$  from the small water content at altitude, and band I shows the  $667 \text{ cm}^{-1}$   $\text{CO}_2$  Q-branch. These features are also stable and do not cause errors in the calibrated spectra.

The phase spectra for bands I and II differ markedly. For band II the phases are nearly linear and are source independent, the behavior expected with an ideal beamsplitter having zero dispersion

and with an electrical response having a pure time delay. Band I phases, on the other hand, show significant deviations from linearity, and the phase for the earth view even has high resolution structure. As mentioned earlier, these peculiar characteristics are caused by emission from the beamsplitter in band I. The high resolution structure occurs when the contribution from the earth with a well behaved phase and that from the instrument with an anomolous (but reasonably smooth) phase are combined to give a single phase.

To demonstrate the radiometric integrity of the high-resolution features of spectra from the aircraft instrument, we now give some examples (Figs. 8-10) of comparisons between calibrated earth emission spectra and spectra from line-by-line calculations. All three examples are from a single Band I spectrum made with a six-second interferometer scan on 15 June 1986 over Northern Tennessee, the first day of COHMEK. The apodized resolution is about  $0.5 \text{ cm}^{-1}$ . The only selection criterion was a clear scene with reasonably close proximity to radiosonde measurements.

The calculations, which use the AFGL FASCOD version 2 (Clough et al., 1986) and the 1986 HITRAN database line tape (Rothman et al., 1987), have only recently been completed. Now, the reduction of the full resolution FASCOD spectrum to the HIS resolution is done without any loss of accuracy. The finite field-of-view of the interferometer (Table 1) is introduced into the calculated spectra as part of the resolution reduction process. The temperature and water vapor profiles are from the average of two radiosondes about 180 km apart in the special network. The six minor constituents included besides water vapor default to the midlatitude summer model.

The generally excellent agreement of the line structure and of the water vapor continuum as well is evident in Fig. 8. There are some interesting real differences which vary slowly with wavenumber and are presumably due to surface emissivity variations or to trace constituents not yet included in the calculations. Fig. 9 shows the short wavelength side of the  $15 \mu\text{m}$   $\text{CO}_2$  band used for temperature sounding. The differences are less than about three degrees at most wavenumbers. The large feature near  $720 \text{ cm}^{-1}$  is a known deficiency of FASCOD caused by line mixing. Much of the residual difference is of the type which might be attributable to the failure of two radiosondes to accurately characterize the atmosphere.

Figure 10 shows the detailed nature of the differences for  $\text{CO}_2$  lines from the same spectral region. The agreement in shape and wavenumber alignment of the spectra is phenomenal. This is especially remarkable since the HIS wavenumber calibration here is based on the known laser wavenumber and interferometer field-of-view, without adjustment. The difference is close to an offset minus a small fraction of the spectrum. This type of difference can largely be accounted for by adjusting the temperature and lapse rate of the atmosphere, although small calibration adjustments (to the radiosonde or to the HIS) might also be indicated.

15 JUNE 1986: COHMEX

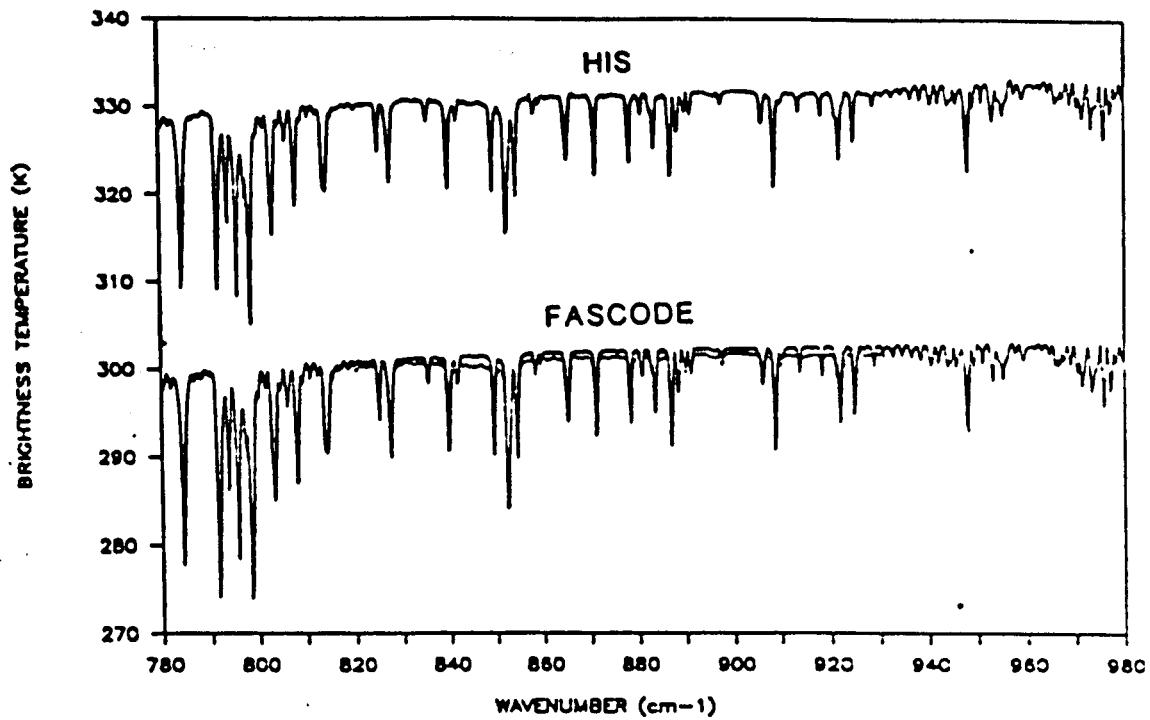

Figure 8. Comparison of measured and calculated window region spectra.

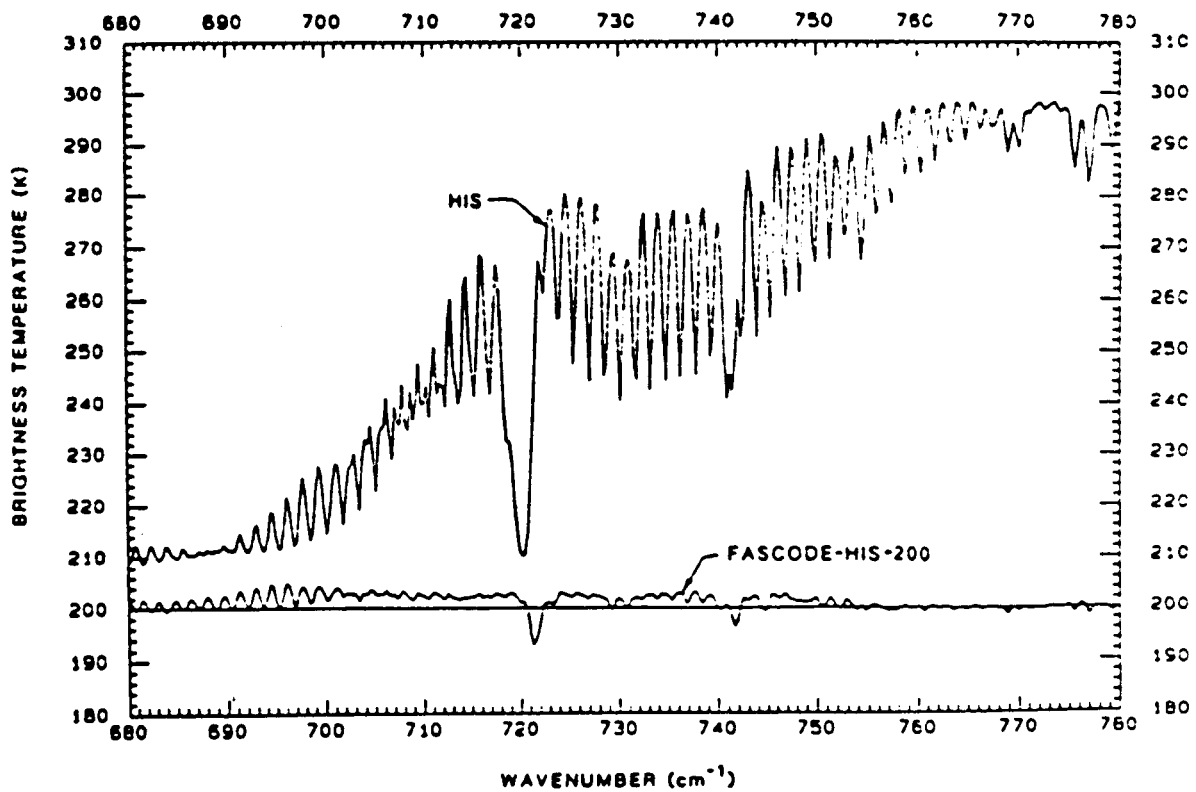

Figure 9. HIS and FASCODE compared in the 15 micron CO<sub>2</sub> band.

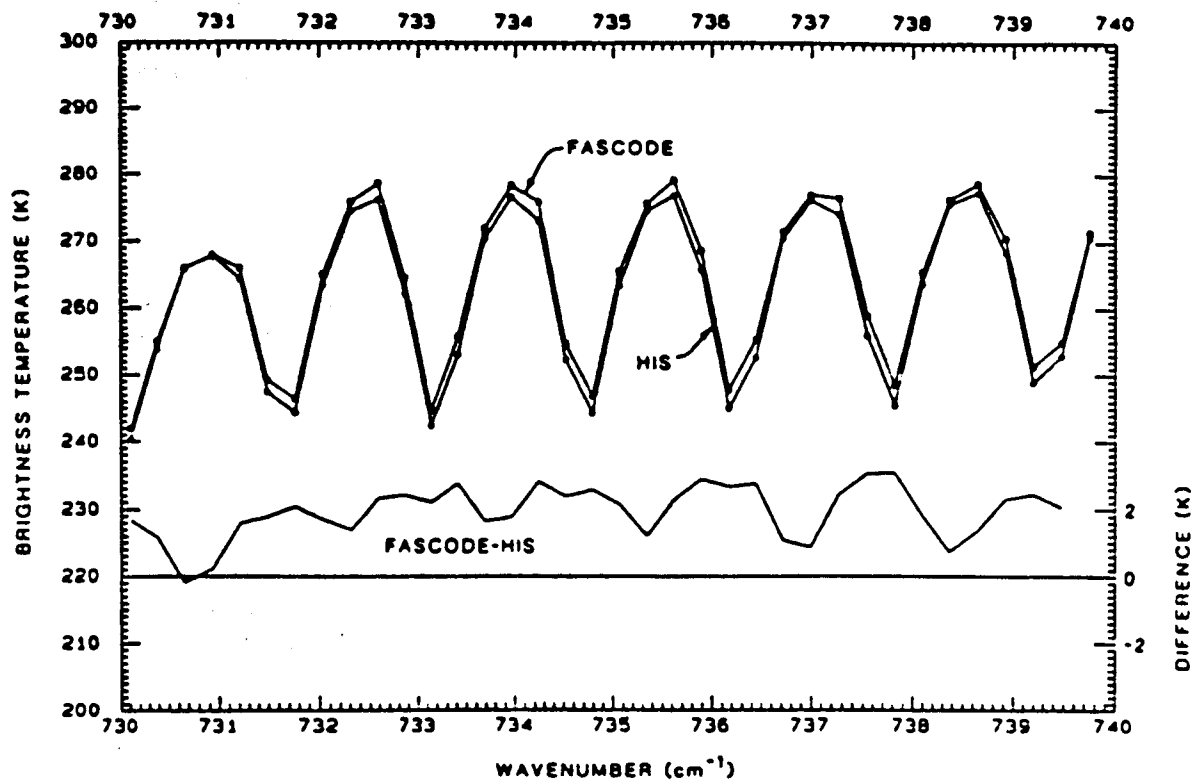

Figure 10. Closeup of HIS and FASCODE  $\text{CO}_2$  lines ( $0.5 \text{ cm}^{-1}$  resolution).

#### 4. CONCLUSIONS

The high radiometric precision and accuracy of the HIS aircraft instrument clearly demonstrate that there are no fundamental problems in achieving excellent radiometric calibration with an interferometer. In fact, the interferometer has the great asset that its wavenumber calibration and resolution function are defined by a small number of parameters which can easily be known accurately.

#### ACKNOWLEDGMENTS

The authors thank the members of the instrument team at the Space Science and Engineering Center, BOMEM, Inc., the Santa Barbara Research Center, and the University of Denver, whose care in fabricating and aligning the HIS instrument made accurate radiometric calibration realizable. Thanks also to Frank Murcray for many helpful discussions. The HIS program is jointly funded by NOAA contract NA-84-DGC-00095 and NASA contract NAS5-27608.

ORIGINAL PAGE IS  
OF POOR QUALITY

REFERENCES

- Clough, S.A., F.X.Kneizys, E.P.Shettle, G.P.Anderson, 1986: Atmospheric Radiance and Transmittance: FASCOD2, Sixth Conference on Atmospheric Radiation, American Meteorological Society, Boston, Massachusetts, 141.
- Hanel, R.A., B Schlachman, F.D. Clark, C.H. Prokesh, J.B. Taylor, W.M. Wilson, and L. Chaney, 1970: The Nimbus III Michelson Interferometer, Applied Optics, 9, 1767.
- Hanel, R.A., B. Schlachman, D. Rodgers, and D. Vanous, 1971: Nimbus 4 Michelson Interferometer, Applied Optics, 10, 1376.
- Hanel, R.A., B. Schlachman, E. Breihan, R. Bywaters, F. Chapman, M Rhodes, D. Rodgers and D. Vanous, 1972: Mariner 9 Michelson Interferometer, Applied Optics, 11, 2625.
- Hanel, R.A., D. Crosby, L. Herath, D. Vanous, D. Collins, H. Creswick, C. Harris, and D. Rhodes, 1980: Infrared Spectrometer for Voyager, Applied Optics, 19, 1391.
- LaPorte, D.D. and R. Howitt, 1982: Ambient Temperature Absolute Radiometry using Fourier Transform Spectrometers, SPIE, 364.
- Revercomb, H.E., D.D. LaPorte, W.L. Smith, H. Buijs, D.G. Murcray, F.J. Murcray, and L.A. Sromovsky, 1987: High-altitude Aircraft Measurements of Upwelling IR Radiance: Prelude to FTIR from Geosynchronous Satellite, Mikrochimica Acta, Springer-Verlag, Wien.
- Revercomb, H.E., H. Buijs, H.B. Howell, D.D. LaPorte, W.L. Smith, and L.A. Sromovsky, 1988: Radiometric Calibration of IR Fourier Transform Spectrometers: Solution to a Problem with the High-Resolution Interferometer Sounder (HIS), Applied Optics, in press.
- Rothman, L.S., R.R. Gamache, A. Goldman, L.R.Brown, R.A. Toth, H.M. Pickett, R.L. Poynter, J.-M. Flaud, C. Camy-Peryret, A. Barbe, N. Husson, C.P. Rinsland, and M.A.H. Smith, 1987: The HITRAN Database: 1986 Edition, Applied Optics, 26, 4058.
- Smith, W.L., H.E. Revercomb, H.B. Howell, and H.M. Woolf, 1983: HIS - A Satellite Instrument to Observe Temperature and Moisture Profiles with High Vertical Resolution, Fifth Conference on Atmospheric Radiation, American Meteorological Society, Boston, Mass.
- Smith, W.L., H.E. Revercomb, H.B. Howell, and H. M. Woolf, 1984: Recent Advances in Satellite Remote Sounding, International Radiation Symposium '84: Current Problems in Atmospheric Radiation, Edited by Giorgio Fiocco, A. Deepak Publishing, Hampton, Virginia, p.388.
- Smith, W.L., H.E. Revercomb, H.M. Woolf, H.B. Howell, D.D. LaPorte, and K. Kageyama, 1987a: Improved Geostationary Satellite Soundings for the Mesoscale Weather Analysis/Forecast Operations, Proc. Symp. Mesoscale Analysis and Forecasting, Vancouver, Canada, 17-19 August.
- Smith, W.L., H.M. Woolf, H.B. Howell, H.-L. Huang and H.E. Revercomb, 1987b: The Simultaneous Retrieval of Atmospheric Temperature and Water Vapor Profiles - Applications to Measurements with the High spectral Resolution Interferometer Sounder (HIS), this issue.

Ref 3. "Radiometric Calibration of IR Fourier Transform Spectrometers: Solution to a Problem with the High Resolution Interferometer Sounder", H.E. Revercomb, H. Buijs, H.B. Howell, D.D. LaPorte, W.L. Smith, and L.A. Sromovsky, Applied Optics, 27, 3210-3218, 1988.