

N89 - 17304

**AEROTHERMAL MODELING PROGRAM - PHASE II* ELEMENT B:
FLOW INTERACTION EXPERIMENT**

M. Nikjooy, H.C. Mongia, S.N.B. Murthy[†], and J.P. Sullivan[†]
Allison Gas Turbine Division
General Motors Corporation
Indianapolis, Indiana

NASA has instituted an extensive effort to improve the design process and data base for the hot section components of gas turbine engines. As part of this program, the purpose of Element B is to establish a benchmark quality data set that consists of measurements of the interaction of circular jets with swirling flow. Such flows are typical of those that occur in the primary zone of modern annular combustion liners. In addition to the detailed experimental effort, extensive computations of the swirling flows are to be compared with the measurements for the purpose of assessing the accuracy of current physical models used to predict such flows.

The Allison program for Element B has five major tasks:

1. Experimental Configuration
2. Modeling
3. Measurements
4. Results and Analysis
5. Model Improvement

EXPERIMENTAL CONFIGURATION

The flow to be investigated in the experiments consists of jets flowing into a confined swirling flow. The test section is a rectangular cross-section (381mm X 76.2mm) and extends to 10 duct heights (762mm) downstream from the headplate. A layout for the test section geometry is shown in Figure 1. The test section is constructed of glass and plexiglass to facilitate optical access for the Laser Doppler Velocimeter (LDV). Fluid enters the duct through five swirlers located at one end and through small jets located in the top and bottom. Experiments are done with both air and water as the flowing medium. The test section has been fabricated in such a way that two geometries could be investigated simultaneously--one using air for LDV measurements, and the other using water for flow visualization. The detailed test matrix for the Flow Interaction Program is given in Figure 2 and the corresponding flow configurations are shown in Figure 3. The configuration changes are made in both the air and water rigs with interchangeable upper and lower plates.

*Work done under NASA Contract NAS3-24350.

†Purdue University.

The variables to be investigated during this program are the following:

- o degree of swirl
- o distance of jets from the swirlers
- o ratio of mass flow through the jets to mass flow through the swirlers
- o jet locations with respect to the swirlers and each other

In all the measurements in air, the bulk velocity of the primary zone jets and of the fluid passing through the swirlers will be adjusted to 91m/sec and 45m/sec, respectively. The water experiments will require much lower velocities in order to avoid cavitation.

MODELING

This task involved simulation of different flow configurations using the current turbulence model (K- ϵ) for a preliminary study of the flow fields. The main importance of the task has been in highlighting different flow regions in the flow field that would be taken into account during measurements so as to resolve these regions of steep velocity gradient. Each flow configuration was computed using a 35X25X25 grid that was uniform in the Y-Z plane and nonuniform along the X-direction. There were several reasons for not using advanced turbulence models. Firstly, these are only used to help select the experimental configurations. Secondly, the results were obtained with a relatively coarse grid. Since these calculations are not grid independent, there is an excessive amount of numerical diffusion, thus obscuring the advantages offered by advanced models. The predicted results were qualitatively reasonable and the interaction of the jets and swirling flow was clearly seen.

MEASUREMENTS

An objective of the jet-swirl interaction experiments is to create a data base of benchmark quality on the fluid dynamic phenomena that occur in the primary zone of an annular gas turbine combustion chamber. The experiments include comprehensive measurements made at many points throughout the flow and completely document all boundary conditions. To be directly relevant to combustion design, the basic configuration of swirlers, jets, and flow channel should be as close as possible to modern gas turbine configurations while at the same time permitting the flow conditions to be stable, repeatable, and easily controllable. Each of the flows in the test matrix will be investigated with flow visualization techniques to establish flow characteristics and define regions of interest for conducting detailed single-point measurements. For the flow configuration identified in Task 1, measurements will be made to obtain the following:

- o detailed wall static pressure distribution
- o flow visualization
- o mean velocity and Reynolds stress components
- o fluctuating and mean concentration measurements
- o probability functions of velocity and concentration

Velocity measurements are made with a two-color, two-component LDV system which is mounted on a computer-controlled table that along with computer control of the field lens allows movement of the probe volume in three dimensions. The

data acquisition system consists of TSI counter type processors interfaced to a DEC 11/23 computer. The hardware interface contains a resettable 10-MHZ clock for measuring the time of arrival of a valid LDV signal. The simultaneous arrival of signals from the two components is determined in software by requiring that the respective clock signals are within 1-microsecond of each other. The DEC 11/23 also controls the X-Y-Z position of the probe volume through a stepper motor controller. The three beam optical arrangement allows measurements to be made close to a wall. By rotating the optics package about the optical axis, measurements near the end wall, top wall and bottom wall are possible.

RESULTS AND ANALYSIS

Measurements of velocity and concentration will be analyzed to determine the probability density function and auto- and cross-correlations.

The velocity distributions measured in the case of two on-line jets per swirler located at one duct height (3.0 in.) downstream of the swirler exit (Configuration A) for different axial locations are shown in Figures 4 through 7. These axial locations are at $x = 1.0, 1.5, 2.0, 2.5, 3.5, 4.5, 6.$ in. from the swirler exit. The measurements are presented at different lateral locations (6.0 in.-7.4 in.). Here the strong swirling flow is clearly evident and the extent of the swirl can be seen clearly. The flow goes through some radical changes in the first duct height, after this flow profiles remain rather constant with minor decay of the magnitude of the velocities. The comparisons between the measurements and the calculations will be presented in the meeting.

MODEL IMPROVEMENT

Due to limited success with the standard K- ϵ model and its modifications, work must be continued in improving advanced turbulence and scalar transport models. Turbulent closure of the mean flow equations is obtained by adopting a non-equilibrium and an equilibrium model for the Reynolds stresses using different pressure-strain models (Reference 1). In addition, performance of a high and low Reynolds number model using Reynolds-stress closures is investigated. As for the turbulent scalar flux calculations, two different models are presented (Reference 2). One solves the algebraic equations for the scalar fluxes, while the other employs the transport equations for their respective scalar fluxes. The accuracy of the model is determined by comparing the results with measurements.

REFERENCES

1. Nikjooy, M. and So, R. M. C., "On the Modeling of Non-Reactive and Reactive Turbulent Combustor Flows," NASA CR-4041, 1987.
2. Nikjooy, M. and So, R.M.C., "On The Modeling of Scalar and Mass Transport in Turbulent Combustor Flows", 5th Int. Conf. of Numerical Methods of Thermal Problems, Montreal, Canada, June 29-July 3, 1987; also submitted to the Int. J. Numerical Methods in Engineering.

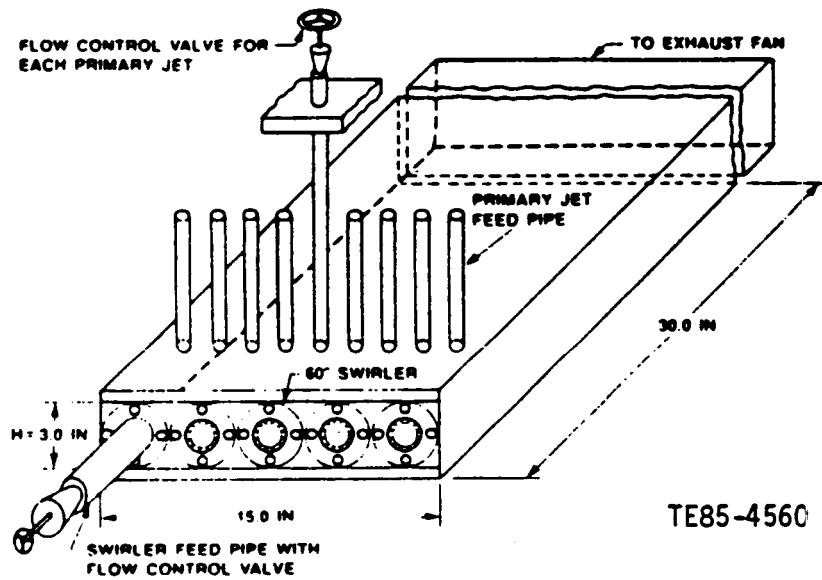

Figure 1. Test section geometry.

Test No.	Configuration	ξ_j/H	X_j/H	M_j/M_s	Tracer	Jets/swirler
1	BC1	-	-	-	No	-
2	BC2	-	-	-	No	-
3	A	1.0	0.5	0.75	No	2
4	B	1.0	0.5	0.75	No	2
5	C	1.0	0.5	0.75	No	2
6	D	1.0	0.5	0.75	No	2
7	E	0.5	0.5	1.50	No	4
8	F	0.5	0.5	1.50	No	4
9	A	1.0	1.0	0.75	No	2
10	B	1.0	1.0	0.75	No	2
11	E	0.5	1.0	1.50	No	4
12	F	0.5	1.0	1.50	No	4
13	A	1.0	0.5	1.50	No	2
14	A	1.0	0.5	0.75	Yes	2
15	B	1.0	0.5	0.75	Yes	2
16	E	0.5	0.5	1.50	Yes	4
17	F	0.5	0.5	1.50	Yes	4

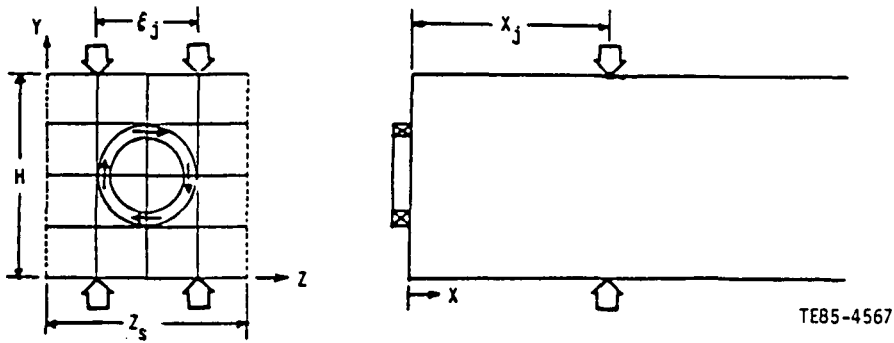

Figure 2. Test matrix.

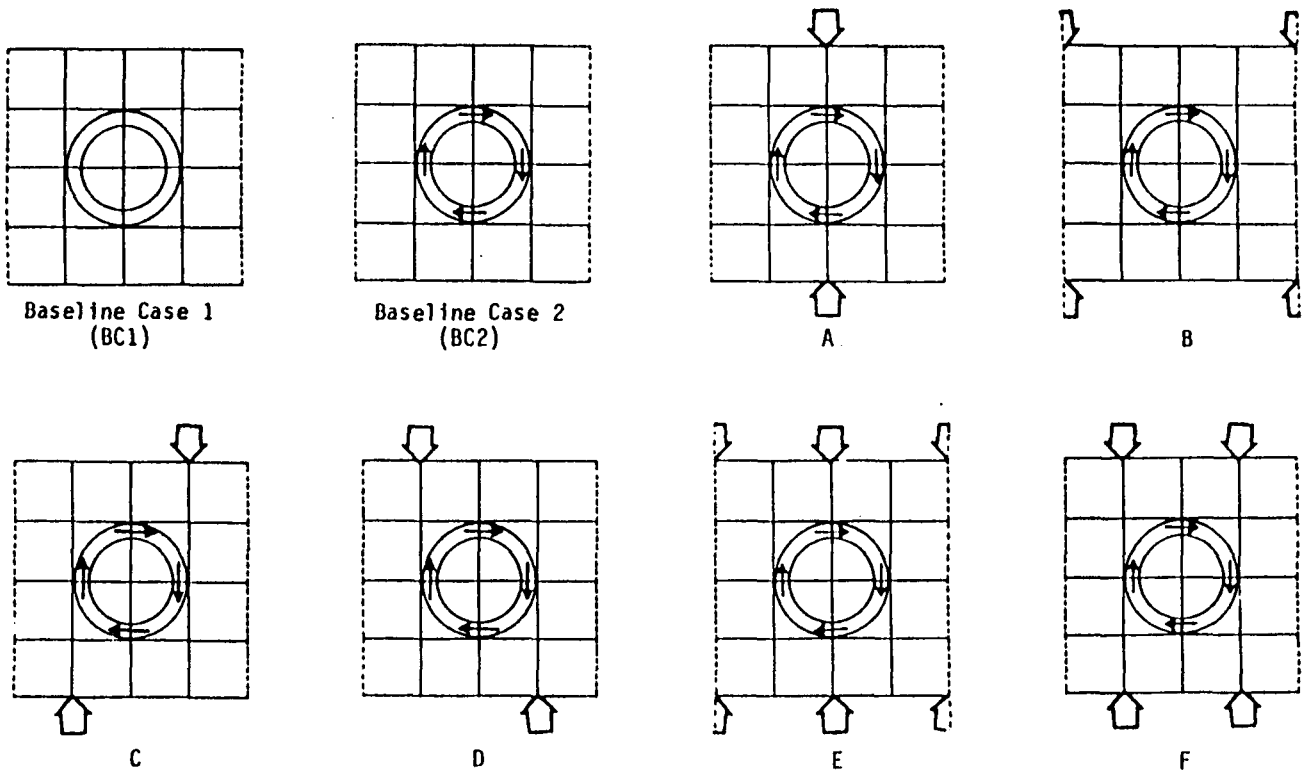
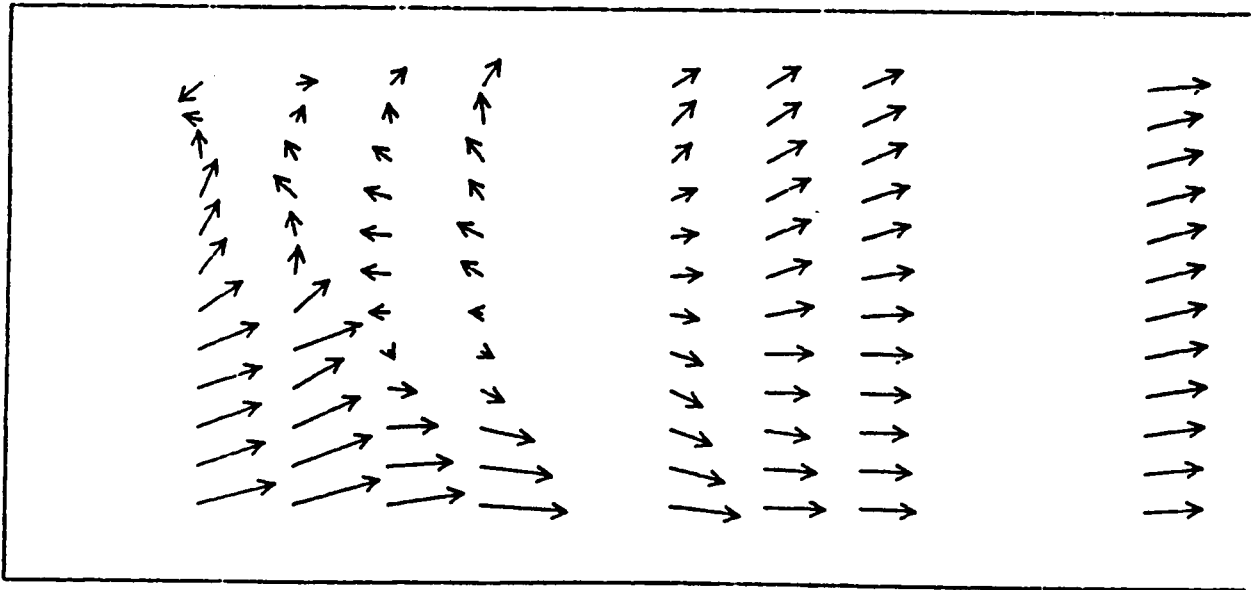

Figure 3. Basic flow configuration.

Z = 6.0



Z = 6.2

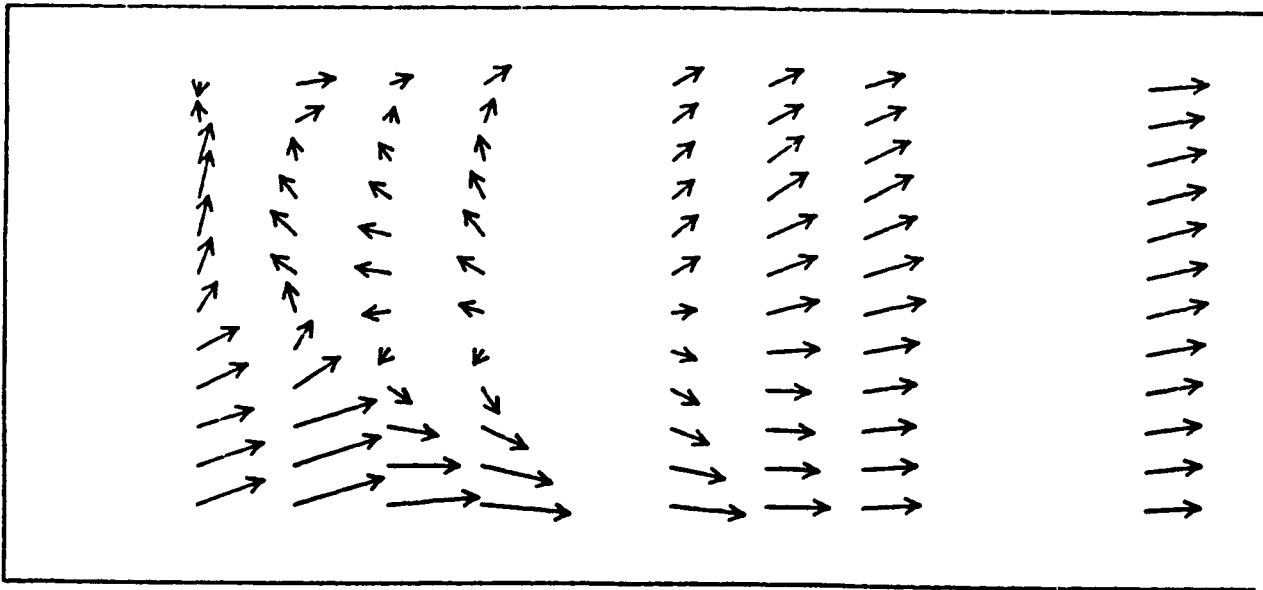
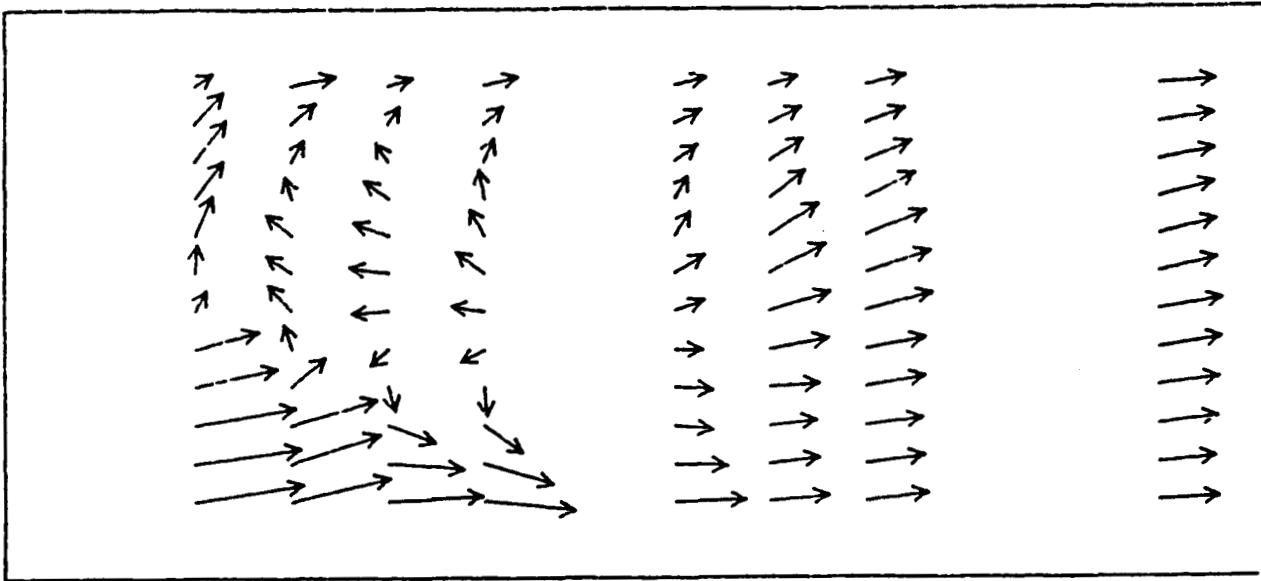

Figure 4. Longitudinal velocity vector plots for configuration with doubled primary jet flow.

Z = 6.4



Z = 6.6

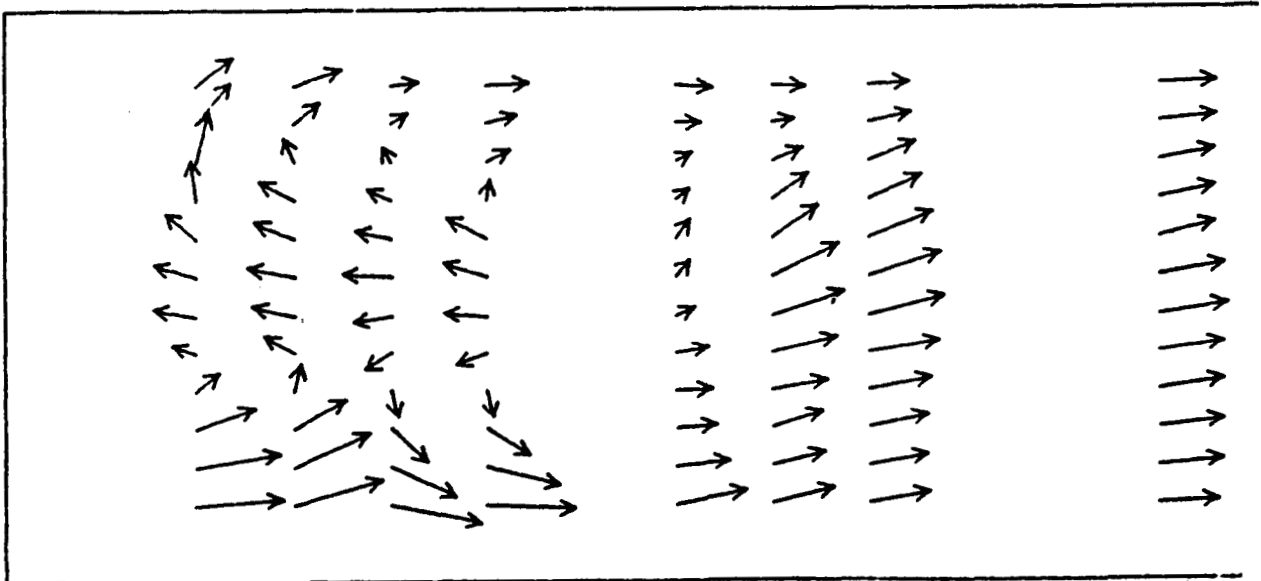
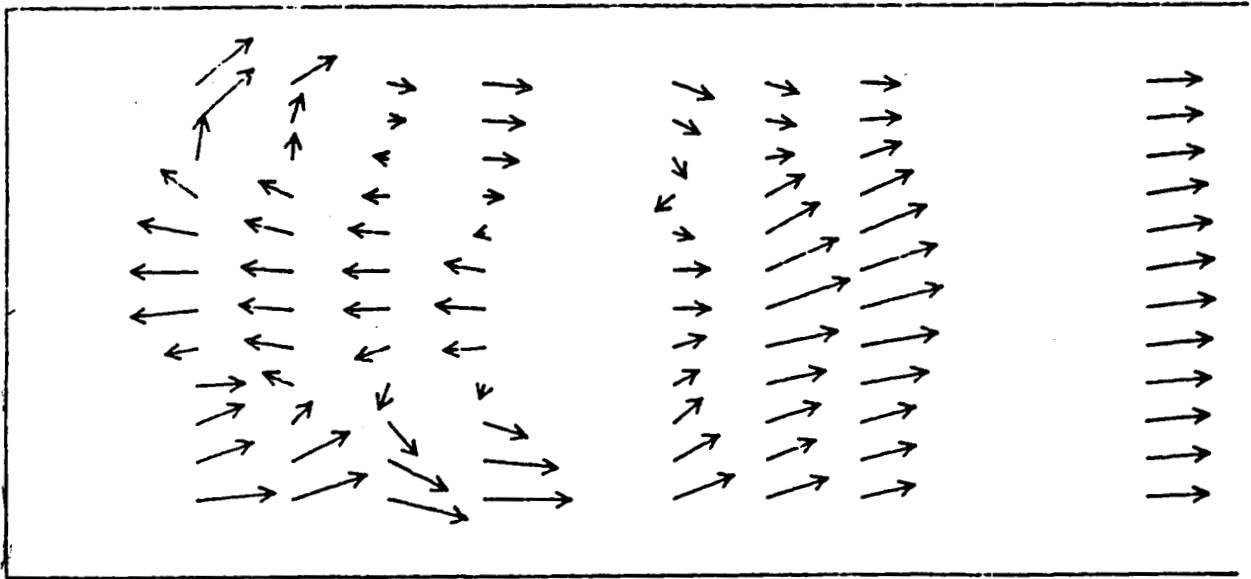

Figure 5. Longitudinal velocity vector plots for configuration with doubled primary jet flow.

Z = 6.8



Z = 7.0

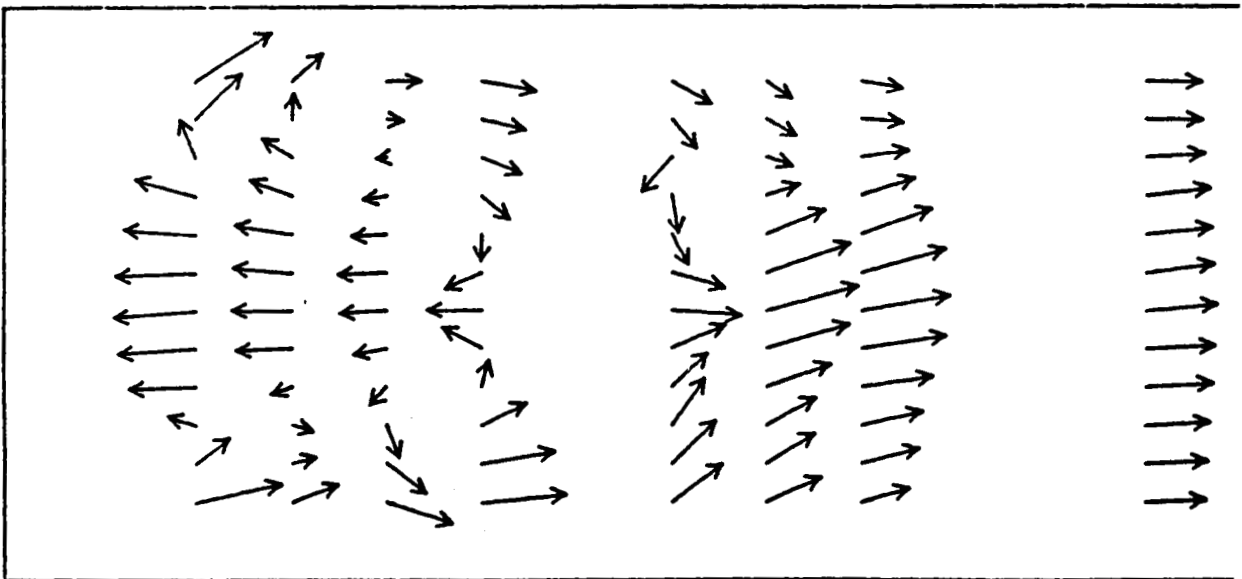
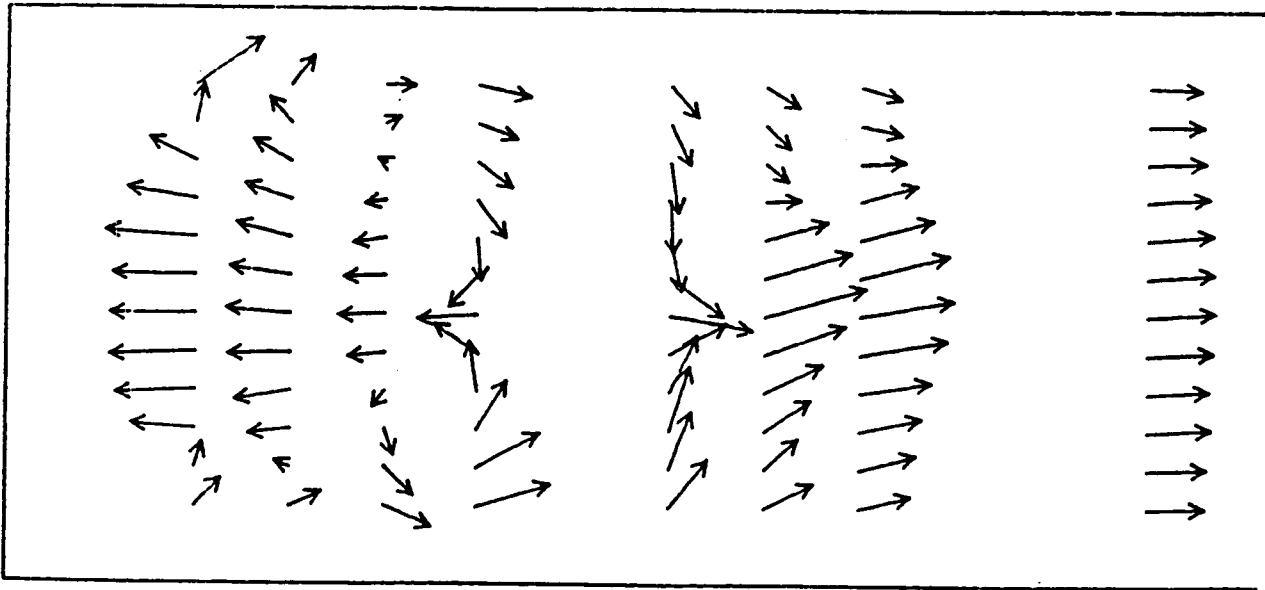

Figure 6. Longitudinal velocity vector plots for configuration with doubled primary jet flow.

Z = 7.2



Z = 7.4

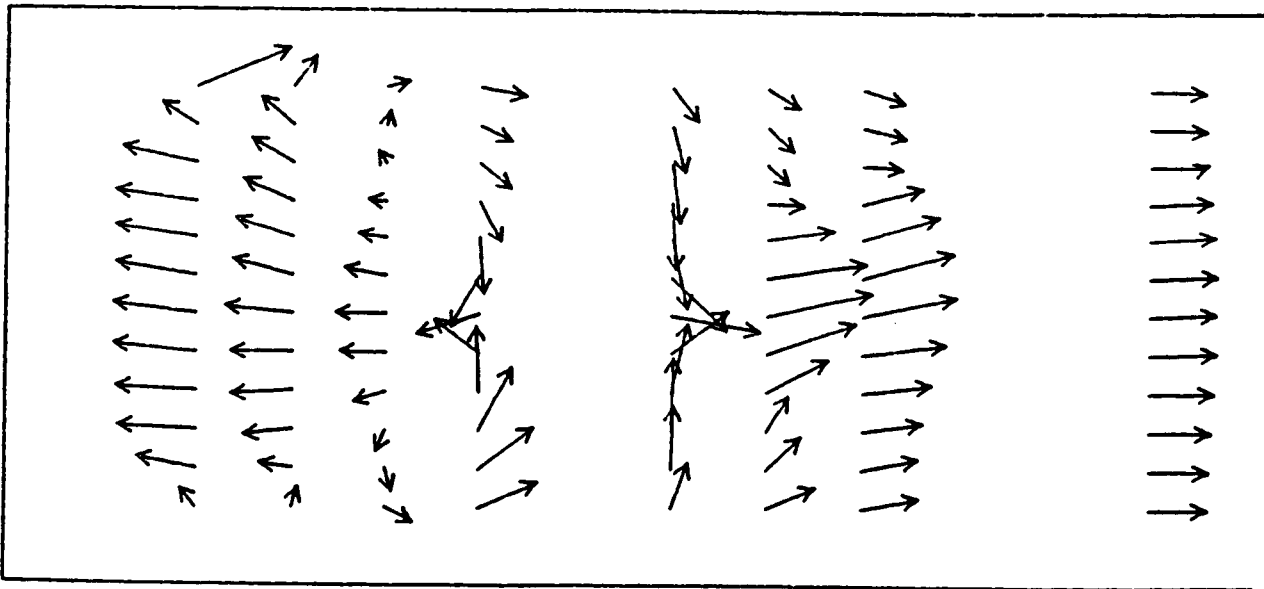

Figure 7. Longitudinal velocity vector plots for configuration with doubled primary jet flow.