Helicopter Hub Fairing and Pylon Interference Drag

D. R. Graham, D. Y. Sung, L. A. Young,
A. W. Louie, and R. H. Stroub

(NASA-TM-101052) HELICOPTER HUB FAIRING AND
PYLON INTERFERENCE DRAG (NASA) 191 p
CSCD 01A

N89-18416

Unclas
G3/02 0192815

January 1989



National Aeronautics and
Space Administration

Helicopter Hub Fairing and Pylon Interference Drag

D. R. Graham, Ames Research Center, Moffett Field, California

D. Y. Sung, Sterling Federal Systems, Inc., Palo Alto, California

L. A. Young, A. W. Louie, and R. H. Stroub, Ames Research Center, Moffett Field, California

January 1989

NASA

National Aeronautics and
Space Administration

Ames Research Center
Moffett Field, California 94035

TABLE OF CONTENTS

Page

SUMMARY	1
1. INTRODUCTION	1
2. DESCRIPTION OF TEST APPARATUS AND DATA ACQUISITION	2
2.1 Experimental Setups	2
2.2 Data Acquisition	2
2.3 Data Corrections	3
3. DESCRIPTION OF TESTED CONFIGURATIONS	4
3.1 Pylon Fairings	4
3.2 Hub Fairings	4
3.3 Pylon/Hub Fairing Gap	4
3.4 Blade Shank Integration	5
3.5 Inclined Shaft Configurations	6
3.6 Coaxial Rotor Configurations	6
4. FLOW VISUALIZATION	6
4.1 Oil Flow	6
4.2 Laser Sheet	6
4.3 Tufting Flow	7
5. INTERFERENCE DRAG ACCOUNTING METHODOLOGY	7
6. RESULTS	8
6.1 Hub Fairings	8
6.2 Pylons	9
6.3 Hub Fairing and Pylon Mutual Interference	10
6.4 Pylon/Hub Fairing Gap	10
6.5 Blade Shank Integration	11
6.6 Inclined Shaft Configurations	11
6.7 Coaxial Rotor Configurations	11
7. CONCLUDING REMARKS	11
REFERENCES	13
APPENDIX A – HUB DRAG REDUCTION TEST II DATA SUMMARY	15
APPENDIX B – FAIRING CONTOUR EQUATIONS	127
APPENDIX C – SHAFT FAIRING DESIGNATION	129
APPENDIX D – TEST LOG LEGEND AND TEST LOG	131
FIGURES	147

PRECEDING PAGE BLANK NOT FILMED

HELICOPTER HUB FAIRING AND PYLON INTERFERENCE DRAG

D. R. Graham, D. Y. Sung,¹ L. A. Young, A. W. Louie, and R. H. Stroub

Ames Research Center

SUMMARY

A wind tunnel test was conducted to study the aerodynamics of helicopter hub and pylon fairings. The test was conducted in the 7- by 10- Foot Subsonic Wind Tunnel (Number 2) at Ames Research Center using a 1/5-scale XH-59A fuselage model. The primary focus of the test was on the rotor hub fairing and pylon mutual interference drag. Parametric studies of pylon and hub fairing geometry were also conducted. This report presents the major findings of the test as well as tabulated force and moment data, flow visualization photographs, and graphical presentations of the drag data. The test results indicate that substantial drag reduction can be attained through the use of a cambered hub fairing with circular arc upper surface and flat lower surface. Furthermore, a considerable portion of the overall drag reduction is attributed to the reduction in the hub-on-pylon interference drag. It is also observed that the lower surface curvature of the fairing has a strong influence on the hub fairing and on pylon interference drag. However, the drag reduction benefit that was obtained by using the cambered hub fairing with a flat lower surface was adversely affected by the clearance between the hub fairing and the pylon.

1. INTRODUCTION

The fuel savings to be accrued from reduction of helicopter parasite drag has stimulated many research efforts (refs. 1-6). In particular, the incremental drag caused by the main rotor hub and the associated shaft and pylon accounts for a substantial portion of the total parasite drag: approximately 20-30% of total drag for a single rotor helicopter (refs. 2 and 3). Considering that parasite drag represents 40-50% of the total power requirements of a single rotor helicopter (ref. 2), it can be deduced that the drag of the hub and pylon represents roughly 10% of the total power required.

Given the relative importance of hub and pylon drag, a research program was initiated at NASA Ames Research Center to investigate hub fairing designs that can achieve substantial hub/pylon drag reduction. The wind tunnel test reported here was part of this ongoing research program. The key purpose of the test was to study the aerodynamic interactions between the hub fairing and the pylon. Drag data of various hub fairing and pylon designs were obtained. In addition to the quantitative data, qualitative data utilizing several flow visualization techniques were acquired to aid our understanding of the aerodynamic interactions between a helicopter hub fairing and pylon.

The major objectives of this test were: i) to study the hub fairing and pylon mutual interference drag, and ii) to conduct parametric studies of different hub fairing and pylon designs.

¹Sterling Federal Systems, Inc., Palo Alto, CA.

The wind tunnel test used a 1/5-scale model of the XH-59A fuselage. The hub and pylon fairing assemblies were mounted on the fuselage. The rotor shaft and hub fairing were nonrotating hardware. Additionally, part of the test was devoted to the study of isolated hub fairing drag. Data were composed of drag, lift, side force, yawing moment, rolling moment, and pitching moment. Three different flow visualization techniques—tufting, oil flow, and laser sheet—were used to acquire the qualitative data.

This report contains all the aerodynamic loads data and graphical presentations of selected portions of the drag data, as well as the flow visualization data. Findings based on the test results are presented. Test procedures and configurations are described, and data reliability is also discussed.

2. DESCRIPTION OF TEST APPARATUS AND DATA ACQUISITION

2.1 Experimental Setups

Two different experimental setups were used in the test. The first setup involved the use of a 1/5-scale XH-59A fuselage which was sting-mounted on its side. The hub and pylon fairings were mounted at the centerline of the rotor shaft on the top of the fuselage. The dimensions of the model and the sting are given in figures 1(a) and 1(b), and a model installation photograph is provided in figure 1(d). The model was placed approximately at the centerline of the tunnel, and it was side-mounted so that model angle of attack was controlled by yawing the tunnel turntable. All hub fairings tested were nonrotating hardware.

The second setup consisted of various isolated hub fairings mounted on a smaller sting. The isolated hub fairing again was situated approximately at the centerline of the tunnel. The test configuration and the dimensions of the sting are shown in figure 1(c). A sting with a small diameter was used in order to minimize aerodynamic interference between the hub fairing and the sting. The isolated hub fairing drag would be used in the breakdown of total incremental hub drag into various components of interference and isolated body drag.

2.2 Data Acquisition

For each test configuration, six component forces and moment data were measured by the wind tunnel external balance. These data were corrected for sting and weight tares. Data were recorded for a range of dynamic pressures and model angles of attack. For the XH-59A installation, dynamic pressures tested were 1915 Pa (40 lb/ft²), 2873 Pa (60 lb/ft²), and 3830 Pa (80 lb/ft²). For each of these dynamic pressures, data were obtained at an angle of attack of 0°.

Additionally, at a dynamic pressure of 3830 Pa (80 lb/ft²), an angle of attack sweep from -8° to 2° was typically performed, usually in increments of 2°. For the isolated hub fairing runs, data were taken only at 1915 Pa (40 lb/ft²) because of sting deflection limitations. Angle of attack sweeps were performed from -3° to 1° in increments of 1°. Appendix A tabulates all force and moment data and run conditions.

2.3 Data Corrections

2.3.1 Sting tares— All forces and moments were corrected for the sting aerodynamic loads. The sting tare for drag was 0.0575 m^2 (0.6187 ft) at $q = 3830 \text{ Pa}$ (80 lb/ft²), which typically amounted to 68% of total measured drag or 0.0850 m^2 (0.9146 ft). The interference effect between the fuselage and the sting should remain essentially constant for various pylon/hub fairing configurations, and was assumed to be small.

2.3.2 Weight tares— The data were corrected for the effects of changes in the center of gravity location as a function of angle of attack. Since the fuselage model was mounted on its side, only the yawing and rolling moment data were affected by the weight tares. Because the differences in weight between various pylon/hub configurations were negligible, the weight tare corrections determined for the H10, S10 configuration were used for all configurations.

2.3.3 Other corrections— Because the main objective of the test was to study the flow fields and relative drag level of different hub fairing and pylon configurations, no attempt was made to correct for the tunnel buoyancy, solid blockage, and wake blockage effects (ref. 7). These tunnel effects were assumed to be insensitive to the changes of hub fairing/pylon configurations, and thus should not have any impact on the consistency of the data.

2.3.4 Accuracy of the tunnel balance and dynamic pressure— The tunnel balance was checked by using static loads. The accuracy of the balance was measured to be $\pm 0.89 \text{ N}$ for the drag force and $\pm 3.34 \text{ N}$ for the lift and side forces. Therefore, for a typical fuselage + pylon + fairing drag measured, $D/q = 0.085 \text{ m}^2$ (0.9146 ft) at $q = 3830 \text{ Pa}$ (80 lb/ft²), the balance accuracy amounted to 0.3% in drag data uncertainty.

The accuracy of the dynamic pressure reading was estimated to be $\pm 20 \text{ Pa}$ (0.4 lb/ft²) at $q = 3830 \text{ Pa}$ (80 lb/ft²). This leads to a possible error of 0.5% in D/q data.

2.3.5 Reynolds number effect— Problems relating to Reynolds number effect (scale effect) on the drag measurements of helicopter models (high drag body) were well documented (ref. 8). Test data reported here also exhibited a dependence on the Reynolds number based on fuselage diameter (fig. 2). Because of the scope of the test, Reynolds number effect on the drag data will not be discussed in the report, and data presented in the later sections were taken at $Re = 2.21 \times 10^6$.

2.3.6 Data repeatability— When repeated data points were taken on the same day, they fell within the resolution of the wind tunnel balance. However, when the same configuration was repeated a week later, the repeated data did not fall within an acceptable range of uncertainty.

The data were bracketed within the vertical uncertainty bars in all the figures presented in the report. The inability to achieve acceptable data repeatability was attributed to the tunnel balance, which was observed to "drift" over time.

Although the data scatter is a concern, it should be emphasized that the measured drag trends and relative drag levels were demonstrated to be fairly consistent. Above all, because of the inherent problem with the scale effect (dependence of data on the Reynolds number), the purpose of the test was not to acquire data that could be used to predict actual flight performance of the helicopter configuration tested, but to study the aerodynamics of various hub fairings.

3. DESCRIPTION OF TESTED CONFIGURATIONS

One of the objectives of this test was to evaluate the change in drag due to variations in pylon and hub fairing geometry. Equations of the cross sections of the pylon and hub fairing were established with arbitrary coefficients which were later determined by appropriately chosen geometric conditions. A general description of the hub and pylon fairing cross sections is given in appendix B.

3.1 Pylon Fairings

Four pylon fairing geometry parameters were investigated. The first parametric sweep was to examine the effect of changes in the location of maximum thickness. All other parameters were held constant. Cross sections of the fairings tested are shown in figure 3. The values of all geometric parameters for these pylon fairings are given in appendix C. All pylon fairings had a maximum thickness of 0.1651 m (6.5 in.). For these runs, pylon height was 0.1778 m (7 in.). Each fairing is identified by an alphanumeric designation.

Changes in pylon fairing trailing edge slope, thickness ratio, and camber were the subjects of the second, third, and fourth parametric investigations. The cross sections of the fairings tested in each parametric sweep are shown in figures 4, 5, and 6, respectively.

Most pylon fairings were tested with two different hub fairings—a circular arc upper surface with flat lower surface hub fairing (H50), and a circular arc symmetrical hub fairing (H10). These two hub fairings were chosen as the baseline fairings for two reasons: H50 was a low drag configuration identified in a previous test; H10 was a conventional fairing shape (ref. 5).

3.2 Hub Fairings

Parametric study of the hub fairing geometry was an important part of the test. All hub fairings were tested with the baseline pylon (S40—very similar to a NACA 0034 cross section). Additionally, some hub fairings were tested with another low drag pylon (S80), so that the effects of pylon fairing geometry on the load trends of the hub fairing parametric sweeps could be studied.

The effect of changes in the camber of hub fairings with the same thickness ratio was the subject of one investigation. Figure 7 shows the cross sections of the fairings that were tested. Another investigation of camber and hub fairing thickness ratio was conducted for flat lower surface fairings. The changes in camber and thickness ratio were accomplished in two different ways: for one set of fairings, the diameter was held constant while thickness was varied (fig. 8); for a second set of fairings, thickness was held constant and the diameter was varied (fig. 9).

The other two hub fairing geometry sweeps involved changes in the basic fairing shape. One parametric investigation was directed at determining the effect of changing the upper surface profile of flat lower surface fairings. The tested cross sections are shown in figure 10. The second sweep was for symmetrical fairings with similar profile changes. Figure 11 shows the shapes tested.

3.3 Pylon/Hub Fairing Gap

For actual helicopter operation, blade flapping and blade droop at low rotor speeds may necessitate spacing between the hub and pylon fairings. Figure 12 shows a photograph of a typical configuration as well as a sketch giving the dimension points of interest (g and h). For this test, the hub/pylon gap width (g) was varied from 0 m to 0.1016 m (4 in.) with hub height (h) of 0.1778 m (7 in.).

For most tested configurations, a hole large enough to accommodate the swashplate was present in the top of the pylon fairing. For some configurations, however, test runs were made with a simulated rainshield such as is found on some helicopters. These runs are noted in the run log which is found in appendix D.

Additional test runs were devoted to a series of attempted remedies to the additional drag resulting from the introduction of the hub/pylon gap. These fixes included a pylon fairing fence configuration, a large thickness ratio hub fairing, and a dual-component hub fairing. Figure 13 shows these configurations. Hub height for all of these runs was 0.1778 m (7 in.) and gap height was 0.0254 m (1 in.).

Related to the gap height studies above, a limited investigation was conducted into the effect of matching the lower surface contour of the hub fairing with the upper surface contour of the pylon fairing. The highly cambered hub fairings (H50, H60) were tested with a circular-arc cross-section pylon fairing (S200) that was configured with either a flat or contoured (to match the H60 lower surface contour) upper surface as shown in figure 14. Gap height (measured at shaft centerline) was 0.0254 m (1 in.) for all runs, and hub height was 0.1524 m (6 in.). All runs were made with a simulated rainshield.

Though not specifically related to the study of hub/pylon gap effects, an additional set of test runs was done with the H60, S200 configuration (0.1524 m (0.5000 ft) hub height, 0.0254 m (0.0833 ft) gap height) to investigate the effect of trailing edge and leading edge extensions to the pylon fairing. The extensions were triangular wedges. Figure 15 shows a typical configuration. The fairing configuration was first tested with one of the two trailing edge extensions. The extensions were 0.1067 m (4.2 in.) and 0.2311 m (9.1 in.) in length. The most effective of these two configurations, the one with the 0.2311 extension, was then tested with each of two leading edge extensions. These extensions were 0.0889 m (3.5 in.) and 0.1753 m (6.9 in.) in length.

3.4 Blade Shank Integration

The incorporation of blade shanks into the hub fairing was another attempt to increase the realism of the modeling. For this test, a four-bladed rotor was modeled (fig. 16(a)). Two different sets of blade shanks were used. The first set (denoted as blade shank set #1) has a rectangular cross-sectional shape with rounded corners (fig. 16(b)). The second set (denoted as blade shank set #2) had an oval cross section, and was significantly larger than blade shank set #1.

For blade shank set #1, the following information also applies: assuming a full-scale rotor radius of 7.62 m (25.00 ft), and noting that the model is 1/5-scale, the flap hinge offset is 0.04 R and the shanks were truncated at 0.107 R. Also, blade pitch and flapping were set for each test run as a function of blade azimuthal position, model angle of attack, and dynamic pressure. (Note that operating dynamic pressure was set to 3830 Pa (80 lb/ft²), and model angle of attack was selected to be -5°.) Given that hub rotation was not possible in this test, azimuthal indexing of the blades was performed instead. Each configuration was tested at four azimuthal locations: 0°, 22.5°, 45°, or 67.5°. A test run was also performed with the gaps around the shanks filled in to simulate an elastomeric shutter arrangement that might be used to fill this hole. This was done for the cambered hub fairing only.

Some testing was performed for blade shank set #2. For these blade shanks, pitch angles were maintained at 0° and flapping angle was held constant at a small value. Blades were indexed azimuthally at 0° and 45°. Flap hinge offset was again 0.04 R, and the shanks were truncated at 0.169 R when using the same assumptions as for blade shank set #1.

3.5 Inclined Shaft Configurations

Some helicopters have a rotor shaft that is not perpendicular to the longitudinal axis of the fuselage. This type of arrangement will obviously give rise to a hub/pylon fairing interface that is different from the more common configuration studied previously. Several test runs were done to investigate the effectiveness of various hub fairing concepts when applied to the inclined shaft configuration.

The baseline configuration consisted of an H50 hub fairing with an S40 pylon fairing and a shaft-forward inclination of 5° , as shown in figure 17. Drag reduction concepts tested included a rectangular planform pylon with a hub/pylon gap and a dual-component hub fairing.

3.6 Coaxial Rotor Configurations

A limited amount of test time was devoted to coaxial rotor configurations. The focus of these runs was on the effect of upper hub fairing camber on model drag. Each coaxial configuration tested consisted of a 0.0762 m (3 in.) section of S40 pylon fairing next to the fuselage, a circular-arc, cambered lower hub fairing (H50) on top of that, a 0.1270 m (5 in.) section of a 0.2642 m (10.4 in.) chord, 0.0711 m (2.8 in.) thick airfoil section intermediate shaft fairing, and a circular-arc, cambered upper hub fairing. Upper hub fairings with cambers of 9%, 12%, 15%, and 17% were tested. In addition, one run was made with a circular-arc symmetrical hub fairing (H80). Figure 18 shows a typical configuration.

4. FLOW VISUALIZATION

In addition to the quantitative data, a large body of qualitative flow visualization data was acquired. These data consisted of photographs of flow patterns using oil flow, tuft, and laser sheet visualization techniques.

4.1 Oil Flow

For several configurations, an oil/paint mixture was applied to the model, and photographs of the steady-state flow pattern were taken at 1915 Pa (40 lb/ft²) and 3830 Pa (80 lb/ft²) and at 0° angle of attack. Figure 19 shows a representative set of pictures.

4.2 Laser Sheet

A laser sheet was used to visualize the formation of the tip vortices that were shed from the hub fairing. The laser sheet was oriented nearly perpendicular to the flow at different longitudinal stations. Figures 20, 21(a), and 21(b) are a representative set.

The operating dynamic pressure for these runs was 1915 Pa (40 lb/ft²). An argon ion laser was used with a 4 W output. The light sheet was formed through a cylindrical lens. The precipitate formed by mixing hydrous ammonia with sulfur dioxide was used to seed the flow. It should be noted that because of the fixed position of the laser, it was not practical to maintain a strictly vertical sheet at different longitudinal positions.

4.3 Tufting flow

Tufts were used to trace out on-body streamlines and to identify areas of reverse flow. Consequently, regions of separated flow could be approximated. Such information is a valuable supplement to the drag data. Therefore, tufting photographs were compiled, and arranged according to the designation number of the hub and pylon fairing (figs. 22-51). Each plate shows the side view of the model.

For most configurations, the model was tufted in the areas of interest: the top of the hub fairing; the side of the pylon fairing; and the fuselage surface in front, on the side, and aft of the hub and pylon fairing. All photographs were taken at dynamic pressure of 3830 Pa (80 lb/ft²) and at 0° angle of attack. It should be noted that tuft runs were separated from drag data runs.

5. INTERFERENCE DRAG ACCOUNTING METHODOLOGY

In order to break down the overall drag into component drag and interference drag, a number of hub fairings were tested as isolated bodies. The run log (app. D) contains a complete listing of the isolated hub fairings that were tested. Note that the sting and hub fairing mutual interference effects were not accounted in this test. Moreover, the test conditions of the isolated test were different from those of the 1/5-scale test. Considering the limitations imposed by these two test setups, the interference drag calculated later in the report were at best first-order approximations.

To aid our analytical study of the drag data, the following notations will be used in this discussion. With the general notations:

- CD_x (X body isolated drag)
- CD_{x/y} (X body on Y body interference drag)
- CD_{y/x} (Y body on X body interference drag)
- CD_{xy} (mutual interference drag of the X body + Y body)
= CD_{x/y} + CD_{y/x}

and specifically,

$$\begin{aligned} CD'_I &= CD'_{fp} + CD'_{ph} + CD'_{fh} \\ &= CD'_{f/p} + CD'_{p/f} + CD'_{p/h} + CD'_{h/p} + CD'_{f/h} + CD'_{h/f} \\ &= CD'_t - CD'_f - CD'_p - CD'_h \end{aligned}$$

where

- CD_I total mutual interference drag between fuselage, pylon, and hub fairing
- CD_t total drag of the fuselage + pylon + hub fairing

and

- CD_f isolated fuselage drag
- CD_h isolated hub fairing drag
- CD_p isolated pylon drag

CD_{fh}	mutual interference drag of the fuselage + hub fairing
CD_{fp}	mutual interference drag of the fuselage + pylon
CD_{ph}	mutual interference drag of the pylon + hub fairing
$CD_{f/h}$	fuselage-on-hub interference drag
$CD_{f/p}$	fuselage-on-eylon interference drag
$CD_{h/f}$	hub-on-fuselage interference drag
$CD_{h/p}$	hub-on-eylon interference drag
$CD_{p/f}$	eylon-on-fuselage interference drag
$CD_{p/h}$	eylon-on-hub interference drag

6. RESULTS

This section presents major results as well as theoretical analyses of the test data.

6.1 Hub Fairings

Parametric studies of different hub fairing design parameters were conducted to examine effects of hub fairing geometry on drag. The profiles of the hub fairing cross sections are of key interest. Hub fairing profiles with different camber, diameter, and thickness ratio were studied in the test.

6.1.1 Camber— Hub fairings with high camber were observed to be low drag configurations (refs. 5 and 6). Thus a parametric study of the camber effect on drag was conducted. Hub fairings with the same diameter and thickness distribution (but different camber) were tested with the S40 and S80 pylons, and the drag trends are shown in figure 52. The data indicate that increases in hub fairing camber result in drag reduction. The tufting photos of H20, H30, H40, H50, and H60 fairings with S40 pylons (figs. 32, 34, 35, 39, and 48) show that the region of separated flow at the upper aft portion of the pylon surface diminished with the camber, while the flow on the upper surface of the fairing remained attached. Therefore, the reduction in the hub-on-eylon interference drag, $CD_{h/p}$, appears to make a significant contribution to the overall drag reduction.

For the H20-H60 fairing series, the skin friction drag is roughly the same, while the profile drag is higher for the more cambered fairing. The drag data in figure 53 also shows that the component drag of the hub fairing, CD_h , increases with the camber, while the interference drag displays the opposite trend. Therefore, it seems reasonable to set forth the induction that high cambered fairings yield low mutual interference drag, and that CD_{hp} is much more important than CD_h in determining the overall drag level.

Note that in figure 52 the drag trend of the H20-H60 fairing series with S80 as the baseline pylon behaves somehow differently. Change in camber has little impact on drag except when camber is at 9.0%, where there is an abrupt drop in drag. One possible explanation for this trend is as follows. Because of a very strong adverse pressure gradient (a consequence of high surface gradient) on the pressure recovery side between 0.2c (chord length) and 0.7c, the S80 pylon is likely to have an unstable boundary layer, which is sensitive to interference effect and prone to flow separation. Thus we may suggest that hub fairings with low camber tend to cause the unstable boundary layer on the pylon to separate, while fairings with camber close to 9% tend to have a minimal interference effect on the flow over the pylon.

6.1.2 Maximum thickness ratio— The circular-arc upper surface and flat lower surface the hub fairing was used to investigate the sensitivity of drag to change in the hub fairing thickness ratio (camber varied accordingly). S40 was used as the baseline pylon. It is observed that with either design constraint (hub diameter or thickness) fixed, the overall drag increases with maximum thickness ratio and camber (fig. 54). Moreover, these fairings with flat lower surface, in general, appear to have lower drag relative to the H20-H40 hub fairings studied in the last section.

The above observation, however, counters the generalization made previously that higher camber yields lower drag (seemingly evident in fig. 52). This leads to an alternative explanation that the lower surface curvature of the fairing, instead of the fairing camber, is the actual cause of the drag reduction. In other words, flat lower surface fairings may have a cleaner aerodynamic interaction with the pylon compared to fairings with positive curvature on the lower surface.

6.1.3 Surface curvature— The study of hub fairing shapes with symmetrical cross sections (zero camber) and the S40 pylon substantiates the above finding. (fig. 55) The fairing cross section was varied from a nearly rectangular shape to one with a reflexed surface. The data again indicate that the fairing with a nearly flat lower surface (H150) has notably lower drag than the other shapes. Moreover, the drag of each of the hub fairings tested as an isolated body is approximately the same except that of the H10 hub fairing (fig. 56).

The effect on drag of upper surface curvature of hub fairings with a flat lower surface is shown in figure 57. As the fairing cross section changes gradually from a nearly rectangular shape to a highly reflexed one, the drag exhibits an optimum low for the circular-arc upper surface fairing. Based on the same figure, one may also conclude that the drag is not sensitive to the fine adjustments of the upper surface profile. This implies that a range of upper surface profiles is acceptable for a low drag fairing design.

6.2 Pylons

Parametric studies of different pylon design parameters were also conducted to examine effects of pylon geometry on drag. Pylon profiles with location of maximum thickness, trailing edge slope, maximum thickness ratio, and camber were studied in the test.

6.2.1 Location of maximum thickness— In the case of the S40 to S110 pylons with H50 as the baseline hub fairing, figure 58 indicates that drag increases as the location of maximum thickness (l) moves rearward, particularly after $l = 0.45$. The tufting photos of these configurations also confirm such a trend: the flow separation is more extensive at the aft portion of the S100, S60, and S50 pylons (figs. 44, 41, and 40, respectively) compared to that of the S80, S110 and S40 pylons (figs. 43, 45, and 39). The pylon-alone configurations follow a similar trend.

When using H10 as the baseline hub fairing, the data exhibited a drag bucket which appears to bottom at $l = 0.30$ to 0.40 .

6.2.2 Trailing edge slope— Drag increases with the pylon fairing trailing edge slope, the S10-S40 pylon series, with both the H10 and the H50 hub fairing (fig. 59). However, the increase is more significant in the case with the H50 fairing. Drag trends of the pylon-alone configurations again follow those of the H50.

6.2.3 Maximum thickness ratio— Figure 60 shows that the drag remains relatively constant with respect to the increase in pylon maximum thickness ratio for the S40, S140, and S150 pylons, with the H50 fairing or in the pylon-alone case. For the configurations with the H10 fairing, there is a gradual ascent in drag with the thickness ratio.

6.2.4 Camber- The pylon fairing camber apparently had little impact on drag when the H50 fairing was used (fig. 61).

6.3 Hub Fairing and Pylon Mutual Interference

Interference drag arises because of the aerodynamic interactions between the hub fairing and the pylon. These aerodynamic interactions include potential flow interaction, three dimensional boundary layer interaction, and vortex interaction.

Keys (ref. 2) reported that the mutual interference drag between hub and pylon could amount to 35% of the total hub drag, and the hub-on-ylon interference drag ($CD_{h/p}$) generally would dominate the pylon-on-hub interference drag ($CD_{p/h}$). In some cases, $CD_{h/p}$ was five times the magnitude of $CD_{p/h}$. The flow visualization data of the tunnel test reported here also confirm such findings.

The tufting photos of the H10-S40, H20-S40, and H50-S40 configurations (figs. 23, 32, and 39, respectively) reveal that the flow field around the pylon is altered significantly because of the presence of different hub fairings. The drag data also reflect the significance of the mutual interference effect. This leads to a conclusion that deserves much emphasis: the aerodynamic interactions between the hub fairing and pylon are of fundamental importance, and determine the effectiveness of different hub fairing designs.

6.4 Pylon/Hub Fairing Gap

While holding the pylon height (h) constant, the effect on drag of introducing a gap (g) between the hub fairing and pylon is presented in figure 62 (see fig.12 for the geometry). The clearance between the hub fairing and pylon appears to negate a substantial portion of the drag reduction benefits achieved by using the cambered fairing (H50). The drag penalty due to the hub-ylon clearance is less severe in the case of the high drag configuration (H10).

The effect of covering the hole in the upper surface of the pylon fairing with a rainshield is shown in figures 63 and 64. For these runs, the hub height was 0.1524 m (0.5000 ft). These figures indicate that drag may be reduced considerably by using a rainshield if a hub/ylon fairing gap cannot be eliminated.

Several attempts were made to remedy the fairing gap problem (fig. 65). As can be seen from the figure, the best solution for this problem seems to be "filling in" the gap with additional hub fairing. In other words, a larger thickness ratio hub fairing should be used to close the hub/ylon gap.

It was hypothesized that increases in the camber of hub fairings resulted in drag benefits. Therefore, for configurations with a hub/ylon fairing gap, a study was done on the effect of matching the upper surface pylon fairing contour to the lower surface hub fairing contour for highly cambered hub fairings. Figure 66 presents the results of these test runs. No significant effect resulting from matching fairing contours is observed.

The effect on drag of the addition of leading edge and trailing edge extensions to the pylon fairing is shown in figure 67. No significant reduction was obtained for the extension lengths tested. However, the data suggest that incorporation of extensions longer than those tested may be beneficial.

6.5 Blade Shank Integration

Test runs with blade shanks incorporated into the hub fairing were conducted (fig. 68). H2 and H4 represent a symmetrical and a cambered hub fairing, respectively, with blade shanks attached (refer to fig. 16). Note that for each blade shank configuration, the presented data are averaged over various azimuthal index positions. As can be seen from the data for set #1, the addition of blade shanks removes some of the drag reduction benefit that the cambered hub fairing (H4) has over the symmetrical hub fairing (H2).

Additionally, it can be seen that with the larger blade shanks (set # 2) which extend even farther in the radial direction, the drag reduction benefits attained by using the cambered hub fairing were cut down significantly.

6.6 Inclined Shaft Configurations

The drag of various fairing configurations designed to accommodate an inclined shaft is shown in figure 69. As seen in the figure, the dual-component hub fairing configuration (H54-S40, see fig.17) provides the best performance.

6.7 Coaxial Rotor Configurations

The drag of various coaxial rotor configurations (fig. 18) is shown in figures 70 and 71. In figure 70, it can be seen that drag increases with the camber of the upper hub fairing with flat lower surface. This result is the same as that of the corresponding single rotor case. In figure 71, a symmetrical top hub fairing is compared to the cambered fairings. The symmetrical top hub fairing configuration has significantly higher drag than that of the cambered ones with the same thickness ratio. Again, as for the case of a single rotor, it is demonstrated that the curvature of the lower surface is more important in drag reduction than change in camber.

7. CONCLUDING REMARKS

The results of a 1/5-scale wind tunnel test indicated that substantial drag reduction can be attained through the use of a hub fairing with circular-arc upper surface and flat lower surface. The following conclusions are based on examination of the drag and flow visualization data:

- a. Aerodynamic interactions between the fairing and pylon are the fundamental factors which determine the drag level of seemingly similar hub fairing designs.
- b. The reduction in the hub-on-ylon interference drag resulting from the use of a hub fairing contributes significantly to the overall drag reduction. Hub fairing design thus should be coupled with the pylon and upper aft fuselage design in order to achieve optimal results.
- c. It is observed that the lower surface curvature of the fairing has a strong influence on the hub fairing and pylon interference drag. Hub fairings with a flat lower surface yield minimal interference drag.
- d. For the hub fairing with a flat lower surface, the drag is not sensitive to fine adjustments of the upper surface cross section.

- e. The clearance between hub fairing and pylon has a detrimental effect on the drag reduction attained by using the H50 low-drag hub fairing.
- f. The incorporation of blade shanks negates part of the drag reduction benefit of using the flat lower surface hub fairing.

REFERENCES

1. Special report presented to American Helicopter Society, 31st Annual National Forum, by the Ad Hoc Committee on Rotorcraft Drag, Washington D.C., 21 May 1975.
2. Keys, C. N.; and Rosenstein, H. J.: Summary of Rotor Hub Drag Data. NASA CR-152080, Mar. 1978.
3. Sheehy, T. W.: A Method for Predicting Helicopter Hub Drag. USAAMRDL TR-75-48, Jan. 1976.
4. Felker, F. F.: An Experimental Investigation of Hub Drag on the XH-59A. Proceedings of the AIAA 3rd Applied Aerodynamics Conference, Oct. 1985.
5. Young, L. A.; and Graham, D. R.: Experimental Investigation of Rotorcraft Hub and Shaft Fairing Drag. Proceedings of the AIAA 4th Applied Aerodynamics Conference, June 1986.
6. Young, L. A.; Graham, D. R.; Stroub, R. H.; and Louie, A. W.: Reduction of Hub and Pylon Fairing Drag. Proceedings of the 43rd Annual Forum and Technology Display of the American Helicopter Society, May 1987.
7. Rae, W. H.; and Pope, A.: Low-Speed Wind Tunnel Testing. John Wiley and Sons, 1984.
8. Logan, A. H.; Prouty, R. W.; and Clark, D. R.: Wind Tunnel Test of Large- and Small-Scale Rotor Hubs and Pylons. Applied Technology Laboratory, U.S. Army Research and Technology Laboratories, AVRADCOM TR-80-D-21, Apr. 1981.
9. Abbott, I. H.; and Von Doenhoff, A. E.: Theory of Wing Sections. Dover, 1959.

APPENDIX A
HUB DRAG REDUCTION TEST II DATA SUMMARY

NASA Ames 7- by 10-Foot Wind Tunnel
August 1987

All force and moment data as well as run conditions are presented in the tabulations on the following pages.

PRECEDING PAGE BLANK NOT FILMED

Run# 8

Dynamic Pressure (N/m ²)	Angle of Attack (deg)	D/q (m ²)	L/q (m ²)	SF/q (m ²)	PM/q (m ³)	YM/q (m ³)	RM/q (m ³)
1910.4	0.0	0.0787	0.0140	0.0361	-0.0368	-0.0360	-0.0099
2877.6	0.0	0.0804	0.0127	0.0352	-0.0359	-0.0370	-0.0084
3840.0	-8.0	0.0802	0.0038	0.0203	-0.0604	-0.0351	-0.0031
3820.8	-6.0	0.0806	0.0051	0.0210	-0.0533	-0.0347	-0.0034
3816.0	-4.0	0.0811	0.0055	0.0249	-0.0450	-0.0351	-0.0037
3820.8	-2.0	0.0813	0.0091	0.0302	-0.0412	-0.0363	-0.0050
3840.0	0.0	0.0816	0.0088	0.0367	-0.0315	-0.0376	-0.0087
3835.2	2.0	0.0844	0.0143	0.0420	-0.0302	-0.0432	-0.0112
3796.9	-8.0	0.0801	0.0029	0.0216	-0.0581	-0.0336	-0.0041
3825.6	0.0	0.0821	0.0080	0.0363	-0.0299	-0.0391	-0.0095
3840.0	2.0	0.0847	0.0125	0.0423	-0.0272	-0.0434	-0.0128

Run# 9

Dynamic Pressure (N/m ²)	Angle of Attack (deg)	D/q (m ²)	L/q (m ²)	SF/q (m ²)	PM/q (m ³)	YM/q (m ³)	RM/q (m ³)
1948.7	0.0	0.0760	0.0219	0.0292	-0.0300	-0.0325	-0.0110
2868.0	0.0	0.0774	0.0181	0.0302	-0.0246	-0.0354	-0.0114
3897.4	-8.0	0.0775	0.0053	0.0185	-0.0575	-0.0320	-0.0022
3868.7	-6.0	0.0778	0.0026	0.0204	-0.0401	-0.0300	-0.0049
3887.9	-4.0	0.0783	0.0072	0.0221	-0.0340	-0.0304	-0.0043
3878.3	-2.0	0.0785	0.0117	0.0253	-0.0287	-0.0330	-0.0050
3859.1	0.0	0.0798	0.0138	0.0284	-0.0200	-0.0359	-0.0094
3863.9	2.0	0.0814	0.0185	0.0317	-0.0128	-0.0397	-0.0133
3859.1	-8.0	0.0770	0.0061	0.0181	-0.0565	-0.0301	-0.0021
3844.8	-6.0	0.0774	0.0047	0.0202	-0.0427	-0.0297	-0.0046
3835.2	-4.0	0.0781	0.0082	0.0224	-0.0359	-0.0311	-0.0039
3835.2	-2.0	0.0785	0.0131	0.0273	-0.0308	-0.0327	-0.0052
3835.2	0.0	0.0796	0.0160	0.0303	-0.0237	-0.0345	-0.0085
3820.8	2.0	0.0817	0.0205	0.0332	-0.0180	-0.0404	-0.0136

D/q = drag area, L/q = lift to dynamic pressure ratio, SF/q = side force to dynamic pressure ratio,
 PM/q = pitch moment to dynamic pressure ratio, YM/q = yaw moment to dynamic pressure ratio,
 RM/q = roll moment to dynamic pressure ratio.

Run# 10

Dynamic Pressure (N/m ²)	Angle of Attack (deg)	D/q (m ²)	L/q (m ²)	SF/q (m ²)	PM/q (m ³)	YM/q (m ³)	RM/q (m ³)
1924.8	0.0	0.0652	-0.030	0.0109	-0.0248	-0.0365	-0.0100
2858.4	0.0	0.0666	-0.062	0.0106	-0.0201	-0.0374	-0.0108
3820.8	-8.0	0.0703	-0.056	0.0111	-0.0583	-0.0350	-0.0060
3840.0	-6.0	0.0683	-0.078	0.0085	-0.0454	-0.0351	-0.0047
3840.0	-4.0	0.0688	-0.100	0.0092	-0.0340	-0.0356	-0.0046
3840.0	-2.0	0.0682	-0.096	0.0102	-0.0255	-0.0361	-0.0053
3820.8	0.0	0.0681	-0.098	0.0111	-0.0172	-0.0376	-0.0087
3806.5	2.0	0.0713	-0.0012	0.0137	-0.0223	-0.0423	-0.0089

Run# 11

Dynamic Pressure (N/m ²)	Angle of Attack (deg)	D/q (m ²)	L/q (m ²)	SF/q (m ²)	PM/q (m ³)	YM/q (m ³)	RM/q (m ³)
1905.6	0.0	0.0696	0.0140	0.0184	-0.0290	-0.0348	-0.0091
2848.9	0.0	0.0714	0.0126	0.0190	-0.0293	-0.0383	-0.0075
3830.4	-8.0	0.0737	-0.020	0.0165	-0.0605	-0.0365	-0.0004
3830.4	-6.0	0.0728	-0.022	0.0161	-0.0458	-0.0354	-0.0008
3811.2	-4.0	0.0726	0.0013	0.0183	-0.0380	-0.0356	-0.0009
3816.0	-2.0	0.0723	0.0063	0.0189	-0.0326	-0.0370	-0.0025
3777.7	0.0	0.0728	0.0114	0.0215	-0.0272	-0.0391	-0.0047
3796.9	2.0	0.0747	0.0182	0.0230	-0.0248	-0.0426	-0.0083

Run# 13

Dynamic Pressure (N/m ²)	Angle of Attack (deg)	D/q (m ²)	L/q (m ²)	SF/q (m ²)	PM/q (m ³)	YM/q (m ³)	RM/q (m ³)
1915.2	0.0	0.0790	0.0139	0.0153	-0.0309	-0.0341	-0.0084
1915.2	0.0	0.0783	0.0149	0.0177	-0.0316	-0.0335	-0.0091
2868.0	0.0	0.0802	0.0119	0.0178	-0.0292	-0.0361	-0.0069
3835.2	0.0	0.0826	0.0101	0.0191	-0.0265	-0.0373	-0.0081
3849.6	-8.0	0.0803	0.0062	0.0162	-0.0608	-0.0341	-0.0054
3825.6	-6.0	0.0807	0.0027	0.0159	-0.0452	-0.0334	-0.0054
3820.8	-4.0	0.0814	0.0028	0.0164	-0.0365	-0.0345	-0.0059
3844.8	-2.0	0.0817	0.0053	0.0176	-0.0308	-0.0357	-0.0071
3844.8	0.0	0.0820	0.0102	0.0191	-0.0281	-0.0378	-0.0079
3820.8	2.0	0.0843	0.0153	0.0235	-0.0258	-0.0413	-0.0118

Run# 14

Dynamic Pressure (N/m ²)	Angle of Attack (deg)	D/q (m ²)	L/q (m ²)	SF/q (m ²)	PM/q (m ³)	YM/q (m ³)	RM/q (m ³)
1910.4	0.0	0.0887	0.0384	0.0019	-0.0383	-0.0342	-0.0058
2868.0	0.0	0.0904	0.0338	0.0031	-0.0332	-0.0350	-0.0051
3840.0	-8.0	0.0868	0.0147	0.0089	-0.0662	-0.0375	-0.0017
3830.4	-6.0	0.0871	0.0131	0.0073	-0.0503	-0.0365	-0.0024
3825.6	-4.0	0.0880	0.0152	0.0066	-0.0409	-0.0364	-0.0017
3811.2	-2.0	0.0896	0.0204	0.0077	-0.0347	-0.0365	-0.0028
3792.1	0.0	0.0901	0.0256	0.0059	-0.0316	-0.0381	-0.0033
3806.5	2.0	0.0952	0.0339	0.0138	-0.0280	-0.0409	-0.0069
3801.7	0.0	0.0930	0.0284	0.0122	-0.0308	-0.0374	-0.0076

Run# 15

Dynamic Pressure (N/m ²)	Angle of Attack (deg)	D/q (m ²)	L/q (m ²)	SF/q (m ²)	PM/q (m ³)	YM/q (m ³)	RM/q (m ³)
1915.2	0.0	0.0783	0.0102	0.0163	-0.0294	-0.0342	-0.0102
2896.7	0.0	0.0809	0.0126	0.0178	-0.0338	-0.0366	-0.0080
3844.8	-8.0	0.0816	0.0035	0.0128	-0.0593	-0.0340	-0.0007
3844.8	-8.0	0.0811	0.0023	0.0128	-0.0481	-0.0329	-0.0013
3835.2	-4.0	0.0813	0.0036	0.0135	-0.0408	-0.0333	-0.0011
3840.0	-2.0	0.0817	0.0058	0.0155	-0.0355	-0.0348	-0.0028
3820.8	0.0	0.0825	0.0099	0.0187	-0.0312	-0.0362	-0.0053
3816.0	2.0	0.0843	0.0143	0.0225	-0.0282	-0.0411	-0.0079

19 Run# 16

Dynamic Pressure (N/m ²)	Angle of Attack (deg)	D/q (m ²)	L/q (m ²)	SF/q (m ²)	PM/q (m ³)	YM/q (m ³)	RM/q (m ³)
1896.0	0.0	0.0706	0.0148	0.0310	-0.0304	-0.0337	-0.0097
2877.6	0.0	0.0727	0.0175	0.0326	-0.0352	-0.0361	-0.0076
3840.0	-8.0	0.0737	0.0027	0.0227	-0.0649	-0.0339	0.0022
3811.2	-8.0	0.0728	0.0047	0.0258	-0.0536	-0.0323	0.0017
3835.2	-4.0	0.0731	0.0059	0.0296	-0.0427	-0.0328	0.0000
3854.3	-2.0	0.0733	0.0106	0.0293	-0.0389	-0.0353	-0.0014
3854.3	0.0	0.0740	0.0155	0.0331	-0.0332	-0.0380	-0.0038
3854.3	2.0	0.0763	0.0193	0.0362	-0.0286	-0.0427	-0.0078
3873.5	0.0	0.0734	0.0157	0.0320	-0.0325	-0.0386	-0.0068

Run# 17

Dynamic Pressure (N/m ²)	Angle of Attack (deg)	D/q (m ²)	L/q (m ²)	SF/q (m ²)	PM/q (m ³)	YM/q (m ³)	RM/q (m ³)
1924.8	0.0	0.0772	0.0125	0.0102	-0.0328	-0.0334	-0.0102
2863.2	0.0	0.0800	0.0039	0.0106	-0.0211	-0.0370	-0.0104
3859.1	-8.0	0.0823	-0.062	0.0114	-0.0446	-0.0369	-0.0053
3859.1	-6.0	0.0817	-0.055	0.0099	-0.0366	-0.0367	-0.0047
3849.6	-4.0	0.0812	-0.012	0.0097	-0.0339	-0.0361	-0.0036
3835.2	-2.0	0.0813	0.0022	0.0118	-0.0299	-0.0362	-0.0041
3849.6	0.0	0.0820	0.0069	0.0122	-0.0272	-0.0367	-0.0063
3830.4	2.0	0.0837	0.0121	0.0131	-0.0257	-0.0406	-0.0090

Run# 18

Dynamic Pressure (N/m ²)	Angle of Attack (deg)	D/q (m ²)	L/q (m ²)	SF/q (m ²)	PM/q (m ³)	YM/q (m ³)	RM/q (m ³)
1905.6	0.0	0.0731	0.0205	0.0021	-0.0375	-0.0307	-0.0079
2872.8	0.0	0.0762	0.0110	0.0006	-0.0244	-0.0346	-0.0086
3863.9	-8.0	0.0782	-0.040	0.0029	-0.0538	-0.0387	-0.0029
3844.8	-6.0	0.0773	-0.019	0.0022	-0.0442	-0.0363	-0.0021
3840.0	-4.0	0.0771	0.0017	0.0005	-0.0373	-0.0359	-0.0021
3840.0	-2.0	0.0777	0.0080	0.0007	-0.0342	-0.0348	-0.0035
3820.8	0.0	0.0785	0.0140	-0.0012	-0.0320	-0.0361	-0.0044
3820.8	2.0	0.0813	0.0222	0.0019	-0.0326	-0.0387	-0.0075
3835.2	0.0	0.0790	0.0175	-0.0017	-0.0355	-0.0389	-0.0064

Run# 19

Dynamic Pressure (N/m ²)	Angle of Attack (deg)	D/q (m ²)	L/q (m ²)	SF/q (m ²)	PM/q (m ³)	YM/q (m ³)	RM/q (m ³)
1929.6	0.0	0.0779	0.0113	0.0258	-0.0307	-0.0349	-0.0112
2853.6	0.0	0.0803	0.0031	0.0271	-0.0193	-0.0361	-0.0122
3806.5	-8.0	0.0820	0.0014	0.0155	-0.0580	-0.0352	-0.0017
3825.6	-6.0	0.0809	0.0026	0.0180	-0.0488	-0.0338	-0.0018
3811.2	-4.0	0.0813	0.0021	0.0216	-0.0382	-0.0340	-0.0030
3859.1	-2.0	0.0824	0.0046	0.0233	-0.0327	-0.0362	-0.0037
3816.0	0.0	0.0824	0.0078	0.0263	-0.0283	-0.0388	-0.0059
3863.9	2.0	0.0839	0.0124	0.0289	-0.0261	-0.0418	-0.0080

Run# 20

Dynamic Pressure (N/m ²)	Angle of Attack (deg)	D/q (m ²)	L/q (m ²)	SF/q (m ²)	PM/q (m ³)	YM/q (m ³)	RM/q (m ³)
1915.2	0.0	0.0718	0.0156	0.0307	-0.0283	-0.0352	-0.0107
2906.3	0.0	0.0751	0.0133	0.0317	-0.0263	-0.0379	-0.0101
3863.9	-8.0	0.0763	0.0063	0.0207	-0.0694	-0.0354	0.0016
3849.6	-6.0	0.0755	0.0070	0.0242	-0.0558	-0.0338	0.0013
3854.3	-4.0	0.0754	0.0087	0.0297	-0.0443	-0.0344	0.0000
3849.6	-2.0	0.0761	0.0129	0.0315	-0.0384	-0.0361	-0.0018
3796.9	0.0	0.0776	0.0170	0.0319	-0.0328	-0.0400	-0.0044
3849.6	2.0	0.0790	0.0218	0.0327	-0.0294	-0.0442	-0.0078

Run# 21

Dynamic Pressure (N/m ²)	Angle of Attack (deg)	D/q (m ²)	L/q (m ²)	SF/q (m ²)	PM/q (m ³)	YM/q (m ³)	RM/q (m ³)
1905.6	0.0	0.0738	0.0203	0.0177	-0.0307	-0.0338	-0.0080
2901.5	0.0	0.0765	0.0152	0.0167	-0.0254	-0.0362	-0.0089
3859.1	-8.0	0.0788	0.0023	0.0103	-0.0606	-0.0373	-0.0015
3844.8	-6.0	0.0776	0.0071	0.0112	-0.0547	-0.0352	-0.0010
3835.2	-4.0	0.0776	0.0090	0.0166	-0.0441	-0.0330	-0.0016
3830.4	-2.0	0.0782	0.0131	0.0170	-0.0366	-0.0339	-0.0033
3820.8	0.0	0.0790	0.0173	0.0179	-0.0318	-0.0382	-0.0049
3840.0	2.0	0.0811	0.0227	0.0195	-0.0275	-0.0435	-0.0078

Run# 22

Dynamic Pressure (N/m ²)	Angle of Attack (deg)	D/q (m ²)	L/q (m ²)	SF/q (m ²)	PM/q (m ³)	YM/q (m ³)	RM/q (m ³)
1924.8	0.0	0.0781	0.0118	0.0196	-0.0321	-0.0348	-0.0087
2868.0	0.0	0.0811	0.0064	0.0209	-0.0246	-0.0381	-0.0089
3830.4	-8.0	0.0825	0.0030	0.0128	-0.0619	-0.0357	-0.0011
3796.9	-6.0	0.0817	0.0050	0.0151	-0.0539	-0.0340	-0.0011
3801.7	-4.0	0.0823	0.0055	0.0163	-0.0450	-0.0361	-0.0007
3859.1	-2.0	0.0828	0.0066	0.0195	-0.0374	-0.0364	-0.0029
3787.3	0.0	0.0835	0.0086	0.0222	-0.0306	-0.0391	-0.0060
3806.5	2.0	0.0848	0.0124	0.0228	-0.0270	-0.0428	-0.0085

Run# 23

Dynamic Pressure (N/m ²)	Angle of Attack (deg)	D/q (m ²)	L/q (m ²)	SF/q (m ²)	PM/q (m ³)	YM/q (m ³)	RM/q (m ³)
1896.0	0.0	0.0835	0.0183	-.0077	-0.0382	-0.0388	-0.0083
2877.6	0.0	0.0863	0.0124	-.0085	-0.0303	-0.0391	-0.0081
3825.6	-8.0	0.0863	0.0088	0.0024	-0.0629	-0.0436	-0.0004
3840.0	-6.0	0.0857	0.0073	-.0002	-0.0506	-0.0415	0.0007
3844.8	-4.0	0.0858	0.0076	-.0035	-0.0417	-0.0401	-0.0003
3835.2	-2.0	0.0868	0.0100	-.0055	-0.0364	-0.0400	-0.0019
3820.8	0.0	0.0875	0.0125	-.0088	-0.0312	-0.0405	-0.0040
3830.4	2.0	0.0899	0.0152	-.0099	-0.0267	-0.0428	-0.0068

Run# 24

Dynamic Pressure (N/m ²)	Angle of Attack (deg)	D/q (m ²)	L/q (m ²)	SF/q (m ²)	PM/q (m ³)	YM/q (m ³)	RM/q (m ³)
1920.0	0.0	0.0785	0.0246	0.0334	-0.0381	-0.0382	-0.0114
2829.7	0.0	0.0816	0.0173	0.0267	-0.0293	-0.0396	-0.0118
3859.1	0.0	0.0838	0.0175	0.0067	-0.0333	-0.0446	-0.0105
3830.4	-8.0	0.0823	0.0087	-.0027	-0.0685	-0.0486	0.0002
3830.4	-8.0	0.0820	0.0085	-.0007	-0.0699	-0.0469	-0.0010
3820.8	-6.0	0.0811	0.0112	-.0028	-0.0610	-0.0447	0.0004
3830.4	-4.0	0.0819	0.0142	-.0087	-0.0521	-0.0433	0.0003
3835.2	-2.0	0.0825	0.0157	-.0099	-0.0406	-0.0425	-0.0006
3811.2	0.0	0.0837	0.0193	-.0095	-0.0353	-0.0417	-0.0033
3792.1	2.0	0.0854	0.0242	-.0038	-0.0302	-0.0457	-0.0081

Run# 26

Dynamic Pressure (N/m ²)	Angle of Attack (deg)	D/q (m ²)	L/q (m ²)	SF/q (m ²)	PM/q (m ³)	YM/q (m ³)	RM/q (m ³)
1929.6	0.0	0.0717	0.0182	0.0203	-0.0375	-0.0340	-0.0063
2848.9	0.0	0.0735	0.0153	0.0214	-0.0360	-0.0359	-0.0065
3863.9	-8.0	0.0746	0.0052	0.0183	-0.0708	-0.0348	0.0027
3849.6	-6.0	0.0745	0.0059	0.0190	-0.0613	-0.0336	0.0008
3840.0	-4.0	0.0748	0.0067	0.0207	-0.0502	-0.0334	-0.0004
3820.8	-2.0	0.0751	0.0083	0.0204	-0.0402	-0.0348	-0.0018
3811.2	0.0	0.0761	0.0137	0.0195	-0.0367	-0.0380	-0.0038
3816.0	2.0	0.0784	0.0191	0.0231	-0.0321	-0.0418	-0.0079

Run# 27

Dynamic Pressure (N/m ²)	Angle of Attack (deg)	D/q (m ²)	L/q (m ²)	SF/q (m ²)	PM/q (m ³)	YM/q (m ³)	RM/q (m ³)
1934.4	0.0	0.0777	0.0154	0.0131	-0.0433	-0.0335	-0.0045
2877.6	0.0	0.0799	0.0097	0.0131	-0.0305	-0.0360	-0.0093
3863.9	-8.0	0.0802	0.0100	0.0115	-0.0700	-0.0372	0.0025
3849.6	-6.0	0.0804	0.0095	0.0102	-0.0594	-0.0365	0.0024
3835.2	-4.0	0.0810	0.0068	0.0110	-0.0466	-0.0359	0.0000
3816.0	-2.0	0.0812	0.0075	0.0118	-0.0380	-0.0362	-0.0021
3801.7	0.0	0.0821	0.0103	0.0143	-0.0326	-0.0388	-0.0043
3782.5	2.0	0.0841	0.0142	0.0169	-0.0289	-0.0425	-0.0082

Run# 28

Dynamic Pressure (N/m ²)	Angle of Attack (deg)	D/q (m ²)	L/q (m ²)	SF/q (m ²)	PM/q (m ³)	YM/q (m ³)	RM/q (m ³)
1924.8	0.0	0.0772	0.0136	0.0109	-0.0381	-0.0361	-0.0092
2892.0	0.0	0.0791	0.0102	0.0105	-0.0331	-0.0375	-0.0079
3868.7	-8.0	0.0784	0.0094	0.0095	-0.0727	-0.0379	0.0041
3863.9	-6.0	0.0786	0.0076	0.0094	-0.0589	-0.0368	0.0034
3840.0	-4.0	0.0796	0.0072	0.0094	-0.0491	-0.0368	0.0023
3830.4	-2.0	0.0799	0.0088	0.0096	-0.0427	-0.0372	-0.0001
3801.7	0.0	0.0807	0.0121	0.0117	-0.0368	-0.0396	-0.0032
3816.0	0.0	0.0808	0.0115	0.0108	-0.0365	-0.0397	-0.0027
3811.2	0.0	0.0806	0.0121	0.0109	-0.0373	-0.0402	-0.0021
3796.9	2.0	0.0821	0.0151	0.0124	-0.0327	-0.0423	-0.0061
3820.8	-2.0	0.0795	0.0087	0.0093	-0.0410	-0.0381	-0.0054

Run# 29

Dynamic Pressure (N/m ²)	Angle of Attack (deg)	D/q (m ²)	L/q (m ²)	SF/q (m ²)	PM/q (m ³)	YM/q (m ³)	RM/q (m ³)
1920.0	0.0	0.0716	0.0151	0.0144	-0.0388	-0.0347	-0.0071
2882.4	0.0	0.0741	0.0122	0.0185	-0.0344	-0.0375	-0.0074
3859.1	-8.0	0.0748	0.0038	0.0126	-0.0765	-0.0385	0.0044
3840.0	-6.0	0.0741	0.0036	0.0138	-0.0618	-0.0367	0.0033
3825.6	-4.0	0.0749	0.0049	0.0135	-0.0507	-0.0367	0.0024
3830.4	-2.0	0.0753	0.0081	0.0128	-0.0440	-0.0377	0.0000
3849.6	0.0	0.0763	0.0125	0.0178	-0.0376	-0.0402	-0.0027
3830.4	2.0	0.0787	0.0179	0.0258	-0.0336	-0.0440	-0.0072

Run# 30

Dynamic Pressure (N/m ²)	Angle of Attack (deg)	D/q (m ²)	L/q (m ²)	SF/q (m ²)	PM/q (m ³)	YM/q (m ³)	RM/q (m ³)
1924.8	0.0	0.0730	0.0180	0.0159	-0.0340	-0.0356	-0.0087
2853.6	0.0	0.0751	0.0170	0.0170	-0.0329	-0.0376	-0.0067
3840.0	-8.0	0.0752	0.0056	0.0132	-0.0695	-0.0365	0.0023
3859.1	-8.0	0.0754	0.0048	0.0131	-0.0690	-0.0360	0.0026
3859.1	-8.0	0.0754	0.0062	0.0133	-0.0718	-0.0369	0.0029
3859.1	-6.0	0.0748	0.0061	0.0127	-0.0568	-0.0360	0.0019
3816.0	-4.0	0.0752	0.0077	0.0143	-0.0476	-0.0358	0.0002
3811.2	-2.0	0.0761	0.0131	0.0167	-0.0400	-0.0373	-0.0013
3796.9	0.0	0.0772	0.0162	0.0180	-0.0330	-0.0391	-0.0043
3801.7	2.0	0.0794	0.0209	0.0234	-0.0272	-0.0433	-0.0090
3816.0	-2.0	0.0759	0.0128	0.0174	-0.0388	-0.0369	-0.0069

Run# 31

Dynamic Pressure (N/m ²)	Angle of Attack (deg)	D/q (m ²)	L/q (m ²)	SF/q (m ²)	PM/q (m ³)	YM/q (m ³)	RM/q (m ³)
1910.4	0.0	0.0801	0.0137	0.0121	-0.0354	-0.0356	-0.0108
2877.6	0.0	0.0819	0.0108	0.0124	-0.0330	-0.0375	-0.0089
3854.3	-8.0	0.0823	0.0090	0.0107	-0.0693	-0.0371	0.0012
3854.3	-6.0	0.0825	0.0061	0.0107	-0.0558	-0.0366	0.0004
3840.0	-4.0	0.0831	0.0054	0.0109	-0.0450	-0.0367	0.0012
3844.8	-2.0	0.0835	0.0074	0.0113	-0.0382	-0.0367	-0.0025
3835.2	0.0	0.0844	0.0107	0.0121	-0.0336	-0.0401	-0.0047
3792.1	2.0	0.0867	0.0141	0.0163	-0.0279	-0.0438	-0.0098
3820.8	-2.0	0.0835	0.0080	0.0123	-0.0371	-0.0379	-0.0077

Run# 32

Dynamic Pressure (N/m ²)	Angle of Attack (deg)	D/q (m ²)	L/q (m ²)	SF/q (m ²)	PM/q (m ³)	YM/q (m ³)	RM/q (m ³)
1891.3	0.0	0.0760	0.0134	0.0129	-0.0375	-0.0354	-0.0077
2868.0	0.0	0.0788	0.0109	0.0141	-0.0345	-0.0369	-0.0069
3820.8	-8.0	0.0793	0.0095	0.0123	-0.0721	-0.0366	-0.0001
3820.8	-6.0	0.0790	0.0068	0.0127	-0.0584	-0.0363	-0.0005
3820.8	-4.0	0.0796	0.0052	0.0120	-0.0471	-0.0366	-0.0018
3820.8	-2.0	0.0799	0.0064	0.0115	-0.0394	-0.0367	-0.0037
3801.7	0.0	0.0812	0.0098	0.0146	-0.0351	-0.0386	-0.0070
3801.7	2.0	0.0834	0.0144	0.0158	-0.0332	-0.0431	-0.0094

27 Run# 33

Dynamic Pressure (N/m ²)	Angle of Attack (deg)	D/q (m ²)	L/q (m ²)	SF/q (m ²)	PM/q (m ³)	YM/q (m ³)	RM/q (m ³)
1905.6	0.0	0.0705	0.0189	0.0133	-0.0390	-0.0349	-0.0084
2872.8	0.0	0.0729	0.0147	0.0133	-0.0338	-0.0364	-0.0080
3835.2	-8.0	0.0727	0.0063	0.0119	-0.0725	-0.0378	0.0031
3806.5	-8.0	0.0726	0.0048	0.0118	-0.0708	-0.0377	0.0019
3816.0	-8.0	0.0727	0.0063	0.0127	-0.0730	-0.0379	0.0031
3835.2	-6.0	0.0727	0.0074	0.0113	-0.0620	-0.0370	0.0035
3835.2	-4.0	0.0733	0.0085	0.0115	-0.0504	-0.0361	0.0021
3816.0	-2.0	0.0739	0.0117	0.0118	-0.0429	-0.0367	-0.0001
3825.6	0.0	0.0749	0.0157	0.0129	-0.0369	-0.0397	-0.0034
3820.8	2.0	0.0775	0.0200	0.0158	-0.0313	-0.0437	-0.0072
3830.4	2.0	0.0778	0.0203	0.0163	-0.0317	-0.0433	-0.0069
3811.2	2.0	0.0778	0.0205	0.0159	-0.0321	-0.0430	-0.0071
3806.5	-2.0	0.0742	0.0120	0.0122	-0.0442	-0.0367	-0.0046

Run# 34

Dynamic Pressure (N/m ²)	Angle of Attack (deg)	D/q (m ²)	L/q (m ²)	SF/q (m ²)	PM/q (m ³)	YM/q (m ³)	RM/q (m ³)
3806.5	-8.0	0.0763	0.0029	0.0129	-0.0678	-0.0398	0.0014
3811.2	-2.0	0.0760	0.0104	0.0118	-0.0417	-0.0378	-0.0021
3796.9	0.0	0.0770	0.0159	0.0137	-0.0369	-0.0394	-0.0043
3840.0	2.0	0.0795	0.0192	0.0167	-0.0301	-0.0438	-0.0091

Run# 35

Dynamic Pressure (N/m ²)	Angle of Attack (deg)	D/q (m ²)	L/q (m ²)	SF/q (m ²)	PM/q (m ³)	YM/q (m ³)	RM/q (m ³)
3868.7	-8.0	0.0743	0.0026	0.0121	-0.0653	-0.0395	0.0015
3873.5	-6.0	0.0737	0.0047	0.0108	-0.0557	-0.0378	0.0016
3840.0	-4.0	0.0738	0.0065	0.0111	-0.0459	-0.0380	-0.0007
3840.0	-2.0	0.0741	0.0104	0.0120	-0.0398	-0.0379	-0.0020
3811.2	0.0	0.0750	0.0140	0.0128	-0.0339	-0.0403	-0.0050
3772.9	2.0	0.0773	0.0193	0.0162	-0.0302	-0.0438	-0.0088
3782.5	2.0	0.0775	0.0193	0.0167	-0.0298	-0.0448	-0.0092
3782.5	2.0	0.0776	0.0139	0.0163	-0.0293	-0.0436	-0.0093

Run# 36

Dynamic Pressure (N/m ²)	Angle of Attack (deg)	D/q (m ²)	L/q (m ²)	SF/q (m ²)	PM/q (m ³)	YM/q (m ³)	RM/q (m ³)
1934.4	0.0	0.0651	0.0021	0.0108	-0.0350	-0.0367	-0.0079
2901.5	0.0	0.0676	-0.0014	0.0115	-0.0311	-0.0384	-0.0081
3830.4	-8.0	0.0704	0.0003	0.0117	-0.0676	-0.0369	-0.0060

Run# 37

Dynamic Pressure (N/m ²)	Angle of Attack (deg)	D/q (m ²)	L/q (m ²)	SF/q (m ²)	PM/q (m ³)	YM/q (m ³)	RM/q (m ³)
1943.9	0.0	0.0664	0.0030	0.0119	-0.0366	-0.0358	-0.0095
2877.6	0.0	0.0688	-0.0005	0.0113	-0.0330	-0.0386	-0.0077
3873.5	-8.0	0.0715	0.0040	0.0109	-0.0765	-0.0387	-0.0002
3849.6	-6.0	0.0703	0.0029	0.0109	-0.0653	-0.0372	0.0010
3844.8	-4.0	0.0701	-0.0027	0.0108	-0.0478	-0.0360	-0.0020
3825.6	-2.0	0.0700	-0.0009	0.0106	-0.0410	-0.0379	-0.0021
3820.8	0.0	0.0704	0.0003	0.0121	-0.0351	-0.0398	-0.0048
3777.7	2.0	0.0724	0.0020	0.0141	-0.0294	-0.0438	-0.0074

Run# 38

Dynamic Pressure (N/m ²)	Angle of Attack (deg)	D/q (m ²)	L/q (m ²)	SF/q (m ²)	PM/q (m ³)	YM/q (m ³)	RM/q (m ³)
1934.4	0.0	0.0692	0.0159	0.0136	-0.0332	-0.0348	-0.0092
2882.4	0.0	0.0724	0.0136	0.0130	-0.0320	-0.0382	-0.0064
3849.6	0.0	0.0748	0.0146	0.0120	-0.0339	-0.0392	-0.0078

Run# 39

Dynamic Pressure (N/m ²)	Angle of Attack (deg)	D/q (m ²)	L/q (m ²)	SF/q (m ²)	PM/q (m ³)	YM/q (m ³)	RM/q (m ³)
1943.8	0.0	0.0712	0.0181	0.0144	-0.0377	-0.0361	-0.0098
2868.0	0.0	0.0740	0.0154	0.0132	-0.0345	-0.0392	-0.0079
3806.5	-8.0	0.0737	0.0064	0.0147	-0.0732	-0.0378	0.0027
3849.6	-2.0	0.0744	0.0114	0.0134	-0.0436	-0.0385	-0.0012
3820.8	0.0	0.0754	0.0154	0.0134	-0.0366	-0.0399	-0.0043
3801.7	2.0	0.0776	0.0202	0.0170	-0.0310	-0.0434	-0.0090

Run# 40

Dynamic Pressure (N/m ²)	Angle of Attack (deg)	D/q (m ²)	L/q (m ²)	SF/q (m ²)	PM/q (m ³)	YM/q (m ³)	RM/q (m ³)
1924.8	0.0	0.0703	0.0190	0.0125	-0.0390	-0.0354	-0.0074
2892.0	0.0	0.0732	0.0158	0.0138	-0.0356	-0.0380	-0.0067
3859.1	-8.0	0.0740	0.0065	0.0136	-0.0735	-0.0376	0.0008
3811.2	-2.0	0.0745	0.0119	0.0137	-0.0435	-0.0362	-0.0030
3801.7	0.0	0.0755	0.0152	0.0149	-0.0355	-0.0386	-0.0062
3849.6	2.0	0.0775	0.0203	0.0168	-0.0315	-0.0423	-0.0101

Run# 41

Dynamic Pressure (N/m ²)	Angle of Attack (deg)	D/q (m ²)	L/q (m ²)	SF/q (m ²)	PM/q (m ³)	YM/q (m ³)	RM/q (m ³)
1924.8	0.0	0.0698	0.0180	0.0132	-0.0379	-0.0349	-0.0077
2863.2	0.0	0.0729	0.0151	0.0127	-0.0344	-0.0373	-0.0071
3820.8	-8.0	0.0737	0.0081	0.0139	-0.0762	-0.0380	0.0030
3840.0	-2.0	0.0743	0.0107	0.0127	-0.0409	-0.0371	-0.0008
3820.8	0.0	0.0752	0.0150	0.0126	-0.0349	-0.0392	-0.0034
3825.6	2.0	0.0773	0.0202	0.0163	-0.0308	-0.0424	-0.0070

Run# 42

Dynamic Pressure (N/m ²)	Angle of Attack (deg)	D/q (m ²)	L/q (m ²)	SF/q (m ²)	PM/q (m ³)	YM/q (m ³)	RM/q (m ³)
1915.2	0.0	0.0720	0.0163	0.0111	-0.0362	-0.0346	-0.0084
2868.0	0.0	0.0754	0.0154	0.0113	-0.0367	-0.0381	-0.0077
2858.4	0.0	0.0752	0.0154	0.0114	-0.0363	-0.0381	-0.0073
2868.0	0.0	0.0754	0.0149	0.0135	-0.0359	-0.0383	-0.0076
3849.6	-8.0	0.0775	0.0010	0.0111	-0.0674	-0.0414	-0.0022
3849.6	-6.0	0.0758	0.0028	0.0103	-0.0567	-0.0385	-0.0020
3816.0	-4.0	0.0754	0.0031	0.0114	-0.0442	-0.0365	-0.0041
3820.8	-2.0	0.0759	0.0071	0.0092	-0.0375	-0.0380	-0.0065
3820.8	0.0	0.0768	0.0130	0.0115	-0.0344	-0.0399	-0.0088
3811.2	2.0	0.0789	0.0190	0.0144	-0.0313	-0.0436	-0.0122
1910.4	0.0	0.0692	0.0186	0.0151	-0.0387	-0.0366	-0.0134
2887.2	0.0	0.0732	0.0139	0.0139	-0.0394	-0.0391	-0.0093
3863.9	-8.0	0.0759	0.0055	0.0122	-0.0748	-0.0417	0.0004
3811.2	-2.0	0.0752	0.0093	0.0116	-0.0413	-0.0377	0.0050
3820.8	0.0	0.0761	0.0151	0.0113	-0.0379	-0.0401	-0.0074
3792.1	2.0	0.0781	0.0202	0.0142	-0.0315	-0.0437	-0.0118

Run# 43

Dynamic Pressure (N/m ²)	Angle of Attack (deg)	D/q (m ²)	L/q (m ²)	SF/q (m ²)	PM/q (m ³)	YM/q (m ³)	RM/q (m ³)
1896.0	0.0	0.0760	0.0106	0.0131	-0.0370	-0.0360	-0.0091
2872.8	0.0	0.0785	0.0108	0.0124	-0.0384	-0.0393	-0.0066
3820.8	-8.0	0.0803	0.0081	0.0133	-0.0731	-0.0398	0.0040
3830.4	-6.0	0.0798	0.0055	0.0134	-0.0583	-0.0384	0.0036
3820.8	-4.0	0.0793	0.0036	0.0132	-0.0469	-0.0380	0.0005
3816.0	-2.0	0.0800	0.0056	0.0117	-0.0408	-0.0387	-0.0012
3806.5	0.0	0.0804	0.0090	0.0132	-0.0368	-0.0402	-0.0036
3796.9	2.0	0.0821	0.0128	0.0157	-0.0321	-0.0428	-0.0077
1939.1	0.0	0.0734	0.0119	0.0128	-0.0390	-0.0369	-0.0077
2882.4	0.0	0.0775	0.0111	0.0140	-0.0388	-0.0389	-0.0059
3840.0	-8.0	0.0795	0.0087	0.0139	-0.0749	-0.0384	0.0036
3840.0	-6.0	0.0793	0.0083	0.0145	-0.0737	-0.0400	0.0028
3849.6	-8.0	0.0793	0.0091	0.0144	-0.0743	-0.0396	0.0031
3806.5	-2.0	0.0789	0.0062	0.0134	-0.0419	-0.0373	-0.0012
3801.7	0.0	0.0798	0.0097	0.0124	-0.0373	-0.0410	-0.0043
3792.1	2.0	0.0818	0.0123	0.0151	-0.0328	-0.0437	-0.0080

Run# 44

Dynamic Pressure (N/m ²)	Angle of Attack (deg)	D/q (m ²)	L/q (m ²)	SF/q (m ²)	PM/q (m ³)	YM/q (m ³)	RM/q (m ³)
1900.8	0.0	0.0775	0.0154	0.0115	-0.0389	-0.0350	-0.0090
2863.2	0.0	0.0805	0.0154	0.0123	-0.0384	-0.0380	-0.0057
3816.0	-8.0	0.0815	0.0115	0.0105	-0.0752	-0.0380	0.0000
3806.5	-6.0	0.0809	0.0106	0.0088	-0.0631	-0.0369	0.0017
3849.6	-4.0	0.0815	0.0079	0.0103	-0.0495	-0.0384	-0.0008
3816.0	-2.0	0.0818	0.0093	0.0111	-0.0412	-0.0367	-0.0025
3820.8	0.0	0.0825	0.0125	0.0119	-0.0361	-0.0390	-0.0054
3825.6	2.0	0.0846	0.0152	0.0137	-0.0313	-0.0424	-0.0083
1900.8	0.0	0.0761	0.0152	0.0108	-0.0379	-0.0341	-0.0127
2868.0	0.0	0.0799	0.0136	0.0104	-0.0372	-0.0371	-0.0098
3825.6	-8.0	0.0810	0.0127	0.0095	-0.0766	-0.0382	0.0010
3840.0	-2.0	0.0818	0.0102	0.0098	-0.0428	-0.0385	-0.0024
3816.0	0.0	0.0824	0.0129	0.0106	-0.0373	-0.0389	-0.0042
3792.1	2.0	0.0841	0.0155	0.0128	-0.0308	-0.0423	-0.0089

33

Run# 45

Dynamic Pressure (N/m ²)	Angle of Attack (deg)	D/q (m ²)	L/q (m ²)	SF/q (m ²)	PM/q (m ³)	YM/q (m ³)	RM/q (m ³)
1915.2	0.0	0.0706	0.0163	0.0111	-0.0378	-0.0347	-0.0084
2882.4	0.0	0.0735	0.0156	0.0128	-0.0393	-0.0366	-0.0056
3849.6	-8.0	0.0748	0.0059	0.0119	-0.0749	-0.0364	0.0027
3835.2	-6.0	0.0741	0.0053	0.0109	-0.0620	-0.0349	0.0024
3820.8	-4.0	0.0750	0.0057	0.0097	-0.0505	-0.0357	0.0003
3811.2	-2.0	0.0750	0.0091	0.0099	-0.0438	-0.0355	-0.0013
3792.1	0.0	0.0758	0.0129	0.0111	-0.0386	-0.0384	-0.0039
3854.3	2.0	0.0786	0.0148	0.0140	-0.0314	-0.0408	-0.0082
1915.2	0.0	0.0708	0.0151	0.0098	-0.0385	-0.0322	-0.0098
2896.7	0.0	0.0737	0.0124	0.0123	-0.0362	-0.0359	-0.0085
3859.1	-8.0	0.0745	0.0045	0.0113	-0.0738	-0.0367	0.0010
3811.2	-2.0	0.0749	0.0083	0.0098	-0.0426	-0.0356	-0.0013
3816.0	0.0	0.0760	0.0120	0.0122	-0.0370	-0.0374	-0.0047
3830.4	2.0	0.0782	0.0147	0.0137	-0.0314	-0.0419	-0.0084

Run# 46

Dynamic Pressure (N/m ²)	Angle of Attack (deg)	D/q (m ²)	L/q (m ²)	SF/q (m ²)	PM/q (m ³)	YM/q (m ³)	RM/q (m ³)
1943.9	0.0	0.0796	0.0201	0.0082	-0.0375	-0.0363	-0.0081
2892.0	0.0	0.0826	0.0178	0.0082	-0.0348	-0.0393	-0.0080
3854.3	-8.0	0.0836	0.0042	0.0090	-0.0668	-0.0398	-0.0005
3868.7	-6.0	0.0823	0.0056	0.0084	-0.0560	-0.0381	-0.0001
3840.0	-4.0	0.0820	0.0066	0.0083	-0.0439	-0.0368	-0.0022
3825.6	-2.0	0.0829	0.0108	0.0086	-0.0370	-0.0372	-0.0043
3796.9	0.0	0.0841	0.0146	0.0095	-0.0305	-0.0391	-0.0071
3820.8	0.0	0.0842	0.0146	0.0107	-0.0307	-0.0392	-0.0067
3811.2	0.0	0.0840	0.0153	0.0086	-0.0320	-0.0396	-0.0082
3772.9	2.0	0.0869	0.0203	0.0126	-0.0251	-0.0433	-0.0108
1953.5	0.0	0.0765	0.0198	0.0084	-0.0370	-0.0342	-0.0110
3849.6	-8.0	0.0825	0.0097	0.0097	-0.0694	-0.0396	-0.0004
3854.3	-2.0	0.0827	0.0126	0.0085	-0.0409	-0.0375	-0.0033
3825.6	0.0	0.0842	0.0156	0.0102	-0.0321	-0.0399	-0.0067
3801.7	2.0	0.0865	0.0195	0.0131	-0.0247	-0.0424	-0.0119

Run# 47

Dynamic Pressure (N/m ²)	Angle of Attack (deg)	D/q (m ²)	L/q (m ²)	SF/q (m ²)	PM/q (m ³)	YM/q (m ³)	RM/q (m ³)
1924.8	0.0	0.0774	0.0226	0.0081	-0.0398	-0.0355	-0.0075
2877.6	0.0	0.0804	0.0193	0.0077	-0.0362	-0.0375	-0.0067
3840.0	-8.0	0.0813	0.0090	0.0083	-0.0716	-0.0393	0.0001
3835.2	-6.0	0.0806	0.0096	0.0072	-0.0599	-0.0378	0.0000
3796.9	-4.0	0.0807	0.0100	0.0076	-0.0480	-0.0367	-0.0024
3806.5	-2.0	0.0810	0.0150	0.0068	-0.0429	-0.0373	-0.0029
3868.7	0.0	0.0824	0.0184	0.0083	-0.0355	-0.0389	-0.0057
3830.4	2.0	0.0849	0.0219	0.0095	-0.0267	-0.0431	-0.0105
1943.9	0.0	0.0748	0.0222	0.0078	-0.0386	-0.0355	-0.0112
2901.5	0.0	0.0793	0.0196	0.0071	-0.0356	-0.0385	-0.0090
3844.8	-8.0	0.0802	0.0095	0.0080	-0.0735	-0.0402	-0.0001
3811.2	-2.0	0.0806	0.0153	0.0058	-0.0429	-0.0387	-0.0029
3792.1	0.0	0.0820	0.0188	0.0091	-0.0349	-0.0395	-0.0062
3806.5	2.0	0.0844	0.0231	0.0099	-0.0285	-0.0438	-0.0100

Run# 49

Dynamic Pressure (N/m ²)	Angle of Attack (deg)	D/q (m ²)	L/q (m ²)	SF/q (m ²)	PM/q (m ³)	YM/q (m ³)	RM/q (m ³)
3854.3	-8.0	0.0758	0.0110	0.0115	-0.0749	-0.0376	0.0018
3854.3	-6.0	0.0752	0.0125	0.0112	-0.0652	-0.0370	0.0029
3811.2	-4.0	0.0754	0.0109	0.0095	-0.0507	-0.0365	0.0009
3796.9	-2.0	0.0762	0.0139	0.0102	-0.0434	-0.0360	-0.0013
3782.5	0.0	0.0771	0.0183	0.0102	-0.0373	-0.0388	-0.0040
3801.7	2.0	0.0791	0.0227	0.0135	-0.0319	-0.0418	-0.0078

Run# 50

35

Dynamic Pressure: (N/m ²)	Angle of Attack (deg)	D/q (m ²)	L/q (m ²)	SF/q (m ²)	PM/q (m ³)	YM/q (m ³)	RM/q (m ³)
1929.6	0.0	0.0722	0.0189	0.0115	-0.0371	-0.0359	-0.0102
2858.4	0.0	0.0752	0.0168	0.0104	-0.0351	-0.0377	-0.0080
3835.2	0.0	0.0771	0.0182	0.0102	-0.0381	-0.0387	-0.0076
1915.2	0.0	0.0701	0.0186	0.0098	-0.0360	-0.0355	-0.0108
2887.2	0.0	0.0743	0.0183	0.0108	-0.0365	-0.0379	-0.0075
3835.2	-8.0	0.0747	0.0101	0.0113	-0.0743	-0.0395	0.0018
3840.0	-2.0	0.0758	0.0148	0.0102	-0.0449	-0.0370	0.0010
3835.2	0.0	0.0769	0.0182	0.0114	-0.0380	-0.0402	-0.0045
3796.9	2.0	0.0790	0.0233	0.0149	-0.0326	-0.0434	-0.0079

Run# 51

Dynamic Pressure (N/m ²)	Angle of Attack (deg)	D/q (m ²)	L/q (m ²)	SF/q (m ²)	PM/q (m ³)	YM/q (m ³)	RM/q (m ³)
1924.8	0.0	0.0705	0.0166	0.0109	-0.0369	-0.0355	-0.0092
2872.8	0.0	0.0734	0.0147	0.0115	-0.0357	-0.0376	-0.0074
3873.5	-8.0	0.0753	0.0022	0.0125	-0.0696	-0.0403	0.0012
3863.9	-6.0	0.0740	0.0047	0.0122	-0.0586	-0.0383	0.0014
3844.8	-4.0	0.0742	0.0064	0.0119	-0.0495	-0.0375	0.0004
3820.8	-2.0	0.0743	0.0104	0.0112	-0.0426	-0.0381	-0.0011
3825.6	0.0	0.0750	0.0126	0.0131	-0.0329	-0.0401	-0.0051
3849.6	0.0	0.0750	0.0131	0.0131	-0.0332	-0.0394	-0.0049
3840.0	0.0	0.0749	0.0130	0.0131	-0.0342	-0.0391	-0.0047
3806.5	2.0	0.0771	0.0146	0.0146	-0.0294	-0.0440	-0.0085
1896.0	0.0	0.0687	0.0171	0.0141	-0.0410	-0.0371	-0.0083
2892.0	0.0	0.0728	0.0172	0.0137	-0.0397	-0.0387	-0.0062
3840.0	-8.0	0.0743	0.0051	0.0132	-0.0739	-0.0394	0.0016
3816.0	-2.0	0.0740	0.0104	0.0133	-0.0428	-0.0383	-0.0018
3801.7	0.0	0.0749	0.0136	0.0132	-0.0347	-0.0410	-0.0044
3825.6	0.0	0.0746	0.0138	0.0137	-0.0351	-0.0404	-0.0041
3801.7	0.0	0.0750	0.0149	0.0131	-0.0355	-0.0403	-0.0042
3796.9	2.0	0.0772	0.0184	0.0150	-0.0304	-0.0458	-0.0084

Run# 53

Dynamic Pressure (N/m ²)	Angle of Attack (deg)	D/q (m ²)	L/q (m ²)	SF/q (m ²)	PM/q (m ³)	YM/q (m ³)	RM/q (m ³)
1929.6	0.0	0.0765	0.0214	0.0060	-0.0363	-0.0340	-0.0090
2896.7	0.0	0.0794	0.0193	0.0064	-0.0337	-0.0361	-0.0076
3844.8	-8.0	0.0801	0.0153	0.0094	-0.0738	-0.0379	0.0016
3820.8	-6.0	0.0806	0.0140	0.0098	-0.0589	-0.0366	0.0005
3849.6	-4.0	0.0813	0.0141	0.0070	-0.0483	-0.0370	0.0000
3840.0	-2.0	0.0807	0.0160	0.0056	-0.0408	-0.0360	-0.0026
3806.5	0.0	0.0823	0.0188	0.0077	-0.0340	-0.0392	-0.0050
3806.5	2.0	0.0895	0.0261	0.0130	-0.0274	-0.0421	-0.0090
1900.8	0.0	0.0747	0.0248	0.0080	-0.0395	-0.0382	-0.0079
1905.6	0.0	0.0747	0.0250	0.0068	-0.0401	-0.0370	-0.0079
1900.8	0.0	0.0749	0.0246	0.0073	-0.0389	-0.0371	-0.0084
2863.2	0.0	0.0783	0.0205	0.0062	-0.0342	-0.0381	-0.0081
3820.8	-8.0	0.0793	0.0141	0.0098	-0.0727	-0.0380	0.0007
3806.5	-2.0	0.0804	0.0154	0.0053	-0.0403	-0.0374	-0.0025
3806.5	0.0	0.0818	0.0195	0.0071	-0.0349	-0.0391	-0.0049
3849.6	2.0	0.0893	0.0263	0.0126	-0.0281	-0.0426	-0.0083

Run# 54

Dynamic Pressure (N/m ²)	Angle of Attack (deg)	D/q (m ²)	L/q (m ²)	SF/q (m ²)	PM/q (m ³)	YM/q (m ³)	RM/q (m ³)
1910.4	0.0	0.0831	0.0254	0.0049	-0.0370	-0.0335	-0.0075
2858.4	0.0	0.0864	0.0218	0.0061	-0.0322	-0.0361	-0.0079
3811.2	-8.0	0.0845	0.0140	-0.0015	-0.0711	-0.0398	0.0011
3825.6	-6.0	0.0843	0.0135	0.0005	-0.0569	-0.0368	0.0013
3840.0	-4.0	0.0860	0.0151	0.0014	-0.0482	-0.0361	0.0005
3830.4	-2.0	0.0870	0.0187	0.0037	-0.0417	-0.0378	-0.0004
3825.6	0.0	0.0887	0.0220	0.0060	-0.0333	-0.0393	-0.0034
3816.0	2.0	0.0912	0.0258	0.0092	-0.0268	-0.0423	-0.0078
1905.6	0.0	0.0810	0.0271	0.0063	-0.0378	-0.0355	-0.0057
2877.6	0.0	0.0850	0.0232	0.0057	-0.0323	-0.0384	-0.0060
3844.8	-8.0	0.0849	0.0123	-0.0009	-0.0683	-0.0410	-0.0004
3801.7	-2.0	0.0867	0.0190	0.0041	-0.0418	-0.0365	-0.0005
3806.5	0.0	0.0883	0.0227	0.0064	-0.0343	-0.0388	-0.0032
3820.8	2.0	0.0912	0.0265	0.0084	-0.0277	-0.0427	-0.0082
3811.2	0.0	0.0886	0.0214	0.0068	-0.0326	-0.0381	-0.0087

Run# 55

Dynamic Pressure (N/m ²)	Angle of Attack (deg)	D/q (m ²)	L/q (m ²)	SF/q (m ²)	PM/q (m ³)	YM/q (m ³)	RM/q (m ³)
1910.4	0.0	0.0801	0.0175	0.0123	-0.0380	-0.0354	-0.0076
1905.6	0.0	0.0798	0.0175	0.0128	-0.0379	-0.0351	-0.0070
1915.2	0.0	0.0799	0.0174	0.0109	-0.0379	-0.0356	-0.0071
2868.0	0.0	0.0831	0.0116	0.0121	-0.0311	-0.0378	-0.0080
3830.4	-8.0	0.0821	0.0059	0.0127	-0.0634	-0.0368	-0.0008
3820.8	-6.0	0.0824	0.0047	0.0108	-0.0512	-0.0360	-0.0003
3806.5	-4.0	0.0833	0.0046	0.0113	-0.0409	-0.0374	-0.0005
3811.2	-2.0	0.0840	0.0065	0.0117	-0.0350	-0.0363	-0.0025
3854.3	0.0	0.0851	0.0102	0.0128	-0.0306	-0.0391	-0.0052
3835.2	2.0	0.0872	0.0130	0.0147	-0.0252	-0.0425	-0.0094
1924.8	0.0	0.0779	0.0162	0.0127	-0.0373	-0.0353	-0.0082
2906.3	0.0	0.0825	0.0116	0.0132	-0.0315	-0.0384	-0.0088
3844.8	-8.0	0.0821	0.0097	0.0130	-0.0688	-0.0393	0.0015
3825.6	-2.0	0.0836	0.0073	0.0121	-0.0354	-0.0373	-0.0025
3820.8	0.0	0.0845	0.0119	0.0134	-0.0311	-0.0412	-0.0057
3840.0	2.0	0.0872	0.0137	0.0162	-0.0258	-0.0442	-0.0095

Run# 56

Dynamic Pressure (N/m ²)	Angle of Attack (deg)	D/q (m ²)	L/q (m ²)	SF/q (m ²)	PM/q (m ³)	YM/q (m ³)	RM/q (m ³)
1939.1	0.0	0.0794	0.0158	0.0117	-0.0380	-0.0348	-0.0079
2863.2	0.0	0.0825	0.0112	0.0115	-0.0318	-0.0371	-0.0086
3835.2	-8.0	0.0815	0.0067	0.0113	-0.0663	-0.0372	-0.0004
3811.2	-2.0	0.0833	0.0079	0.0110	-0.0370	-0.0375	-0.0023
3816.0	0.0	0.0845	0.0111	0.0124	-0.0319	-0.0395	-0.0058
3825.6	2.0	0.0869	0.0142	0.0155	-0.0274	-0.0431	-0.0091
3825.6	0.0	0.0845	0.0117	0.0129	-0.0323	-0.0391	-0.0084

Run# 57

Dynamic Pressure (N/m ²)	Angle of Attack (deg)	D/q (m ²)	L/q (m ²)	SF/q (m ²)	PM/q (m ³)	YM/q (m ³)	RM/q (m ³)
1958.3	0.0	0.0688	0.0179	0.0154	-0.0363	-0.0358	-0.0081
3835.2	-8.0	0.0724	-0.0005	0.0158	-0.0663	-0.0374	0.0004
3820.8	-6.0	0.0718	0.0140	0.0140	-0.0552	-0.0364	0.0012
3782.5	-4.0	0.0720	0.0028	0.0139	-0.0435	-0.0363	-0.0005
3825.6	-2.0	0.0728	0.0072	0.0153	-0.0370	-0.0364	-0.0023
3816.0	0.0	0.0738	0.0127	0.0147	-0.0337	-0.0391	-0.0051
3782.5	2.0	0.0764	0.0174	0.0196	-0.0272	-0.0430	-0.0099
1910.4	0.0	0.0668	0.0182	0.0140	-0.0374	-0.0358	-0.0091
2863.2	0.0	0.0710	0.0129	0.0154	-0.0320	-0.0367	-0.0081
3825.6	0.0	0.0748	0.0123	0.0170	-0.0324	-0.0394	-0.0086

Run# 58

Dynamic Pressure (N/m ²)	Angle of Attack (deg)	D/q (m ²)	L/q (m ²)	SF/q (m ²)	PM/q (m ³)	YM/q (m ³)	RM/q (m ³)
1896.0	0.0	0.0800	0.0235	0.0127	-0.0353	-0.0339	-0.0090
2868.0	0.0	0.0836	0.0183	0.0129	-0.0283	-0.0369	-0.0086
3835.2	-8.0	0.0829	0.0078	0.0118	-0.0653	-0.0373	0.0007
3816.0	-8.0	0.0826	0.0070	0.0133	-0.0645	-0.0369	0.0004
3811.2	-8.0	0.0829	0.0082	0.0120	-0.0657	-0.0375	0.0006
3820.8	-6.0	0.0830	0.0095	0.0120	-0.0554	-0.0365	0.0015
3825.6	-4.0	0.0844	0.0100	0.0123	-0.0438	-0.0373	0.0004
3849.6	-2.0	0.0849	0.0138	0.0114	-0.0366	-0.0372	-0.0021
3825.6	0.0	0.0859	0.0192	0.0127	-0.0314	-0.0402	-0.0043
3849.6	2.0	0.0893	0.0240	0.0158	-0.0241	-0.0444	-0.0085
2887.2	0.0	0.0826	0.0193	0.0140	-0.0298	-0.0365	-0.0100
3787.3	0.0	0.0862	0.0195	0.0128	-0.0321	-0.0398	-0.0083

Run# 59

Dynamic Pressure (N/m ²)	Angle of Attack (deg)	D/q (m ²)	L/q (m ²)	SF/q (m ²)	PM/q (m ³)	YM/q (m ³)	RM/q (m ³)
1920.0	0.0	0.0795	0.0273	0.0134	-0.0377	-0.0327	-0.0080
2872.8	0.0	0.0835	0.0225	0.0142	-0.0311	-0.0365	-0.0081
3796.9	-8.0	0.0825	0.0134	0.0129	-0.0710	-0.0368	0.0017
3825.6	-6.0	0.0834	0.0144	0.0123	-0.0589	-0.0352	0.0020
3835.2	-4.0	0.0843	0.0145	0.0118	-0.0470	-0.0361	0.0013
3806.5	-4.0	0.0840	0.0137	0.0124	-0.0453	-0.0345	0.0004
3811.2	-4.0	0.0844	0.0141	0.0113	-0.0463	-0.0351	0.0004
3820.8	-2.0	0.0850	0.0194	0.0119	-0.0407	-0.0359	-0.0004
3840.0	0.0	0.0866	0.0250	0.0136	-0.0352	-0.0390	-0.0030
3801.7	2.0	0.0888	0.0301	0.0160	-0.0291	-0.0420	-0.0082
3796.9	2.0	0.0888	0.0294	0.0165	-0.0282	-0.0421	-0.0087
3811.2	2.0	0.0885	0.0293	0.0161	-0.0281	-0.0422	-0.0085
1929.6	0.0	0.0779	0.0279	0.0138	-0.0377	-0.0318	-0.0077
1929.6	0.0	0.0777	0.0281	0.0113	-0.0387	-0.0315	-0.0061
1929.6	0.0	0.0779	0.0288	0.0143	-0.0394	-0.0319	-0.0060
2853.6	0.0	0.0829	0.0232	0.0140	-0.0335	-0.0341	-0.0074
3811.2	-8.0	0.0829	0.0153	0.0123	-0.0737	-0.0365	0.0020
3801.7	-2.0	0.0851	0.0192	0.0129	-0.0411	-0.0361	-0.0004
3806.5	0.0	0.0862	0.0247	0.0127	-0.0357	-0.0388	-0.0039
3840.0	2.0	0.0884	0.0292	0.0166	-0.0280	-0.0426	-0.0073

Run#	Dynamic Pressure (N/m ²)	Angle of Attack (deg)	D/q (m ²)	L/q (m ²)	SF/q (m ²)	PM/q (m ³)	YM/q (m ³)	RM/q (m ³)
1929.6		0.0	0.0786	0.0302	0.0127	-0.0376	-0.0343	-0.0074
2858.4		0.0	0.0836	0.0274	0.0128	-0.0347	-0.0377	-0.0064
3835.2		-8.0	0.0818	0.0180	0.0132	-0.0732	-0.0357	0.0008
3825.6		-6.0	0.0823	0.0184	0.0114	-0.0599	-0.0369	0.0011
3796.9		-4.0	0.0834	0.0185	0.0107	-0.0487	-0.0366	-0.0001
3806.5		-2.0	0.0840	0.0230	0.0125	-0.0420	-0.0367	-0.0012
3840.0		0.0	0.0857	0.0269	0.0147	-0.0354	-0.0385	-0.0045
3840.0		2.0	0.0877	0.0310	0.0158	-0.0288	-0.0427	-0.0083
1924.8		0.0	0.0770	0.0289	0.0141	-0.0370	-0.0359	-0.0038
2877.6		0.0	0.0821	0.0288	0.0119	-0.0373	-0.0374	-0.0034
3854.3		0.0	0.0860	0.0283	0.0135	-0.0375	-0.0399	-0.0052

Run#	Dynamic Pressure (N/m ²)	Angle of Attack (deg)	D/q (m ²)	L/q (m ²)	SF/q (m ²)	PM/q (m ³)	YM/q (m ³)	RM/q (m ³)
1934.4		0.0	0.0826	0.0216	0.0122	-0.0360	-0.0346	-0.0090
2858.4		0.0	0.0868	0.0202	0.0128	-0.0349	-0.0387	-0.0083
3859.1		-8.0	0.0868	0.0135	0.0127	-0.0687	-0.0389	0.0007
3844.8		-6.0	0.0865	0.0137	0.0115	-0.0575	-0.0375	0.0000
3830.4		-4.0	0.0873	0.0132	0.0111	-0.0460	-0.0383	-0.0013
3825.6		-2.0	0.0876	0.0160	0.0113	-0.0391	-0.0374	-0.0033
3806.5		0.0	0.0889	0.0217	0.0134	-0.0360	-0.0406	-0.0086
3796.9		2.0	0.0910	0.0241	0.0157	-0.0302	-0.0436	-0.0113
1929.6		0.0	0.0800	0.0219	0.0120	-0.0354	-0.0348	-0.0110
2844.1		0.0	0.0856	0.0208	0.0125	-0.0349	-0.0377	-0.0102
3835.2		-3.0	0.0855	0.0154	0.0119	-0.0724	-0.0385	-0.0001
3787.3		-2.0	0.0875	0.0170	0.0116	-0.0409	-0.0381	-0.0031
3801.7		0.0	0.0886	0.0204	0.0132	-0.0357	-0.0390	-0.0054
3825.6		2.0	0.0909	0.0234	0.0150	-0.0292	-0.0448	-0.0102

Run# 62

Dynamic Pressure (N/m ²)	Angle of Attack (deg)	D/q (m ²)	L/q (m ²)	SF/q (m ²)	PM/q (m ³)	YM/q (m ³)	RM/q (m ³)
1924.8	0.0	0.0802	0.0307	0.0129	-0.0365	-0.0341	-0.0067
2887.2	0.0	0.0846	0.0280	0.0125	-0.0345	-0.0375	-0.0074
3863.9	-8.0	0.0845	0.0147	0.0132	-0.0672	-0.0372	0.0005
3849.6	-6.0	0.0845	0.0159	0.0119	-0.0558	-0.0361	0.0011
3811.2	-4.0	0.0854	0.0176	0.0109	-0.0458	-0.0362	-0.0006
3849.6	-2.0	0.0862	0.0217	0.0118	-0.0401	-0.0366	-0.0020
3811.2	0.0	0.0877	0.0273	0.0121	-0.0354	-0.0397	-0.0041
3816.0	2.0	0.0900	0.0314	0.0169	-0.0287	-0.0429	-0.0093
1948.7	0.0	0.0783	0.0288	0.0137	-0.0350	-0.0346	-0.0075
2858.4	0.0	0.0831	0.0254	0.0140	-0.0310	-0.0378	-0.0071

Run# 63

Dynamic Pressure (N/m ²)	Angle of Attack (deg)	D/q (m ²)	L/q (m ²)	SF/q (m ²)	PM/q (m ³)	YM/q (m ³)	RM/q (m ³)
1929.6	0.0	0.0689	0.0178	0.0150	-0.0361	-0.0354	-0.0087
2868.0	0.0	0.0724	0.0147	0.0155	-0.0331	-0.0383	-0.0081
3840.0	-8.0	0.0747	0.0016	0.0141	-0.0692	-0.0377	-0.0003
3816.0	-6.0	0.0740	0.0035	0.0138	-0.0587	-0.0372	0.0010
3830.4	-4.0	0.0741	0.0049	0.0144	-0.0464	-0.0364	-0.0007
3844.8	-2.0	0.0751	0.0099	0.0138	-0.0418	-0.0366	-0.0026
3792.1	0.0	0.0759	0.0150	0.0154	-0.0368	-0.0389	-0.0051
3840.0	2.0	0.0776	0.0200	0.0190	-0.0314	-0.0439	-0.0092
1900.8	0.0	0.0686	0.0161	0.0145	-0.0336	-0.0350	-0.0124
2839.3	0.0	0.0722	0.0143	0.0166	-0.0325	-0.0377	-0.0108
3840.0	0.0	0.0760	0.0154	0.0154	-0.0362	-0.0403	-0.0094

Run# 64

Dynamic Pressure (N/m ²)	Angle of Attack (deg)	D/q (m ²)	L/q (m ²)	SF/q (m ²)	PM/q (m ³)	YM/q (m ³)	RM/q (m ³)
1905.6	0.0	0.0686	0.0208	0.0126	-0.0375	-0.0348	-0.0087
2877.6	0.0	0.0720	0.0161	0.0113	-0.0322	-0.0391	-0.0081
3801.7	-8.0	0.0723	0.0076	0.0128	-0.0731	-0.0377	0.0013
3792.1	-6.0	0.0721	0.0083	0.0123	-0.0612	-0.0366	0.0012
3811.2	-4.0	0.0732	0.0095	0.0105	-0.0508	-0.0359	-0.0002
3801.7	-2.0	0.0737	0.0122	0.0106	-0.0431	-0.0378	-0.0022
3811.2	0.0	0.0753	0.0168	0.0116	-0.0371	-0.0399	-0.0049
3787.3	2.0	0.0776	0.0208	0.0132	-0.0319	-0.0433	-0.0087

Run# 65

Dynamic Pressure (N/m ²)	Angle of Attack (deg)	D/q (m ²)	L/q (m ²)	SF/q (m ²)	PM/q (m ³)	YM/q (m ³)	RM/q (m ³)
1915.2	0.0	0.0748	0.0109	0.0121	-0.0347	-0.0344	-0.0112
2863.2	0.0	0.0774	0.0089	0.0124	-0.0330	-0.0374	-0.0087
3825.6	-8.0	0.0771	0.0107	0.0117	-0.0768	-0.0373	0.0019
3820.8	-6.0	0.0779	0.0092	0.0115	-0.0638	-0.0375	0.0019
3796.9	-4.0	0.0791	0.0070	0.0112	-0.0513	-0.0364	0.0000
3840.0	-2.0	0.0798	0.0086	0.0116	-0.0439	-0.0375	-0.0025
3830.4	0.0	0.0809	0.0114	0.0124	-0.0386	-0.0392	-0.0047
3801.7	2.0	0.0828	0.0142	0.0150	-0.0332	-0.0431	-0.0079
1910.4	0.0	0.0726	0.0133	0.0126	-0.0387	-0.0359	-0.0082
2892.0	0.0	0.0766	0.0092	0.0126	-0.0334	-0.0376	-0.0078
3825.6	-8.0	0.0770	0.0106	0.0119	-0.0768	-0.0355	0.0001
3806.5	-2.0	0.0798	0.0092	0.0122	-0.0448	-0.0378	-0.0014
3796.9	0.0	0.0811	0.0128	0.0143	-0.0399	-0.0396	-0.0043
3820.8	2.0	0.0831	0.0139	0.0165	-0.0320	-0.0442	-0.0088

Run# 66

Dynamic Pressure (N/m ²)	Angle of Attack (deg)	D/q (m ²)	L/q (m ²)	SF/q (m ²)	PM/q (m ³)	YM/q (m ³)	RM/q (m ³)
1920.0	0.0	0.0816	0.0171	0.0102	-0.0378	-0.0351	-0.0079
2872.8	0.0	0.0850	0.0144	0.0107	-0.0357	-0.0390	-0.0081
3835.2	-8.0	0.0843	0.0056	0.0114	-0.0675	-0.0377	0.0001
3825.6	-6.0	0.0848	0.0080	0.0105	-0.0590	-0.0367	0.0005
3830.4	-4.0	0.0849	0.0071	0.0102	-0.0490	-0.0370	-0.0008
3811.2	-2.0	0.0851	0.0090	0.0107	-0.0426	-0.0377	-0.0023
3777.7	0.0	0.0863	0.0125	0.0113	-0.0376	-0.0404	-0.0049
3811.2	2.0	0.0889	0.0147	0.0131	-0.0305	-0.0437	-0.0089
1924.8	0.0	0.0795	0.0180	0.0111	-0.0400	-0.0349	-0.0091
2887.2	0.0	0.0849	0.0145	0.0099	-0.0375	-0.0386	-0.0083
3825.6	0.0	0.0865	0.0116	0.0114	-0.0369	-0.0402	-0.0085

Run# 67

Dynamic Pressure (N/m ²)	Angle of Attack (deg)	D/q (m ²)	L/q (m ²)	SF/q (m ²)	PM/q (m ³)	YM/q (m ³)	RM/q (m ³)
2911.1	0.0	0.0839	0.0280	0.0076	-0.0343	-0.0387	-0.0084
3849.6	-8.0	0.0816	0.0132	0.0096	-0.0709	-0.0390	0.0008
3835.2	-6.0	0.0815	0.0155	0.0089	-0.0603	-0.0374	0.0011
3844.8	-4.0	0.0819	0.0172	0.0094	-0.0499	-0.0365	-0.0009
3806.5	-2.0	0.0825	0.0213	0.0092	-0.0427	-0.0379	-0.0021
3825.6	0.0	0.0842	0.0258	0.0098	-0.0370	-0.0405	-0.0047
3792.1	2.0	0.0883	0.0328	0.0108	-0.0311	-0.0433	-0.0078
1958.3	0.0	0.0786	0.0341	0.0093	-0.0393	-0.0343	-0.0080
2882.4	0.0	0.0826	0.0272	0.0079	-0.0335	-0.0378	-0.0088
3854.3	0.0	0.0841	0.0257	0.0099	-0.0368	-0.0394	-0.0081

Run# 68

Dynamic Pressure (N/m ²)	Angle of Attack (deg)	D/q (m ²)	L/q (m ²)	SF/q (m ²)	PM/q (m ³)	YM/q (m ³)	RM/q (m ³)
1910.4	0.0	0.0857	0.0442	0.0100	-0.0469	-0.0343	-0.0044
2858.4	0.0	0.0884	0.0378	0.0096	-0.0401	-0.0365	-0.0064
2872.8	0.0	0.0884	0.0375	0.0098	-0.0394	-0.0362	-0.0064
2872.8	0.0	0.0884	0.0378	0.0101	-0.0397	-0.0367	-0.0058
3835.2	-8.0	0.0857	0.0161	0.0128	-0.0721	-0.0407	0.0026
3835.2	-6.0	0.0856	0.0211	0.0123	-0.0643	-0.0388	0.0043
3840.0	-4.0	0.0860	0.0236	0.0110	-0.0546	-0.0373	0.0024
3792.1	-2.0	0.0869	0.0296	0.0114	-0.0478	-0.0371	0.0013
3835.2	0.0	0.0893	0.0334	0.0132	-0.0386	-0.0397	-0.0023
3830.4	0.0	0.0892	0.0330	0.0125	-0.0384	-0.0389	-0.0023
3830.4	0.0	0.0891	0.0338	0.0121	-0.0399	-0.0393	-0.0020
3820.8	2.0	0.0919	0.0378	0.0147	-0.0317	-0.0431	-0.0068
1910.4	0.0	0.0831	0.0447	0.0102	-0.0477	-0.0340	-0.0030
2863.2	0.0	0.0876	0.0379	0.0112	-0.0394	-0.0363	-0.0067
3849.6	0.0	0.0893	0.0326	0.0124	-0.0373	-0.0383	-0.0077

Run# 69

Dynamic Pressure (N/m ²)	Angle of Attack (deg)	D/q (m ²)	L/q (m ²)	SF/q (m ²)	PM/q (m ³)	YM/q (m ³)	RM/q (m ³)
1934.4	0.0	0.0832	0.0209	0.0085	-0.0466	-0.0348	-0.0061
2892.0	0.0	0.0852	0.0131	0.0102	-0.0383	-0.0380	-0.0083
3835.2	-8.0	0.0872	0.0073	0.0114	-0.0702	-0.0394	0.0011
3835.2	-6.0	0.0871	0.0078	0.0106	-0.0608	-0.0388	0.0023
3844.8	-4.0	0.0872	0.0098	0.0103	-0.0535	-0.0373	0.0021
3825.6	-2.0	0.0871	0.0109	0.0091	-0.0463	-0.0376	-0.0004
3825.6	0.0	0.0879	0.0126	0.0108	-0.0385	-0.0399	-0.0034
3816.0	2.0	0.0900	0.0138	0.0126	-0.0300	-0.0439	-0.0075
1939.1	0.0	0.0817	0.0216	0.0080	-0.0475	-0.0356	-0.0030
2896.7	0.0	0.0842	0.0129	0.0107	-0.0372	-0.0372	-0.0062
3830.4	0.0	0.0879	0.0117	0.0108	-0.0375	-0.0384	-0.0069

Run# 70

Dynamic Pressure (N/m ²)	Angle of Attack (deg)	D/q (m ²)	L/q (m ²)	SF/q (m ²)	PM/q (m ³)	YM/q (m ³)	RM/q (m ³)
1929.6	0.0	0.0878	0.0196	0.0069	-0.0440	-0.0361	-0.0057
2901.5	0.0	0.0909	0.0167	0.0071	-0.0417	-0.0382	-0.0065
3811.2	-8.0	0.0914	0.0090	0.0086	-0.0698	-0.0428	0.0006
3801.7	-6.0	0.0911	0.0104	0.0078	-0.0618	-0.0402	0.0012
3806.5	-4.0	0.0914	0.0113	0.0064	-0.0537	-0.0398	0.0002
3849.6	-2.0	0.0922	0.0133	0.0074	-0.0465	-0.0404	-0.0030
3840.0	0.0	0.0934	0.0160	0.0078	-0.0404	-0.0431	-0.0049
3811.2	2.0	0.0951	0.0168	0.0102	-0.0315	-0.0461	-0.0090
1929.6	0.0	0.0862	0.0228	0.0097	-0.0460	-0.0409	-0.0062
2887.2	0.0	0.0894	0.0166	0.0074	-0.0388	-0.0421	-0.0081
3835.2	0.0	0.0934	0.0162	0.0078	-0.0404	-0.0431	-0.0065

Run# 71

Dynamic Pressure (N/m ²)	Angle of Attack (deg)	D/q (m ²)	L/q (m ²)	SF/q (m ²)	PM/q (m ³)	YM/q (m ³)	RM/q (m ³)
1939.1	0.0	0.0879	0.0436	0.0083	-0.0445	-0.0336	-0.0051
1934.4	0.0	0.0878	0.0435	0.0076	-0.0439	-0.0343	-0.0056
1929.6	0.0	0.0881	0.0433	0.0074	-0.0434	-0.0357	-0.0056
2868.0	0.0	0.0900	0.0380	0.0082	-0.0369	-0.0374	-0.0073
3811.2	-8.0	0.0900	0.0211	0.0102	-0.0704	-0.0395	0.0002
3820.8	-6.0	0.0902	0.0257	0.0098	-0.0619	-0.0371	0.0018
3811.2	-4.0	0.0907	0.0299	0.0088	-0.0543	-0.0368	0.0014
3811.2	-2.0	0.0920	0.0341	0.0091	-0.0472	-0.0376	-0.0006
3840.0	0.0	0.0936	0.0373	0.0089	-0.0387	-0.0390	-0.0045
3849.6	2.0	0.0957	0.0419	0.0107	-0.0309	-0.0425	-0.0073

Run# 72

Dynamic Pressure (N/m ²)	Angle of Attack (deg)	D/q (m ²)	L/q (m ²)	SF/q (m ²)	PM/q (m ³)	YM/q (m ³)	RM/q (m ³)
1939.1	0.0	0.0775	0.0197	0.0083	-0.0443	-0.0342	-0.0076
2872.8	0.0	0.0802	0.0166	0.0081	-0.0398	-0.0376	-0.0079
3816.0	-8.0	0.0823	0.0091	0.0100	-0.0698	-0.0391	-0.0009
3820.8	-6.0	0.0815	0.0098	0.0083	-0.0608	-0.0369	0.0003
3796.9	-4.0	0.0819	0.0122	0.0060	-0.0543	-0.0366	-0.0007
3816.0	-2.0	0.0823	0.0128	0.0056	-0.0464	-0.0372	-0.0030
3792.1	0.0	0.0836	0.0150	0.0070	-0.0397	-0.0415	-0.0064
3787.3	2.0	0.0849	0.0155	0.0088	-0.0304	-0.0438	-0.0104
1939.1	0.0	0.0759	0.0202	0.0076	-0.0450	-0.0369	-0.0087
2863.2	0.0	0.0794	0.0174	0.0079	-0.0405	-0.0385	-0.0096
3835.2	0.0	0.0837	0.0147	0.0067	-0.0395	-0.0413	-0.0085

Run# 73

Dynamic Pressure (N/m ²)	Angle of Attack (deg)	D/q (m ²)	L/q (m ²)	SF/q (m ²)	PM/q (m ³)	YM/q (m ³)	RM/q (m ³)
1920.0	0.0	0.0711	0.0278	0.0051	-0.0475	-0.0343	-0.0040
1929.6	0.0	0.0710	0.0260	0.0053	-0.0458	-0.0355	-0.0050
1924.8	0.0	0.0709	0.0268	0.0072	-0.0465	-0.0345	-0.0052
3840.0	-8.0	0.0754	0.0068	0.0103	-0.0706	-0.0383	0.0005
3811.2	-6.0	0.0746	0.0106	0.0095	-0.0632	-0.0373	0.0024
3830.4	-4.0	0.0748	0.0146	0.0078	-0.0557	-0.0379	0.0011
3806.5	-2.0	0.0748	0.0171	0.0077	-0.0480	-0.0380	-0.0010
3787.3	0.0	0.0763	0.0204	0.0069	-0.0394	-0.0399	-0.0036
3854.3	2.0	0.0776	0.0217	0.0103	-0.0296	-0.0414	-0.0091
3854.3	0.0	0.0764	0.0201	0.0068	-0.0386	-0.0390	-0.0081

Run# 74

Dynamic Pressure (N/m ²)	Angle of Attack (deg)	D/q (m ²)	L/q (m ²)	SF/q (m ²)	PM/q (m ³)	YM/q (m ³)	RM/q (m ³)
1924.8	0.0	0.0703	0.0275	0.0074	-0.0473	-0.0348	-0.0034
2906.3	0.0	0.0722	0.0217	0.0077	-0.0390	-0.0365	-0.0072
3854.3	-8.0	0.0750	0.0065	0.0105	-0.0702	-0.0378	0.0023
3840.0	-6.0	0.0743	0.0104	0.0097	-0.0625	-0.0370	0.0034
3844.8	-4.0	0.0742	0.0128	0.0098	-0.0542	-0.0367	0.0015
3816.0	-2.0	0.0743	0.0180	0.0086	-0.0483	-0.0366	0.0006
3811.2	0.0	0.0760	0.0191	0.0097	-0.0379	-0.0404	-0.0029
3835.2	2.0	0.0775	0.0212	0.0113	-0.0295	-0.0427	-0.0071

Run# 75

Dynamic Pressure (N/m ²)	Angle of Attack (deg)	D/q (m ²)	L/q (m ²)	SF/q (m ²)	PM/q (m ³)	YM/q (m ³)	RM/q (m ³)
1905.6	0.0	0.0833	0.0394	0.0105	-0.0433	-0.0347	-0.0055
1886.5	0.0	0.0835	0.0410	0.0108	-0.0450	-0.0357	-0.0055
2858.4	0.0	0.0861	0.0355	0.0110	-0.0380	-0.0378	-0.0067
3825.6	-8.0	0.0856	0.0195	0.0120	-0.0665	-0.0383	-0.0004
3854.3	-6.0	0.0856	0.0231	0.0110	-0.0581	-0.0361	-0.0002
3859.1	-4.0	0.0863	0.0260	0.0091	-0.0513	-0.0362	-0.0012
3816.0	-4.0	0.0859	0.0256	0.0111	-0.0506	-0.0366	-0.0016
3816.0	-2.0	0.0873	0.0301	0.0097	-0.0435	-0.0379	-0.0029
3820.8	0.0	0.0892	0.0334	0.0122	-0.0359	-0.0399	-0.0064
3825.6	2.0	0.0912	0.0376	0.0134	-0.0291	-0.0424	-0.0102
1924.8	0.0	0.0807	0.0418	0.0113	-0.0457	-0.0350	-0.0086
2872.8	0.0	0.0847	0.0344	0.0110	-0.0363	-0.0371	-0.0101
3854.3	-8.0	0.0855	0.0204	0.0112	-0.0676	-0.0393	-0.0008
3844.8	-6.0	0.0854	0.0237	0.0112	-0.0587	-0.0368	-0.0004
3854.3	-4.0	0.0860	0.0265	0.0102	-0.0517	-0.0370	-0.0013
3849.6	-2.0	0.0870	0.0305	0.0102	-0.0443	-0.0378	-0.0034
3844.8	0.0	0.0886	0.0332	0.0118	-0.0353	-0.0397	-0.0075
3844.8	2.0	0.0908	0.0373	0.0133	-0.0283	-0.0438	-0.0110

Run# 76

Dynamic Pressure (N/m ²)	Angle of Attack (deg)	D/q (m ²)	L/q (m ²)	SF/q (m ²)	PM/q (m ³)	YM/q (m ³)	RM/q (m ³)
1905.6	0.0	0.0801	0.0191	0.0133	-0.0408	-0.0343	-0.0088
2872.8	0.0	0.0830	0.0173	0.0144	-0.0392	-0.0384	-0.0074
3849.6	-8.0	0.0849	0.0090	0.0119	-0.0670	-0.0372	0.0003
3830.4	-6.0	0.0845	0.0101	0.0122	-0.0595	-0.0364	0.0008
3820.8	-4.0	0.0845	0.0114	0.0113	-0.0520	-0.0363	-0.0003
3801.7	-2.0	0.0848	0.0129	0.0109	-0.0440	-0.0387	-0.0029
3811.2	0.0	0.0859	0.0140	0.0128	-0.0357	-0.0399	-0.0061
3806.5	2.0	0.0879	0.0169	0.0169	-0.0300	-0.0421	-0.0105

Run# 77

Dynamic Pressure (N/m ²)	Angle of Attack (deg)	D/q (m ²)	L/q (m ²)	SF/q (m ²)	PM/q (m ³)	YM/q (m ³)	RM/q (m ³)
1924.8	0.0	0.0816	0.0196	0.0118	-0.0414	-0.0361	-0.0081
2853.6	0.0	0.0815	0.0170	0.0129	-0.0397	-0.0370	-0.0069
3825.6	-8.0	0.0837	0.0063	0.0127	-0.0660	-0.0379	-0.0008
3816.0	-6.0	0.0832	0.0080	0.0121	-0.0571	-0.0370	-0.0028
3811.2	-4.0	0.0834	0.0092	0.0112	-0.0503	-0.0359	-0.0029
3811.2	-2.0	0.0836	0.0112	0.0116	-0.0433	-0.0370	-0.0042
3849.6	0.0	0.0848	0.0143	0.0132	-0.0380	-0.0401	-0.0063
3835.2	2.0	0.0869	0.0170	0.0158	-0.0324	-0.0431	-0.0098

Run# 78

Dynamic Pressure (N/m ²)	Angle of Attack (deg)	D/q (m ²)	L/q (m ²)	SF/q (m ²)	PM/q (m ³)	YM/q (m ³)	RM/q (m ³)
1910.4	0.0	0.0815	0.0393	0.0107	-0.0435	-0.0354	-0.0067
1910.4	0.0	0.0815	0.0398	0.0114	-0.0439	-0.0352	-0.0072
1915.2	0.0	0.0815	0.0393	0.0109	-0.0430	-0.0351	-0.0071
2892.0	0.0	0.0823	0.0343	0.0102	-0.0398	-0.0364	-0.0065
2887.2	0.0	0.0826	0.0345	0.0106	-0.0395	-0.0366	-0.0067
2882.4	0.0	0.0823	0.0343	0.0088	-0.0397	-0.0374	-0.0060
3816.0	-8.0	0.0819	0.0143	0.0121	-0.0672	-0.0375	0.0014
3816.0	-6.0	0.0819	0.0196	0.0106	-0.0593	-0.0365	0.0014
3801.7	-4.0	0.0825	0.0227	0.0094	-0.0509	-0.0359	-0.0003
3844.8	-2.0	0.0835	0.0273	0.0099	-0.0449	-0.0366	-0.0020
3835.2	0.0	0.0854	0.0317	0.0119	-0.0350	-0.0395	-0.0072
3825.6	0.0	0.0852	0.0321	0.0110	-0.0355	-0.0408	-0.0065
3825.6	0.0	0.0851	0.0322	0.0110	-0.0364	-0.0396	-0.0061
3811.2	2.0	0.0877	0.0362	0.0154	-0.0309	-0.0427	-0.0100

Run# 79

Dynamic Pressure (N/m ²)	Angle of Attack (deg)	D/q (m ²)	L/q (m ²)	SF/q (m ²)	PM/q (m ³)	YM/q (m ³)	RM/q (m ³)
1920.0	0.0	0.0811	0.0412	0.0104	-0.0465	-0.0350	-0.0048
1924.8	0.0	0.0813	0.0416	0.0106	-0.0465	-0.0343	-0.0052
1924.8	0.0	0.0816	0.0421	0.0113	-0.0462	-0.0341	-0.0047
2882.4	0.0	0.0818	0.0346	0.0096	-0.0404	-0.0368	-0.0060
3830.4	-2.0	0.0837	0.0282	0.0093	-0.0454	-0.0367	-0.0032
3825.6	0.0	0.0850	0.0324	0.0110	-0.0385	-0.0396	-0.0034

Run# 80

Dynamic Pressure (N/m ²)	Angle of Attack (deg)	D/q (m ²)	L/q (m ²)	SF/q (m ²)	PM/q (m ³)	YM/q (m ³)	RM/q (m ³)
1900.8	0.0	0.0796	0.0211	0.0122	-0.0450	-0.0363	-0.0063
2896.7	0.0	0.0823	0.0149	0.0111	-0.0364	-0.0390	-0.0061
3830.4	-3.0	0.0840	0.0075	0.0120	-0.0654	-0.0380	-0.0008
3849.6	-6.0	0.0839	0.0081	0.0117	-0.0570	-0.0376	-0.0004
3844.8	-4.0	0.0839	0.0094	0.0126	-0.0489	-0.0368	-0.0015
3849.6	-2.0	0.0839	0.0112	0.0102	-0.0419	-0.0371	-0.0036
3825.6	0.0	0.0858	0.0127	0.0138	-0.0325	-0.0409	-0.0075
3806.5	2.0	0.0872	0.0155	0.0153	-0.0280	-0.0447	-0.0097

Run# 81

Dynamic Pressure (N/m ²)	Angle of Attack (deg)	D/q (m ²)	L/q (m ²)	SF/q (m ²)	PM/q (m ³)	YM/q (m ³)	RM/q (m ³)
1939.1	0.0	0.0810	0.0413	0.0115	-0.0463	-0.0356	-0.0052
2892.0	0.0	0.0831	0.0320	0.0097	-0.0329	-0.0361	-0.0076
3840.0	-8.0	0.0829	0.0199	0.0117	-0.0688	-0.0383	0.0010
3811.2	-6.0	0.0831	0.0226	0.0106	-0.0583	-0.0366	0.0014
3816.0	-4.0	0.0839	0.0260	0.0108	-0.0506	-0.0359	0.0001
3840.0	-2.0	0.0847	0.0298	0.0102	-0.0435	-0.0372	-0.0014
3830.4	0.0	0.0862	0.0323	0.0118	-0.0341	-0.0391	-0.0058
3820.8	0.0	0.0860	0.0324	0.0118	-0.0343	-0.0390	-0.0049
3825.6	0.0	0.0860	0.0328	0.0119	-0.0347	-0.0386	-0.0049
3811.2	2.0	0.0892	0.0373	0.0131	-0.0289	-0.0418	-0.0090

Run# 82

Dynamic Pressure (N/m ²)	Angle of Attack (deg)	D/q (m ²)	L/q (m ²)	SF/q (m ²)	PM/q (m ³)	YM/q (m ³)	RM/q (m ³)
1915.2	0.0	0.0813	0.0406	0.0116	-0.0447	-0.0361	-0.0054
2868.0	0.0	0.0833	0.0329	0.0109	-0.0327	-0.0375	-0.0070
3811.2	-8.0	0.0836	0.0198	0.0120	-0.0712	-0.0366	-0.0018
3820.8	-8.0	0.0837	0.0194	0.0123	-0.0699	-0.0372	-0.0020
3820.8	-8.0	0.0837	0.0201	0.0119	-0.0706	-0.0373	-0.0013
3820.8	-6.0	0.0835	0.0218	0.0118	-0.0598	-0.0354	-0.0013
3811.2	-4.0	0.0844	0.0251	0.0114	-0.0520	-0.0349	-0.0012
3830.4	-2.0	0.0848	0.0286	0.0096	-0.0445	-0.0365	-0.0027
3792.1	0.0	0.0862	0.0334	0.0117	-0.0377	-0.0375	-0.0049
3835.2	2.0	0.0893	0.0367	0.0145	-0.0298	-0.0405	-0.0104
1905.6	0.0	0.0784	0.0371	0.0112	-0.0411	-0.0317	-0.0139
2868.0	0.0	0.0819	0.0306	0.0105	-0.0329	-0.0343	-0.0116
3811.2	0.0	0.0859	0.0336	0.0102	-0.0377	-0.0366	-0.0095

Run# 83

Dynamic Pressure (N/m ²)	Angle of Attack (deg)	D/q (m ²)	L/q (m ²)	SF/q (m ²)	PM/q (m ³)	YM/q (m ³)	RM/q (m ³)
1934.4	0.0	0.0770	0.0214	0.0138	-0.0444	-0.0395	-0.0008
2872.8	0.0	0.0807	0.0141	0.0133	-0.0342	-0.0400	-0.0039
3844.8	-8.0	0.0834	0.0095	0.0138	-0.0687	-0.0402	0.0050
3830.4	-6.0	0.0830	0.0098	0.0118	-0.0594	-0.0394	0.0059
3840.0	-4.0	0.0831	0.0103	0.0131	-0.0502	-0.0388	0.0043
3830.4	-2.0	0.0833	0.0129	0.0122	-0.0446	-0.0395	0.0029
3835.2	0.0	0.0837	0.0155	0.0129	-0.0381	-0.0419	-0.0001
3811.2	2.0	0.0863	0.0170	0.0175	-0.0305	-0.0466	-0.0050
3854.3	0.0	0.0834	0.0145	0.0141	-0.0365	-0.0423	-0.0015
2911.1	0.0	0.0799	0.0134	0.0144	-0.0332	-0.0405	-0.0008
1924.8	0.0	0.0772	0.0217	0.0134	-0.0461	-0.0409	0.0057

Run# 84

Dynamic Pressure (N/m ²)	Angle of Attack (deg)	D/q (m ²)	L/q (m ²)	SF/q (m ²)	PM/q (m ³)	YM/q (m ³)	RM/q (m ³)
1910.4	0.0	0.0829	0.0417	0.0105	-0.0423	-0.0334	-0.0052
2872.8	0.0	0.0845	0.0324	0.0111	-0.0304	-0.0354	-0.0071
3830.4	-8.0	0.0855	0.0218	0.0129	-0.0676	-0.0369	-0.0022
3816.0	-6.0	0.0853	0.0245	0.0110	-0.0589	-0.0363	-0.0001
3816.0	-4.0	0.0856	0.0273	0.0106	-0.0501	-0.0358	-0.0011
3816.0	-2.0	0.0864	0.0309	0.0105	-0.0419	-0.0355	-0.0034
3820.8	0.0	0.0878	0.0348	0.0133	-0.0342	-0.0382	-0.0057
3835.2	2.0	0.0906	0.0393	0.0137	-0.0287	-0.0418	-0.0101
3811.2	0.0	0.0875	0.0355	0.0113	-0.0355	-0.0379	-0.0083
2839.3	0.0	0.0833	0.0321	0.0111	-0.0295	-0.0359	-0.0113
1929.6	0.0	0.0809	0.0420	0.0118	-0.0438	-0.0341	-0.0094

Run# 85

Dynamic Pressure (N/m ²)	Angle of Attack (deg)	D/q (m ²)	L/q (m ²)	SF/q (m ²)	PM/q (m ³)	YM/q (m ³)	RM/q (m ³)
1924.8	0.0	0.0804	0.0229	0.0120	-0.0461	-0.0344	-0.0060
2868.0	0.0	0.0827	0.0140	0.0118	-0.0333	-0.0376	-0.0071
3806.5	-8.0	0.0845	0.0082	0.0127	-0.0655	-0.0378	-0.0002
3792.1	-6.0	0.0841	0.0094	0.0117	-0.0570	-0.0377	0.0012
3825.6	-4.0	0.0844	0.0099	0.0126	-0.0488	-0.0358	-0.0006
3849.6	-2.0	0.0848	0.0120	0.0116	-0.0423	-0.0378	-0.0015
3844.8	0.0	0.0856	0.0150	0.0139	-0.0375	-0.0405	-0.0042
3811.2	2.0	0.0872	0.0174	0.0152	-0.0303	-0.0439	-0.0078

Run# 86

Dynamic Pressure (N/m ²)	Angle of Attack (deg)	D/q (m ²)	L/q (m ²)	SF/q (m ²)	PM/q (m ³)	YM/q (m ³)	RM/q (m ³)
1953.5	0.0	0.0692	0.0250	0.0116	-0.0460	-0.0339	-0.0055
2877.6	0.0	0.0711	0.0193	0.0114	-0.0375	-0.0361	-0.0059
3854.3	-8.0	0.0744	0.0042	0.0134	-0.0674	-0.0375	0.0021
3825.6	-6.0	0.0735	0.0063	0.0127	-0.0576	-0.0353	0.0030
3820.8	-4.0	0.0733	0.0095	0.0116	-0.0501	-0.0379	0.0026
3844.8	-2.0	0.0732	0.0134	0.0110	-0.0432	-0.0360	0.0006
3840.0	0.0	0.0744	0.0175	0.0114	-0.0369	-0.0387	-0.0023
3830.4	2.0	0.0764	0.0217	0.0145	-0.0316	-0.0424	-0.0060

Run# 87

Dynamic Pressure (N/m ²)	Angle of Attack (deg)	D/q (m ²)	L/q (m ²)	SF/q (m ²)	PM/q (m ³)	YM/q (m ³)	RM/q (m ³)
1934.4	0.0	0.0731	0.0264	0.0053	-0.0406	-0.0324	-0.0060
1939.1	0.0	0.0729	0.0262	0.0046	-0.0403	-0.0328	-0.0061
1943.9	0.0	0.0728	0.0261	0.0039	-0.0402	-0.0317	-0.0058
2882.4	0.0	0.0762	0.0193	0.0090	-0.0327	-0.0360	-0.0078
3840.0	-8.0	0.0778	0.0056	0.0090	-0.0658	-0.0377	0.0000
3830.4	-8.0	0.0778	0.0055	0.0093	-0.0658	-0.0379	0.0000
3844.8	-8.0	0.0780	0.0056	0.0090	-0.0662	-0.0384	0.0004
3820.8	-6.0	0.0779	0.0102	0.0064	-0.0580	-0.0367	0.0010
3816.0	-4.0	0.0777	0.0127	0.0050	-0.0501	-0.0353	-0.0007
3806.5	-2.0	0.0777	0.0154	0.0061	-0.0431	-0.0360	-0.0028
3811.2	0.0	0.0796	0.0174	0.0104	-0.0352	-0.0384	-0.0064
3830.4	2.0	0.0818	0.0206	0.0123	-0.0311	-0.0423	-0.0101
3840.0	2.0	0.0819	0.0207	0.0122	-0.0307	-0.0414	-0.0102
3816.0	2.0	0.0817	0.0204	0.0133	-0.0296	-0.0423	-0.0106
3873.5	0.0	0.0788	0.0178	0.0093	-0.0360	-0.0385	-0.0077
2868.0	0.0	0.0740	0.0199	0.0074	-0.0333	-0.0360	-0.0105
1929.6	0.0	0.0705	0.0281	0.0101	-0.0434	-0.0340	-0.0103
2877.6	0.0	0.0747	0.0199	0.0080	-0.0339	-0.0348	-0.0105
3840.0	0.0	0.0795	0.0182	0.0107	-0.0347	-0.0390	-0.0103

Run# 88

Dynamic Pressure (N/m ²)	Angle of Attack (deg)	D/q (m ²)	L/q (m ²)	SF/q (m ²)	PM/q (m ³)	YM/q (m ³)	RM/q (m ³)
1943.9	0.0	0.0771	0.0174	0.0096	-0.0420	-0.0354	-0.0086
2872.8	0.0	0.0799	0.0129	0.0090	-0.0353	-0.0379	-0.0077
3806.5	-8.0	0.0820	0.0069	0.0103	-0.0665	-0.0394	0.0018
3792.1	-6.0	0.0816	0.0069	0.0094	-0.0562	-0.0384	0.0023
3849.6	-4.0	0.0815	0.0079	0.0091	-0.0485	-0.0389	0.0009
3835.2	-2.0	0.0815	0.0100	0.0088	-0.0424	-0.0389	-0.0011
3825.6	0.0	0.0826	0.0122	0.0102	-0.0361	-0.0411	-0.0040
3816.0	2.0	0.0846	0.0143	0.0131	-0.0296	-0.0438	-0.0076

Run# 89

Dynamic Pressure (N/m ²)	Angle of Attack (deg)	D/q (m ²)	L/q (m ²)	SF/q (m ²)	PM/q (m ³)	YM/q (m ³)	RM/q (m ³)
1924.8	0.0	0.0714	0.0250	0.0069	-0.0437	-0.0346	-0.0068
2911.1	0.0	0.0737	0.0174	0.0090	-0.0347	-0.0362	-0.0073
3844.8	-8.0	0.0768	0.0047	0.0118	-0.0671	-0.0383	0.0010
3840.0	-6.0	0.0762	0.0070	0.0111	-0.0568	-0.0367	0.0008
3811.2	-4.0	0.0761	0.0102	0.0100	-0.0496	-0.0362	-0.0006
3792.1	-2.0	0.0761	0.0137	0.0087	-0.0426	-0.0366	-0.0030
3811.2	0.0	0.0778	0.0170	0.0102	-0.0366	-0.0402	-0.0062
3787.3	2.0	0.0803	0.0201	0.0154	-0.0305	-0.0434	-0.0107

Run# 90

Dynamic Pressure (N/m ²)	Angle of Attack (deg)	D/q (m ²)	L/q (m ²)	SF/q (m ²)	PM/q (m ³)	YM/q (m ³)	RM/q (m ³)
1934.4	0.0	0.0713	0.0320	0.0108	-0.0430	-0.0353	-0.0065
2896.7	0.0	0.0736	0.0253	0.0115	-0.0344	-0.0365	-0.0067
3835.2	-8.0	0.0764	-0.0037	0.0146	-0.0666	-0.0388	0.0025
3830.4	-8.0	0.0753	0.0038	0.0131	-0.0575	-0.0392	0.0038
3811.2	-4.0	0.0746	0.0097	0.0141	-0.0478	-0.0365	0.0010
3811.2	-2.0	0.0748	0.0169	0.0120	-0.0424	-0.0385	0.0005
3859.1	0.0	0.0765	0.0247	0.0120	-0.0370	-0.0410	-0.0025
3840.0	2.0	0.0790	0.0327	0.0166	-0.0289	-0.0441	-0.0079

Run# 91

Dynamic Pressure (N/m ²)	Angle of Attack (deg)	D/q (m ²)	L/q (m ²)	SF/q (m ²)	PM/q (m ³)	YM/q (m ³)	RM/q (m ³)
1910.4	0.0	0.0706	0.0319	0.0133	-0.0460	-0.0348	-0.0050
2877.6	0.0	0.0723	0.0244	0.0104	-0.0361	-0.0364	-0.0060
3820.8	-8.0	0.0757	-0.0005	0.0125	-0.0661	-0.0383	0.0011
3796.9	-8.0	0.0744	0.0043	0.0130	-0.0560	-0.0368	0.0018
3835.2	-4.0	0.0743	0.0103	0.0121	-0.0495	-0.0367	0.0013
3825.6	-2.0	0.0741	0.0158	0.0091	-0.0419	-0.0371	-0.0006
3816.0	0.0	0.0752	0.0220	0.0103	-0.0343	-0.0389	-0.0045
3830.4	2.0	0.0778	0.0267	0.0152	-0.0276	-0.0417	-0.0090

Run# 92

Dynamic Pressure (N/m ²)	Angle of Attack (deg)	D/q (m ²)	L/q (m ²)	SF/q (m ²)	PM/q (m ³)	YM/q (m ³)	RM/q (m ³)
1915.2	0.0	0.0708	0.0137	0.0086	-0.0411	-0.0356	-0.0082
2829.7	0.0	0.0731	0.0082	0.0091	-0.0335	-0.0374	-0.0083
3830.4	-8.0	0.0755	-0.0010	0.0108	-0.0620	-0.0379	-0.0003
3830.4	-6.0	0.0750	0.0013	0.0096	-0.0548	-0.0377	0.0017
3825.6	-4.0	0.0751	0.0042	0.0095	-0.0488	-0.0374	0.0017
3840.0	-2.0	0.0751	0.0060	0.0081	-0.0423	-0.0374	-0.0003
3835.2	0.0	0.0760	0.0087	0.0092	-0.0361	-0.0384	-0.0032
3825.6	0.0	0.0758	0.0092	0.0086	-0.0358	-0.0403	-0.0028
3835.2	0.0	0.0762	0.0088	0.0094	-0.0356	-0.0394	-0.0038
3825.6	2.0	0.0780	0.0116	0.0134	-0.0302	-0.0419	-0.0078
3787.3	0.0	0.0752	0.0092	0.0081	-0.0367	-0.0388	-0.0068
2877.6	0.0	0.0714	0.0070	0.0096	-0.0309	-0.0357	-0.0085
1896.0	0.0	0.0692	0.0134	0.0087	-0.0398	-0.0358	-0.0086
2853.6	0.0	0.0719	0.0070	0.0097	-0.0311	-0.0371	-0.0083
3825.6	0.0	0.0762	0.0097	0.0078	-0.0366	-0.0395	-0.0070

Run# 93

Dynamic Pressure (N/m ²)	Angle of Attack (deg)	D/q (m ²)	L/q (m ²)	SF/q (m ²)	PM/q (m ³)	YM/q (m ³)	RM/q (m ³)
1939.1	0.0	0.0757	0.0227	0.0025	-0.0351	-0.0343	-0.0083
2868.0	0.0	0.0785	0.0197	0.0017	-0.0344	-0.0376	-0.0076
3868.7	-8.0	0.0803	0.0032	0.0053	-0.0604	-0.0416	0.0019
3859.1	-6.0	0.0796	0.0068	0.0054	-0.0523	-0.0378	0.0022
3859.1	-4.0	0.0799	0.0108	0.0033	-0.0468	-0.0380	0.0018
3854.3	-2.0	0.0804	0.0138	0.0023	-0.0393	-0.0367	0.0012
3835.2	0.0	0.0818	0.0166	0.0041	-0.0314	-0.0396	-0.0043
3806.5	2.0	0.0845	0.0208	0.0079	-0.0258	-0.0432	-0.0085
3849.6	0.0	0.0812	0.0177	0.0039	-0.0333	-0.0398	-0.0050
2868.0	0.0	0.0766	0.0178	0.0037	-0.0306	-0.0372	-0.0043
1953.5	0.0	0.0733	0.0237	0.0039	-0.0361	-0.0355	-0.0026

Run# 94

Dynamic Pressure (N/m ²)	Angle of Attack (deg)	D/q (m ²)	L/q (m ²)	SF/q (m ²)	PM/q (m ³)	YM/q (m ³)	RM/q (m ³)
1896.0	0.0	0.0732	0.0077	0.0021	-0.0364	-0.0354	-0.0085
2892.0	0.0	0.0764	0.0054	0.0046	-0.0331	-0.0385	-0.0091
3840.0	-8.0	0.0787	-0.010	0.0063	-0.0626	-0.0394	-0.0030
3844.8	-6.0	0.0777	0.0009	0.0039	-0.0552	-0.0373	-0.0007
3820.8	-4.0	0.0777	0.0024	0.0045	-0.0488	-0.0365	-0.0015
3835.2	-2.0	0.0772	0.0039	0.0031	-0.0423	-0.0374	-0.0034
3840.0	0.0	0.0788	0.0051	0.0054	-0.0343	-0.0409	-0.0068
3830.4	2.0	0.0805	0.0060	0.0062	-0.0279	-0.0439	-0.0107

Run# 95

Dynamic Pressure (N/m ²)	Angle of Attack (deg)	D/q (m ²)	L/q (m ²)	SF/q (m ²)	PM/q (m ³)	YM/q (m ³)	RM/q (m ³)
1924.8	0.0	0.0728	0.0116	0.0058	-0.0444	-0.0354	-0.0081
2887.2	0.0	0.0746	0.0042	0.0066	-0.0333	-0.0377	-0.0087
3816.0	-8.0	0.0788	-0.0008	0.0119	-0.0614	-0.0396	0.0004
3816.0	-8.0	0.0789	-0.0001	0.0171	-0.0625	-0.0393	0.0008
3811.2	-8.0	0.0790	-0.0005	0.0181	-0.0623	-0.0380	0.0005
3816.0	-6.0	0.0775	0.0009	0.0193	-0.0546	-0.0369	0.0017
3820.8	-4.0	0.0770	0.0023	0.0180	-0.0489	-0.0373	0.0014
3806.5	-2.0	0.0765	0.0034	0.0067	-0.0423	-0.0375	-0.0014
3787.3	0.0	0.0767	0.0045	0.0072	-0.0348	-0.0398	-0.0047
3840.0	2.0	0.0787	0.0060	0.0105	-0.0298	-0.0431	-0.0078

Run# 96

Dynamic Pressure (N/m ²)	Angle of Attack (deg)	D/q (m ²)	L/q (m ²)	SF/q (m ²)	PM/q (m ³)	YM/q (m ³)	RM/q (m ³)
1896.0	0.0	0.0847	0.0514	0.0106	-0.0556	-0.0356	-0.0040
2858.4	0.0	0.0864	0.0409	0.0092	-0.0409	-0.0374	-0.0053
3801.7	-8.0	0.0878	0.0252	0.0099	-0.0728	-0.0402	0.0008
3796.9	-6.0	0.0867	0.0289	0.0105	-0.0642	-0.0380	0.0012
3844.8	-4.0	0.0871	0.0324	0.0095	-0.0567	-0.0367	0.0010
3820.8	-2.0	0.0873	0.0366	0.0091	-0.0486	-0.0379	0.0001
3820.8	0.0	0.0892	0.0412	0.0099	-0.0425	-0.0400	-0.0028
3820.8	2.0	0.0915	0.0455	0.0132	-0.0367	-0.0434	-0.0070

Run# 97

Dynamic Pressure (N/m ²)	Angle of Attack (deg)	D/q (m ²)	L/q (m ²)	SF/q (m ²)	PM/q (m ³)	YM/q (m ³)	RM/q (m ³)
1924.8	0.0	0.0823	0.0257	0.0095	-0.0489	-0.0351	-0.0051
2887.2	0.0	0.0850	0.0205	0.0111	-0.0420	-0.0367	-0.0058
3806.5	-8.0	0.0862	0.0111	0.0110	-0.0712	-0.0380	0.0008
3806.5	-6.0	0.0857	0.0122	0.0099	-0.0625	-0.0371	0.0023
3820.8	-4.0	0.0858	0.0142	0.0101	-0.0552	-0.0369	0.0022
3859.1	-2.0	0.0856	0.0154	0.0100	-0.0475	-0.0372	0.0007
3801.7	0.0	0.0871	0.0200	0.0118	-0.0440	-0.0391	-0.0009
3835.2	2.0	0.0888	0.0217	0.0142	-0.0367	-0.0435	-0.0052

Run# 98

Dynamic Pressure (N/m ²)	Angle of Attack (deg)	D/q (m ²)	L/q (m ²)	SF/q (m ²)	PM/q (m ³)	YM/q (m ³)	RM/q (m ³)
1924.8	0.0	0.0841	0.0238	3.3766	-0.0457	-4.4147	-1.1376
2858.4	0.0	0.0867	0.0204	2.2759	-0.0424	-2.9857	-0.7672
3825.6	-8.0	0.0887	0.0102	1.7033	-0.0699	-2.3087	-0.3441
3835.2	-6.0	0.0877	0.0106	1.6977	-0.0608	-2.2883	-0.3889
3835.2	-4.0	0.0877	0.0118	1.6970	-0.0522	-2.2722	-0.4555
3830.4	-2.0	0.0877	0.0137	1.6988	-0.0444	-2.2580	-0.5134
3849.6	0.0	0.0891	0.0183	1.6928	-0.0415	-2.2292	-0.5680
3849.6	2.0	0.0907	0.0199	1.6941	-0.0335	-2.2119	-0.6268

Run# 99

Dynamic Pressure (N/m ²)	Angle of Attack (deg)	D/q (m ²)	L/q (m ²)	SF/q (m ²)	PM/q (m ³)	YM/q (m ³)	RM/q (m ³)
1905.8	0.0	0.0836	0.0427	0.0103	-0.0456	-0.0340	-0.0061
2834.5	0.0	0.0863	0.0408	0.0116	-0.0431	-0.0367	-0.0061
3835.2	-8.0	0.0881	0.0217	0.0115	-0.0704	-0.0374	-0.0001
3825.6	-6.0	0.0874	0.0244	0.0113	-0.0606	-0.0377	0.0009
3830.4	-4.0	0.0878	0.0287	0.0102	-0.0530	-0.0361	0.0011
3830.4	-2.0	0.0878	0.0330	0.0101	-0.0454	-0.0377	-0.0003
3825.6	0.0	0.0894	0.0387	0.0121	-0.0416	-0.0387	-0.0028
3835.2	2.0	0.0919	0.0431	0.0137	-0.0342	-0.0421	-0.0072

Run# 100

Dynamic Pressure (N/m ²)	Angle of Attack (deg)	D/q (m ²)	L/q (m ²)	SF/q (m ²)	PM/q (m ³)	YM/q (m ³)	RM/q (m ³)
1939.1	0.0	0.0807	0.0401	0.0096	-0.0476	-0.0344	-0.0050
1934.4	0.0	0.0807	0.0402	0.0103	-0.0473	-0.0347	-0.0056
1934.4	0.0	0.0807	0.0402	0.0097	-0.0481	-0.0345	-0.0047
2887.2	0.0	0.0841	0.0342	0.0105	-0.0420	-0.0373	-0.0055
3835.2	-8.0	0.0844	0.0140	0.0136	-0.0685	-0.0388	0.0018
3840.0	-6.0	0.0838	0.0182	0.0125	-0.0604	-0.0375	0.0028
3830.4	-4.0	0.0837	0.0219	0.0116	-0.0541	-0.0364	0.0016
3830.4	-2.0	0.0842	0.0265	0.0117	-0.0477	-0.0383	0.0010
3840.0	0.0	0.0854	0.0294	0.0130	-0.0383	-0.0398	-0.0029
3835.2	0.0	0.0852	0.0296	0.0130	-0.0387	-0.0400	-0.0029
3835.2	0.0	0.0852	0.0291	0.0124	-0.0382	-0.0403	-0.0026
3816.0	2.0	0.0877	0.0343	0.0167	-0.0328	-0.0440	-0.0070
3859.1	0.0	0.0851	0.0293	0.0141	-0.0379	-0.0400	-0.0061
2877.6	0.0	0.0821	0.0322	0.0087	-0.0371	-0.0371	-0.0053
1939.1	0.0	0.0785	0.0408	0.0087	-0.0479	-0.0353	-0.0001
2858.4	0.0	0.0831	0.0328	0.0110	-0.0374	-0.0375	-0.0051
3825.6	0.0	0.0856	0.0301	0.0138	-0.0381	-0.0409	-0.0056

Run# 101

Dynamic Pressure (N/m ²)	Angle of Attack (deg)	D/q (m ²)	L/q (m ²)	SF/q (m ²)	PM/q (m ³)	YM/q (m ³)	RM/q (m ³)
1929.6	0.0	0.0809	0.0235	0.0092	-0.0490	-0.0357	-0.0049
2877.6	0.0	0.0841	0.0162	0.0104	-0.0388	-0.0376	-0.0080
3830.4	-8.0	0.0856	0.0075	0.0134	-0.0680	-0.0384	0.0003
3830.4	-6.0	0.0850	0.0100	0.0118	-0.0618	-0.0372	0.0019
3811.2	-4.0	0.0851	0.0121	0.0113	-0.0561	-0.0363	0.0010
3816.0	-2.0	0.0849	0.0146	0.0110	-0.0493	-0.0377	-0.0005
3816.0	0.0	0.0859	0.0150	0.0129	-0.0401	-0.0403	-0.0047
3811.2	2.0	0.0879	0.0181	0.0163	-0.0349	-0.0439	-0.0087

Run# 102

Dynamic Pressure (N/m ²)	Angle of Attack (deg)	D/q (m ²)	L/q (m ²)	SF/q (m ²)	PM/q (m ³)	YM/q (m ³)	RM/q (m ³)
1924.8	0.0	0.0890	0.0257	0.0012	-0.0491	-0.0356	-0.0040
2868.0	0.0	0.0920	0.0191	0.0020	-0.0410	-0.0374	-0.0069
3816.0	-8.0	0.0851	0.0133	0.0077	-0.0751	-0.0394	-0.0018
3801.7	-6.0	0.0959	0.0164	0.0077	-0.0683	-0.0370	0.0003
3811.2	-4.0	0.0855	0.0174	0.0048	-0.0802	-0.0372	-0.0007
3816.0	-2.0	0.0862	0.0196	0.0071	-0.0526	-0.0373	-0.0033
3820.8	0.0	0.0976	0.0210	0.0083	-0.0449	-0.0397	-0.0055
3806.5	2.0	0.0986	0.0221	0.0109	-0.0366	-0.0426	-0.0094

Run# 103

Dynamic Pressure (N/m ²)	Angle of Attack (deg)	D/q (m ²)	L/q (m ²)	SF/q (m ²)	PM/q (m ³)	YM/q (m ³)	RM/q (m ³)
1915.2	0.0	0.0885	0.0483	0.0019	-0.0500	-0.0337	-0.0038
2863.2	0.0	0.0926	0.0412	0.0067	-0.0419	-0.0349	-0.0061
3825.6	-8.0	0.0934	0.0223	0.0088	-0.0756	-0.0381	-0.0011
3820.8	-6.0	0.0922	0.0267	0.0063	-0.0671	-0.0384	0.0016
3835.2	-4.0	0.0938	0.0317	0.0089	-0.0598	-0.0363	0.0008
3830.4	-2.0	0.0942	0.0367	0.0080	-0.0528	-0.0361	-0.0002
3820.8	0.0	0.0959	0.0397	0.0098	-0.0426	-0.0382	-0.0038
3820.8	2.0	0.0977	0.0438	0.0116	-0.0347	-0.0418	-0.0079

Run# 104

Dynamic Pressure (N/m ²)	Angle of Attack (deg)	D/q (m ²)	L/q (m ²)	SF/q (m ²)	PM/q (m ³)	YM/q (m ³)	RM/q (m ³)
1915.2	0.0	0.0887	0.0465	0.0023	-0.0535	-0.0337	-0.0035
2877.6	0.0	0.0915	0.0346	0.0042	-0.0376	-0.0360	-0.0070
2863.2	0.0	0.0910	0.0350	0.0034	-0.0379	-0.0358	-0.0072
3820.8	-8.0	0.0927	0.0201	0.0100	-0.0753	-0.0377	0.0016
3820.8	-8.0	0.0924	0.0194	0.0099	-0.0741	-0.0384	0.0010
3825.6	-8.0	0.0921	0.0184	0.0098	-0.0736	-0.0402	0.0010
3835.2	-6.0	0.0930	0.0254	0.0104	-0.0665	-0.0369	0.0032
3811.2	-4.0	0.0937	0.0293	0.0104	-0.0593	-0.0368	0.0021
3796.9	-4.0	0.0940	0.0292	0.0105	-0.0592	-0.0369	0.0022
3816.0	-4.0	0.0940	0.0297	0.0099	-0.0597	-0.0367	0.0025
3816.0	-2.0	0.0945	0.0329	0.0093	-0.0518	-0.0375	0.0015
1934.4	0.0	0.0883	0.0432	0.0016	-0.0480	-0.0351	-0.0039
2892.0	0.0	0.0912	0.0363	0.0035	-0.0389	-0.0366	-0.0070
3859.1	0.0	0.0958	0.0372	0.0150	-0.0427	-0.0384	-0.0066
3873.5	0.0	0.0957	0.0372	0.0158	-0.0416	-0.0389	-0.0069
3873.5	0.0	0.0957	0.0373	0.0148	-0.0426	-0.0385	-0.0060

Run# 107

Dynamic Pressure (N/m ²)	Angle of Attack (deg)	D/q (m ²)	L/q (m ²)	SF/q (m ²)	PM/q (m ³)	YM/q (m ³)	RM/q (m ³)
1896.0	0.0	0.0706	0.0277	0.0117	-0.0484	-0.0358	-0.0046
2877.6	0.0	0.0739	0.0203	0.0124	-0.0385	-0.0378	-0.0070
3811.2	-8.0	0.0769	0.0082	0.0126	-0.0740	-0.0382	-0.0013
3820.8	-2.0	0.0766	0.0189	0.0112	-0.0511	-0.0373	-0.0025
3868.7	0.0	0.0777	0.0215	0.0132	-0.0425	-0.0393	-0.0059
3835.2	2.0	0.0797	0.0244	0.0154	-0.0344	-0.0421	-0.0103
1920.0	0.0	0.0702	0.0246	0.0088	-0.0446	-0.0350	-0.0046
2877.6	0.0	0.0748	0.0212	0.0111	-0.0413	-0.0379	-0.0067
3825.6	0.0	0.0773	0.0209	0.0117	-0.0424	-0.0398	-0.0064

Run# 108

Dynamic Pressure (N/m ²)	Angle of Attack (deg)	D/q (m ²)	L/q (m ²)	SF/q (m ²)	PM/q (m ³)	YM/q (m ³)	RM/q (m ³)
1910.4	0.0	0.0750	0.0203	0.0065	-0.0435	-0.0354	-0.0056
2853.6	0.0	0.0795	0.0173	0.0095	-0.0393	-0.0384	-0.0069
3849.6	-8.0	0.0805	0.0018	0.0069	-0.0707	-0.0391	-0.0010
3796.9	0.0	0.0817	0.0185	0.0096	-0.0427	-0.0399	-0.0050
3849.6	-8.0	0.0805	0.0017	0.0060	-0.0706	-0.0411	0.0068
3840.0	-8.0	0.0802	0.0020	0.0073	-0.0703	-0.0390	-0.0001
3816.0	-2.0	0.0803	0.0139	0.0085	-0.0484	-0.0379	-0.0023
3811.2	-2.0	0.0804	0.0138	0.0088	-0.0493	-0.0388	-0.0021
3796.9	-2.0	0.0800	0.0135	0.0087	-0.0480	-0.0387	-0.0019
3796.9	0.0	0.0817	0.0183	0.0105	-0.0425	-0.0403	-0.0050
3792.1	0.0	0.0815	0.0179	0.0106	-0.0421	-0.0404	-0.0056
3796.9	0.0	0.0817	0.0191	0.0095	-0.0428	-0.0410	-0.0052
3825.6	2.0	0.0842	0.0247	0.0130	-0.0385	-0.0434	-0.0081

Run# 109

Dynamic Pressure (N/m ²)	Angle of Attack (deg)	D/q (m ²)	L/q (m ²)	SF/q (m ²)	PM/q (m ³)	YM/q (m ³)	RM/q (m ³)
1943.9	0.0	0.0744	0.0245	0.0041	-0.0451	-0.0354	-0.0047
2892.0	0.0	0.0780	0.0192	0.0020	-0.0370	-0.0368	-0.0082
3830.4	-2.0	0.0795	0.0164	0.0019	-0.0484	-0.0362	-0.0077
3830.4	0.0	0.0811	0.0216	0.0035	-0.0424	-0.0388	-0.0068

Run# 110

Dynamic Pressure (N/m ²)	Angle of Attack (deg)	D/q (m ²)	L/q (m ²)	SF/q (m ²)	PM/q (m ³)	YM/q (m ³)	RM/q (m ³)
1900.8	0.0	0.0732	0.0269	0.0103	-0.0431	-0.0356	-0.0074
2858.4	0.0	0.0764	0.0210	0.0109	-0.0351	-0.0375	-0.0076
3825.6	-8.0	0.0790	0.0102	0.0107	-0.0701	-0.0395	-0.0022
3820.8	-2.0	0.0782	0.0206	0.0082	-0.0484	-0.0375	-0.0018
3811.2	0.0	0.0792	0.0237	0.0130	-0.0413	-0.0388	-0.0063
3840.0	2.0	0.0816	0.0305	0.0142	-0.0384	-0.0424	-0.0087

Run# 111

Dynamic Pressure: (N/m ²)	Angle of Attack (deg)	D/q (m ²)	L/q (m ²)	SF/q (m ²)	PM/q (m ³)	YM/q (m ³)	RM/q (m ³)
1915.2	0.0	0.0708	0.0218	0.0111	-0.0435	-0.0343	-0.0063
2872.8	0.0	0.0745	0.0158	0.0129	-0.0365	-0.0369	-0.0077
3830.4	-8.0	0.0768	0.0049	0.0135	-0.0704	-0.0387	0.0019
3835.2	-2.0	0.0761	0.0139	0.0113	-0.0478	-0.0382	0.0003
3811.2	0.0	0.0770	0.0161	0.0132	-0.0403	-0.0396	-0.0034
3840.0	0.0	0.0773	0.0161	0.0125	-0.0396	-0.0410	-0.0032
3825.6	0.0	0.0773	0.0169	0.0126	-0.0403	-0.0399	-0.0024
3844.8	2.0	0.0791	0.0206	0.0103	-0.0355	-0.0428	-0.0064

Run# 115

Dynamic Pressure (N/m ²)	Angle of Attack (deg)	D/q (m ²)	L/q (m ²)	SF/q (m ²)	PM/q (m ³)	YM/q (m ³)	RM/q (m ³)
1905.6	0.0	0.0819	0.0390	0.0173	-0.0552	-0.0325	-0.0029
2868.0	0.0	0.0841	0.0411	0.0158	-0.0602	-0.0355	-0.0024
3835.2	-8.0	0.0843	0.0257	0.0129	-0.0856	-0.0357	0.0007
3811.2	-6.0	0.0846	0.0272	0.0120	-0.0752	-0.0357	0.0018
3835.2	-4.0	0.0850	0.0282	0.0123	-0.0659	-0.0357	-0.0002
3830.4	-2.0	0.0849	0.0322	0.0116	-0.0603	-0.0365	-0.0014
3816.0	0.0	0.0861	0.0413	0.0150	-0.0624	-0.0378	-0.0022
3811.2	2.0	0.0886	0.0470	0.0190	-0.0585	-0.0412	-0.0059
3796.9	0.0	0.0859	0.0418	0.0141	-0.0632	-0.0376	-0.0060

Run# 116

Dynamic Pressure (N/m ²)	Angle of Attack (deg)	D/q (m ²)	L/q (m ²)	SF/q (m ²)	PM/q (m ³)	YM/q (m ³)	RM/q (m ³)
1929.6	0.0	0.0846	0.0537	0.0127	-0.0611	-0.0349	-0.0033
2858.4	0.0	0.0865	0.0540	0.0174	-0.0650	-0.0371	-0.0015
3868.7	-8.0	0.0858	0.0299	0.0138	-0.0857	-0.0380	0.0050
3840.0	-6.0	0.0857	0.0324	0.0125	-0.0752	-0.0367	0.0063
3844.8	-4.0	0.0865	0.0339	0.0132	-0.0650	-0.0354	0.0037
3840.0	-2.0	0.0875	0.0393	0.0133	-0.0595	-0.0368	0.0024
3840.0	0.0	0.0899	0.0463	0.0190	-0.0538	-0.0388	-0.0001
3849.6	0.0	0.0896	0.0456	0.0188	-0.0535	-0.0388	-0.0005
3830.4	0.0	0.0897	0.0467	0.0179	-0.0549	-0.0387	0.0000
3849.6	2.0	0.0916	0.0513	0.0246	-0.0485	-0.0423	-0.0050

Run# 117

Dynamic Pressure (N/m ²)	Angle of Attack (deg)	D/q (m ²)	L/q (m ²)	SF/q (m ²)	PM/q (m ³)	YM/q (m ³)	RM/q (m ³)
1910.4	0.0	0.0810	0.0459	0.0258	-0.0562	-0.0332	-0.0050
2896.7	0.0	0.0838	0.0493	0.0244	-0.0639	-0.0365	-0.0025
3820.8	-8.0	0.0837	0.0268	0.0106	-0.0872	-0.0373	0.0013
3835.2	-6.0	0.0833	0.0268	0.0089	-0.0739	-0.0360	0.0011
3830.4	-4.0	0.0837	0.0304	0.0098	-0.0673	-0.0359	0.0003
3840.0	-2.0	0.0849	0.0381	0.0215	-0.0623	-0.0346	-0.0023
3811.2	0.0	0.0864	0.0446	0.0279	-0.0583	-0.0385	-0.0045
3825.6	2.0	0.0879	0.0520	0.0371	-0.0573	-0.0419	-0.0083

Run# 118

Dynamic Pressure (N/m ²)	Angle of Attack (deg)	D/q (m ²)	L/q (m ²)	SF/q (m ²)	PM/q (m ³)	YM/q (m ³)	RM/q (m ³)
1920.0	0.0	0.0781	0.0366	0.0334	-0.0581	-0.0334	-0.0052
2920.7	0.0	0.0815	0.0398	-0.0002	-0.0657	-0.0375	-0.0012
3830.4	-8.0	0.0833	0.0207	-0.0001	-0.0858	-0.0418	0.0012
3811.2	-6.0	0.0837	0.0202	-0.0021	-0.0721	-0.0399	0.0015
3830.4	-4.0	0.0837	0.0231	-0.0043	-0.0639	-0.0378	0.0010
3835.2	-2.0	0.0846	0.0253	-0.0036	-0.0560	-0.0385	-0.0012
3796.9	0.0	0.0863	0.0291	0.0026	-0.0500	-0.0423	-0.0044
3787.3	2.0	0.0875	0.0327	0.0100	-0.0433	-0.0413	-0.0097

Run# 119

Dynamic Pressure (N/m ²)	Angle of Attack (deg)	D/q (m ²)	L/q (m ²)	SF/q (m ²)	PM/q (m ³)	YM/q (m ³)	RM/q (m ³)
1886.5	0.0	0.0830	0.0406	0.0177	-0.0539	-0.0335	-0.0051
2853.6	0.0	0.0854	0.0405	0.0154	-0.0570	-0.0360	-0.0030
3782.5	-8.0	0.0849	0.0286	0.0138	-0.0864	-0.0355	0.0014
3830.4	-6.0	0.0854	0.0287	0.0137	-0.0743	-0.0347	0.0016
3844.8	-4.0	0.0861	0.0287	0.0135	-0.0622	-0.0352	-0.0001
3854.3	-2.0	0.0869	0.0319	0.0140	-0.0561	-0.0353	-0.0011
3820.8	0.0	0.0882	0.0342	0.0154	-0.0491	-0.0374	-0.0036
3835.2	2.0	0.0905	0.0370	0.0184	-0.0425	-0.0413	-0.0080

Run# 120

Dynamic Pressure (N/m ²)	Angle of Attack (deg)	D/q (m ²)	L/q (m ²)	SF/q (m ²)	PM/q (m ³)	YM/q (m ³)	RM/q (m ³)
1905.6	0.0	0.0815	0.0378	0.0170	-0.0522	-0.0340	-0.0044
2887.2	0.0	0.0835	0.0391	0.0171	-0.0568	-0.0374	-0.0029
3801.7	-8.0	0.0837	0.0254	0.0142	-0.0839	-0.0351	0.0039
3820.8	-8.0	0.0841	0.0267	0.0151	-0.0857	-0.0362	0.0042
3830.4	-8.0	0.0840	0.0265	0.0145	-0.0848	-0.0356	0.0041
3811.2	-6.0	0.0840	0.0280	0.0138	-0.0754	-0.0350	0.0057
3825.6	-4.0	0.0849	0.0283	0.0147	-0.0639	-0.0358	0.0037
3820.8	-2.0	0.0851	0.0322	0.0150	-0.0583	-0.0366	0.0030
3820.8	0.0	0.0853	0.0363	0.0171	-0.0539	-0.0391	0.0005
3830.4	2.0	0.0873	0.0387	0.0203	-0.0462	-0.0422	-0.0039

Run# 121

Dynamic Pressure (N/m ²)	Angle of Attack (deg)	D/q (m ²)	L/q (m ²)	SF/q (m ²)	PM/q (m ³)	YM/q (m ³)	RM/q (m ³)
1915.2	0.0	0.0811	0.0288	0.0135	-0.0399	-0.0350	-0.0065
2848.9	0.0	0.0846	0.0289	0.0159	-0.0427	-0.0368	-0.0059
3820.8	-8.0	0.0855	0.0199	0.0125	-0.0756	-0.0377	0.0021
3782.5	-6.0	0.0848	0.0216	0.0126	-0.0658	-0.0374	0.0028
3816.0	-4.0	0.0851	0.0244	0.0122	-0.0585	-0.0374	0.0029
3792.1	-2.0	0.0855	0.0257	0.0135	-0.0503	-0.0376	0.0010
3820.8	0.0	0.0866	0.0286	0.0161	-0.0430	-0.0396	-0.0026
3811.2	2.0	0.0888	0.0337	0.0176	-0.0398	-0.0440	-0.0057

Run# 122

Dynamic Pressure (N/m ²)	Angle of Attack (deg)	D/q (m ²)	L/q (m ²)	SF/q (m ²)	PM/q (m ³)	YM/q (m ³)	RM/q (m ³)
1891.3	0.0	0.0804	0.0280	0.0160	-0.0401	-0.0366	-0.0072
2877.6	0.0	0.0836	0.0272	0.0164	-0.0404	-0.0381	-0.0058
3787.3	-8.0	0.0848	0.0184	0.0137	-0.0742	-0.0380	0.0025
3816.0	-6.0	0.0846	0.0202	0.0132	-0.0652	-0.0374	0.0033
3825.6	-4.0	0.0838	0.0237	0.0138	-0.0593	-0.0369	0.0034
3816.0	-2.0	0.0843	0.0273	0.0147	-0.0529	-0.0382	0.0015
3816.0	0.0	0.0849	0.0321	0.0167	-0.0494	-0.0402	0.0003
3820.8	2.0	0.0868	0.0366	0.0199	-0.0461	-0.0431	-0.0042

Run# 123

Dynamic Pressure (N/m ²)	Angle of Attack (deg)	D/q (m ²)	L/q (m ²)	SF/q (m ²)	PM/q (m ³)	YM/q (m ³)	RM/q (m ³)
1910.4	0.0	0.0806	0.0140	0.0070	-0.0383	-0.0353	-0.0097
1915.2	0.0	0.0806	0.0137	0.0086	-0.0393	-0.0350	-0.0100
1915.2	0.0	0.0806	0.0151	0.0093	-0.0402	-0.0345	-0.0093
2896.7	0.0	0.0845	0.0207	0.0081	-0.0499	-0.0383	-0.0059
3835.2	-8.0	0.0865	0.0099	0.0089	-0.0747	-0.0400	0.0032
3820.8	-6.0	0.0851	0.0114	0.0079	-0.0667	-0.0380	0.0040
3806.5	-4.0	0.0847	0.0132	0.0074	-0.0596	-0.0368	0.0028
3816.0	-2.0	0.0844	0.0156	0.0065	-0.0537	-0.0373	0.0015
3806.5	0.0	0.0850	0.0176	0.0082	-0.0471	-0.0398	-0.0023
3792.1	0.0	0.0847	0.0187	0.0088	-0.0471	-0.0397	-0.0017
3816.0	0.0	0.0845	0.0178	0.0083	-0.0471	-0.0392	-0.0022
3796.8	2.0	0.0865	0.0221	0.0107	-0.0442	-0.0419	-0.0059
3811.2	0.0	0.0844	0.0186	0.0081	-0.0479	-0.0399	-0.0038
2882.4	0.0	0.0816	0.0174	0.0079	-0.0456	-0.0385	-0.0046
1929.6	0.0	0.0779	0.0166	0.0088	-0.0432	-0.0356	-0.0039
1939.6	0.0	0.0779	0.0161	0.0085	-0.0420	-0.0362	-0.0042
1934.4	0.0	0.0780	0.0161	0.0083	-0.0421	-0.0359	-0.0045
2883.2	0.0	0.0819	0.0165	0.0065	-0.0445	-0.0377	-0.0050
3820.8	0.0	0.0849	0.0183	0.0088	-0.0474	-0.0402	-0.0049

Run# 124

Dynamic Pressure (N/m ²)	Angle of Attack (deg)	D/q (m ²)	L/q (m ²)	SF/q (m ²)	PM/q (m ³)	YM/q (m ³)	RM/q (m ³)
1934.4	0.0	0.0743	0.0166	0.0115	-0.0440	-0.0360	-0.0066
2887.2	0.0	0.0781	0.0157	0.0128	-0.0444	-0.0379	-0.0059
3811.2	-8.0	0.0813	-0.0004	0.0103	-0.0712	-0.0406	0.0006
3796.9	-6.0	0.0804	0.0018	0.0123	-0.0605	-0.0380	0.0008
3777.7	-4.0	0.0796	0.0047	0.0127	-0.0533	-0.0371	-0.0001
3835.2	-2.0	0.0794	0.0077	0.0113	-0.0455	-0.0383	-0.0028
3816.0	0.0	0.0801	0.0119	0.0124	-0.0400	-0.0410	-0.0051
3811.2	2.0	0.0818	0.0201	0.0162	-0.0400	-0.0426	-0.0075

Run# 125

Dynamic Pressure (N/m ²)	Angle of Attack (deg)	D/q (m ²)	L/q (m ²)	SF/q (m ²)	PM/q (m ³)	YM/q (m ³)	RM/q (m ³)
1924.8	0.0	0.0740	0.0162	0.0088	-0.0394	-0.0357	-0.0078
2896.7	0.0	0.0771	0.0158	0.0107	-0.0402	-0.0374	-0.0075
3840.0	-8.0	0.0811	0.0021	0.0123	-0.0697	-0.0399	0.0015
3820.8	-6.0	0.0797	0.0064	0.0123	-0.0633	-0.0377	0.0026
3796.9	-4.0	0.0787	0.0091	0.0115	-0.0563	-0.0373	0.0013
3825.6	-2.0	0.0787	0.0130	0.0105	-0.0501	-0.0379	-0.0004
3811.2	0.0	0.0794	0.0170	0.0124	-0.0429	-0.0393	-0.0041
3806.5	2.0	0.0811	0.0229	0.0137	-0.0395	-0.0426	-0.0088

Run# 126

Dynamic Pressure (N/m ²)	Angle of Attack (deg)	D/q (m ²)	L/q (m ²)	SF/q (m ²)	PM/q (m ³)	YM/q (m ³)	RM/q (m ³)
1915.2	0.0	0.0829	0.0172	0.0098	-0.0396	-0.0355	-0.0089
1924.8	0.0	0.0825	0.0164	0.0122	-0.0379	-0.0356	-0.0094
2877.6	0.0	0.0853	0.0147	0.0111	-0.0372	-0.0382	-0.0096
3859.1	-8.0	0.0862	0.0069	0.0091	-0.0662	-0.0385	-0.0022
3859.1	-6.0	0.0875	0.0095	0.0085	-0.0602	-0.0380	0.0000
3868.7	-4.0	0.0870	0.0121	0.0084	-0.0538	-0.0363	-0.0007
3854.3	-2.0	0.0868	0.0144	0.0094	-0.0473	-0.0378	-0.0030
3844.8	0.0	0.0873	0.0164	0.0116	-0.0404	-0.0398	-0.0055
3820.8	2.0	0.0889	0.0207	0.0172	-0.0360	-0.0435	-0.0087

Run# 127

Dynamic Pressure (N/m ²)	Angle of Attack (deg)	D/q (m ²)	L/q (m ²)	SF/q (m ²)	PM/q (m ³)	YM/q (m ³)	RM/q (m ³)
1910.4	0.0	0.0759	0.0109	0.0128	-0.0369	-0.0350	-0.0118
1905.6	0.0	0.0763	0.0119	0.0112	-0.0388	-0.0356	-0.0108
1905.6	0.0	0.0759	0.0119	0.0128	-0.0386	-0.0347	-0.0103
2863.2	0.0	0.0791	0.0098	0.0141	-0.0353	-0.0383	-0.0106
3816.0	-8.0	0.0832	-0.019	0.0135	-0.0673	-0.0403	-0.0010
3816.0	-6.0	0.0818	0.0027	0.0136	-0.0620	-0.0380	0.0004
3816.0	-4.0	0.0811	0.0057	0.0127	-0.0555	-0.0366	0.0003
3806.5	-2.0	0.0803	0.0085	0.0123	-0.0479	-0.0368	-0.0026
3811.2	0.0	0.0810	0.0114	0.0153	-0.0397	-0.0391	-0.0055
3825.6	2.0	0.0829	0.0170	0.0181	-0.0361	-0.0421	-0.0091

Run# 128

Dynamic Pressure (N/m ²)	Angle of Attack (deg)	D/q (m ²)	L/q (m ²)	SF/q (m ²)	PM/q (m ³)	YM/q (m ³)	RM/q (m ³)
1915.2	0.0	0.0748	0.0170	0.0125	-0.0408	-0.0352	-0.0081
2858.4	0.0	0.0784	0.0162	0.0129	-0.0402	-0.0373	-0.0080
3863.9	-8.0	0.0825	0.0025	0.0144	-0.0712	-0.0393	0.0013
3878.3	-6.0	0.0813	0.0079	0.0147	-0.0667	-0.0380	0.0039
3863.9	-4.0	0.0800	0.0109	0.0139	-0.0587	-0.0373	0.0024
3854.3	-2.0	0.0797	0.0141	0.0135	-0.0515	-0.0378	0.0001
3830.4	0.0	0.0806	0.0177	0.0157	-0.0437	-0.0402	-0.0034
3835.2	2.0	0.0820	0.0222	0.0186	-0.0380	-0.0431	-0.0071
3859.1	0.0	0.0801	0.0182	0.0154	-0.0440	-0.0398	-0.0047
2906.3	0.0	0.0767	0.0150	0.0147	-0.0382	-0.0377	-0.0061
1948.7	0.0	0.0724	0.0185	0.0128	-0.0422	-0.0347	-0.0036

Run# 129

Dynamic Pressure (N/m ²)	Angle of Attack (deg)	D/q (m ²)	L/q (m ²)	SF/q (m ²)	PM/q (m ³)	YM/q (m ³)	RM/q (m ³)
1939.1	0.0	0.0824	0.0156	0.0108	-0.0426	-0.0349	-0.0072
2887.2	0.0	0.0858	0.0143	0.0126	-0.0419	-0.0384	-0.0072
3859.1	-8.0	0.0892	0.0085	0.0152	-0.0705	-0.0395	0.0009
3835.2	-6.0	0.0873	0.0116	0.0145	-0.0658	-0.0375	0.0025
3840.0	-2.0	0.0872	0.0148	0.0131	-0.0523	-0.0370	-0.0012
3835.2	0.0	0.0879	0.0157	0.0144	-0.0435	-0.0397	-0.0045
3806.5	2.0	0.0896	0.0190	0.0166	-0.0390	-0.0424	-0.0083

Run# 130

Dynamic Pressure (N/m ²)	Angle of Attack (deg)	D/q (m ²)	L/q (m ²)	SF/q (m ²)	PM/q (m ³)	YM/q (m ³)	RM/q (m ³)
1910.4	0.0	0.0750	0.0158	0.0123	-0.0432	-0.0359	-0.0082
2853.6	0.0	0.0783	0.0117	0.0134	-0.0379	-0.0386	-0.0085
3825.8	-8.0	0.0826	0.0009	0.0128	-0.0719	-0.0390	0.0004
3820.8	-6.0	0.0811	0.0064	0.0127	-0.0679	-0.0385	0.0025
3830.4	-4.0	0.0799	0.0103	0.0134	-0.0622	-0.0372	0.0007
3792.1	-2.0	0.0795	0.0127	0.0131	-0.0534	-0.0378	-0.0011
3811.2	0.0	0.0805	0.0145	0.0131	-0.0437	-0.0400	-0.0045
3825.6	2.0	0.0820	0.0181	0.0160	-0.0374	-0.0441	-0.0083

Run# 131

Dynamic Pressure (N/m ²)	Angle of Attack (deg)	D/q (m ²)	L/q (m ²)	SF/q (m ²)	PM/q (m ³)	YM/q (m ³)	RM/q (m ³)
1891.3	0.0	0.0734	0.0186	0.0113	-0.0452	-0.0350	-0.0072
2877.6	0.0	0.0751	0.0150	0.0107	-0.0398	-0.0369	-0.0071
3816.0	-8.0	0.0804	0.0052	0.0133	-0.0770	-0.0391	0.0027
3825.6	-6.0	0.0794	0.0090	0.0149	-0.0695	-0.0382	0.0042
3825.6	-4.0	0.0787	0.0115	0.0133	-0.0611	-0.0369	0.0030
3830.4	-2.0	0.0783	0.0145	0.0116	-0.0535	-0.0382	0.0012
3806.5	0.0	0.0792	0.0164	0.0138	-0.0435	-0.0415	-0.0026
3816.0	2.0	0.0808	0.0214	0.0154	-0.0385	-0.0431	-0.0057

Run# 132

Dynamic Pressure (N/m ²)	Angle of Attack (deg)	D/q (m ²)	L/q (m ²)	SF/q (m ²)	PM/q (m ³)	YM/q (m ³)	RM/q (m ³)
1891.3	0.0	0.0807	0.0188	0.0113	-0.0454	-0.0351	-0.0078
2872.8	0.0	0.0830	0.0166	0.0108	-0.0427	-0.0377	-0.0065
3854.3	-8.0	0.0860	0.0113	0.0141	-0.0751	-0.0382	0.0029
3830.4	-6.0	0.0856	0.0142	0.0137	-0.0696	-0.0379	0.0052
3835.2	-4.0	0.0851	0.0147	0.0123	-0.0612	-0.0377	0.0035
3840.0	-2.0	0.0849	0.0154	0.0101	-0.0525	-0.0376	0.0007
3830.4	0.0	0.0862	0.0172	0.0116	-0.0443	-0.0406	-0.0021
3806.5	2.0	0.0875	0.0197	0.0126	-0.0386	-0.0426	-0.0056

Run# 133

Dynamic Pressure (N/m ²)	Angle of Attack (deg)	D/q (m ²)	L/q (m ²)	SF/q (m ²)	PM/q (m ³)	YM/q (m ³)	RM/q (m ³)
1924.8	0.0	0.0735	0.0201	0.0132	-0.0475	-0.0346	-0.0078
2872.8	0.0	0.0766	0.0136	0.0125	-0.0392	-0.0377	-0.0082
3844.8	-8.0	0.0810	0.0054	0.0113	-0.0773	-0.0393	0.0024
3844.8	-6.0	0.0789	0.0081	0.0123	-0.0686	-0.0369	0.0019
3844.8	-4.0	0.0791	0.0103	0.0120	-0.0601	-0.0373	0.0015
3844.8	-2.0	0.0789	0.0131	0.0132	-0.0523	-0.0373	-0.0015
3816.0	0.0	0.0786	0.0150	0.0157	-0.0432	-0.0395	-0.0050
3811.2	2.0	0.0815	0.0204	0.0172	-0.0387	-0.0428	-0.0080

Run# 134

Dynamic Pressure (N/m ²)	Angle of Attack (deg)	D/q (m ²)	L/q (m ²)	SF/q (m ²)	PM/q (m ³)	YM/q (m ³)	RM/q (m ³)
3878.3	-8.0	0.0795	0.0095	0.0145	-0.0778	-0.0386	0.0037
3854.3	-6.0	0.0781	0.0117	0.0153	-0.0689	-0.0362	0.0035
3854.3	-4.0	0.0778	0.0145	0.0137	-0.0612	-0.0364	0.0026
3849.6	-2.0	0.0777	0.0169	0.0129	-0.0527	-0.0365	-0.0002
3840.0	0.0	0.0781	0.0188	0.0131	-0.0434	-0.0378	-0.0043
3816.0	2.0	0.0797	0.0235	0.0161	-0.0372	-0.0420	-0.0079

Run# 135

Dynamic Pressure (N/m ²)	Angle of Attack (deg)	D/q (m ²)	L/q (m ²)	SF/q (m ²)	PM/q (m ³)	YM/q (m ³)	RM/q (m ³)
1905.6	0.0	0.0761	0.0128	0.0119	-0.0430	-0.0371	-0.0087
2863.2	0.0	0.0794	0.0138	0.0096	-0.0451	-0.0384	-0.0074
3796.9	-8.0	0.0821	0.0056	0.0143	-0.0748	-0.0388	0.0026
3816.0	-6.0	0.0819	0.0075	0.0143	-0.0670	-0.0382	0.0044
3830.4	-4.0	0.0813	0.0089	0.0135	-0.0606	-0.0378	0.0030
3820.8	-2.0	0.0810	0.0112	0.0113	-0.0540	-0.0398	-0.0002
3806.5	0.0	0.0825	0.0134	0.0122	-0.0459	-0.0415	-0.0039
3835.2	2.0	0.0839	0.0157	0.0144	-0.0393	-0.0433	-0.0069

Run# 136

Dynamic Pressure (N/m ²)	Angle of Attack (deg)	D/q (m ²)	L/q (m ²)	SF/q (m ²)	PM/q (m ³)	YM/q (m ³)	RM/q (m ³)
1943.9	0.0	0.0757	0.0211	0.0135	-0.0433	-0.0360	-0.0070
2858.4	0.0	0.0791	0.0218	0.0135	-0.0448	-0.0375	-0.0063
3849.6	-8.0	0.0840	0.0038	0.0120	-0.0770	-0.0388	0.0040
3844.8	-6.0	0.0824	0.0087	0.0124	-0.0695	-0.0382	0.0054
3835.2	-4.0	0.0815	0.0124	0.0110	-0.0614	-0.0385	0.0050
3820.8	-2.0	0.0806	0.0172	0.0121	-0.0538	-0.0380	0.0021
3801.7	0.0	0.0817	0.0212	0.0146	-0.0454	-0.0408	-0.0012
3801.7	2.0	0.0846	0.0275	0.0205	-0.0397	-0.0436	-0.0056

Run# 137

Dynamic Pressure (N/m ²)	Angle of Attack (deg)	D/q (m ²)	L/q (m ²)	SF/q (m ²)	PM/q (m ³)	YM/q (m ³)	RM/q (m ³)
1915.2	0.0	0.0718	0.0265	0.0121	-0.0439	-0.0363	-0.0085
2848.9	0.0	0.0745	0.0265	0.0176	-0.0444	-0.0383	-0.0075
3835.2	-8.0	0.0786	0.0097	0.0157	-0.0780	-0.0390	0.0014
3849.6	-8.0	0.0777	0.0162	0.0138	-0.0717	-0.0380	0.0027
3840.0	-4.0	0.0773	0.0182	0.0142	-0.0614	-0.0374	0.0010
3840.0	-2.0	0.0770	0.0232	0.0115	-0.0548	-0.0375	-0.0009
3816.0	0.0	0.0777	0.0262	0.0127	-0.0459	-0.0387	-0.0044
3820.8	2.0	0.0784	0.0302	0.0157	-0.0389	-0.0424	-0.0093

Run# 138

Dynamic Pressure (N/m ²)	Angle of Attack (deg)	D/q (m ²)	L/q (m ²)	SF/q (m ²)	PM/q (m ³)	YM/q (m ³)	RM/q (m ³)
1800.8	0.0	0.0704	0.0199	0.0143	-0.0433	-0.0350	-0.0076
2887.2	0.0	0.0733	0.0190	0.0157	-0.0427	-0.0379	-0.0078
3840.0	-8.0	0.0775	0.0027	0.0147	-0.0778	-0.0383	0.0029
3830.4	-6.0	0.0766	0.0069	0.0141	-0.0703	-0.0375	0.0032
3835.2	-4.0	0.0755	0.0097	0.0143	-0.0603	-0.0367	0.0013
3816.0	-2.0	0.0757	0.0142	0.0119	-0.0533	-0.0371	-0.0005
3806.5	0.0	0.0767	0.0182	0.0137	-0.0439	-0.0395	-0.0043
3849.6	2.0	0.0786	0.0253	0.0185	-0.0385	-0.0420	-0.0090

Run# 139

Dynamic Pressure (N/m ²)	Angle of Attack (deg)	D/q (m ²)	L/q (m ²)	SF/q (m ²)	PM/q (m ³)	YM/q (m ³)	RM/q (m ³)
1910.4	0.0	0.0724	0.0177	0.0163	-0.0424	-0.0349	-0.0093
2887.2	0.0	0.0740	0.0162	0.0154	-0.0420	-0.0370	-0.0079
3820.8	-8.0	0.0792	-0.013	0.0146	-0.0770	-0.0388	0.0014
3816.0	-6.0	0.0780	0.0044	0.0154	-0.0689	-0.0372	0.0025
3820.8	-4.0	0.0772	0.0073	0.0153	-0.0591	-0.0361	0.0004
3816.0	-2.0	0.0768	0.0122	0.0133	-0.0522	-0.0379	-0.0010
3830.4	0.0	0.0773	0.0154	0.0167	-0.0424	-0.0397	-0.0053
3825.6	2.0	0.0791	0.0222	0.0193	-0.0369	-0.0411	-0.0095

Run# 140

Dynamic Pressure (N/m ²)	Angle of Attack (deg)	D/q (m ²)	L/q (m ²)	SF/q (m ²)	PM/q (m ³)	YM/q (m ³)	RM/q (m ³)
1943.8	0.0	0.0755	0.0222	0.0158	-0.0442	-0.0353	-0.0066
2877.6	0.0	0.0776	0.0187	0.0136	-0.0406	-0.0367	-0.0069
3854.3	-8.0	0.0836	0.0031	0.0134	-0.0753	-0.0376	0.0018
3844.8	-6.0	0.0821	0.0087	0.0127	-0.0697	-0.0376	0.0029
3844.8	-4.0	0.0811	0.0115	0.0123	-0.0592	-0.0383	0.0019
3835.2	-2.0	0.0804	0.0158	0.0131	-0.0513	-0.0371	-0.0013
3820.8	0.0	0.0810	0.0201	0.0151	-0.0433	-0.0389	-0.0054
3830.4	2.0	0.0829	0.0262	0.0190	-0.0378	-0.0415	-0.0093

Run# 141

Dynamic Pressure (N/m ²)	Angle of Attack (deg)	D/q (m ²)	L/q (m ²)	SF/q (m ²)	PM/q (m ³)	YM/q (m ³)	RM/q (m ³)
1963.1	0.0	0.0705	0.0267	0.0136	-0.0467	-0.0351	-0.0056
2872.8	0.0	0.0728	0.0234	0.0156	-0.0424	-0.0361	-0.0070
3863.9	-8.0	0.0767	0.0097	0.0134	-0.0765	-0.0365	0.0007
3849.6	-4.0	0.0759	0.0144	0.0146	-0.0700	-0.0365	0.0021
3835.2	-4.0	0.0753	0.0162	0.0125	-0.0605	-0.0365	0.0008
3859.1	-2.0	0.0754	0.0198	0.0124	-0.0532	-0.0366	-0.0011
3844.8	0.0	0.0754	0.0226	0.0153	-0.0441	-0.0378	-0.0058
3816.0	2.0	0.0773	0.0274	0.0182	-0.0401	-0.0423	-0.0083

Run# 142

Dynamic Pressure (N/m ²)	Angle of Attack (deg)	D/q (m ²)	L/q (m ²)	SF/q (m ²)	PM/q (m ³)	YM/q (m ³)	RM/q (m ³)
1953.5	0.0	0.0715	0.0280	0.0134	-0.0458	-0.0358	-0.0078
2868.0	0.0	0.0732	0.0240	0.0115	-0.0403	-0.0369	-0.0079
3868.7	-8.0	0.0777	0.0108	0.0138	-0.0773	-0.0390	0.0020
3887.9	-6.0	0.0768	0.0152	0.0142	-0.0702	-0.0382	0.0033
3873.5	-4.0	0.0763	0.0181	0.0130	-0.0601	-0.0364	0.0013
3863.9	-2.0	0.0759	0.0218	0.0114	-0.0533	-0.0368	-0.0007
3854.3	0.0	0.0767	0.0250	0.0111	-0.0450	-0.0389	-0.0035
3835.2	2.0	0.0779	0.0299	0.0133	-0.0393	-0.0407	-0.0082

Run# 143

Dynamic Pressure (N/m ²)	Angle of Attack (deg)	D/q (m ²)	L/q (m ²)	SF/q (m ²)	PM/q (m ³)	YM/q (m ³)	RM/q (m ³)
1920.0	0.0	0.0711	0.0181	0.0134	-0.0414	-0.0359	-0.0085
2882.4	0.0	0.0736	0.0188	0.0150	-0.0441	-0.0378	-0.0076
3816.0	-8.0	0.0775	0.0008	0.0142	-0.0860	-0.0375	-0.0018
3840.0	-8.0	0.0777	0.0013	0.0145	-0.0763	-0.0387	0.0004
3801.7	-6.0	0.0766	0.0050	0.0156	-0.0876	-0.0370	0.0013
3820.8	-4.0	0.0763	0.0084	0.0148	-0.0587	-0.0368	0.0003
3820.8	-2.0	0.0761	0.0134	0.0141	-0.0526	-0.0388	-0.0017
3835.2	0.0	0.0768	0.0182	0.0159	-0.0446	-0.0395	-0.0050
3820.8	2.0	0.0766	0.0242	0.0178	-0.0387	-0.0422	-0.0092

Run# 144

Dynamic Pressure (N/m ²)	Angle of Attack (deg)	D/q (m ²)	L/q (m ²)	SF/q (m ²)	PM/q (m ³)	YM/q (m ³)	RM/q (m ³)
1905.6	0.0	0.0731	0.0163	0.0135	-0.0422	-0.0344	-0.0061
2868.0	0.0	0.0751	0.0175	0.0150	-0.0437	-0.0376	-0.0080
3816.0	-8.0	0.0793	-0.0010	0.0132	-0.0768	-0.0394	0.0029
3811.2	-6.0	0.0784	0.0023	0.0155	-0.0660	-0.0375	0.0037
3830.4	-4.0	0.0777	0.0065	0.0145	-0.0585	-0.0379	0.0029
3816.0	-2.0	0.0772	0.0114	0.0133	-0.0516	-0.0378	0.0008
3816.0	0.0	0.0779	0.0161	0.0157	-0.0436	-0.0398	-0.0040
3825.6	2.0	0.0798	0.0227	0.0173	-0.0388	-0.0427	-0.0062

Run# 145

Dynamic Pressure (N/m ²)	Angle of Attack (deg)	D/q (m ²)	L/q (m ²)	SF/q (m ²)	PM/q (m ³)	YM/q (m ³)	RM/q (m ³)
1910.4	0.0	0.0787	0.0200	0.0135	-0.0441	-0.0358	-0.0098
2872.8	0.0	0.0811	0.0206	0.0119	-0.0461	-0.0378	-0.0066
3835.2	-8.0	0.0844	0.0132	0.0123	-0.0762	-0.0382	-0.0007
3830.4	-6.0	0.0838	0.0144	0.0124	-0.0672	-0.0363	0.0000
3840.0	-4.0	0.0835	0.0154	0.0116	-0.0586	-0.0365	-0.0004
3825.6	-2.0	0.0836	0.0177	0.0119	-0.0526	-0.0369	-0.0022
3820.8	0.0	0.0842	0.0198	0.0123	-0.0460	-0.0401	-0.0048
3825.6	2.0	0.0851	0.0224	0.0151	-0.0400	-0.0426	-0.0091

Run# 146

Dynamic Pressure (N/m ²)	Angle of Attack (deg)	D/q (m ²)	L/q (m ²)	SF/q (m ²)	PM/q (m ³)	YM/q (m ³)	RM/q (m ³)
1891.3	0.0	0.0774	0.0113	0.0092	-0.0407	-0.0363	-0.0095
2887.2	0.0	0.0797	0.0142	0.0119	-0.0458	-0.0385	-0.0090
3825.6	-8.0	0.0822	0.0058	0.0151	-0.0755	-0.0388	0.0025
3820.8	-6.0	0.0816	0.0068	0.0146	-0.0671	-0.0378	0.0040
3840.0	-4.0	0.0817	0.0078	0.0146	-0.0591	-0.0385	0.0032
3820.8	-2.0	0.0810	0.0101	0.0153	-0.0522	-0.0380	0.0002
3801.7	0.0	0.0825	0.0131	0.0142	-0.0454	-0.0413	-0.0048
3801.7	2.0	0.0844	0.0168	0.0145	-0.0409	-0.0443	-0.0065

Run# 147

Dynamic Pressure (N/m ²)	Angle of Attack (deg)	D/q (m ²)	L/q (m ²)	SF/q (m ²)	PM/q (m ³)	YM/q (m ³)	RM/q (m ³)
1920.0	0.0	0.0730	0.0336	0.0116	-0.0438	-0.0356	-0.0062
2858.4	0.0	0.0752	0.0333	0.0126	-0.0467	-0.0378	-0.0054
3830.4	-8.0	0.0787	0.0043	0.0147	-0.0791	-0.0398	0.0031
3811.2	-6.0	0.0770	0.0113	0.0155	-0.0687	-0.0372	0.0040
3811.2	-4.0	0.0766	0.0162	0.0158	-0.0587	-0.0369	0.0021
3816.0	-2.0	0.0762	0.0239	0.0140	-0.0526	-0.0376	0.0010
3811.2	0.0	0.0780	0.0315	0.0142	-0.0447	-0.0401	-0.0023
3806.5	2.0	0.0795	0.0401	0.0157	-0.0384	-0.0433	-0.0064

Run# 148

Dynamic Pressure (N/m ²)	Angle of Attack (deg)	D/q (m ²)	L/q (m ²)	SF/q (m ²)	PM/q (m ³)	YM/q (m ³)	RM/q (m ³)
1900.8	0.0	0.0721	0.0311	0.0145	-0.0445	-0.0359	-0.0076
2863.2	0.0	0.0739	0.0312	0.0124	-0.0472	-0.0367	-0.0068
3811.2	-8.0	0.0778	0.0053	0.0155	-0.0776	-0.0385	0.0027
3825.6	-6.0	0.0767	0.0113	0.0144	-0.0687	-0.0385	0.0044
3825.6	-4.0	0.0762	0.0163	0.0136	-0.0600	-0.0377	0.0033
3806.5	-2.0	0.0761	0.0223	0.0137	-0.0530	-0.0382	0.0012
3816.0	0.0	0.0769	0.0287	0.0139	-0.0456	-0.0402	-0.0020
3820.8	2.0	0.0788	0.0341	0.0148	-0.0394	-0.0426	-0.0059

Run# 149

Dynamic Pressure (N/m ²)	Angle of Attack (deg)	D/q (m ²)	L/q (m ²)	SF/q (m ²)	PM/q (m ³)	YM/q (m ³)	RM/q (m ³)
1915.2	0.0	0.0729	0.0151	0.0177	-0.0431	-0.0369	-0.0094
2858.4	0.0	0.0745	0.0167	0.0185	-0.0470	-0.0388	-0.0077
3820.8	-8.0	0.0785	0.0085	0.0164	-0.0771	-0.0396	0.0017
3820.8	-6.0	0.0774	0.0100	0.0178	-0.0685	-0.0383	0.0031
3825.6	-4.0	0.0772	0.0107	0.0167	-0.0595	-0.0385	0.0024
3816.0	-2.0	0.0768	0.0128	0.0173	-0.0528	-0.0379	0.0001
3801.7	0.0	0.0773	0.0151	0.0179	-0.0464	-0.0408	-0.0032
3811.2	2.0	0.0784	0.0181	0.0210	-0.0398	-0.0438	-0.0071

Run# 150

Dynamic Pressure (N/m ²)	Angle of Attack (deg)	D/q (m ²)	L/q (m ²)	SF/q (m ²)	PM/q (m ³)	YM/q (m ³)	RM/q (m ³)
1896.0	0.0	0.0730	0.0242	0.0155	-0.0428	-0.0351	-0.0092
2863.2	0.0	0.0760	0.0255	0.0186	-0.0466	-0.0379	-0.0073
3816.0	-8.0	0.0786	0.0106	0.0169	-0.0763	-0.0389	0.0029
3796.9	-6.0	0.0776	0.0135	0.0168	-0.0687	-0.0378	0.0046
3825.6	-4.0	0.0776	0.0153	0.0152	-0.0589	-0.0383	0.0031
3816.0	-2.0	0.0774	0.0192	0.0157	-0.0524	-0.0377	0.0005
3820.8	0.0	0.0787	0.0234	0.0191	-0.0462	-0.0406	-0.0022
3806.5	2.0	0.0804	0.0265	0.0216	-0.0396	-0.0438	-0.0071

Run# 151

Dynamic Pressure (N/m ²)	Angle of Attack (deg)	D/q (m ²)	L/q (m ²)	SF/q (m ²)	PM/q (m ³)	YM/q (m ³)	RM/q (m ³)
1929.6	0.0	0.0726	0.0124	0.0099	-0.0422	-0.0360	-0.0094
2868.0	0.0	0.0741	0.0127	0.0095	-0.0429	-0.0363	-0.0089
3811.2	-8.0	0.0789	0.0079	0.0112	-0.0757	-0.0381	0.0004
3830.4	-6.0	0.0780	0.0088	0.0106	-0.0679	-0.0377	0.0021
3835.2	-4.0	0.0774	0.0089	0.0095	-0.0592	-0.0358	0.0007
3835.2	-2.0	0.0772	0.0108	0.0086	-0.0520	-0.0366	-0.0016
3830.4	0.0	0.0779	0.0128	0.0105	-0.0454	-0.0391	-0.0045
3811.2	2.0	0.0788	0.0142	0.0139	-0.0386	-0.0421	-0.0086

Run# 152

Dynamic Pressure (N/m ²)	Angle of Attack (deg)	D/q (m ²)	L/q (m ²)	SF/q (m ²)	PM/q (m ³)	YM/q (m ³)	RM/q (m ³)
1900.8	0.0	0.0798	0.0143	0.0054	-0.0315	-0.0353	-0.0141
2872.8	0.0	0.0816	0.0161	0.0091	-0.0361	-0.0382	-0.0121
3811.2	-8.0	0.0834	0.0099	0.0069	-0.0699	-0.0396	-0.0011
3825.6	-6.0	0.0831	0.0115	0.0056	-0.0626	-0.0381	0.0006
3806.5	-4.0	0.0834	0.0123	0.0054	-0.0532	-0.0375	-0.0007
3811.2	-2.0	0.0833	0.0142	0.0050	-0.0459	-0.0379	-0.0028
3806.5	0.0	0.0836	0.0175	0.0083	-0.0399	-0.0402	-0.0047
3816.0	2.0	0.0853	0.0197	0.0117	-0.0326	-0.0439	-0.0093

Run# 153

Dynamic Pressure (N/m ²)	Angle of Attack (deg)	D/q (m ²)	L/q (m ²)	SF/q (m ²)	PM/q (m ³)	YM/q (m ³)	RM/q (m ³)
1915.2	0.0	0.0783	0.0132	0.0005	-0.0339	-0.0346	-0.0122
2872.8	0.0	0.0808	0.0172	0.0017	-0.0411	-0.0370	-0.0101
3825.6	-8.0	0.0821	0.0095	0.0027	-0.0737	-0.0418	0.0003
3816.0	-6.0	0.0818	0.0124	0.0029	-0.0672	-0.0393	0.0021
3806.5	-4.0	0.0829	0.0132	0.0042	-0.0580	-0.0373	0.0017
3830.4	-2.0	0.0833	0.0160	0.0012	-0.0507	-0.0378	0.0006
3825.6	0.0	0.0842	0.0176	0.0015	-0.0437	-0.0400	-0.0031
3830.4	2.0	0.0854	0.0192	0.0077	-0.0356	-0.0426	-0.0080

Run# 154

Dynamic Pressure (N/m ²)	Angle of Attack (deg)	D/q (m ²)	L/q (m ²)	SF/q (m ²)	PM/q (m ³)	YM/q (m ³)	RM/q (m ³)
1910.4	0.0	0.0712	0.0063	0.0077	-0.0343	-0.0340	-0.0106
1934.4	0.0	0.0713	0.0064	0.0069	-0.0349	-0.0340	-0.0113
2896.7	0.0	0.0746	0.0097	0.0055	-0.0424	-0.0373	-0.0086
3825.6	-8.0	0.0809	0.0055	0.0058	-0.0719	-0.0381	-0.0034
3840.0	-6.0	0.0798	0.0065	0.0052	-0.0637	-0.0366	-0.0023
3835.2	-4.0	0.0789	0.0080	0.0186	-0.0584	-0.0370	-0.0016
3835.2	-2.0	0.0778	0.0104	0.0038	-0.0531	-0.0372	-0.0033
3830.4	0.0	0.0779	0.0124	0.0087	-0.0476	-0.0399	-0.0064
3830.4	2.0	0.0790	0.0128	0.0136	-0.0397	-0.0427	-0.0111

Run# 155

Dynamic Pressure (N/m ²)	Angle of Attack (deg)	D/q (m ²)	L/q (m ²)	SF/q (m ²)	PM/q (m ³)	YM/q (m ³)	RM/q (m ³)
1915.2	0.0	0.0769	0.0144	0.0109	-0.0357	-0.0359	-0.0110
2877.6	0.0	0.0807	0.0172	0.0110	-0.0402	-0.0391	-0.0095
3835.2	-8.0	0.0840	0.0108	0.0128	-0.0718	-0.0391	-0.0012
3863.9	-6.0	0.0835	0.0128	0.0111	-0.0657	-0.0379	-0.0013
3863.9	-4.0	0.0835	0.0135	0.0115	-0.0566	-0.0375	-0.0003
3859.1	-2.0	0.0830	0.0169	0.0103	-0.0514	-0.0368	-0.0013
3830.4	0.0	0.0842	0.0117	0.0117	-0.0454	-0.0402	-0.0048
3840.0	2.0	0.0853	0.0217	0.0151	-0.0383	-0.0440	-0.0085
1915.2	0.0	0.0769	0.0144	0.0109	-0.0357	-0.0359	-0.0110
2877.6	0.0	0.0807	0.0172	0.0110	-0.0402	-0.0391	-0.0095
3835.2	-8.0	0.0840	0.0108	0.0128	-0.0718	-0.0391	-0.0012
3863.9	-6.0	0.0835	0.0128	0.0111	-0.0657	-0.0379	-0.0013
3863.9	-4.0	0.0835	0.0135	0.0115	-0.0566	-0.0375	-0.0003
3859.1	-2.0	0.0830	0.0169	0.0103	-0.0514	-0.0368	-0.0013
3830.4	0.0	0.0842	0.0197	0.0117	-0.0454	-0.0402	-0.0048
3840.0	2.0	0.0853	0.0217	0.0151	-0.0383	-0.0440	-0.0085

Run# 156

Dynamic Pressure (N/m ²)	Angle of Attack (deg)	D/q (m ²)	L/q (m ²)	SF/q (m ²)	PM/q (m ³)	YM/q (m ³)	RM/q (m ³)
1915.2	0.0	0.0704	0.0172	0.0149	-0.0378	-0.0350	-0.0085
2848.9	0.0	0.0735	0.0194	0.0211	-0.0409	-0.0386	-0.0085
3830.4	-8.0	0.0771	0.0066	0.0118	-0.0717	-0.0394	-0.0019
3816.0	-6.0	0.0762	0.0104	0.0138	-0.0644	-0.0382	0.0022
3796.9	-4.0	0.0759	0.0132	0.0170	-0.0568	-0.0372	0.0015
3825.6	-2.0	0.0762	0.0178	0.0199	-0.0517	-0.0381	0.0005
3792.1	0.0	0.0766	0.0204	0.0213	-0.0427	-0.0415	-0.0042
3806.5	2.0	0.0782	0.0229	0.0250	-0.0356	-0.0447	-0.0090

Run# 157

Dynamic Pressure (N/m ²)	Angle of Attack (deg)	D/q (m ²)	L/q (m ²)	SF/q (m ²)	PM/q (m ³)	YM/q (m ³)	RM/q (m ³)
1881.7	0.0	0.0775	0.0137	-0.0009	-0.0352	-0.0337	-0.0115
2872.8	0.0	0.0808	0.0155	-0.0008	-0.0401	-0.0369	-0.0097
3359.1	-8.0	0.0814	0.0077	0.0030	-0.0714	-0.0405	-0.0020
3835.2	-6.0	0.0813	0.0095	-0.0002	-0.0634	-0.0390	0.0001
3840.0	-4.0	0.0826	0.0123	0.0020	-0.0562	-0.0374	-0.0008
3830.4	-2.0	0.0825	0.0143	0.0007	-0.0499	-0.0373	-0.0025
3811.2	0.0	0.0833	0.0156	0.0002	-0.0414	-0.0397	-0.0059
3811.2	2.0	0.0845	0.0173	0.0021	-0.0331	-0.0428	-0.0099

Run# 158

Dynamic Pressure (N/m ²)	Angle of Attack (deg)	D/q (m ²)	L/q (m ²)	SF/q (m ²)	PM/q (m ³)	YM/q (m ³)	RM/q (m ³)
1905.6	0.0	0.0773	0.0182	3.3947	-0.0415	-4.4675	-1.1582
2892.0	0.0	0.0806	0.0171	2.2387	-0.0418	-2.9583	-0.7655
3835.2	-8.0	0.0829	0.0092	1.6916	-0.0711	-2.3080	-0.3473
3840.0	-6.0	0.0828	0.0103	1.6870	-0.0634	-2.2905	-0.4019
3816.0	-4.0	0.0826	0.0118	1.6977	-0.0561	-2.2876	-0.4617
3801.7	-2.0	0.0823	0.0147	1.7040	-0.0493	-2.2793	-0.5217
3806.5	0.0	0.0833	0.0162	1.7049	-0.0414	-2.2589	-0.5803
3820.8	2.0	0.0844	0.0171	1.7012	-0.0327	-2.2318	-0.6373

Run# 159

Dynamic Pressure (N/m ²)	Angle of Attack (deg)	D/q (m ²)	L/q (m ²)	SF/q (m ²)	PM/q (m ³)	YM/q (m ³)	RM/q (m ³)
1934.4	0.0	0.0796	0.0269	0.0147	-0.0370	-0.0348	-0.0098
2868.0	0.0	0.0822	0.0282	0.0119	-0.0413	-0.0386	-0.0075
3820.8	-8.0	0.0850	0.0122	0.0129	-0.0730	-0.0378	0.0017
3825.6	-6.0	0.0844	0.0177	0.0124	-0.0667	-0.0370	0.0033
3835.2	-4.0	0.0842	0.0208	0.0115	-0.0574	-0.0366	0.0015
3844.8	-2.0	0.0846	0.0258	0.0137	-0.0523	-0.0365	-0.0003
3792.1	0.0	0.0853	0.0306	0.0140	-0.0462	-0.0412	-0.0021
3820.8	2.0	0.0872	0.0343	0.0151	-0.0391	-0.0421	-0.0069

Run# 160

Dynamic Pressure: (N/m ²)	Angle of Attack (deg)	D/q (m ²)	L/q (m ²)	SF/q (m ²)	PM/q (m ³)	YM/q (m ³)	RM/q (m ³)
1934.4	0.0	0.0837	0.0301	0.0156	-0.0372	-0.0369	-0.0102
2896.7	0.0	0.0871	0.0310	0.0154	-0.0401	-0.0388	-0.0083
3825.6	-8.0	0.0893	0.0153	0.0155	-0.0713	-0.0372	0.0001
3816.0	-6.0	0.0888	0.0202	0.0150	-0.0650	-0.0376	0.0014
3816.0	-4.0	0.0887	0.0227	0.0170	-0.0552	-0.0360	-0.0006
3816.0	-2.0	0.0892	0.0280	0.0149	-0.0504	-0.0374	-0.0015
3796.9	0.0	0.0900	0.0319	0.0171	-0.0428	-0.0403	-0.0057
3849.6	2.0	0.0921	0.0370	0.0195	-0.0372	-0.0434	-0.0093

Run# 161

Dynamic Pressure (N/m ²)	Angle of Attack (deg)	D/q (m ²)	L/q (m ²)	SF/q (m ²)	PM/q (m ³)	YM/q (m ³)	RM/q (m ³)
1967.9	0.0	0.0717	0.0264	0.0113	-0.0403	-0.0351	-0.0087
2868.0	0.0	0.0741	0.0268	0.0121	-0.0426	-0.0379	-0.0088
3849.6	-8.0	0.0788	0.0067	0.0141	-0.0738	-0.0393	0.0018
3863.9	-6.0	0.0776	0.0134	0.0138	-0.0686	-0.0379	0.0042
3849.6	-4.0	0.0770	0.0162	0.0128	-0.0579	-0.0378	0.0013
3825.6	-2.0	0.0770	0.0213	0.0126	-0.0507	-0.0382	-0.0002
3816.0	0.0	0.0775	0.0249	0.0113	-0.0415	-0.0402	-0.0039
3816.0	2.0	0.0790	0.0300	0.0171	-0.0335	-0.0422	-0.0082

Run# 162

Dynamic Pressure (N/m ²)	Angle of Attack (deg)	D/q (m ²)	L/q (m ²)	SF/q (m ²)	PM/q (m ³)	YM/q (m ³)	RM/q (m ³)
1915.2	0.0	0.0704	0.0314	3.3622	-0.0425	-4.4448	-1.1570
2882.4	0.0	0.0744	0.0289	2.2391	-0.0416	-2.9675	-0.7716
3849.6	-8.0	0.0782	0.0080	1.6790	-0.0734	-2.2998	-0.3465
3844.8	-6.0	0.0771	0.0140	1.6816	-0.0674	-2.2871	-0.4018
3844.8	-4.0	0.0767	0.0177	1.6795	-0.0582	-2.2708	-0.4593
3825.6	-2.0	0.0766	0.0224	1.6878	-0.0500	-2.2649	-0.5192
3835.2	0.0	0.0777	0.0263	1.6829	-0.0412	-2.2427	-0.5761
3830.4	2.0	0.0791	0.0310	1.6857	-0.0324	-2.2267	-0.6382

Run# 163

Dynamic Pressure (N/m ²)	Angle of Attack (deg)	D/q (m ²)	L/q (m ²)	SF/q (m ²)	PM/q (m ³)	YM/q (m ³)	RM/q (m ³)
1920.0	0.0	0.0806	0.0303	0.0097	-0.0430	-0.0340	-0.0077
2867.2	0.0	0.0840	0.0299	0.0088	-0.0419	-0.0363	-0.0073
3853.9	-8.0	0.0873	0.0121	0.0098	-0.0728	-0.0401	-0.0032
3849.6	-6.0	0.0863	0.0173	0.0107	-0.0659	-0.0391	-0.0025
3840.0	-4.0	0.0862	0.0209	0.0092	-0.0571	-0.0371	-0.0024
3840.0	-2.0	0.0864	0.0254	0.0098	-0.0510	-0.0401	-0.0038
3844.8	0.0	0.0873	0.0281	0.0120	-0.0415	-0.0385	-0.0070
3835.2	2.0	0.0887	0.0312	0.0129	-0.0329	-0.0411	-0.0112

Run# 164

Dynamic Pressure (N/m ²)	Angle of Attack (deg)	D/q (m ²)	L/q (m ²)	SF/q (m ²)	PM/q (m ³)	YM/q (m ³)	RM/q (m ³)
1920.0	0.0	0.0778	0.0155	0.0120	-0.0388	-0.0360	-0.0087
2868.0	0.0	0.0819	0.0172	0.0129	-0.0418	-0.0392	-0.0078
3825.6	-8.0	0.0839	0.0088	0.0144	-0.0718	-0.0388	0.0029
3849.6	-6.0	0.0837	0.0103	0.0120	-0.0637	-0.0390	0.0035
3825.6	-4.0	0.0835	0.0110	0.0122	-0.0554	-0.0370	-0.0014
3820.8	-2.0	0.0834	0.0146	0.0115	-0.0500	-0.0384	-0.0002
3806.5	0.0	0.0845	0.0180	0.0125	-0.0451	-0.0412	-0.0022
3806.5	2.0	0.0864	0.0196	0.0147	-0.0376	-0.0441	-0.0071

Run# 165

Dynamic Pressure (N/m ²)	Angle of Attack (deg)	D/q (m ²)	L/q (m ²)	SF/q (m ²)	PM/q (m ³)	YM/q (m ³)	RM/q (m ³)
1910.4	0.0	0.0722	0.0231	0.0151	-0.0349	-0.0351	-0.0110
2877.6	0.0	0.0757	0.0264	0.0156	-0.0412	-0.0379	-0.0085
3816.0	-8.0	0.0794	0.0049	0.0152	-0.0713	-0.0400	0.0024
3806.5	-6.0	0.0783	0.0095	0.0158	-0.0628	-0.0383	0.0032
3825.6	-4.0	0.0778	0.0143	0.0149	-0.0554	-0.0371	0.0020
3818.0	-2.0	0.0777	0.0207	0.0154	-0.0494	-0.0371	0.0001
3830.4	0.0	0.0792	0.0267	0.0139	-0.0442	-0.0399	-0.0025
3811.2	2.0	0.0806	0.0313	0.0182	-0.0363	-0.0422	-0.0085

Run# 166

Dynamic Pressure (N/m ²)	Angle of Attack (deg)	D/q (m ²)	L/q (m ²)	SF/q (m ²)	PM/q (m ³)	YM/q (m ³)	RM/q (m ³)
1948.7	0.0	0.0788	0.0269	0.0112	-0.0368	-0.0354	-0.0093
2896.7	0.0	0.0818	0.0286	0.0129	-0.0419	-0.0373	-0.0080
3844.8	-8.0	0.0846	0.0098	0.0134	-0.0730	-0.0395	0.0022
3835.2	-6.0	0.0837	0.0147	0.0128	-0.0652	-0.0376	0.0037
3830.4	-4.0	0.0836	0.0186	0.0117	-0.0562	-0.0374	0.0031
3811.2	-2.0	0.0840	0.0246	0.0112	-0.0508	-0.0381	0.0025
3830.4	0.0	0.0851	0.0296	0.0136	-0.0440	-0.0396	-0.0017
3816.0	2.0	0.0865	0.0332	0.0148	-0.0359	-0.0432	-0.0059

Run# 167

Dynamic Pressure (N/m ²)	Angle of Attack (deg)	D/q (m ²)	L/q (m ²)	SF/q (m ²)	PM/q (m ³)	YM/q (m ³)	RM/q (m ³)
1934.4	0.0	0.0770	0.0113	0.0133	-0.0359	-0.0354	-0.0115
2896.7	0.0	0.0809	0.0140	0.0150	-0.0415	-0.0375	-0.0092
3840.0	-8.0	0.0843	0.0059	0.0147	-0.0709	-0.0393	0.0020
3844.8	-6.0	0.0835	0.0075	0.0143	-0.0634	-0.0376	0.0025
3863.9	-4.0	0.0835	0.0090	0.0143	-0.0547	-0.0373	0.0013
3844.8	-2.0	0.0830	0.0111	0.0133	-0.0489	-0.0376	-0.0014
3830.4	0.0	0.0835	0.0144	0.0158	-0.0429	-0.0402	-0.0041
3835.2	2.0	0.0850	0.0164	0.0177	-0.0365	-0.0431	-0.0083

Run# 168

Dynamic Pressure (N/m ²)	Angle of Attack (deg)	D/q (m ²)	L/q (m ²)	SF/q (m ²)	PM/q (m ³)	YM/q (m ³)	RM/q (m ³)
1934.4	0.0	0.0768	0.0235	0.0136	-0.0395	-0.0349	-0.0096
2920.7	0.0	0.0801	0.0236	0.0146	-0.0424	-0.0374	-0.0079
3844.8	-8.0	0.0841	0.0046	0.0132	-0.0728	-0.0385	0.0014
3840.0	-6.0	0.0832	0.0100	0.0134	-0.0659	-0.0377	0.0026
3816.0	-4.0	0.0825	0.0131	0.0124	-0.0567	-0.0375	0.0016
3830.4	-2.0	0.0819	0.0186	0.0132	-0.0501	-0.0375	-0.0007
3820.8	0.0	0.0828	0.0234	0.0147	-0.0434	-0.0397	-0.0041
3787.3	2.0	0.0874	0.0316	0.0160	-0.0358	-0.0425	-0.0078

Run# 169

Dynamic Pressure (N/m ²)	Angle of Attack (deg)	D/q (m ²)	L/q (m ²)	SF/q (m ²)	PM/q (m ³)	YM/q (m ³)	RM/q (m ³)
1939.1	0.0	0.0801	0.0184	0.0135	-0.0448	-0.0348	-0.0047
2915.9	0.0	0.0824	0.0142	0.0146	-0.0425	-0.0378	-0.0078
3840.0	-8.0	0.0853	0.0036	0.0126	-0.0672	-0.0396	-0.0003
3849.6	-6.0	0.0850	0.0053	0.0134	-0.0589	-0.0375	0.0004
3878.3	-4.0	0.0850	0.0068	0.0134	-0.0506	-0.0376	-0.0003
3854.3	-2.0	0.0846	0.0093	0.0148	-0.0442	-0.0377	-0.0030
3863.9	0.0	0.0851	0.0115	0.0143	-0.0376	-0.0400	-0.0060
3835.2	2.0	0.0863	0.0136	0.0173	-0.0302	-0.0433	-0.0101

Run# 170

Dynamic Pressure (N/m ²)	Angle of Attack (deg)	D/q (m ²)	L/q (m ²)	SF/q (m ²)	PM/q (m ³)	YM/q (m ³)	RM/q (m ³)
1934.4	0.0	0.0690	0.0129	0.0101	-0.0384	-0.0344	-0.0105
2872.8	0.0	0.0726	0.0155	0.0125	-0.0438	-0.0368	-0.0091
3844.8	-8.0	0.0788	-0.0053	0.0141	-0.0667	-0.0377	-0.0028
3840.0	-6.0	0.0768	-0.0008	0.0145	-0.0593	-0.0371	-0.0022
3820.8	-4.0	0.0759	0.0021	0.0128	-0.0492	-0.0365	-0.0035
3849.6	-2.0	0.0753	0.0077	0.0126	-0.0440	-0.0376	-0.0048
3825.6	0.0	0.0753	0.0114	0.0129	-0.0369	-0.0396	-0.0084
3830.4	2.0	0.0769	0.0158	0.0161	-0.0291	-0.0422	-0.0125

Run# 171

Dynamic Pressure (N/m ²)	Angle of Attack (deg)	D/q (m ²)	L/q (m ²)	SF/q (m ²)	PM/q (m ³)	YM/q (m ³)	RM/q (m ³)
1900.8	0.0	0.0768	0.0131	0.0147	-0.0366	-0.0340	-0.0108
2877.6	0.0	0.0805	0.0150	0.0139	-0.0412	-0.0372	-0.0087
3873.5	-8.0	0.0841	0.0078	0.0127	-0.0727	-0.0387	0.0012
3854.3	-6.0	0.0834	0.0093	0.0125	-0.0638	-0.0372	0.0022
3849.6	-4.0	0.0832	0.0107	0.0119	-0.0559	-0.0365	0.0016
3844.8	-2.0	0.0832	0.0131	0.0123	-0.0498	-0.0366	-0.0005
3835.2	0.0	0.0837	0.0150	0.0143	-0.0420	-0.0398	-0.0042
3830.4	2.0	0.0850	0.0160	0.0161	-0.0337	-0.0427	-0.0090

Run# 172

Dynamic Pressure (N/m ²)	Angle of Attack (deg)	D/q (m ²)	L/q (m ²)	SF/q (m ²)	PM/q (m ³)	YM/q (m ³)	RM/q (m ³)
1924.8	0.0	0.0693	0.0132	0.0129	-0.0362	-0.0356	-0.0104
2868.0	0.0	0.0723	0.0143	0.0132	-0.0414	-0.0375	-0.0088
3825.6	-8.0	0.0786	-0.0026	0.0142	-0.0723	-0.0391	0.0025
3868.7	-6.0	0.0770	0.0020	0.0146	-0.0655	-0.0379	0.0026
3835.2	-4.0	0.0761	0.0056	0.0133	-0.0559	-0.0376	0.0006
3816.0	-2.0	0.0757	0.0111	0.0134	-0.0508	-0.0381	-0.0010
3811.2	0.0	0.0757	0.0149	0.0138	-0.0431	-0.0399	-0.0045
3820.8	2.0	0.0777	0.0179	0.0164	-0.0347	-0.0426	-0.0088

Run# 173

Dynamic Pressure (N/m ²)	Angle of Attack (deg)	D/q (m ²)	L/q (m ²)	SF/q (m ²)	PM/q (m ³)	YM/q (m ³)	RM/q (m ³)
1929.6	0.0	0.0768	0.0138	0.0134	-0.0377	-0.0352	-0.0090
2872.8	0.0	0.0801	0.0155	0.0150	-0.0410	-0.0375	-0.0078
3873.5	-8.0	0.0838	0.0075	0.0138	-0.0713	-0.0389	0.0009
3835.2	-6.0	0.0832	0.0093	0.0130	-0.0632	-0.0375	0.0022
3859.1	-4.0	0.0829	0.0106	0.0126	-0.0561	-0.0370	0.0015
3840.0	-2.0	0.0829	0.0139	0.0124	-0.0505	-0.0374	-0.0004
3840.0	0.0	0.0834	0.0156	0.0148	-0.0432	-0.0386	-0.0030
3840.0	2.0	0.0853	0.0166	0.0169	-0.0347	-0.0430	-0.0080

Run# 174

Dynamic Pressure (N/m ²)	Angle of Attack (deg)	D/q (m ²)	L/q (m ²)	SF/q (m ²)	PM/q (m ³)	YM/q (m ³)	RM/q (m ³)
1929.6	0.0	0.0710	0.0071	0.0129	-0.0371	-0.0361	-0.0105
2896.7	0.0	0.0740	0.0088	0.0140	-0.0413	-0.0366	-0.0081
3835.2	-8.0	0.0776	0.0020	0.0153	-0.0706	-0.0381	0.0008
3849.6	-6.0	0.0770	0.0036	0.0156	-0.0636	-0.0378	0.0019
3849.6	-4.0	0.0766	0.0058	0.0149	-0.0576	-0.0372	0.0011
3844.8	-2.0	0.0765	0.0082	0.0130	-0.0524	-0.0377	-0.0005
3820.8	0.0	0.0774	0.0087	0.0153	-0.0426	-0.0392	-0.0053
3835.2	2.0	0.0791	0.0092	0.0175	-0.0345	-0.0428	-0.0091

ORIGINAL PAGE IS
OF POOR QUALITY

Run# 175

Dynamic Pressure (N/m ²)	Angle of Attack (deg)	D/q (m ²)	L/q (m ²)	SF/q (m ²)	PM/q (m ³)	YM/q (m ³)	RM/q (m ³)
1929.6	0.0	0.0703	0.0062	0.0115	-0.0356	-0.0341	-0.0097
2863.2	0.0	0.0739	0.0082	0.0143	-0.0403	-0.0370	-0.0097
3840.0	-8.0	0.0777	0.0023	0.0159	-0.0709	-0.0384	-0.0020
3854.3	-6.0	0.0772	0.0033	0.0144	-0.0628	-0.0378	-0.0015
3844.8	-4.0	0.0764	0.0046	0.0158	-0.0554	-0.0361	-0.0024
3849.6	-2.0	0.0766	0.0075	0.0131	-0.0503	-0.0371	-0.0041
3844.8	0.0	0.0773	0.0087	0.0147	-0.0424	-0.0391	-0.0076
3830.4	2.0	0.0786	0.0088	0.0179	-0.0334	-0.0420	-0.0123

Run# 176

Dynamic Pressure (N/m ²)	Angle of Attack (deg)	D/q (m ²)	L/q (m ²)	SF/q (m ²)	PM/q (m ³)	YM/q (m ³)	RM/q (m ³)
1905.6	0.0	0.0833	0.0124	-0.0009	-0.0365	-0.0339	-0.0111
2868.0	0.0	0.0851	0.0161	0.0008	-0.0391	-0.0380	-0.0099
3816.0	-8.0	0.0882	-0.0010	0.0047	-0.0705	-0.0408	-0.0022
3830.4	-6.0	0.0877	0.0028	0.0014	-0.0613	-0.0379	-0.0009
3811.2	-4.0	0.0872	0.0068	-0.0007	-0.0539	-0.0378	-0.0022
3840.0	-2.0	0.0876	0.0120	-0.0008	-0.0472	-0.0379	-0.0046
3844.8	0.0	0.0886	0.0141	-0.0005	-0.0391	-0.0389	-0.0080
3825.6	2.0	0.0910	0.0183	0.0010	-0.0310	-0.0419	-0.0116

Run# 177

Dynamic Pressure (N/m ²)	Angle of Attack (deg)	D/q (m ²)	L/q (m ²)	SF/q (m ²)	PM/q (m ³)	YM/q (m ³)	RM/q (m ³)
1924.8	0.0	0.0848	0.0203	-0.0021	-0.0381	-0.0334	-0.0099
2892.0	0.0	0.0889	0.0214	-0.0011	-0.0397	-0.0366	-0.0099
3830.4	-8.0	0.0916	0.0078	0.0014	-0.0702	-0.0396	-0.0008
3825.6	-8.0	0.0912	0.0086	-0.0019	-0.0597	-0.0369	0.0030
3820.8	-4.0	0.0910	0.0123	-0.0019	-0.0539	-0.0378	0.0005
3816.0	-2.0	0.0910	0.0176	-0.0021	-0.0476	-0.0383	-0.0012
3835.2	0.0	0.0922	0.0202	-0.0006	-0.0390	-0.0394	-0.0047
3820.8	2.0	0.0941	0.0235	0.0029	-0.0310	-0.0419	-0.0086

Run# 178

Dynamic Pressure (N/m ²)	Angle of Attack (deg)	D/q (m ²)	L/q (m ²)	SF/q (m ²)	PM/q (m ³)	YM/q (m ³)	RM/q (m ³)
1920.0	0.0	0.0869	0.0271	0.0090	-0.0392	-0.0351	-0.0114
2858.4	0.0	0.0904	0.0272	0.0093	-0.0415	-0.0379	-0.0100
3835.2	-8.0	0.0926	0.0132	0.0099	-0.0711	-0.0383	0.0000
3849.6	-8.0	0.0923	0.0156	0.0099	-0.0614	-0.0383	0.0011
3835.2	-4.0	0.0921	0.0183	0.0085	-0.0541	-0.0373	-0.0001
3854.3	-2.0	0.0926	0.0223	0.0075	-0.0485	-0.0380	-0.0024
3840.0	0.0	0.0921	0.0173	0.0039	-0.0401	-0.0398	-0.0070
3840.0	2.0	0.0936	0.0204	0.0029	-0.0325	-0.0417	-0.0097

Run# 179

Dynamic Pressure (N/m ²)	Angle of Attack (deg)	D/q (m ²)	L/q (m ²)	SF/q (m ²)	PM/q (m ³)	YM/q (m ³)	RM/q (m ³)
1939.1	0.0	0.0853	0.0220	0.0067	-0.0408	-0.0352	-0.0105
2858.0	0.0	0.0883	0.0208	0.0088	-0.0405	-0.0376	-0.0107
3859.1	-8.0	0.0913	-0.0002	0.0067	-0.0688	-0.0397	-0.0025
3840.0	-6.0	0.0901	0.0041	0.0059	-0.0615	-0.0375	-0.0012
3844.8	-4.0	0.0891	0.0080	0.0038	-0.0567	-0.0376	-0.0022
3835.2	-2.0	0.0894	0.0126	0.0041	-0.0499	-0.0379	-0.0043
3820.8	0.0	0.0898	0.0173	0.0054	-0.0436	-0.0384	-0.0075
3801.7	2.0	0.0919	0.0211	0.0121	-0.0344	-0.0432	-0.0129

Run# 180

Dynamic Pressure (N/m ²)	Angle of Attack (deg)	D/q (m ²)	L/q (m ²)	SF/q (m ²)	PM/q (m ³)	YM/q (m ³)	RM/q (m ³)
1934.4	0.0	0.0830	0.0138	-0.0014	-0.0428	-0.0341	-0.0113
2858.4	0.0	0.0856	0.0110	-0.0008	-0.0402	-0.0375	-0.0103
3835.2	-8.0	0.0904	-0.0125	0.0035	-0.0686	-0.0404	-0.0019
3835.2	-6.0	0.0890	-0.0078	0.0017	-0.0603	-0.0381	-0.0016
3835.2	-4.0	0.0883	-0.0014	0.0014	-0.0550	-0.0382	-0.0020
3811.2	-2.0	0.0884	0.0061	-0.0008	-0.0503	-0.0378	-0.0031
3820.8	0.0	0.0880	0.0102	0.0017	-0.0432	-0.0403	-0.0072
3816.0	2.0	0.0887	0.0120	0.0042	-0.0345	-0.0422	-0.0128

ORIGINAL PAGE IS
OF POOR QUALITY

Run# 181

Dynamic Pressure (N/m ²)	Angle of Attack (deg)	D/q (m ²)	L/q (m ²)	SF/q (m ²)	PM/q (m ³)	YM/q (m ³)	RM/q (m ³)
1943.9	0.0	0.0851	0.0258	0.0121	-0.0441	-0.0346	-0.0098
2848.9	0.0	0.0879	0.0214	0.0122	-0.0400	-0.0377	-0.0099
3859.1	-8.0	0.0916	-0.0046	0.0054	-0.0688	-0.0390	-0.0043
3859.1	-6.0	0.0904	-0.0009	0.0038	-0.0602	-0.0366	-0.0035
3854.3	-4.0	0.0898	0.0039	0.0014	-0.0542	-0.0366	-0.0032
3859.1	-2.0	0.0901	0.0092	-0.0014	-0.0491	-0.0373	-0.0053
3835.2	0.0	0.0907	0.0137	0.0000	-0.0424	-0.0392	-0.0089
3830.4	2.0	0.0915	0.0159	-0.0012	-0.0345	-0.0414	-0.0125

Run# 186

Dynamic Pressure (N/m ²)	Angle of Attack (deg)	D/q (m ²)	L/q (m ²)	SF/q (m ²)	PM/q (m ³)	YM/q (m ³)	RM/q (m ³)
1948.7	0.0	0.0929	0.0288	0.0114	-0.0443	-0.0382	-0.0088
2906.3	0.0	0.0984	0.0286	0.0112	-0.0436	-0.0396	-0.0070
3825.6	-8.0	0.1002	0.0100	0.0064	-0.0700	-0.0432	0.0003
3820.8	-6.0	0.1002	0.0149	0.0043	-0.0631	-0.0412	0.0020
3825.6	-4.0	0.1002	0.0203	0.0043	-0.0562	-0.0383	-0.0002
3811.2	-2.0	0.1013	0.0263	0.0071	-0.0518	-0.0422	-0.0017
3844.8	0.0	0.1031	0.0300	0.0079	-0.0451	-0.0424	-0.0060
3849.6	2.0	0.1057	0.0339	0.0107	-0.0379	-0.0452	-0.0106

Run# 187

Dynamic Pressure (N/m ²)	Angle of Attack (deg)	D/q (m ²)	L/q (m ²)	SF/q (m ²)	PM/q (m ³)	YM/q (m ³)	RM/q (m ³)
1939.1	0.0	0.0821	0.0349	0.0126	-0.0440	-0.0370	-0.0074
2872.8	0.0	0.0856	0.0331	0.0136	-0.0429	-0.0389	-0.0076
3854.3	-8.0	0.0872	0.0102	0.0153	-0.0738	-0.0401	0.0018
3849.6	-6.0	0.0867	0.0168	0.0173	-0.0667	-0.0383	0.0028
3849.6	-4.0	0.0872	0.0224	0.0170	-0.0587	-0.0392	0.0018
3863.9	-2.0	0.0884	0.0284	0.0163	-0.0519	-0.0386	0.0007
3835.2	0.0	0.0900	0.0335	0.0188	-0.0443	-0.0407	-0.0037
3830.4	2.0	0.0922	0.0381	0.0202	-0.0375	-0.0438	-0.0076

Run# 188

Dynamic Pressure (N/m ²)	Angle of Attack (deg)	D/q (m ²)	L/q (m ²)	SF/q (m ²)	PM/q (m ³)	YM/q (m ³)	RM/q (m ³)
1948.7	0.0	0.0840	0.0379	0.0135	-0.0472	-0.0362	-0.0055
2868.0	0.0	0.0879	0.0369	0.0168	-0.0472	-0.0392	-0.0056
3854.3	-8.0	0.0915	0.0126	0.0125	-0.0737	-0.0411	0.0030
3835.2	-6.0	0.0907	0.0187	0.0117	-0.0671	-0.0391	0.0036
3840.0	-4.0	0.0908	0.0234	0.0124	-0.0589	-0.0390	0.0018
3840.0	-2.0	0.0910	0.0287	0.0144	-0.0526	-0.0388	0.0003
3825.8	0.0	0.0923	0.0343	0.0165	-0.0449	-0.0413	-0.0031
3806.5	2.0	0.0943	0.0393	0.0185	-0.0370	-0.0432	-0.0076

Run# 189

Dynamic Pressure (N/m ²)	Angle of Attack (deg)	D/q (m ²)	L/q (m ²)	SF/q (m ²)	PM/q (m ³)	YM/q (m ³)	RM/q (m ³)
1929.6	0.0	0.0918	0.0424	0.0106	-0.0442	-0.0364	-0.0072
2887.2	0.0	0.0951	0.0427	0.0134	-0.0489	-0.0411	-0.0061
3849.6	-8.0	0.0965	0.0153	0.0103	-0.0740	-0.0408	0.0037
3854.3	-6.0	0.0957	0.0202	0.0111	-0.0660	-0.0389	0.0031
3835.2	-4.0	0.0959	0.0256	0.0111	-0.0583	-0.0384	0.0019
3816.0	-2.0	0.0966	0.0316	0.0105	-0.0521	-0.0398	-0.0008
3811.2	0.0	0.0982	0.0362	0.0112	-0.0439	-0.0422	-0.0044
3835.2	2.0	0.1002	0.0421	0.0144	-0.0370	-0.0429	-0.0086

Run# 190

Dynamic Pressure (N/m ²)	Angle of Attack (deg)	D/q (m ²)	L/q (m ²)	SF/q (m ²)	PM/q (m ³)	YM/q (m ³)	RM/q (m ³)
1920.0	0.0	0.0927	0.0241	0.0130	-0.0426	-0.0370	-0.0076
2858.4	0.0	0.0962	0.0260	0.0114	-0.0466	-0.0392	-0.0071
3863.9	-8.0	0.0977	0.0039	0.0106	-0.0731	-0.0420	0.0030
3840.0	-6.0	0.0973	0.0098	0.0102	-0.0659	-0.0409	0.0043
3854.3	-4.0	0.0972	0.0137	0.0100	-0.0578	-0.0380	0.0023
3840.0	-2.0	0.0978	0.0184	0.0102	-0.0507	-0.0414	-0.0004
3806.5	0.0	0.0993	0.0226	0.0113	-0.0425	-0.0439	-0.0044
3816.0	2.0	0.1005	0.0276	0.0128	-0.0358	-0.0443	-0.0077

Run# 191

Dynamic Pressure (N/m ²)	Angle of Attack (deg)	D/q (m ²)	L/q (m ²)	SF/q (m ²)	PM/q (m ³)	YM/q (m ³)	RM/q (m ³)
1920.0	0.0	0.0704	0.0107	0.0125	-0.0436	-0.0355	-0.0099
2896.7	0.0	0.0728	0.0114	0.0127	-0.0464	-0.0370	-0.0078
3844.8	-8.0	0.0762	0.0027	0.0124	-0.0732	-0.0369	-0.0008
3811.2	-6.0	0.0750	0.0050	0.0119	-0.0669	-0.0351	0.0005
3820.8	-4.0	0.0749	0.0068	0.0109	-0.0596	-0.0361	0.0006
3811.2	-2.0	0.0753	0.0082	0.0119	-0.0520	-0.0367	-0.0013
3801.7	0.0	0.0755	0.0094	0.0130	-0.0444	-0.0395	-0.0043
3825.6	2.0	0.0778	0.0108	0.0158	-0.0378	-0.0427	-0.0079

Run# 192

Dynamic Pressure (N/m ²)	Angle of Attack (deg)	D/q (m ²)	L/q (m ²)	SF/q (m ²)	PM/q (m ³)	YM/q (m ³)	RM/q (m ³)
1943.9	0.0	0.0712	0.0103	0.0137	-0.0442	-0.0366	-0.0099
2868.0	0.0	0.0740	0.0123	0.0144	-0.0478	-0.0385	-0.0076
3811.2	-8.0	0.0764	0.0037	0.0131	-0.0746	-0.0389	0.0004
3820.8	-6.0	0.0757	0.0054	0.0125	-0.0677	-0.0382	0.0015
3811.2	-4.0	0.0754	0.0071	0.0130	-0.0599	-0.0376	0.0013
3816.0	-2.0	0.0755	0.0080	0.0120	-0.0519	-0.0380	-0.0008
3820.8	0.0	0.0761	0.0095	0.0143	-0.0448	-0.0405	-0.0038
3787.3	2.0	0.0779	0.0105	0.0180	-0.0371	-0.0434	-0.0086

Run# 193

Dynamic Pressure (N/m ²)	Angle of Attack (deg)	D/q (m ²)	L/q (m ²)	SF/q (m ²)	PM/q (m ³)	YM/q (m ³)	RM/q (m ³)
1939.1	0.0	0.0711	0.0126	0.0133	-0.0468	-0.0351	-0.0074
2892.0	0.0	0.0732	0.0128	0.0140	-0.0482	-0.0368	-0.0071
3863.9	-8.0	0.0766	0.0040	0.0125	-0.0745	-0.0379	0.0022
3849.6	-6.0	0.0755	0.0058	0.0122	-0.0677	-0.0363	0.0021
3859.1	-4.0	0.0750	0.0068	0.0113	-0.0602	-0.0359	0.0008
3840.0	-2.0	0.0758	0.0094	0.0132	-0.0531	-0.0362	-0.0008
3835.2	0.0	0.0762	0.0099	0.0142	-0.0444	-0.0402	-0.0043
3835.2	2.0	0.0772	0.0113	0.0173	-0.0376	-0.0422	-0.0086

Run# 194

Dynamic Pressure: (N/m ²)	Angle of Attack (deg)	D/q (m ²)	L/q (m ²)	SF/q (m ²)	PM/q (m ³)	YM/q (m ³)	RM/q (m ³)
1905.6	0.0	0.0689	0.0119	0.0124	-0.0468	-0.0362	-0.0076
2872.8	0.0	0.0712	0.0119	0.0129	-0.0479	-0.0378	-0.0068
3854.3	-8.0	0.0743	0.0047	0.0122	-0.0759	-0.0382	-0.0002
3854.3	-6.0	0.0736	0.0060	0.0118	-0.0683	-0.0373	0.0021
3854.3	-4.0	0.0732	0.0063	0.0117	-0.0597	-0.0369	0.0011
3840.0	-2.0	0.0734	0.0092	0.0114	-0.0539	-0.0373	0.0010
3835.2	0.0	0.0736	0.0089	0.0133	-0.0444	-0.0393	-0.0036
3816.0	2.0	0.0748	0.0098	0.0153	-0.0366	-0.0429	-0.0067

Run# 195

Dynamic Pressure (N/m ²)	Angle of Attack (deg)	D/q (m ²)	L/q (m ²)	SF/q (m ²)	PM/q (m ³)	YM/q (m ³)	RM/q (m ³)
1934.4	0.0	0.0711	0.0131	0.0138	-0.0460	-0.0356	-0.0086
2868.0	0.0	0.0743	0.0135	0.0136	-0.0479	-0.0374	-0.0071
3840.0	-8.0	0.0763	0.0036	0.0130	-0.0723	-0.0384	0.0007
3854.3	-6.0	0.0756	0.0052	0.0129	-0.0654	-0.0370	0.0021
3854.3	-4.0	0.0761	0.0072	0.0132	-0.0585	-0.0378	0.0011
3863.9	-2.0	0.0763	0.0086	0.0130	-0.0522	-0.0382	-0.0008
3849.6	0.0	0.0774	0.0106	0.0147	-0.0445	-0.0408	-0.0035
3840.0	2.0	0.0784	0.0117	0.0166	-0.0372	-0.0434	-0.0085

Run# 196

Dynamic Pressure (N/m ²)	Angle of Attack (deg)	D/q (m ²)	L/q (m ²)	SF/q (m ²)	PM/q (m ³)	YM/q (m ³)	RM/q (m ³)
1915.2	0.0	0.0701	0.0109	0.0139	-0.0425	-0.0341	-0.0090
2896.7	0.0	0.0739	0.0129	0.0127	-0.0477	-0.0379	-0.0064
3835.2	-8.0	0.0762	0.0039	0.0131	-0.0729	-0.0392	0.0020
3844.8	-6.0	0.0752	0.0060	0.0134	-0.0682	-0.0383	0.0027
3820.8	-4.0	0.0752	0.0075	0.0139	-0.0588	-0.0384	0.0020
3825.6	-2.0	0.0749	0.0095	0.0122	-0.0526	-0.0379	0.0011
3792.1	0.0	0.0765	0.0107	0.0149	-0.0445	-0.0400	-0.0034
3830.4	2.0	0.0771	0.0131	0.0165	-0.0376	-0.0417	-0.0070

Run# 197

Dynamic Pressure (N/m ²)	Angle of Attack (deg)	D/q (m ²)	L/q (m ²)	SF/q (m ²)	PM/q (m ³)	YM/q (m ³)	RM/q (m ³)
1934.4	0.0	0.0701	0.0262	0.0154	-0.0486	-0.0360	-0.0071
2858.4	0.0	0.0735	0.0246	0.0148	-0.0474	-0.0392	-0.0073
3849.6	-8.0	0.0761	0.0058	0.0142	-0.0732	-0.0397	0.0017
3844.8	-6.0	0.0752	0.0106	0.0120	-0.0669	-0.0386	0.0030
3840.0	-4.0	0.0746	0.0137	0.0138	-0.0587	-0.0374	0.0010
3820.8	-2.0	0.0747	0.0184	0.0126	-0.0516	-0.0390	-0.0004
3816.0	0.0	0.0757	0.0214	0.0148	-0.0444	-0.0408	-0.0031
3811.2	2.0	0.0771	0.0251	0.0158	-0.0372	-0.0436	-0.0077

Run# 198

Dynamic Pressure (N/m ²)	Angle of Attack (deg)	D/q (m ²)	L/q (m ²)	SF/q (m ²)	PM/q (m ³)	YM/q (m ³)	RM/q (m ³)
1900.8	0.0	0.0702	0.0250	0.0084	-0.0467	-0.0382	-0.0081
2868.0	0.0	0.0740	0.0239	0.0082	-0.0475	-0.0403	-0.0070
3830.4	-8.0	0.0764	0.0053	0.0125	-0.0733	-0.0432	0.0002
3801.7	-6.0	0.0752	0.0101	0.0103	-0.0653	-0.0407	0.0022
3792.1	-4.0	0.0746	0.0140	0.0097	-0.0591	-0.0401	0.0018
3811.2	-2.0	0.0749	0.0177	0.0081	-0.0517	-0.0411	-0.0001
3811.2	0.0	0.0762	0.0209	0.0079	-0.0443	-0.0434	-0.0026
3811.2	2.0	0.0776	0.0254	0.0104	-0.0375	-0.0450	-0.0067

Run# 199

Dynamic Pressure (N/m ²)	Angle of Attack (deg)	D/q (m ²)	L/q (m ²)	SF/q (m ²)	PM/q (m ³)	YM/q (m ³)	RM/q (m ³)
1948.7	0.0	0.0753	0.0121	0.0183	-0.0448	-0.0367	-0.0084
2872.8	0.0	0.0785	0.0132	0.0195	-0.0485	-0.0391	-0.0078
3854.3	-8.0	0.0809	0.0044	0.0140	-0.0745	-0.0392	0.0016
3844.8	-8.0	0.0802	0.0065	0.0165	-0.0675	-0.0378	0.0036
3830.4	-4.0	0.0801	0.0084	0.0179	-0.0614	-0.0381	0.0025
3844.8	-2.0	0.0806	0.0109	0.0186	-0.0556	-0.0388	0.0004
3840.0	0.0	0.0816	0.0134	0.0209	-0.0496	-0.0416	-0.0021
3825.8	2.0	0.0826	0.0137	0.0208	-0.0415	-0.0446	-0.0066

Run# 200

Dynamic Pressure (N/m ²)	Angle of Attack (deg)	D/q (m ²)	L/q (m ²)	SF/q (m ²)	PM/q (m ³)	YM/q (m ³)	RM/q (m ³)
1929.6	0.0	0.0779	0.0136	0.0187	-0.0455	-0.0359	-0.0099
2882.4	0.0	0.0813	0.0148	0.0198	-0.0495	-0.0387	-0.0082
3820.8	-8.0	0.0825	0.0062	0.0136	-0.0751	-0.0377	0.0001
3849.6	-6.0	0.0823	0.0088	0.0144	-0.0700	-0.0370	0.0016
3840.0	-4.0	0.0829	0.0102	0.0167	-0.0628	-0.0369	-0.0001
3854.3	-2.0	0.0829	0.0130	0.0173	-0.0574	-0.0383	-0.0010
3830.4	0.0	0.0840	0.0147	0.0196	-0.0508	-0.0407	-0.0048
3835.2	2.0	0.0864	0.0161	0.0203	-0.0441	-0.0442	-0.0088

Run# 201									
Dynamic Pressure (N/m ²)	Angle of Attack (deg)	D/q (m ²)	L/q (m ²)	SF/q (m ²)	PM/q (m ³)	YM/q (m ³)	RM/q (m ³)		
1929.6	0.0	0.0719	0.0108	0.0173	-0.0430	-0.0360	-0.0090		
2887.2	0.0	0.0756	0.0125	0.0165	-0.0474	-0.0392	-0.0076		
3854.3	-8.0	0.0787	0.0046	0.0126	-0.0755	-0.0393	0.0007		
3844.8	-6.0	0.0780	0.0066	0.0143	-0.0677	-0.0371	0.0022		
3863.9	-4.0	0.0776	0.0078	0.0146	-0.0610	-0.0374	0.0011		
3840.0	-2.0	0.0774	0.0107	0.0158	-0.0559	-0.0378	-0.0003		
3835.2	0.0	0.0782	0.0115	0.0173	-0.0475	-0.0405	-0.0037		
3840.0	2.0	0.0802	0.0125	0.0183	-0.0390	-0.0436	-0.0081		

Run# 202									
Dynamic Pressure (N/m ²)	Angle of Attack (deg)	D/q (m ²)	L/q (m ²)	SF/q (m ²)	PM/q (m ³)	YM/q (m ³)	RM/q (m ³)		
1915.2	0.0	0.0766	0.0167	-0.0267	-0.0467	-0.0340	-0.0069		
2887.2	0.0	0.0804	0.0186	-0.0263	-0.0499	-0.0370	-0.0050		
3849.6	-8.0	0.0825	0.0124	-0.0064	-0.0835	-0.0459	0.0041		
3863.9	-6.0	0.0817	0.0142	-0.0120	-0.0776	-0.0440	0.0072		
3859.1	-4.0	0.0816	0.0158	-0.0169	-0.0687	-0.0409	0.0045		
3830.4	-2.0	0.0820	0.0167	-0.0216	-0.0574	-0.0393	0.0010		
3840.0	0.0	0.0827	0.0163	-0.0248	-0.0472	-0.0382	-0.0014		
3830.4	2.0	0.0842	0.0163	-0.0296	-0.0387	-0.0385	-0.0047		

Run# 203

Dynamic Pressure (N/m ²)	Angle of Attack (deg)	D/q (m ²)	L/q (m ²)	SF/q (m ²)	PM/q (m ³)	YM/q (m ³)	RM/q (m ³)
1905.8	0.0	0.0742	0.0133	-0.0096	-0.0453	-0.0333	-0.0073
2858.4	0.0	0.0780	0.0162	-0.0101	-0.0503	-0.0372	-0.0059
3844.8	-8.0	0.0798	0.0047	0.0060	-0.0751	-0.0420	0.0010
3849.6	-8.0	0.0788	0.0066	0.0037	-0.0680	-0.0400	0.0029
3840.0	-4.0	0.0787	0.0080	-0.0001	-0.0606	-0.0392	0.0014
3835.2	-2.0	0.0786	0.0114	-0.0034	-0.0540	-0.0385	-0.0004
3825.6	0.0	0.0803	0.0124	-0.0093	-0.0462	-0.0397	-0.0025
3830.4	2.0	0.0816	0.0134	-0.0113	-0.0370	-0.0394	-0.0067

Run# 204

Dynamic Pressure (N/m ²)	Angle of Attack (deg)	D/q (m ²)	L/q (m ²)	SF/q (m ²)	PM/q (m ³)	YM/q (m ³)	RM/q (m ³)
1910.4	0.0	0.0719	0.0109	0.0140	-0.0427	-0.0353	-0.0090
2863.2	0.0	0.0752	0.0127	0.0155	-0.0469	-0.0378	-0.0077
3816.0	-8.0	0.0783	0.0041	0.0152	-0.0739	-0.0389	0.0002
3796.9	-8.0	0.0774	0.0055	0.0156	-0.0666	-0.0373	0.0013
3806.5	-4.0	0.0770	0.0069	0.0161	-0.0591	-0.0377	-0.0010
3806.5	-2.0	0.0771	0.0095	0.0165	-0.0529	-0.0372	-0.0024
3816.0	0.0	0.0781	0.0113	0.0167	-0.0456	-0.0397	-0.0049
3816.0	2.0	0.0795	0.0131	0.0189	-0.0384	-0.0429	-0.0085

Run# 205

Dynamic Pressure (N/m ²)	Angle of Attack (deg)	D/q (m ²)	L/q (m ²)	SF/q (m ²)	PM/q (m ³)	YM/q (m ³)	RM/q (m ³)
1910.4	0.0	0.0712	0.0112	0.0142	-0.0457	-0.0347	-0.0080
2863.2	0.0	0.0749	0.0124	0.0160	-0.0480	-0.0380	-0.0083
3820.8	-8.0	0.0773	0.0050	0.0130	-0.0765	-0.0381	0.0022
3825.8	-6.0	0.0769	0.0062	0.0130	-0.0681	-0.0379	0.0032
3830.4	-4.0	0.0761	0.0073	0.0136	-0.0806	-0.0364	0.0027
3796.9	-2.0	0.0757	0.0098	0.0139	-0.0548	-0.0369	0.0009
3820.8	0.0	0.0775	0.0113	0.0154	-0.0480	-0.0403	-0.0023
3801.7	2.0	0.0792	0.0118	0.0167	-0.0399	-0.0430	-0.0064

Run# 206

Dynamic Pressure (N/m ²)	Angle of Attack (deg)	D/q (m ²)	L/q (m ²)	SF/q (m ²)	PM/q (m ³)	YM/q (m ³)	RM/q (m ³)
1920.0	0.0	0.0732	0.0116	0.0213	-0.0429	-0.0382	-0.0103
2872.8	0.0	0.0759	0.0132	0.0172	-0.0473	-0.0389	-0.0075
3830.4	-8.0	0.0785	0.0041	0.0101	-0.0742	-0.0404	0.0014
3820.8	-6.0	0.0775	0.0062	0.0106	-0.0674	-0.0377	0.0032
3830.4	-4.0	0.0771	0.0074	0.0102	-0.0801	-0.0376	0.0028
3825.6	-2.0	0.0766	0.0092	0.0094	-0.0531	-0.0377	0.0007
3801.7	0.0	0.0779	0.0118	0.0125	-0.0461	-0.0398	-0.0030
3811.2	2.0	0.0795	0.0128	0.0158	-0.0382	-0.0438	-0.0073

ORIGINAL PAGE IS
OF POOR QUALITY

Run# 207

Dynamic Pressure (N/m ²)	Angle of Attack (deg)	D/q (m ²)	L/q (m ²)	SF/q (m ²)	PM/q (m ³)	YM/q (m ³)	RM/q (m ³)
1939.1	0.0	0.0716	0.0099	0.0165	-0.0427	-0.0352	-0.0086
2911.1	0.0	0.0744	0.0113	0.0151	-0.0469	-0.0380	-0.0072
3844.8	-8.0	0.0776	0.0032	0.0157	-0.0743	-0.0376	0.0027
3844.8	-8.0	0.0767	0.0052	0.0152	-0.0671	-0.0370	0.0031
3844.8	-4.0	0.0765	0.0072	0.0146	-0.0602	-0.0373	0.0026
3830.4	-2.0	0.0758	0.0095	0.0147	-0.0544	-0.0375	0.0014
3840.0	0.0	0.0775	0.0109	0.0171	-0.0463	-0.0414	-0.0020
3830.4	2.0	0.0786	0.0114	0.0175	-0.0389	-0.0431	-0.0062

Run# 208

Dynamic Pressure (N/m ²)	Angle of Attack (deg)	D/q (m ²)	L/q (m ²)	SF/q (m ²)	PM/q (m ³)	YM/q (m ³)	RM/q (m ³)
1939.1	0.0	0.0707	0.0218	0.0147	-0.0422	-0.0348	-0.0095
2896.7	0.0	0.0745	0.0233	0.0152	-0.0466	-0.0385	-0.0069
3863.9	-8.0	0.0783	0.0060	0.0162	-0.0749	-0.0375	0.0012
3844.8	-6.0	0.0771	0.0109	0.0134	-0.0682	-0.0373	0.0037
3854.3	-4.0	0.0767	0.0144	0.0149	-0.0606	-0.0370	0.0019
3840.0	-2.0	0.0763	0.0196	0.0141	-0.0557	-0.0380	0.0003
3830.4	0.0	0.0775	0.0240	0.0172	-0.0491	-0.0399	-0.0036
3811.2	2.0	0.0788	0.0273	0.0201	-0.0410	-0.0431	-0.0075

Run# 209

Dynamic Pressure (N/m ²)	Angle of Attack (deg)	D/q (m ²)	L/q (m ²)	SF/q (m ²)	PM/q (m ³)	YM/q (m ³)	RM/q (m ³)
1934.4	0.0	0.0798	0.0200	0.0120	-0.0432	-0.0367	-0.0085
2868.0	0.0	0.0827	0.0209	0.0133	-0.0466	-0.0382	-0.0072
3840.0	-8.0	0.0854	0.0114	0.0119	-0.0741	-0.0393	0.0012
3854.3	-6.0	0.0849	0.0137	0.0110	-0.0681	-0.0380	0.0028
3859.1	-4.0	0.0852	0.0148	0.0112	-0.0596	-0.0372	0.0012
3840.0	-2.0	0.0855	0.0187	0.0117	-0.0549	-0.0383	0.0004
3835.2	0.0	0.0859	0.0213	0.0137	-0.0485	-0.0402	-0.0033
3835.2	2.0	0.0877	0.0224	0.0164	-0.0397	-0.0427	-0.0079

Run# 210

Dynamic Pressure (N/m ²)	Angle of Attack (deg)	D/q (m ²)	L/q (m ²)	SF/q (m ²)	PM/q (m ³)	YM/q (m ³)	RM/q (m ³)
1943.9	0.0	0.0767	0.0172	0.0103	-0.0416	-0.0353	-0.0074
2844.1	0.0	0.0805	0.0197	0.0120	-0.0468	-0.0375	-0.0066
3873.5	-8.0	0.0842	0.0111	0.0110	-0.0737	-0.0374	0.0011
3859.1	-6.0	0.0833	0.0130	0.0104	-0.0672	-0.0384	0.0029
3863.9	-4.0	0.0830	0.0150	0.0102	-0.0607	-0.0369	0.0022
3859.1	-2.0	0.0831	0.0173	0.0104	-0.0552	-0.0373	0.0003
3844.8	0.0	0.0842	0.0199	0.0131	-0.0481	-0.0405	-0.0029
3835.2	2.0	0.0858	0.0212	0.0159	-0.0403	-0.0425	-0.0075

Run# 211

Dynamic Pressure (N/m ²)	Angle of Attack (deg)	D/q (m ²)	L/q (m ²)	SF/q (m ²)	PM/q (m ³)	YM/q (m ³)	RM/q (m ³)
1924.8	0.0	0.0719	0.0176	0.0127	-0.0420	-0.0351	-0.0108
2872.8	0.0	0.0756	0.0200	0.0091	-0.0473	-0.0385	-0.0080
3873.5	-8.0	0.0796	0.0024	0.0125	-0.0756	-0.0397	0.0037
3835.2	-8.0	0.0783	0.0068	0.0123	-0.0683	-0.0385	0.0040
3844.8	-4.0	0.0777	0.0111	0.0094	-0.0618	-0.0384	0.0032
3830.4	-2.0	0.0779	0.0161	0.0114	-0.0560	-0.0386	0.0011
3825.6	0.0	0.0786	0.0200	0.0130	-0.0488	-0.0418	-0.0025
3801.7	2.0	0.0807	0.0228	0.0174	-0.0405	-0.0437	-0.0074

Run# 212

Dynamic Pressure (N/m ²)	Angle of Attack (deg)	D/q (m ²)	L/q (m ²)	SF/q (m ²)	PM/q (m ³)	YM/q (m ³)	RM/q (m ³)
1939.1	0.0	0.0791	0.0289	-0.0323	-0.0475	-0.0345	-0.0059
2832.4	0.0	0.0826	0.0306	-0.0336	-0.0516	-0.0382	-0.0050
3868.7	-8.0	0.0854	0.0174	-0.0136	-0.0861	-0.0486	0.0054
3854.3	-6.0	0.0847	0.0214	-0.0189	-0.0792	-0.0465	0.0075
3830.4	-4.0	0.0847	0.0231	-0.0230	-0.0657	-0.0423	0.0029
3825.6	-2.0	0.0852	0.0281	-0.0296	-0.0611	-0.0419	0.0020
3820.8	0.0	0.0860	0.0296	-0.0341	-0.0515	-0.0408	0.0000
3820.8	2.0	0.0875	0.0313	-0.0350	-0.0416	-0.0386	-0.0042

Run# 213

Dynamic Pressure (N/m ²)	Angle of Attack (deg)	D/q (m ²)	L/q (m ²)	SF/q (m ²)	PM/q (m ³)	YM/q (m ³)	RM/q (m ³)
1920.0	0.0	0.0825	0.0220	-0.0014	-0.0452	-0.0360	-0.0060
2911.1	0.0	0.0865	0.0243	-0.0011	-0.0497	-0.0392	-0.0052
3835.2	-8.0	0.0885	0.0164	0.0071	-0.0767	-0.0410	0.0033
3840.0	-6.0	0.0880	0.0173	0.0054	-0.0684	-0.0405	0.0034
3820.8	-4.0	0.0875	0.0193	0.0016	-0.0625	-0.0398	0.0033
3825.6	-2.0	0.0884	0.0216	0.0015	-0.0563	-0.0397	0.0009
3816.0	0.0	0.0892	0.0232	-0.0007	-0.0494	-0.0410	-0.0018
3830.4	2.0	0.0907	0.0237	-0.0028	-0.0414	-0.0423	-0.0054

Run# 214

Dynamic Pressure (N/m ²)	Angle of Attack (deg)	D/q (m ²)	L/q (m ²)	SF/q (m ²)	PM/q (m ³)	YM/q (m ³)	RM/q (m ³)
1920.0	0.0	0.0785	0.0181	0.0123	-0.0423	-0.0353	-0.0095
2872.8	0.0	0.0822	0.0203	0.0133	-0.0473	-0.0374	-0.0076
3816.0	-8.0	0.0847	0.0120	0.0100	-0.0755	-0.0388	0.0012
3840.0	-6.0	0.0840	0.0136	0.0097	-0.0685	-0.0379	0.0024
3849.6	-4.0	0.0839	0.0148	0.0102	-0.0604	-0.0360	0.0008
3825.6	-2.0	0.0839	0.0179	0.0100	-0.0553	-0.0374	-0.0005
3816.0	0.0	0.0853	0.0197	0.0126	-0.0485	-0.0398	-0.0038
3825.6	2.0	0.0867	0.0206	0.0155	-0.0396	-0.0427	-0.0090

Run# 215

Dynamic Pressure (N/m ²)	Angle of Attack (deg)	D/q (m ²)	L/q (m ²)	SF/q (m ²)	PM/q (m ³)	YM/q (m ³)	RM/q (m ³)
1939.1	0.0	0.0746	0.0211	-0.0007	-0.0454	-0.0342	-0.0071
2863.2	0.0	0.0783	0.0249	-0.0061	-0.0510	-0.0376	-0.0054
3859.1	-8.0	0.0811	0.0078	0.0085	-0.0831	-0.0407	0.0061
3840.0	-6.0	0.0800	0.0092	0.0042	-0.0697	-0.0400	0.0030
3840.0	-4.0	0.0797	0.0139	-0.0014	-0.0633	-0.0389	0.0025
3835.2	-2.0	0.0798	0.0193	-0.0036	-0.0575	-0.0385	0.0010
3830.4	0.0	0.0815	0.0236	-0.0120	-0.0505	-0.0401	-0.0014
3830.4	2.0	0.0828	0.0267	-0.0144	-0.0418	-0.0395	-0.0050

Run# 216

Dynamic Pressure (N/m ²)	Angle of Attack (deg)	D/q (m ²)	L/q (m ²)	SF/q (m ²)	PM/q (m ³)	YM/q (m ³)	RM/q (m ³)
1915.2	0.0	0.0785	0.0321	0.0144	-0.0476	-0.0337	-0.0082
2872.8	0.0	0.0822	0.0322	0.0136	-0.0490	-0.0352	-0.0066
3801.7	-8.0	0.0833	0.0130	0.0150	-0.0751	-0.0367	0.0010
3801.7	-6.0	0.0830	0.0194	0.0129	-0.0702	-0.0354	0.0024
3816.0	-4.0	0.0835	0.0224	0.0120	-0.0615	-0.0353	0.0018
3825.6	-2.0	0.0841	0.0269	0.0129	-0.0554	-0.0354	-0.0002
3816.0	0.0	0.0847	0.0305	0.0136	-0.0485	-0.0390	-0.0028
3840.0	2.0	0.0866	0.0327	0.0182	-0.0392	-0.0443	-0.0065

Run# 217

Dynamic Pressure (N/m ²)	Angle of Attack (deg)	D/q (m ²)	L/q (m ²)	SF/q (m ²)	PM/q (m ³)	YM/q (m ³)	RM/q (m ³)
1910.4	0.0	0.0824	0.0200	0.0177	-0.0459	-0.0352	-0.0084
2872.8	0.0	0.0861	0.0203	0.0170	-0.0481	-0.0385	-0.0070
3835.2	-8.0	0.0875	0.0100	0.0172	-0.0733	-0.0381	0.0011
3820.8	-6.0	0.0868	0.0134	0.0173	-0.0684	-0.0369	0.0037
3835.2	-4.0	0.0873	0.0153	0.0177	-0.0613	-0.0382	0.0030
3835.2	-2.0	0.0872	0.0170	0.0174	-0.0540	-0.0380	0.0002
3816.0	0.0	0.0884	0.0189	0.0171	-0.0473	-0.0415	-0.0029
3816.0	2.0	0.0901	0.0203	0.0180	-0.0390	-0.0445	-0.0069

Run# 218

Dynamic Pressure (N/m ²)	Angle of Attack (deg)	D/q (m ²)	L/q (m ²)	SF/q (m ²)	PM/q (m ³)	YM/q (m ³)	RM/q (m ³)
1924.8	0.0	0.0809	0.0192	0.0194	-0.0441	-0.0376	-0.0094
2863.2	0.0	0.0833	0.0193	0.0199	-0.0461	-0.0391	-0.0081
3806.5	-8.0	0.0858	0.0097	0.0133	-0.0732	-0.0387	0.0019
3818.0	-6.0	0.0852	0.0138	0.0150	-0.0694	-0.0382	0.0043
3801.7	-4.0	0.0855	0.0152	0.0174	-0.0611	-0.0371	0.0024
3806.5	-2.0	0.0859	0.0169	0.0179	-0.0542	-0.0389	0.0008
3816.0	0.0	0.0871	0.0188	0.0198	-0.0465	-0.0421	-0.0026
3806.5	2.0	0.0887	0.0197	0.0214	-0.0390	-0.0450	-0.0079

Run# 219

Dynamic Pressure (N/m ²)	Angle of Attack (deg)	D/q (m ²)	L/q (m ²)	SF/q (m ²)	PM/q (m ³)	YM/q (m ³)	RM/q (m ³)
1915.2	0.0	0.0750	0.0279	0.0200	-0.0434	-0.0352	-0.0096
2853.6	0.0	0.0786	0.0291	0.0198	-0.0474	-0.0377	-0.0084
3806.5	-8.0	0.0807	0.0100	0.0146	-0.0746	-0.0361	0.0020
3811.2	-6.0	0.0804	0.0163	0.0173	-0.0686	-0.0351	0.0032
3811.2	-4.0	0.0805	0.0201	0.0163	-0.0615	-0.0356	0.0022
3811.2	-2.0	0.0806	0.0242	0.0169	-0.0548	-0.0377	0.0010
3820.8	0.0	0.0817	0.0274	0.0185	-0.0471	-0.0393	-0.0038
3801.7	2.0	0.0839	0.0298	0.0200	-0.0379	-0.0435	-0.0067

Run# 220

Dynamic Pressure (N/m ²)	Angle of Attack (deg)	D/q (m ²)	L/q (m ²)	SF/q (m ²)	PM/q (m ³)	YM/q (m ³)	RM/q (m ³)
1905.6	0.0	0.0726	0.0247	0.0124	-0.0443	-0.0371	-0.0081
3859.1	-8.0	0.0786	0.0093	0.0139	-0.0758	-0.0403	0.0032
3840.0	-6.0	0.0778	0.0140	0.0144	-0.0695	-0.0399	0.0055
3840.0	-4.0	0.0770	0.0171	0.0163	-0.0608	-0.0380	0.0041
3844.8	-2.0	0.0780	0.0209	0.0130	-0.0541	-0.0398	0.0022
3816.0	0.0	0.0793	0.0245	0.0131	-0.0461	-0.0423	-0.0009
3830.4	2.0	0.0807	0.0271	0.0134	-0.0386	-0.0436	-0.0052

Run# 221

Dynamic Pressure (N/m ²)	Angle of Attack (deg)	D/q (m ²)	L/q (m ²)	SF/q (m ²)	PM/q (m ³)	YM/q (m ³)	RM/q (m ³)
1910.4	0.0	0.0785	0.0165	0.0140	-0.0408	-0.0358	-0.0100
2858.4	0.0	0.0820	0.0193	0.0142	-0.0463	-0.0392	-0.0082
3820.8	-8.0	0.0842	0.0108	0.0128	-0.0744	-0.0396	0.0021
3820.8	-6.0	0.0836	0.0134	0.0127	-0.0682	-0.0375	0.0040
3820.8	-4.0	0.0836	0.0142	0.0127	-0.0601	-0.0383	0.0031
3825.6	-2.0	0.0837	0.0163	0.0126	-0.0528	-0.0384	0.0011
3806.5	0.0	0.0851	0.0178	0.0141	-0.0457	-0.0410	-0.0022
3801.7	2.0	0.0868	0.0195	0.0167	-0.0386	-0.0445	-0.0065

Run# 222

Dynamic Pressure (N/m ²)	Angle of Attack (deg)	D/q (m ²)	L/q (m ²)	SF/q (m ²)	PM/q (m ³)	YM/q (m ³)	RM/q (m ³)
1934.4	0.0	0.0784	0.0177	0.0122	-0.0411	-0.0350	-0.0078
2877.6	0.0	0.0824	0.0204	0.0127	-0.0463	-0.0386	-0.0064
3835.2	-8.0	0.0855	0.0137	0.0116	-0.0798	-0.0390	0.0061
3825.6	-6.0	0.0845	0.0164	0.0119	-0.0738	-0.0381	0.0080
3844.8	-4.0	0.0846	0.0176	0.0109	-0.0662	-0.0375	0.0061
3844.8	-2.0	0.0842	0.0172	0.0116	-0.0532	-0.0375	0.0004
3830.4	0.0	0.0856	0.0193	0.0129	-0.0460	-0.0410	-0.0022
3811.2	2.0	0.0868	0.0203	0.0148	-0.0384	-0.0440	-0.0067

Run# 223

Dynamic Pressure (N/m ²)	Angle of Attack (deg)	D/q (m ²)	L/q (m ²)	SF/q (m ²)	PM/q (m ³)	YM/q (m ³)	RM/q (m ³)
1924.8	0.0	0.0712	0.0220	0.0150	-0.0417	-0.0345	-0.0078
2896.7	0.0	0.0752	0.0238	0.0138	-0.0459	-0.0391	-0.0059
3844.8	-8.0	0.0782	0.0096	0.0135	-0.0808	-0.0389	0.0055
3859.1	-6.0	0.0775	0.0122	0.0134	-0.0688	-0.0384	0.0036
3859.1	-4.0	0.0769	0.0152	0.0124	-0.0607	-0.0372	0.0024
3844.8	-2.0	0.0773	0.0194	0.0124	-0.0541	-0.0383	0.0010
3835.2	0.0	0.0782	0.0226	0.0157	-0.0453	-0.0406	-0.0028
3835.2	2.0	0.0796	0.0244	0.0148	-0.0363	-0.0432	-0.0072

Run# 224

Dynamic Pressure (N/m ²)	Angle of Attack (deg)	D/q (m ²)	L/q (m ²)	SF/q (m ²)	PM/q (m ³)	YM/q (m ³)	RM/q (m ³)
1939.1	0.0	0.0718	0.0202	0.0133	-0.0436	-0.0350	-0.0085
2892.0	0.0	0.0757	0.0211	0.0132	-0.0466	-0.0385	-0.0070
3854.3	-8.0	0.0788	0.0047	0.0120	-0.0750	-0.0403	0.0032
3854.3	-6.0	0.0774	0.0092	0.0126	-0.0681	-0.0377	0.0037
3859.1	-4.0	0.0773	0.0129	0.0120	-0.0612	-0.0372	0.0030
3830.4	-2.0	0.0776	0.0161	0.0135	-0.0531	-0.0380	0.0005
3854.3	0.0	0.0789	0.0202	0.0199	-0.0465	-0.0402	-0.0037
3844.8	2.0	0.0811	0.0236	0.0241	-0.0394	-0.0443	-0.0084

Run# 225

Dynamic Pressure (N/m ²)	Angle of Attack (deg)	D/q (m ²)	L/q (m ²)	SF/q (m ²)	PM/q (m ³)	YM/q (m ³)	RM/q (m ³)
1939.1	0.0	0.0780	0.0179	0.0142	-0.0428	-0.0353	-0.0081
2848.9	0.0	0.0815	0.0187	0.0150	-0.0450	-0.0393	-0.0074
3830.4	-8.0	0.0847	0.0108	0.0136	-0.0731	-0.0385	0.0015
3835.2	-6.0	0.0839	0.0129	0.0136	-0.0664	-0.0379	0.0026
3835.2	-4.0	0.0836	0.0147	0.0125	-0.0597	-0.0377	0.0015
3835.2	-2.0	0.0839	0.0166	0.0132	-0.0527	-0.0381	0.0005
3835.2	0.0	0.0847	0.0181	0.0154	-0.0457	-0.0409	-0.0031
3830.4	2.0	0.0862	0.0196	0.0175	-0.0372	-0.0434	-0.0081

Run# 226

Dynamic Pressure (N/m ²)	Angle of Attack (deg)	D/q (m ²)	L/q (m ²)	SF/q (m ²)	PM/q (m ³)	YM/q (m ³)	RM/q (m ³)
1934.4	0.0	0.0816	0.0205	0.0131	-0.0426	-0.0352	-0.0081
2906.3	0.0	0.0846	0.0211	0.0153	-0.0450	-0.0381	-0.0083
3816.0	-8.0	0.0866	0.0138	0.0127	-0.0757	-0.0394	0.0014
3825.6	-6.0	0.0859	0.0157	0.0115	-0.0686	-0.0376	0.0029
3816.0	-4.0	0.0860	0.0171	0.0131	-0.0609	-0.0372	0.0019
3796.9	-2.0	0.0861	0.0190	0.0131	-0.0534	-0.0373	0.0003
3816.0	0.0	0.0877	0.0212	0.0160	-0.0462	-0.0399	-0.0034
3816.0	2.0	0.0887	0.0227	0.0176	-0.0386	-0.0435	-0.0082

Run# 227

Dynamic Pressure (N/m ²)	Angle of Attack (deg)	D/q (m ²)	L/q (m ²)	SF/q (m ²)	PM/q (m ³)	YM/q (m ³)	RM/q (m ³)
1939.1	0.0	0.0707	0.0225	0.0170	-0.0432	-0.0353	-0.0071
2896.7	0.0	0.0742	0.0227	0.0184	-0.0457	-0.0383	-0.0074
3830.4	-8.0	0.0775	0.0084	0.0142	-0.0811	-0.0377	0.0057
3844.8	-6.0	0.0766	0.0105	0.0147	-0.0673	-0.0378	0.0026
3835.2	-4.0	0.0760	0.0146	0.0140	-0.0615	-0.0364	0.0020
3830.4	-2.0	0.0761	0.0193	0.0158	-0.0547	-0.0381	0.0000
3811.2	0.0	0.0770	0.0221	0.0203	-0.0461	-0.0401	-0.0037
3796.9	2.0	0.0783	0.0258	0.0206	-0.0395	-0.0432	-0.0078

Run# 228

Dynamic Pressure (N/m ²)	Angle of Attack (deg)	D/q (m ²)	L/q (m ²)	SF/q (m ²)	PM/q (m ³)	YM/q (m ³)	RM/q (m ³)
1939.1	0.0	0.0743	0.0259	0.0115	-0.0444	-0.0351	-0.0082
2892.0	0.0	0.0778	0.0226	0.0140	-0.0440	-0.0374	-0.0087
3835.2	-8.0	0.0820	0.0066	0.0109	-0.0746	-0.0387	0.0009
3840.0	-6.0	0.0803	0.0101	0.0123	-0.0674	-0.0388	0.0022
3849.6	-4.0	0.0798	0.0142	0.0121	-0.0606	-0.0369	0.0012

Run# 229

Dynamic Pressure (N/m ²)	Angle of Attack (deg)	D/q (m ²)	L/q (m ²)	SF/q (m ²)	PM/q (m ³)	YM/q (m ³)	RM/q (m ³)
1915.2	0.0	0.0664	0.0105	0.0130	-0.0467	-0.0365	-0.0077
2863.2	0.0	0.0696	0.0089	0.0123	-0.0457	-0.0383	-0.0077
3825.6	-8.0	0.0733	0.0050	0.0128	-0.0768	-0.0378	-0.0031
3825.6	-6.0	0.0726	0.0059	0.0114	-0.0691	-0.0384	-0.0005
3820.8	-4.0	0.0723	0.0071	0.0108	-0.0617	-0.0377	-0.0002
3825.6	-2.0	0.0717	0.0085	0.0115	-0.0551	-0.0382	-0.0008
3801.7	0.0	0.0728	0.0082	0.0136	-0.0454	-0.0409	-0.0049
3796.9	2.0	0.0743	0.0077	0.0162	-0.0365	-0.0432	-0.0085

Run# 232

Dynamic Pressure (N/m ²)	Angle of Attack (deg)	D/q (m ²)	L/q (m ²)	SF/q (m ²)	PM/q (m ³)	YM/q (m ³)	RM/q (m ³)
1943.9	-3.0	0.0469	0.0041	0.0071	-0.0187	0.0003	-0.0504
1943.9	-3.0	0.0469	0.0041	0.0076	-0.0182	-0.0001	-0.0512
1943.9	-2.0	0.0469	0.0092	0.0071	-0.0216	-0.0069	-0.0366
1948.7	-2.0	0.0470	0.0107	0.0066	-0.0227	-0.0068	-0.0358
1943.9	-1.0	0.0462	0.0201	0.0066	-0.0291	-0.0157	-0.0177
1943.9	-1.0	0.0462	0.0192	0.0069	-0.0282	-0.0155	-0.0179
1948.7	0.0	0.0441	0.0338	0.0062	-0.0370	-0.0234	0.0026
1943.9	0.0	0.0439	0.0341	0.0066	-0.0373	-0.0235	0.0028

Run# 234

Dynamic Pressure (N/m ²)	Angle of Attack (deg)	D/q (m ²)	L/q (m ²)	SF/q (m ²)	PM/q (m ³)	YM/q (m ³)	RM/q (m ³)
1929.6	-3.0	0.0461	0.0113	0.0069	-0.0223	-0.0004	-0.0445
1920.0	-3.0	0.0463	0.0107	0.0067	-0.0217	-0.0002	-0.0448
1924.8	-3.0	0.0462	0.0111	0.0067	-0.0217	-0.0002	-0.0448
1929.6	-2.0	0.0466	0.0168	0.0067	-0.0262	-0.0078	-0.0298
1924.8	-2.0	0.0469	0.0171	0.0067	-0.0261	-0.0082	-0.0302
1929.6	-1.0	0.0459	0.0284	0.0065	-0.0336	-0.0165	-0.0093
1929.6	-1.0	0.0461	0.0272	0.0067	-0.0331	-0.0171	-0.0096
1924.8	-1.0	0.0462	0.0270	0.0060	-0.0325	-0.0164	-0.0101
1920.0	0.0	0.0443	0.0431	0.0058	-0.0435	-0.0250	0.0131
1920.0	0.0	0.0440	0.0422	0.0058	-0.0426	-0.0246	0.0123
1929.6	0.0	0.0445	0.0420	0.0060	-0.0426	-0.0254	0.0122

Run# 235

Dynamic Pressure (N/m ²)	Angle of Attack (deg)	D/q (m ²)	L/q (m ²)	SF/q (m ²)	PM/q (m ³)	YM/q (m ³)	RM/q (m ³)
1929.6	-3.0	0.0422	-0.0115	0.0076	-0.0046	0.0018	-0.0544
1920.0	-3.0	0.0422	-0.0116	0.0074	-0.0041	0.0024	-0.0542
1929.6	-3.0	0.0424	-0.0115	0.0078	-0.0042	0.0016	-0.0544
1924.8	-2.0	0.0425	-0.0065	0.0079	-0.0089	-0.0072	-0.0364
1924.8	-2.0	0.0423	-0.0072	0.0079	-0.0082	-0.0073	-0.0372
1924.8	-2.0	0.0423	-0.0062	0.0079	-0.0095	-0.0073	-0.0364
1915.2	-1.0	0.0437	0.0000	0.0084	-0.0148	-0.0178	-0.0173
1920.0	-1.0	0.0433	0.0007	0.0081	-0.0154	-0.0171	-0.0164
1924.8	-1.0	0.0437	-0.0007	0.0074	-0.0142	-0.0168	-0.0177
1915.2	0.0	0.0432	0.0086	0.0077	-0.0208	-0.0257	0.0013
1915.2	0.0	0.0432	0.0093	0.0079	-0.0215	-0.0259	0.0013
1920.0	0.0	0.0429	0.0079	0.0079	-0.0211	-0.0258	0.0013
1929.6	1.0	0.0408	0.0258	0.0062	-0.0331	-0.0324	0.0229
1920.0	1.0	0.0405	0.0269	0.0065	-0.0340	-0.0324	0.0237
1924.8	1.0	0.0407	0.0266	0.0069	-0.0342	-0.0332	0.0231

ORIGINAL PAGE IS
OF POOR QUALITY

Run# 236

Dynamic Pressure (N/m ²)	Angle of Attack (deg)	D/q (m ²)	L/q (m ²)	SF/q (m ²)	PM/q (m ³)	YM/q (m ³)	RM/q (m ³)
1915.2	-3.0	0.0446	-0.0056	0.0070	-0.0118	0.0027	-0.0502
1910.4	-3.0	0.0452	-0.0065	0.0061	-0.0115	0.0036	-0.0502
1915.2	-3.0	0.0446	-0.0056	0.0065	-0.0118	0.0031	-0.0508
1910.4	-2.0	0.0452	0.0023	0.0072	-0.0172	-0.0072	-0.0343
1915.2	-2.0	0.0451	0.0012	0.0074	-0.0161	-0.0074	-0.0351
1910.4	-2.0	0.0449	0.0009	0.0072	-0.0158	-0.0068	-0.0352
1915.2	-1.0	0.0453	0.0111	0.0077	-0.0220	-0.0174	-0.0152
1910.4	-1.0	0.0456	0.0095	0.0077	-0.0210	-0.0174	-0.0155
1910.4	-1.0	0.0452	0.0109	0.0070	-0.0221	-0.0159	-0.0140
1910.4	0.0	0.0426	0.0261	0.0063	-0.0305	-0.0237	0.0055
1920.0	0.0	0.0428	0.0250	0.0065	-0.0300	-0.0241	0.0052
1910.4	0.0	0.0431	0.0251	0.0068	-0.0302	-0.0245	0.0055

Run# 237

Dynamic Pressure (N/m ²)	Angle of Attack (deg)	D/q (m ²)	L/q (m ²)	SF/q (m ²)	PM/q (m ³)	YM/q (m ³)	RM/q (m ³)
1939.1	-3.0	0.0431	-0.0007	0.0064	-0.0147	0.0034	-0.0509
1934.4	-3.0	0.0432	-0.0018	0.0060	-0.0149	0.0043	-0.0504
1943.9	-3.0	0.0428	0.0005	0.0062	-0.0156	0.0040	-0.0499
1939.1	-2.0	0.0434	0.0083	0.0062	-0.0218	-0.0060	-0.0320
1924.8	-2.0	0.0432	0.0081	0.0065	-0.0212	-0.0055	-0.0323
1939.1	-2.0	0.0436	0.0108	0.0067	-0.0234	-0.0064	-0.0297
1939.1	-1.0	0.0434	0.0186	0.0057	-0.0283	-0.0139	-0.0117
1943.9	-1.0	0.0435	0.0188	0.0057	-0.0281	-0.0143	-0.0113
1934.4	-1.0	0.0437	0.0177	0.0062	-0.0276	-0.0148	-0.0127
1934.4	0.0	0.0421	0.0313	0.0053	-0.0361	-0.0217	0.0084
1934.4	0.0	0.0421	0.0301	0.0055	-0.0350	-0.0215	0.0059
1939.1	0.0	0.0417	0.0305	0.0050	-0.0357	-0.0211	0.0064

Run# 238

Dynamic Pressure (N/m ²)	Angle of Attack (deg)	D/q (m ²)	L/q (m ²)	SF/q (m ²)	PM/q (m ³)	YM/q (m ³)	RM/q (m ³)
1934.4	-3.0	0.0437	-0.0092	0.0062	-0.0085	0.0041	-0.0525
1938.1	-3.0	0.0436	-0.0096	0.0060	-0.0080	0.0047	-0.0530
1939.1	-3.0	0.0436	-0.103	0.0062	-0.0078	0.0041	-0.0535
1934.4	-2.0	0.0442	-0.048	0.0069	-0.0122	-0.0066	-0.0343
1929.6	-2.0	0.0440	-0.046	0.0074	-0.0124	-0.0070	-0.0345
1920.0	-2.0	0.0438	-0.049	0.0072	-0.0125	-0.0065	-0.0343
1934.4	-1.0	0.0455	0.0018	0.0076	-0.0184	-0.0187	-0.0163
1924.8	-1.0	0.0453	0.0016	0.0067	-0.0186	-0.0156	-0.0161
1929.6	-1.0	0.0450	0.0012	0.0074	-0.0176	-0.0162	-0.0170
1929.6	0.0	0.0431	0.0113	0.0071	-0.0246	-0.0238	0.0025
1934.4	0.0	0.0428	0.0113	0.0069	-0.0244	-0.0231	0.0015
1939.1	1.0	0.0422	0.0275	0.0057	-0.0365	-0.0313	0.0232
1939.1	1.0	0.0420	0.0275	0.0055	-0.0364	-0.0311	0.0233
1943.9	1.0	0.0419	0.0270	0.0059	-0.0359	-0.0318	0.0226

Run# 239

Dynamic Pressure (N/m ²)	Angle of Attack (deg)	D/q (m ²)	L/q (m ²)	SF/q (m ²)	PM/q (m ³)	YM/q (m ³)	RM/q (m ³)
1920.0	-3.0	0.0426	-0.0002	0.0070	-0.0146	0.0025	-0.0491
1934.4	-3.0	0.0430	0.0007	0.0064	-0.0151	0.0026	-0.0484
1929.6	-3.0	0.0429	0.0005	0.0067	-0.0148	0.0019	-0.0487
1929.6	-2.0	0.0431	0.0065	0.0074	-0.0196	-0.0079	-0.0303
1920.0	-2.0	0.0431	0.0072	0.0070	-0.0203	-0.0080	-0.0299
1920.0	-1.0	0.0443	0.0151	0.0072	-0.0253	-0.0174	-0.0124
1929.6	-1.0	0.0440	0.0157	0.0071	-0.0258	-0.0173	-0.0112
1924.8	-1.0	0.0441	0.0159	0.0067	-0.0261	-0.0165	-0.0111
1915.2	0.0	0.0420	0.0290	0.0067	-0.0347	-0.0249	0.0075
1924.8	0.0	0.0423	0.0293	0.0067	-0.0347	-0.0251	0.0071

ORIGINAL PAGE IS
OF POOR QUALITY

Run# 240

Dynamic Pressure (N/m ²)	Angle of Attack (deg)	D/q (m ²)	L/q (m ²)	SF/q (m ²)	PM/q (m ³)	YM/q (m ³)	RM/q (m ³)
1915.2	-3.0	0.0418	-0.0044	0.0063	-0.0121	0.0039	-0.0534
1905.6	-3.0	0.0418	-0.0042	0.0072	-0.0118	0.0026	-0.0514
1915.2	-3.0	0.0413	-0.0044	0.0070	-0.0111	0.0032	-0.0519
1900.8	-2.0	0.0426	0.0007	0.0073	-0.0161	-0.0067	-0.0350
1900.8	-2.0	0.0426	0.0019	0.0075	-0.0172	-0.0069	-0.0342
1900.8	-1.0	0.0438	0.0077	0.0080	-0.0217	-0.0175	-0.0155
1896.0	-1.0	0.0436	0.0084	0.0075	-0.0219	-0.0167	-0.0150
1905.6	-1.0	0.0437	0.0070	0.0079	-0.0209	-0.0174	-0.0152
1891.3	0.0	0.0421	0.0183	0.0068	-0.0282	0.0238	0.0044
1900.8	0.0	0.0421	0.0187	0.0070	-0.0286	-0.0249	0.0039
1900.8	0.0	0.0421	0.0187	0.0075	-0.0286	-0.0250	0.0034
1905.6	1.0	0.0406	0.0222	0.0044	-0.0309	-0.0304	0.0233
1905.6	1.0	0.0411	0.0212	0.0042	-0.0298	-0.0309	0.0215
1896.0	1.0	0.0404	0.0218	0.0042	-0.0300	-0.0303	0.0224

Run# 241

Dynamic Pressure (N/m ²)	Angle of Attack (deg)	D/q (m ²)	L/q (m ²)	SF/q (m ²)	PM/q (m ³)	YM/q (m ³)	RM/q (m ³)
1886.5	-3.0	0.0408	-0.0075	0.0073	-0.0063	0.0025	-0.0538
1886.5	-3.0	0.0408	-0.0078	0.0073	-0.0060	0.0025	-0.0542
1886.5	-3.0	0.0410	-0.0075	0.0073	-0.0063	0.0025	-0.0535
1896.0	-2.0	0.0411	-0.0047	0.0084	-0.0097	-0.0076	-0.0362
1905.6	-2.0	0.0413	-0.0040	0.0082	-0.0105	-0.0077	-0.0362
1905.6	-2.0	0.0413	-0.0047	0.0079	-0.0094	-0.0071	-0.0373
1896.0	-1.0	0.0425	0.0077	0.0077	-0.0147	-0.0170	-0.0164
1900.8	-1.0	0.0426	-0.0007	0.0080	-0.0134	-0.0176	-0.0177
1900.8	0.0	0.0419	0.0068	0.0080	-0.0191	0.0262	0.0017
1891.3	0.0	0.0416	0.0073	0.0078	-0.0195	-0.0262	0.0015
1891.3	0.0	0.0414	0.0066	0.0075	-0.0187	-0.0256	0.0015
1896.0	1.0	0.0392	0.0242	0.0068	-0.0318	-0.0333	0.0228
1910.4	1.0	0.0391	0.0240	0.0065	-0.0316	-0.0328	0.0228
1910.4	1.0	0.0387	0.0231	0.0063	-0.0310	-0.0322	0.0227

Run# 242

Dynamic Pressure (N/m ²)	Angle of Attack (deg)	D/q (m ²)	L/q (m ²)	SF/q (m ²)	PM/q (m ³)	YM/q (m ³)	RM/q (m ³)
1948.7	0.0	0.0429	-0.0066	0.0046	-0.0120	-0.0232	-0.0007
1943.9	0.0	0.0430	-0.0080	0.0041	-0.0108	-0.0232	-0.0018
1910.4	-2.0	0.0419	-0.0051	0.0084	-0.0113	-0.0078	-0.0374
1905.6	-2.0	0.0420	-0.0044	0.0077	-0.0120	-0.0072	-0.0364
1896.0	-2.0	0.0420	-0.0049	0.0077	-0.0115	-0.0072	-0.0370
1896.0	-1.0	0.0427	-0.0009	0.0080	-0.0153	-0.0172	-0.0185
1900.8	-1.0	0.0428	-0.0012	0.0082	-0.0156	-0.0178	-0.0186
1905.6	-1.0	0.0430	-0.0009	0.0082	-0.0158	-0.0177	-0.0178
1891.3	0.0	0.0433	0.0049	0.0082	-0.0204	-0.0265	-0.0008
1900.8	0.0	0.0433	0.0054	0.0080	-0.0204	-0.0265	-0.0003
1900.8	0.0	0.0431	0.0059	0.0077	-0.0208	-0.0263	-0.0001
1905.6	1.0	0.0397	0.0215	0.0068	-0.0321	-0.0326	0.0206
1900.8	1.0	0.0393	0.0199	0.0070	-0.0305	-0.0330	0.0204
1910.4	1.0	0.0398	0.0200	0.0075	-0.0308	-0.0336	0.0198

APPENDIX B

FAIRING CONTOUR EQUATIONS

Pylon Cross Sections

Thickness distribution— NACA four-digit airfoil equations were used as the base to generate the pylon cross sections. Geometric conditions were specified to define the coefficients in the thickness distribution equation.

The general form of the thickness distribution equation for the four-digit series airfoils is (ref. 9):

$$y_t = t/c(a_0x_p + a_1x_p + a_2x_p^2 + a_3x_p^3 + a_4x_p^4)$$

or

$$y_t = Ax_p + Bx_p + Cx_p^2 + Dx_p^3 + Ex_p^4$$

where

- y_t = total sectional thickness (fraction of chord)
- t = maximum thickness (m)
- c = chord length (m)
- x_p = chordwise coordinate (fraction of chord)

Note that in this report y_t and t represents the total sectional thickness and total maximum thickness, and are different from the notations used in reference 9.

Thus it would take five geometric conditions to uniquely determine the coefficients A, B, C, D and E. The conditions are:

- 1) Maximum thickness location, l ; i.e., $y_t = t$ at $x = l$;
- 2) Zero surface curvature at maximum thickness location; i.e., $dy_t/dx = 0$ at $x = l$;
- 3) Trailing edge slope; i.e., $dy_t/dx = s$ at $x = 1$.
- 4) Zero thickness at the trailing edge; i.e., $y_t = 0$ at $x = 1$.
- 5) Leading edge radius, r_L ; where $r_L = A^2/2$.

The coefficient A was assigned a value of 1.485 which would yield the leading edge radius of the NACA 0034 airfoil ($r_L = 0.1275c$). A maximum thickness ratio of 34% ($t = 0.34$) was chosen also to narrow down the scope of the investigation. Therefore, the two parameters, l and s , were the focal points of the parametric study (section 6.1.1) and varied independently to generate new shapes. Once the parameters l and s were selected, the coefficients B, C, D, and E could be solved numerically.

Pylon camber— The mean line equations for the NACA four-digit series airfoils (ref. 9) were used to generate the cross section of the cambered pylon. The equations are:

PRECEDING PAGE BLANK NOT FILMED

$$y_c = \frac{m_p}{p^2} (2px_p - x_p^2) \quad \text{forward of maximum ordinate}$$

$$y_c = \frac{m_p}{(1-p)^2} \{(1-2p) + 2px_p - x_p^2\} \quad \text{aft of maximum ordinate}$$

where

y_c = ordinate of the mean line (fraction of chord)

p = chordwise position of maximum ordinate (fraction of chord)

m_p = pylon fairing camber (fraction of chord)

Geometric descriptions of all pylons tested are given in appendix C.

Hub Fairing Contour Equations

Three specific cross-sections are good candidates for the hub fairings: elliptical arc, circular arc, and reflexed arc. The equations of these cross sections are given below.

Elliptical Arc: $y = t_0(1 - x_h^2)^{1/2}$

Circular Arc: $y = [\{ (1 + t_0^2)/2t_0 \}^2 - x_0^2]^{1/2} + t_0 - \{ (1 + t_0^2)/2t_0 \}$

Reflexed Arc: $y = t_0 + \frac{3(r_0 - t_0)}{(1 - r_0)^2} x_h^2 - \frac{2(r_0 - t_0)}{(1 - r_0)^3} x_h^3$

where

x_h = nondimensional radial coordinate (normalized by radius)

t_0 = hub fairing thickness ratio, t/d

t = hub fairing thickness (m)

d = hub fairing diameter (m)

r_0 = nondimensional rim thickness, is defined as $0.0127m/t$

A new parameter, rim thickness (r_0), was introduced. Two conditions based on rim thickness were: at $x = 1 - r_0$, $y = r_0$, and $dy/dx = 0$. Geometric descriptions of all hub fairings tested are given in appendix C.

APPENDIX C
SHAFT FAIRING DESIGNATION

Number	Parameters					Description
	l	s	m	p	t/c	
S10	0.30	-4.00			0.34	Trailing edge slope sweep
S20	0.30	-3.00			0.34	Trailing edge slope sweep
S30	0.30	-2.00			0.34	Trailing edge slope sweep
S40	0.30	-1.17			0.34	Baseline shaft fairing
S50	0.55	-1.17			0.34	Max. thickness loc. sweep
S60	0.50	-1.17			0.34	Max. thickness loc. sweep
S70	0.40	-1.17			0.34	Max. thickness loc. sweep
S80	0.20	-1.17			0.34	Max. thickness loc. sweep
S100	0.45	-1.17			0.34	Max. thickness loc. sweep
S110	0.25	-1.17			0.34	Max. thickness loc. sweep
S120	0.30	-1.17	0.02	0.40	0.34	Camber sweep
S130	0.30	-1.17	0.04	0.40	0.34	Camber sweep
S140	0.30	-1.17			0.28	Thickness ratio sweep
S150	0.30	-1.17			0.24	Thickness ratio sweep
S200	0.50				0.43	Matching contour s/f

- l = Location of maximum thickness (fraction of chord length)
- s = Trailing edge slope
- m = Camber (fraction of chord length)
- p = Chordwise location of maximum camber (fraction of chord length)
- t/c = Thickness ratio

APPENDIX D

TEST LOG LEGEND AND TEST LOG

BS1 = Blade Shank Incorporation (set #1)
BS2 = Blade Shank Incorporation (set #2)
BS2/IS = Blade Shank Incorporation (set #2) with Inclined Shaft

C = Coaxial
CF = Clean Fuselage

D = Data Run

FL = Flow Visualization Run - Laser Sheet
FO = Flow Visualization Run - Oil
FT = Flow Visualization Run - Tufts

G/H = Gap Width/Hub Fairing Height
GR = Hub and Shaft Fairing Gap - Remedies
GW = Gap Width

HC-1 = Hub Fairing Camber (t = .18)
HC-2 = Hub Fairing Camber (t = .24)
HCC = Hub Fairing Cambered Surface Contour
HD1-1 = Cambered Elliptical Hub Fairing from Hub Drag I Test
HD1-2 = Elliptical Hub Fairing from Hub Drag I Test
HH = Minimum Hub Fairing Height
HSC = Hub Fairing Symmetrical Surface Contour
HT-D = Hub Fairing Thickness Ratio (constant diameter)
HT-T = Hub Fairing Thickness Ratio (constant thickness)

IHF = Isolated Hub Fairing
IS = Inclined Shaft

LE = Leading Edge

MC = Matching Contour

SC = Shaft Fairing Camber
SE = Shaft Fairing Leading Edge and Trailing Edge Extensions
SF = Shaft Fairing
SFT = Shaft Fairing Tare
SL = Shaft Fairing Location of Maximum Thickness
SS = Shaft Fairing Trailing Edge Slope
ST = Shaft Fairing Thickness Ratio

TE = Trailing Edge

US = Unfaired Shaft

PRECEDING PAGE BLANK NOT FILMED

Run #	Run Type	Dynamic Pressure (Pa)	Hub Fairing	Shaft Fairing	Sweep Type	Notes
7A	FT	3830			CF	
7B	FT	3830	H50	10	SS	
7C	FT	3830	H10	S10	SS	
8	D	1915-3830	H10	S10	SS	
9	D	1915-3830	H50	S10	SS	
10	D	1915-3830			CF	
10A	FT	3830	H50	S80	SL, HC-1	
11	D	1915-3830	H50	S80	SL, HC-1	
11A	FT	3830	H10	S80	SL	
13	D	1915-3830	H10	S80	SL	
14	D	1915-3830	HD1-1			
14A	FT	3830	H50	S40	Many	
14B	FT	3830	H10	S40	Many	
15	D	1915-3830	H10	S40	Many	
16	D	1915-3830	H50	S40	Many	
16A	FT	3830	H50	S60	SL	
16B	FT	3830	H10	S60	SL	
17	D	1915-3830	H10	S60	SL	
18	D	1915-3830	H50	S60	SL	
18A	FT	3830	H50	S30	SS	
18B	FT	3830	H10	S30	SS	
19	D	1915-3830	H10	S30	SS	
20	D	1915-3830	H50	S30	SS	
20A	FT	3830	H10	S20	SS	
20B	FT	3830	H50	S20	SS	
21	D	1915-3830	H50	S20	SS	

Run #	Run Type	Dynamic Pressure (Pa)	Hub Fairing	Shaft Fairing	Sweep Type	Notes
22	D	1915-3830	H10	S20	SS	
22A	FT	3830	H50	S50	SL	
22B	FT	3830	H10	S50	SL	
23	D	1915-3830	H10	S50	SL	
24	D	1915-3830	H50	S50	SL	
24A	FT	3830	H50	S70	SL	
24B	FT	3830	H10	S70	SL	
26	D	1915-3830	H50	S70	SL	
27	D	1915-3830	H10	S70	SL	
27A	FT	3830	H50	S100	SL	
27B	FT	3830	H10	S100	SL	
28	D	1915-3830	H10	S100	SL	
29	D	1915-3830	H50	S100	SL	
29A	FT	3830	H10	S110	SL	
29B	FT	3830	H50	S110	SL	
30	D	1915-3830	H50	S110	SL	
31	D	1915-3830	H10	S110	SL	
31A	FT	3830	H50	S140	ST	
31B	FT	3830	H10	S140	ST	
32	D	1915-3830	H10	S140	ST	
33	D	1915-3830	H50	S140	ST	
34	D	3830	H50	S140	ST	
35	D	3830	H50	S140	ST	
36	D	1915-3830	N/A	N/A	CF	
37	D	1915-3830	N/A	N/A	CF	
38	D	1915-3830	H50	S140	ST	
39	D	1915-3830	H50	S140	ST	

Run #	Run Type	Dynamic Pressure (Pa)	Hub Fairing	Shaft Fairing	Sweep Type	Notes
40	D	1915-3830	H50	S140	ST	
41	D	1915-3830	H50	S140	ST	
41A	FT	3830	H10	S150	ST	
41B	FT	3830	H50	S150	ST	
41C	FT	3830	H50	S150	ST	
42	D	1915-3830	H50	S150	ST	
43	D	1915-3830	H10	S150	ST	
44	D	1915-3830	H10	S40	Many	
44A	FT	3830	H10	S40	Many	
44B	FT	3830	H20	S40	HC-1	
44C	FT	3830	H30	S40	HC-1	
44D	FT	3830	H40	S40	HC-1	
44E	FT	3830	H50	S40	Many	
44F	FT	3830	H60	S40	HC-1	
45	D	1915-3830	H60	S40	HC-1	
46	D	1915-3830	H20	S40	HC-1	
47	D	1915-3830	H30	S40	HC-1	
49	D	3830	H40	S40	HC-1	
50	D	1915-3830	H40	S40	HC-1	
51	D	1915-3830	H50	S40	Many	
51A	FT	3830	H80	S40	HC-2	
51B	FT	3830	H90	S40	HC-2	
53	D	1915-3830	H90	S40	HC-2	
54	D	1915-3830	H80	S40	HC-2	
54A	FT	3830	H20	S80	HC-1	
54B	FT	3830	H30	S80	HC-1	
54C	FT	3830	H40	S80	HC-1	
54D	FT	3830	H50	S80	HC-1, SL	
54E	FT	3830	H60	S80	HC-1	
54F	FT	3830	H10	S80	SL	
55	D	1915-3830	H10	S80	SL	

Run #	Run Type	Dynamic Pressure (Pa)	Hub Fairing	Shaft Fairing	Sweep Type	Notes
56	D	1915-3830	H10	S80	SL	
57	D	1915-3830	H50	S80	HC-1, SL	
58	D	1915-3830	H20	S80	HC-1	
59	D	1915-3830	H30	S80	HC-1	
60	D	1915-3830	H40	S80	HC-1	
61	D	1915-3830	H60	S80	HC-1	
62	D	1915-3830	H40	S80	HC-1	
63	D	1915-3830	H50	S80	HC-1, SL	
64	D	1915-3830	H50	S40	G/H	HH: .0762m, GW: 0m
64A	FT	3830	H50	S40	G/H	HH: .0762m, GW: 0m
64B	FT	3830	H10	S40	G/H	HH: .0762m, GW: 0m
65	D	1915-3830	H10	S40	G/H	HH: .0762m, GW: 0m
66	D	1915-3830	H10	S40	G/H	HH: .1270m, GW: .0508m
67	D	1915-3830	H50	S40	G/H	HH: .1270m, GW: .0508m
67A	FT	3830	H50	S40	G/H	HH: .1270m, GW: .0508m
67B	FT	3830	H10	S40	G/H	HH: .1270m, GW: .0508m
67C	FL	1915	H10	S40	G/H	HH: .1270m, GW: .0508m
67D	FL	1915	H10	S40	G/H	HH: .1270m, GW: .0508m
67E	FL	1915	H10	S40	G/H	HH: .1270m, GW: .0508m
67F	FL	1915	H10	S40	G/H	HH: .1270m, GW: .0508m
67G	FL	1915	H10	S40	G/H	HH: .1270m, GW: .0508m
67H	FL	1915	H50	S40	G/H	HH: .1270m, GW: .0508m
67I	FL	1915	H50	S80	HC-1, SL	
67J	FL	1915	H50	S80	HC-1, SL	
67K	FL	1915	H50	S80	HC-1, SL	
67L	FL	1915	H50	S80	HC-1, SL	
67M	FL	1915	H50	S80	HC-1, SL	
67N	FL	1915	H50	S80	HC-1, SL	
67O	FL	1915	H10	S80	SL	
67P	FL	1915	H10	S80	SL	
68	D	1915-3830	H50	S40	G/H	HH: .1524m, GW: .0762m

Run #	Run Type	Dynamic Pressure (Pa)	Hub Fairing	Shaft Fairing	Sweep Type	Notes
69	D	1915-3830	H10	S40	G/H	HH: .1524m, GW: .0762m
70	D	1915-3830	H10	S40	G/H	HH: .1778m, GW: .1016m
71	D	1915-3830	H50	S40	G/H	HH: .1778m, GW: .1016m
71A	FT	3830	H50	S40	G/H	HH: .1778m, GW: .1016m
71B	FT	3830	H10	S40	G/H	HH: .1778m, GW: .1016m
72	D	1915-3830	H10	S40	G/H	HH: .1270m, GW: 0m
73	D	1915,3830	H50	S40	G/H	HH: .1270m, GW: 0m
74	D	1915-3830	H50	S40	G/H	HH: .1270m, GW: 0m
74A	FT	3830	H50	S40	G/H	HH: .1270m, GW: 0m
74B	FT	3830	H10	S40	G/H	HH: .1270m, GW: 0m
74C	FT	3830	H10	S40	G/H	HH: .1524m, GW: .0254m
74D	FT	3830	H50	S40	G/H	HH: .1524m, GW: .0254m
75	D	1915-3830	H50	S40	G/H	HH: .1524m, GW: .0254m
76	D	1915-3830	H10	S40	G/H	HH: .1524m, GW: .0254m
77	D	1915-3830	H10	S40	G/H	HH: .1778m, GW: .0508m
78	D	1915-3830	H50	S40	G/H	HH: .1778m, GW: .0508m
79	D	1915-3830	H50	S40	G/H	HH: .1778m, GW: .0508m
79A	FT	3830	H50	S40	G/H	HH: .1778m, GW: .0508m
79B	FT	3830	H10	S40	G/H	HH: .1778m, GW: .0508m
80	D	1915-3830	H10	S40	G/H	HH: .1524m, GW: .0254m w/ rainshield
81	D	1915-3830	H50	S40	G/H	HH: .1524m, GW: .0254m w/ rainshield
82	D	1915-3830	H50	S40	G/H	HH: .1778m, GW: .0254m w/ rainshield
83	D	1915-3830	H10	S40	G/H	HH: .1778m, GW: .0254m w/ rainshield
83A	FT	3830	H10	S40	G/H	HH: .1778m, GW: .0254m
83B	FT	3830	H50	S40	G/H	HH: .1778m, GW: .0254m

Run #	Run Type	Dynamic Pressure (Pa)	Hub Fairing	Shaft Fairing	Sweep Type	Notes
84	D	1915-3830	H50	S40	G/H	HH: .1778m, GW: .0254m
85	D	1915-3830	H10	S40	G/H	HH: .1778m, GW: .0254m
86	D	1915-3830	H50	S40	G/H	HH: .1524m, GW: 0m
87	D	1915-3830	H220	S40	G/H	HH: .1524m, GW: 0m
88	D	1915-3830	H10	S40	G/H	HH: .1524m, GW: 0m
89	D	1915-3830	H220	S40	HT-D, HC-2	
90	D	1915-3830	H280	S40	HT-T	
91	D	1915-3830	H270	S40	HT-T	
92	D	1915-3830	H260	S40	HT-T	
92A	FT	3830	H260	S40	HT-T	
92B	FT	3830	H270	S40	HT-T	
92C	FT	3830	H280	S40	HT-T	
92D	FT	3830	H220	S40	HT-D, HC-2	
92E	FT	3830	H230	S40	HT-D	
93	D	1915-3830	H230	S40	HT-D	
94	D	1915-3830	H250	S40	HT-T	
94A	FT	3830	H250	S40	HT-T	
94B	FT	3830	H240	S40	HT-T	
95	D	1915-3830	H240	S40	HT-T	
96	D	1915-3830	H50	S40	G/H	HH: .1524m, GW: .0762m w/ rainshield
97	D	1915-3830	H10	S40	G/H	HH: .1524m, GW: .0762m w/ rainshield
98	D	1915-3830	H10	S40	G/H	HH: .1778m, GW: .1016m w/ rainshield
99	D	1915-3830	H50	S40	G/H	HH: .1778m, GW: .1016m w/ rainshield
100	D	1915-3830	H50	S40	G/H	HH: .1524m, GW: .0508m w/ rainshield

Run #	Run Type	Dynamic Pressure (Pa)	Hub Fairing	Shaft Fairing	Sweep Type	Notes
101	D	1915-3830	H10	S40	G/H	HH: .1524m, GW: .0508m w/ rainshield
102	D	1915-3830	H10		US	
103	D	1915-3830	H50		US	
104	D	1915-3830	HD1-1			
107	D	1915-3830	H50	S40	Many	
108	D	1915-3830	H20	S40	HC-1	
109	D	1915-3830	H30	S40	HC-1	
110	D	1915-3830	H40	S40	HC-1	
111	D	1915-3830	H60	S40	HC-1	
111A	FO	1915	H50	S40	Many	
111B	FO	1915, 3830	H50	S40	Many	
111C	FO	1915	H10	S40	Many	
115	D	1915-3830	H60	S200	MC	SF w/ contour
115A	FT	3830	H60	S200	MC	SF w/ contour
115B	FT	3830	H60	S200	MC	SF w/ contour
115C	FT	3830	H50	S200	MC	SF w/ contour
116	D	1915-3830	H50	S200	MC	SF w/ contour
117	D	1915-3830	H50	S200	MC	SF w/o contour
117A	FT	3830	H50	S200	MC	SF w/o contour
117B	FT	3830	H60	S200	MC	SF w/o contour
118	D	1915-3830	H60	S200	MC	SF w/o contour
119	D	1915-3830	H60	S200	SE	TE: .1067m SF w/ contour
120	D	1915-3830	H60	S200	SE	TE: .2311m SF w/ contour
120A	FT	3830	H60	S200	SE	TE: .1067m SF w/ contour
120B	FT	3830	H60	S200	SE	TE: .1067m SF w/ contour

Run #	Run Type	Dynamic Pressure (Pa)	Hub Fairing	Shaft Fairing	Sweep Type	Notes
120C	FT	3830	H60	S200	SE	TE: .2311m, LE: .0889m SF w/ contour
121	D	1915-3830	H60	S200	SE	TE: .2311m, LE: .0889m SF w/ contour
122	D	1915-3830	H60	S200	SE	TE: .2311m, LE: .1753m SF w/ contour
122A	FT	3830	H60	S200	SE	TE: .2311m, LE: .1753m SF w/ contour
122B	FT	3830	H60	S200	SE	TE: .2311m, LE: .1753m SF w/ contour
122C	FT	3830	H2	S40	BS1	0 degrees
123	D	1915-3830	H2	S40	BS1	0 degrees
124	D	1915-3830	H4	S40	BS1	0 degrees
124A	FT	3830	H4	S40	BS1	0 degrees
124B	FT	3830	H4	S40	BS1	0 degrees Cutouts filled w/ clay
125	D	1915-3830	H4	S40	BS1	0 degrees Cutouts filled w/ clay
126	D	1915-3830	H2	S40	BS1	22.5 degrees
126A	FT	3830	H2	S40	BS1	22.5 degrees
127	D	1915-3830	H4	S40	BS1	22.5 degrees
127A	FT	3830	H4	S40	BS1	22.5 degrees
127B	FL	1915	H4	S40	BS1	22.5 degrees
127C	FL	1915	H50	S40	Many	
128	D	1915-3830	H4	S40	BS1	22.5 degrees Cutouts filled w/ clay
129	D	1915-3830	H2	S40	BS1	45 degrees
129A	FT	3830	H2	S40	BS1	45 degrees
130	D	1915-3830	H4	S40	BS1	45 degrees
130A	FT	3830	H4	S40	BS1	45 degrees
131	D	1915-3830	H4	S40	BS1	45 degrees Cutouts filled w/ clay
132	D	1915-3830	H2	S40	BS1	67.5 degrees

Run #	Run Type	Dynamic Pressure (Pa)	Hub Fairing	Shaft Fairing	Sweep Type	Notes
132A	FT	3830	H2	S40	BS1	67.5 degrees
133	D	1915-3830	H4	S40	BS1	67.5 degrees
133A	FT	3830	H4	S40	BS1	67.5 degrees
134	D	3830	H4	S40	BS1	67.5 degrees Cutouts filled w/ clay
134A	FT	3830	H100	S40	HCC	
134B	FT	3830	H110	S40	HCC	
134C	FT	3830	H130	S40	HCC	
134D	FT	3830	H140	S40	HCC	
134E	FT	3830	H150	S40	HSC	
135	D	1915-3830	H150	S40	HSC	
136	D	1915-3830	H100	S40	HCC	
137	D	1915-3830	H110	S40	HCC	
138	D	1915-3830	H130	S40	HCC	
139	D	1915-3830	H140	S40	HCC	
140	D	1915-3830	H100	S40	HCC	
141	D	1915-3830	H50	S40	Many	
142	D	1915-3830	H110	S40	HCC	
143	D	1915-3830	H130	S40	HCC	
144	D	1915-3830	H140	S40	HCC	
145	D	1915-3830	H10	S40	Many	
146	D	1915-3830	H150	S40	HSC	
147	D	1915-3830	H280	S40	HT-T	
148	D	1915-3830	H270	S40	HT-T	
149	D	1915-3830	H260	S40	HT-T	
150	D	1915-3830	H220	S40	HT-D, HC-2	

Run #	Run Type	Dynamic Pressure (Pa)	Hub Fairing	Shaft Fairing	Sweep Type	Notes
151	D	1915-3830	H250	S40	HT-T	
152	D	1915-3830	H210	S40	HSC	
153	D	1915-3830	H160	S40	HSC	
154	D	1915-3830	H240	S40	HT-T	
154A	FO	3830	HD1-1	S40		
154B	FO	3830	HD1-2	S40		
155	D	1915-3830	HD1-2	S40		
156	D	1915-3830	HD1-1	S40		
157	D	1915-3830	H160	S40	HSC	
157A	FT	3830	H160	S40	HSC	
158	D	1915-3830	H210	S40	HSC	
159	D	1915-3830	H52	S40	GR	
160	D	1915-3830	H50	S40	GR	SF w/ fence w/o rainshield
160A	FT	3830	H50	S40	GR	SF w/ fence w/o rainshield
161	D	1915-3830	H54	S40	IS	
161A	FT	3830	H54	S40	IS	
162	D	1915-3830	H54	S40	GR	Modified H54, notch filled w/ clay
163	D	1915-3830	H50	S40	IS	Shaft inclined 5 degrees.
164	D	1915-3830	H10	S40	IS	Shaft inclined 5 degrees.
165	D	1915-3830	H54	S40	IS	
166	D	1915-3830	H50	S40	IS	Shaft inclined 5 degrees. One SF wedge removed, w/ .0254m gap

Run #	Run Type	Dynamic Pressure (Pa)	Hub Fairing	Shaft Fairing	Sweep Type	Notes
167	D	1915-3830	H10	S40	IS	Shaft inclined 5 degrees. One SF wedge removed, w/ .0254m gap
168	D	1915-3830	H50	S40	IS	Shaft inclined 5 degrees. Two SF wedges removed, w/ .0508m gap
169	D	1915-3830	H10	S40	IS	Shaft inclined 5 degrees. Two SF wedges removed, w/ .0508m gap
170	D	1915-3830	H50	S40	IS	Shaft inclined 5 degrees. Two SF wedges removed, w/o gap.
170A	FT	3830	H50	S40	IS	Shaft inclined 5 degrees. Two SF wedges removed, w/o gap.
171	D	1915-3830	H10	S40	IS	Shaft inclined 5 degrees. Two SF wedges removed, w/o gap.
172	D	1915-3830	H50	S40	IS	Shaft inclined 5 degrees. One SF wedge removed, w/o gap.
173	D	1915-3830	H10	S40	IS	Shaft inclined 5 degrees. One SF wedge removed, w/o gap.
174	D	1915-3830		S40	SFT	
174A	FT	3830		S40	SFT	
174B	FT	3830		S40	SFT	
175	D	1915-3830		S40	SFT	
176	D	1915-3830	H4	S40	BS2	45 degrees
177	D	1915-3830	H2	S40	BS2	45 degrees

Run #	Run Type	Dynamic Pressure (Pa)	Hub Fairing	Shaft Fairing	Sweep Type	Notes
178	D	1915-3830	H2	S40	BS2	0 degrees
179	D	1915-3830	H4	S40	BS2	0 degrees
180	D	1915-3830	H4	S40	BS2/IS	Shaft inclined 5 degrees. One SF wedge removed, w/o gap. Shanks at 0 degrees.
181	D	1915-3830	H2	S40	BS2/IS	Shaft inclined 5 degrees. One SF wedge removed, w/o gap. Shanks at 0 degrees.
181A	FT	1915-3830	H4	S40	BS2/IS	Shaft inclined 5 degrees. One SF wedge removed, w/o gap. Shanks at 0 degrees.
186	D	1915-3830	See text!	See text!	C	Upper Hub Fairing m = 0.17
187	D	1915-3830	See text!	See text!	C	Upper Hub Fairing H50, m = 0.09
188	D	1915-3830	See text!	See text!	C	Upper Hub Fairing H220, m = 0.12
189	D	1915-3830	See text!	See text!	C	Upper Hub Fairing H230, m = 0.15
190	D	1915-3830	See text!	See text!	C	Upper Hub Fairing H80, m = 0.00
191	D	1915-3830		S40	SFT	SF Height: .0762m
192	D	1915-3830		S40	SFT	SF Height: .1016m
193	D	1915-3830		S40	SFT	SF Height: .1270m
194	D	1915-3830		S40	SFT	SF Height: .0254m
195	D	1915-3830		S140	SFT	
196	D	1915-3830		S150	SFT	

Run #	Run Type	Dynamic Pressure (Pa)	Hub Fairing	Shaft Fairing	Sweep Type	Notes
197	D	1915-3830	H50	S120	SFC	
198	D	1915-3830	H50	S130	SFC	
199	D	1915-3830		S20	SFT	
200	D	1915-3830		S10	SFT	
201	D	1915-3830		S30	SFT	
202	D	1915-3830		S50	SFT	
203	D	1915-3830		S60	SFT	
204	D	1915-3830		S70	SFT	
205	D	1915-3830		S80	SFT	
206	D	1915-3830		S100	SFT	
207	D	1915-3830		S110	SFT	
208	D	1915-3830	H50	S110	SL	
209	D	1915-3830	H10	S110	SL	
210	D	1915-3830	H10	S100	SL	
211	D	1915-3830	H50	S100	SL	
212	D	1915-3830	H50	S50	SL	
213	D	1915-3830	H10	S50	SL	
214	D	1915-3830	H10	S60	SL	
215	D	1915-3830	H50	S60	SL	
216	D	1915-3830	H50	S10	SS	
217	D	1915-3830	H10	S10	SS	
218	D	1915-3830	H10	S20	SS	

Run #	Run Type	Dynamic Pressure (Pa)	Hub Fairing	Shaft Fairing	Sweep Type	Notes
219	D	1915-3830	H50	S20	SS	
220	D	1915,3830	H50	S30	SS	
221	D	1915-3830	H10	S30	SS	
222	D	1915-3830	H10	S40	Many	
223	D	1915-3830	H50	S40	Many	
224	D	1915-3830	H50	S70	SL	
225	D	1915-3830	H10	S70	SL	
226	D	1915-3830	H10	S80	SL	
227	D	1915-3830	H50	S80	SL,HC-1	
228	D	1915-3830	H230	S80	HT-D	
229	D	1915-3830			CF	
232	D	1915	H110		IHF	
234	D	1915	H50		IHF	
235	D	1915	H210		IHF	
236	D	1915	H140		IHF	
237	D	1915	H130		IHF	
238	D	1915	H150		IHF	
239	D	1915	H40		IHF	
240	D	1915	H30		IHF	
241	D	1915	H10		IHF	
242	D/FT	1915	H160		IHF	
242A	FT	1915	H110		IHF	

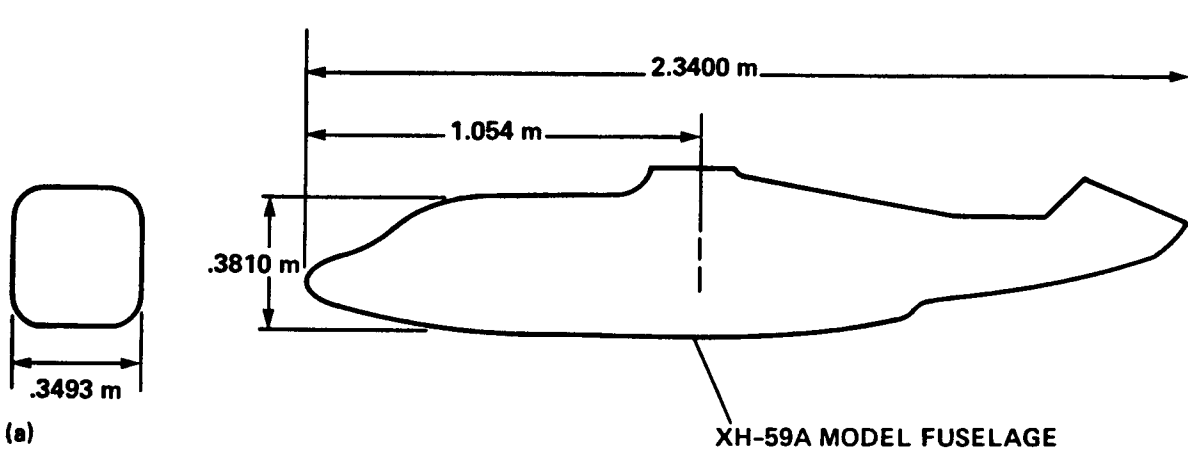

Figure 1(a).- Model dimensions.

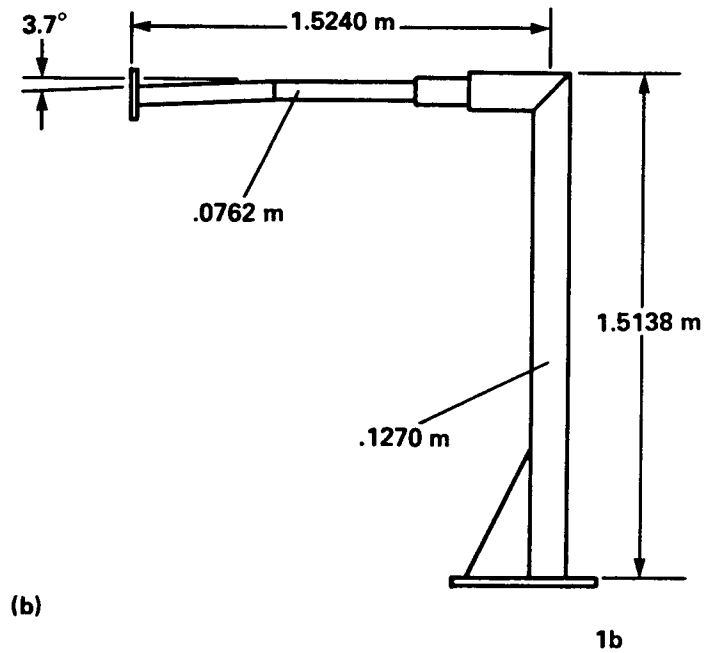

Figure 1(b).- Dimensions of the sting.

PRECEDING PAGE BLANK NOT FILMED

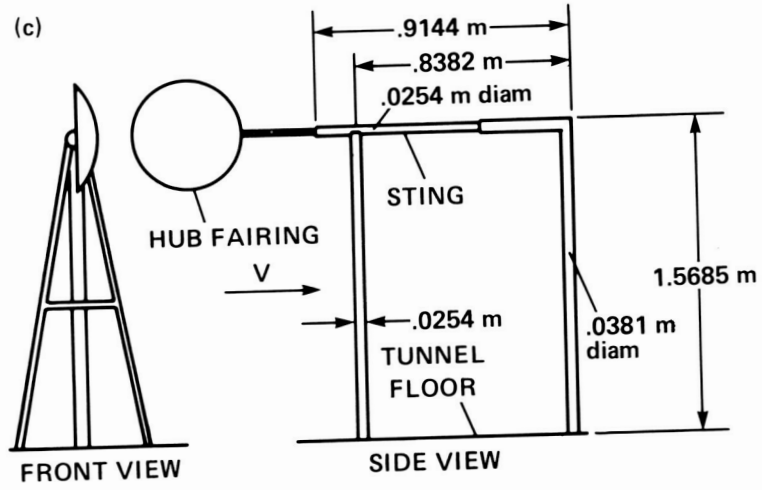

Figure 1(c).- Dimensions of the sting used in the isolated hub fairing test.

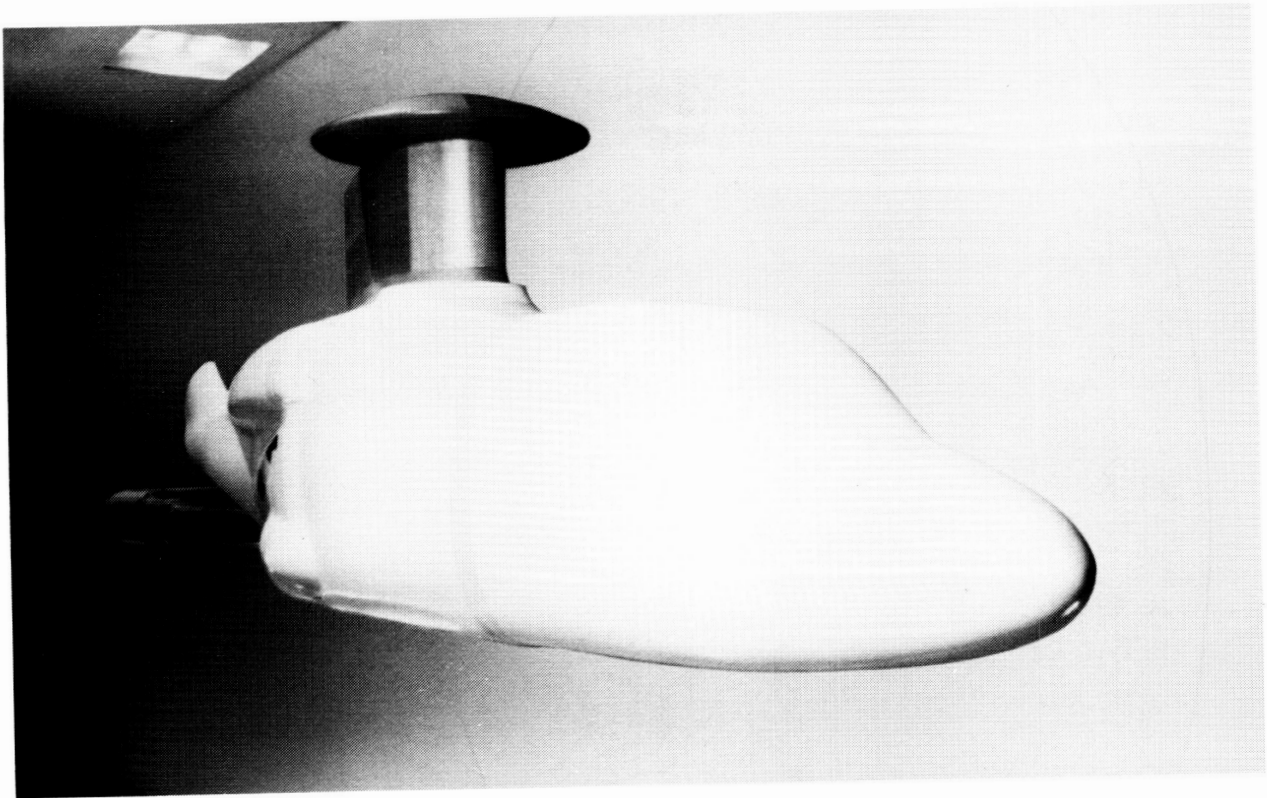

Figure 1(d).- Model installation photograph.

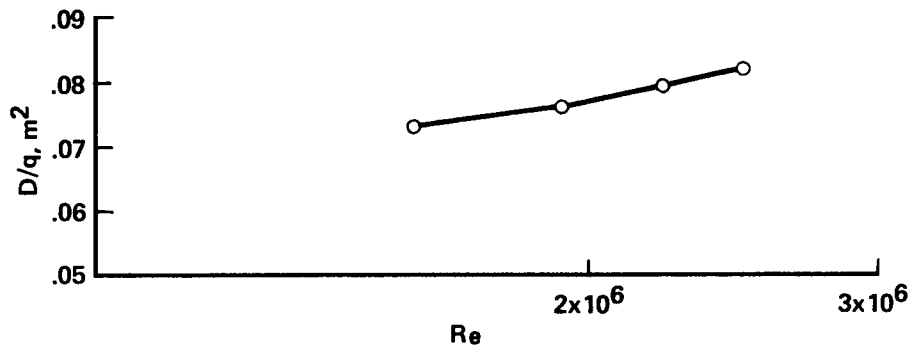

Figure 2.— Reynolds number effects, Run 87-H220, S40.

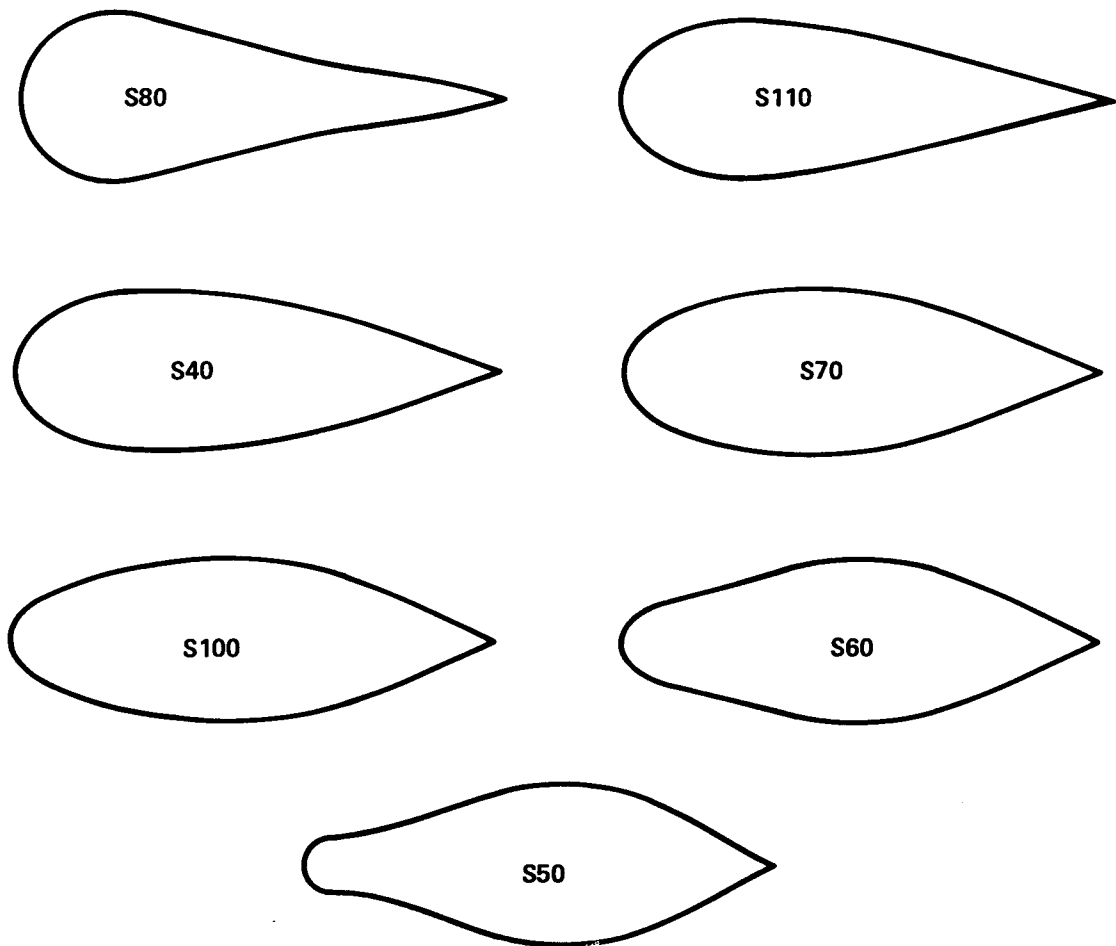

Figure 3.— Shaft fairing cross sections: variation of location of maximum thickness.

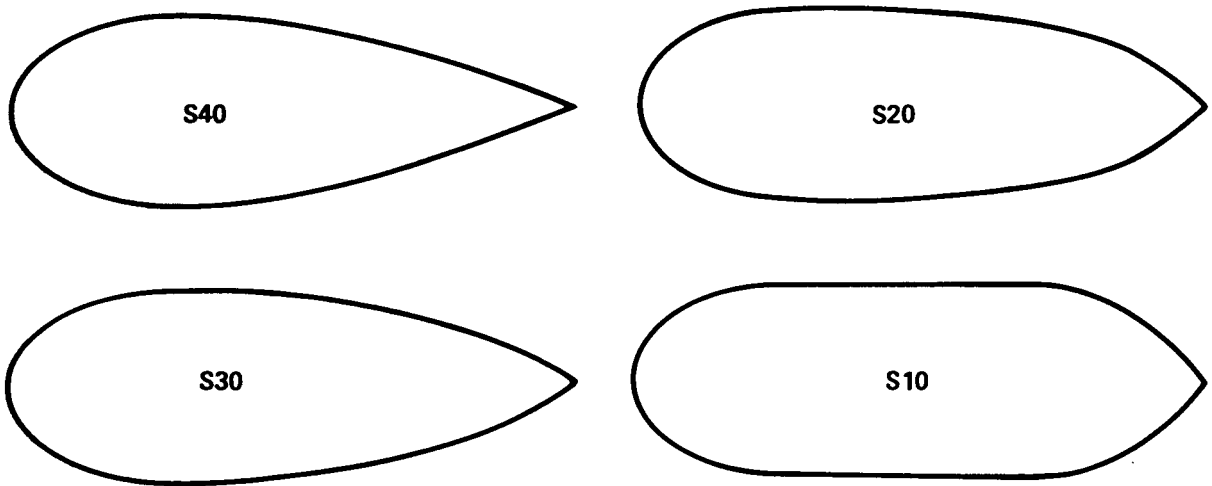

Figure 4.- Shaft fairing cross sections: variation of trailing edge slope.

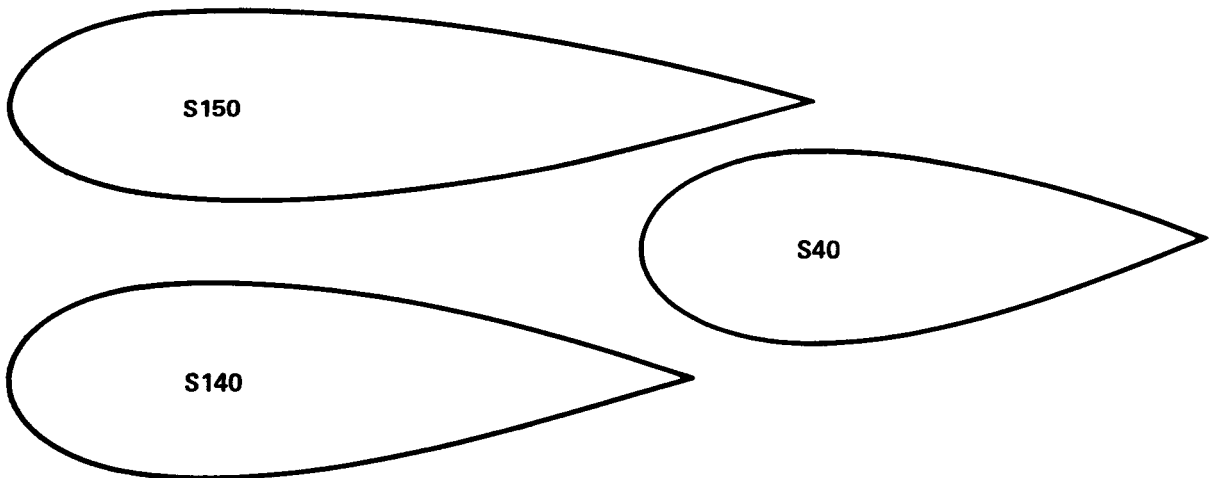

Figure 5.- Shaft fairing cross sections: variation of thickness ratio.

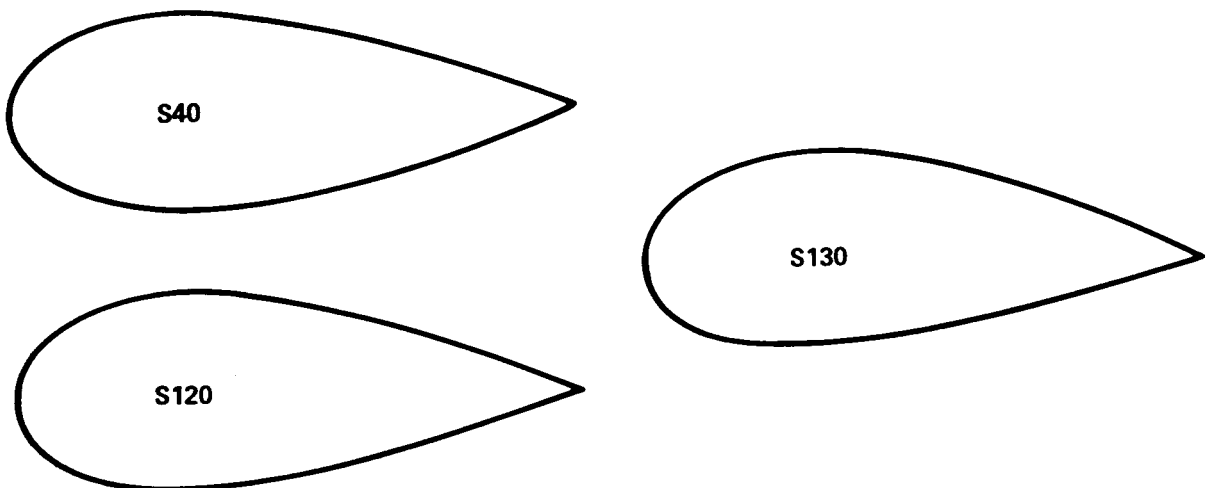

Figure 6.- Shaft fairing cross sections: variation of camber.

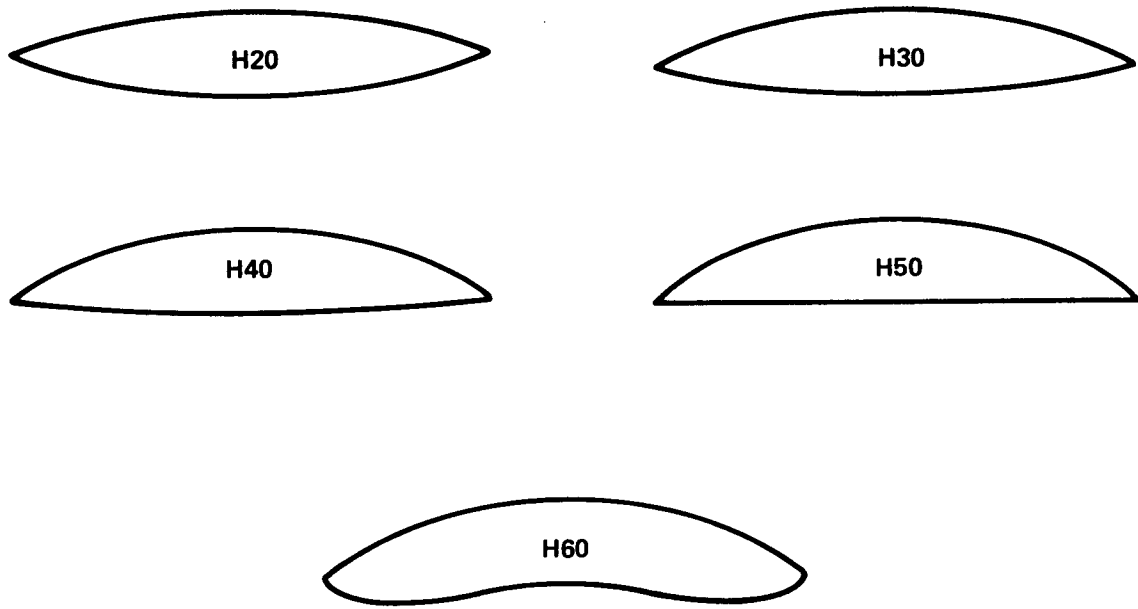

Figure 7.— Hub fairing cross sections: variation of camber.

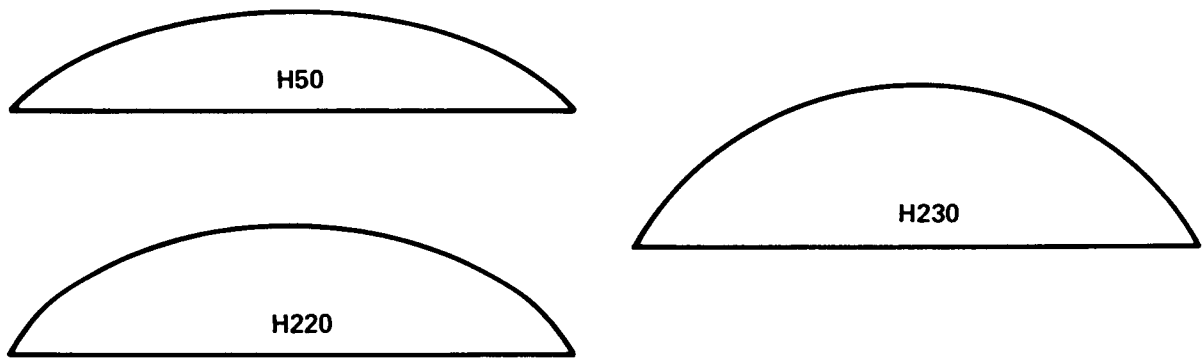

Figure 8.— Hub fairing cross sections: variation of maximum thickness ratio and camber (constant diameter).

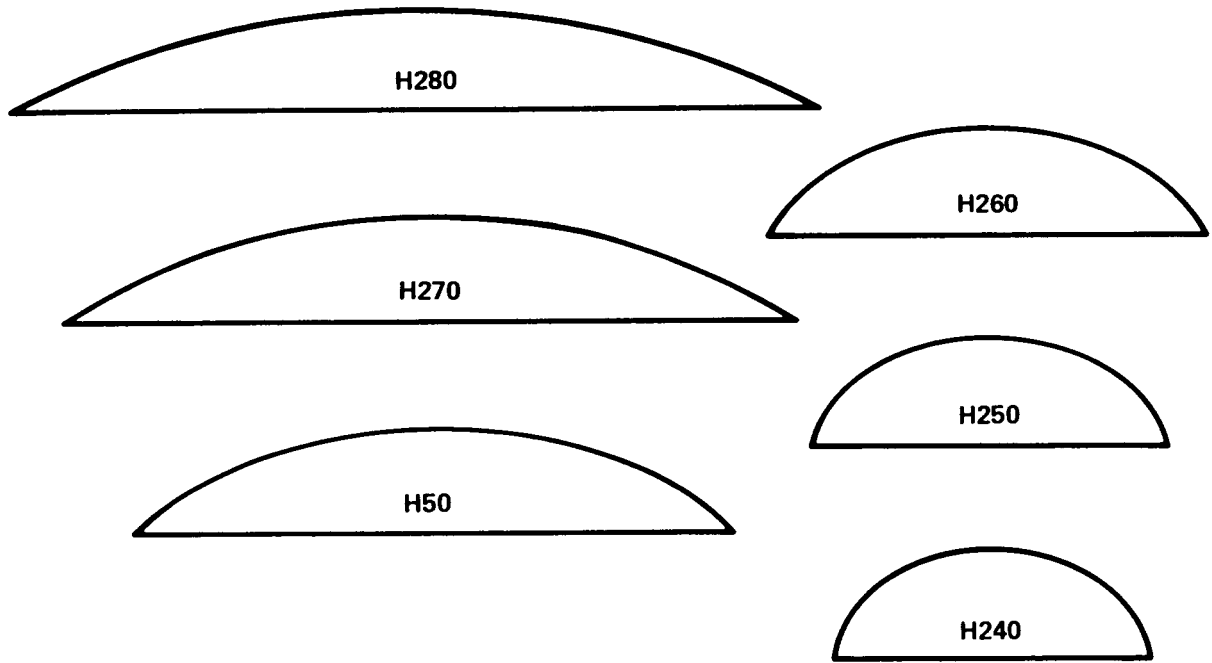

Figure 9.— Hub fairing cross sections: variations of thickness ratio and camber (constant thickness).

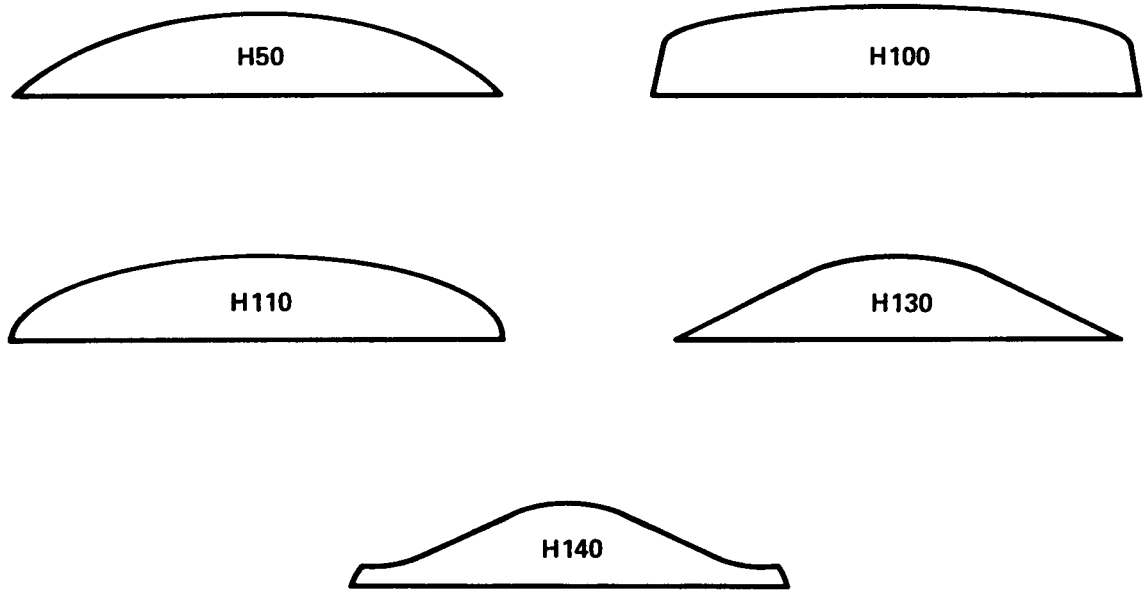

Figure 10.— Hub fairing cross sections: variation of upper surface curvature (flat lower surface).

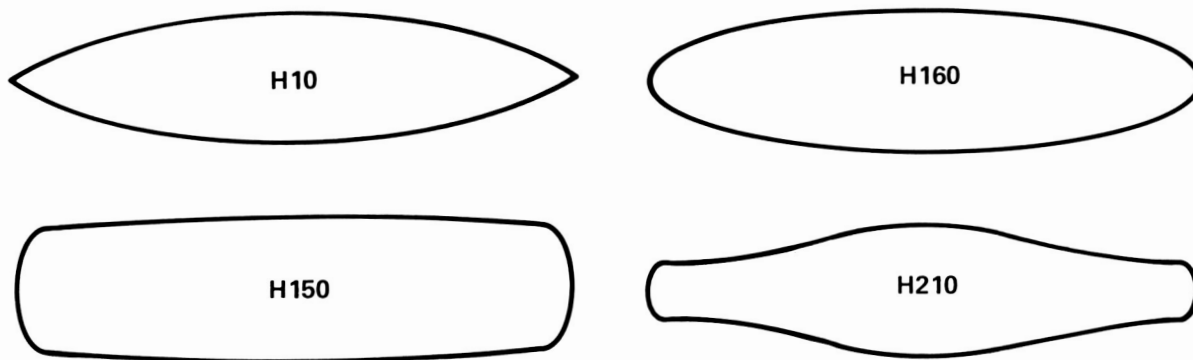

Figure 11.- Hub fairing cross sections: variations of upper and lower surface curvature (symmetrical).

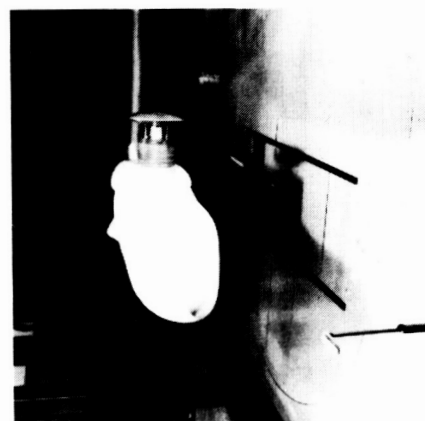
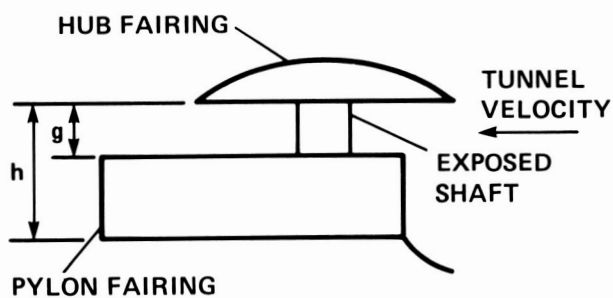

Figure 12.- Configuration with gap between hub fairing and pylon. (a) Side view of the test configuration. (b) Picture of the test configuration with hub/pylon gap.

ORIGINAL PAGE IS
OF POOR QUALITY

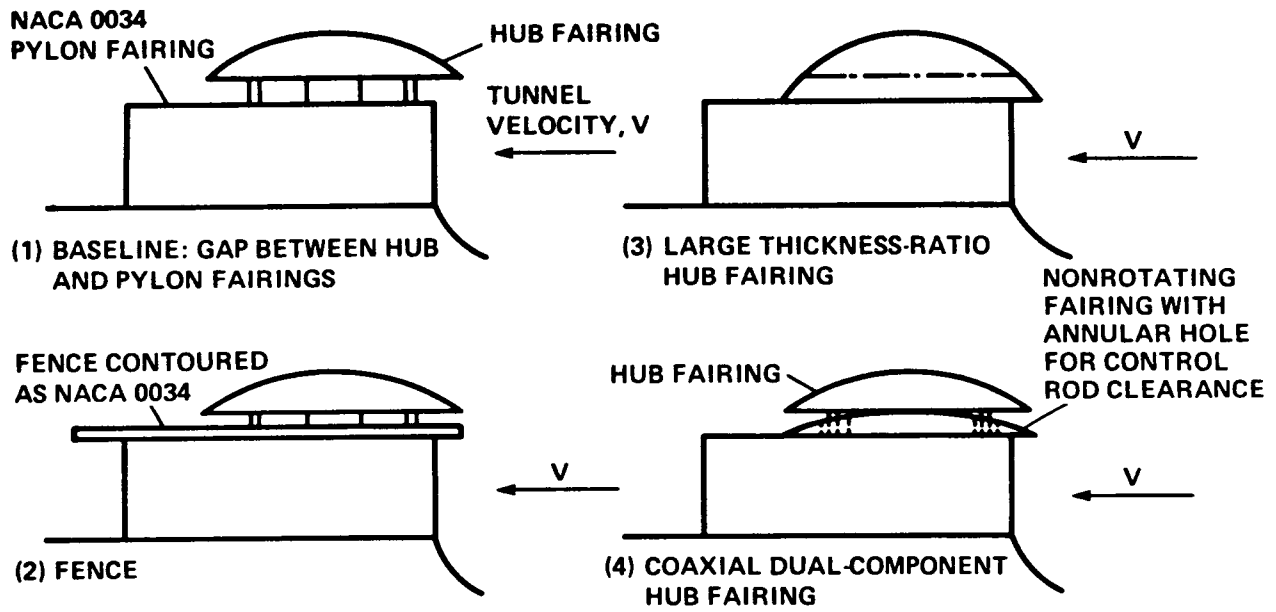

Figure 13.- Hub/pylon fairing gap width remedies.

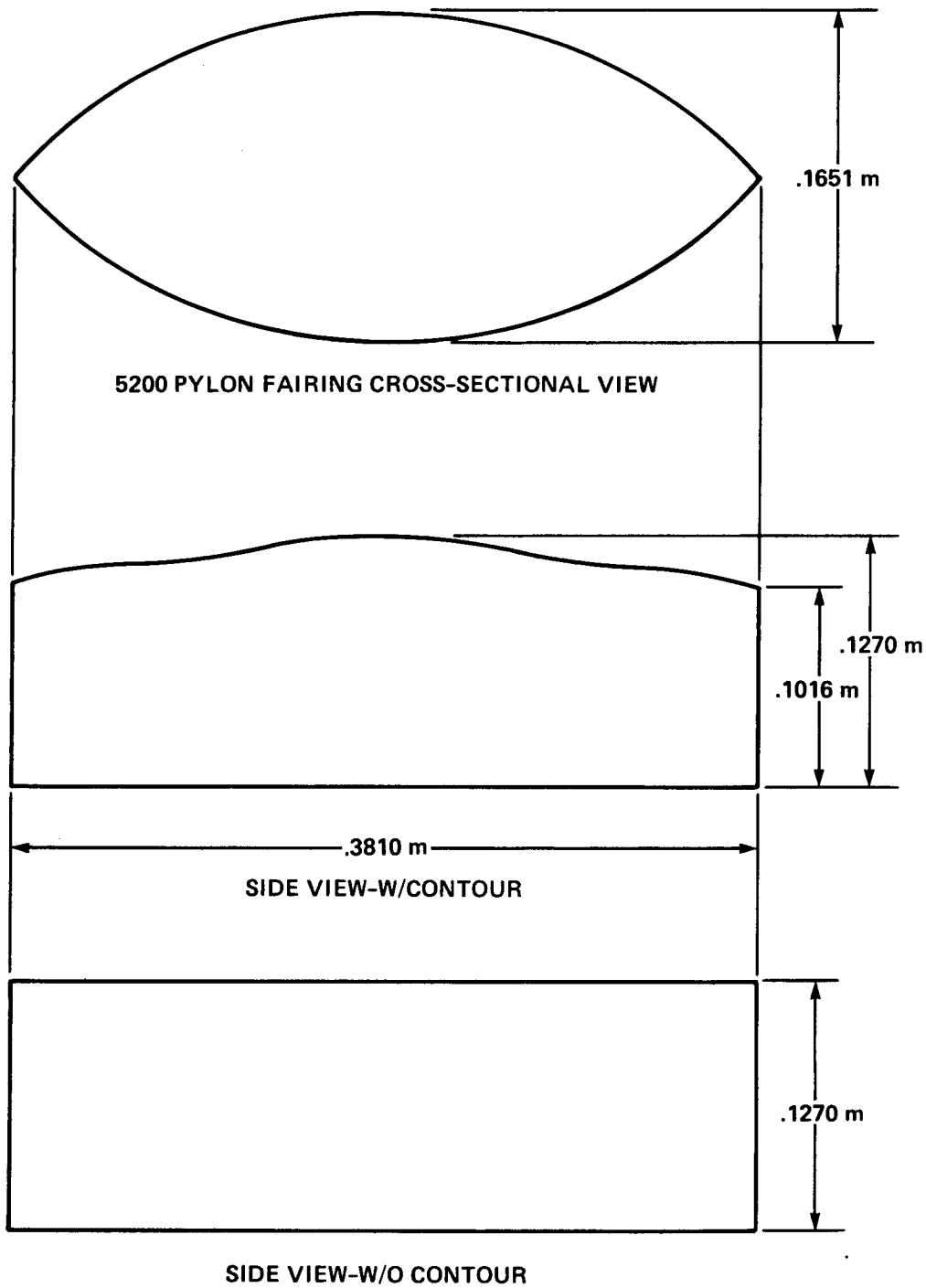

Figure 14.- Matching contour pylon fairing.

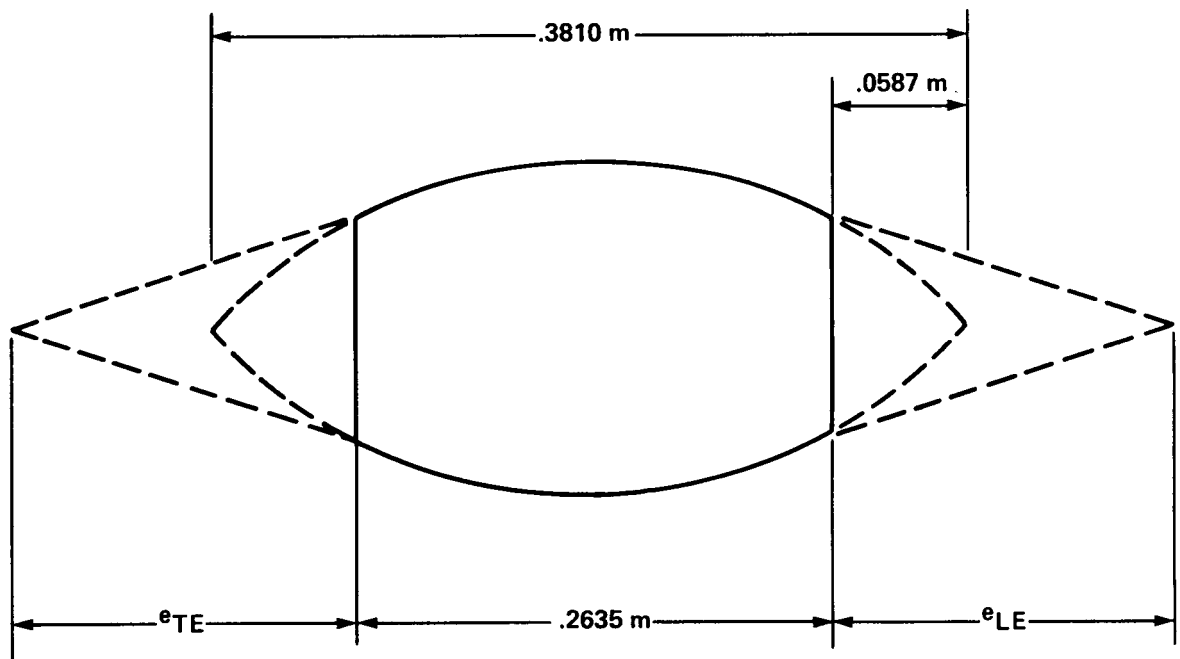
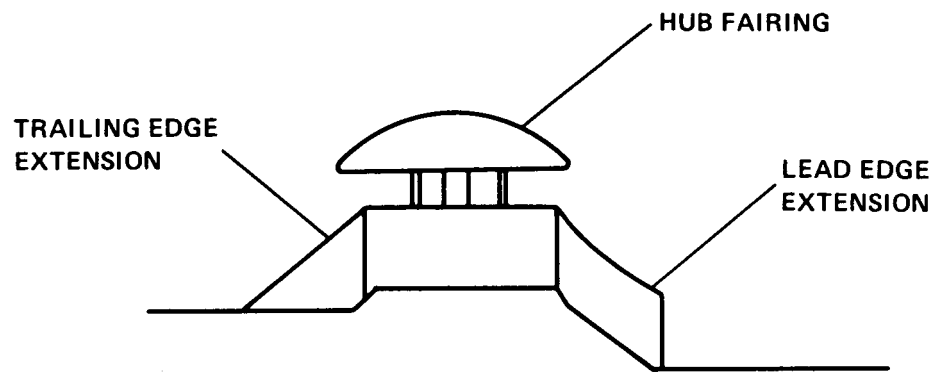

Figure 15.- Pylon leading and trailing edge extension.

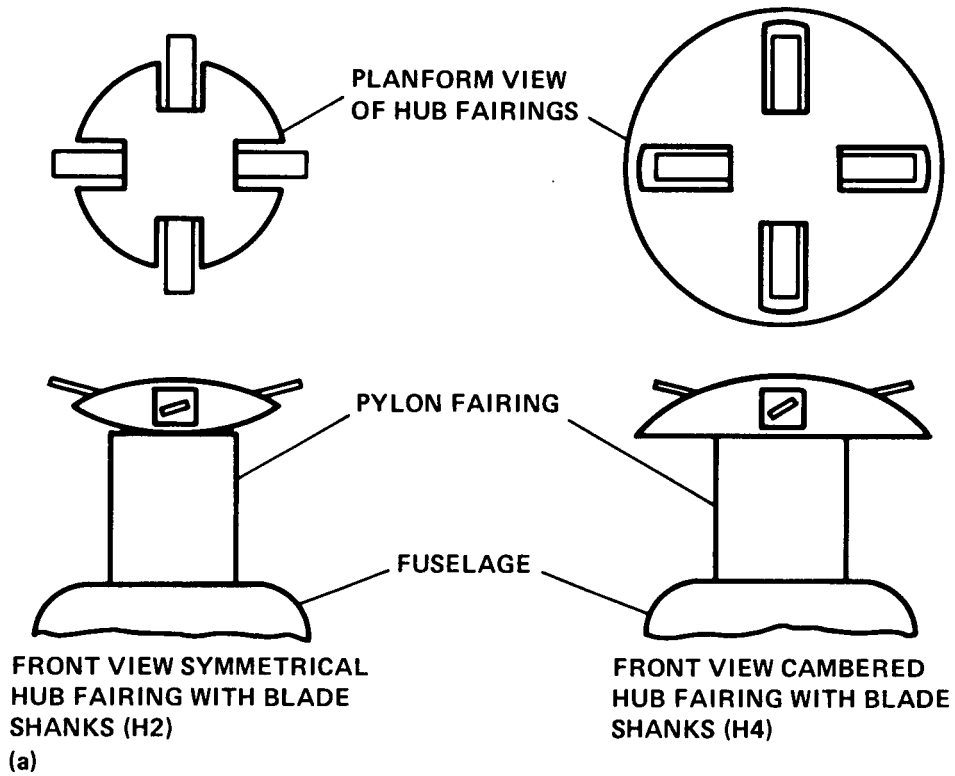

Figure 16.— Hub fairings with blade shanks incorporated. (a) Front views of the test configurations with blade shank Sets #1 and #2.

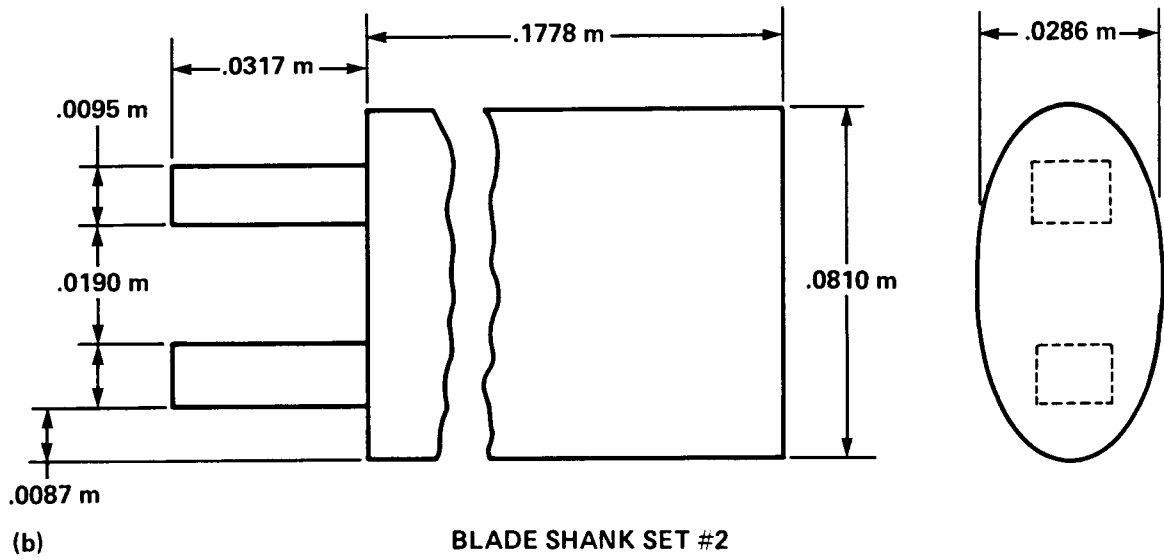
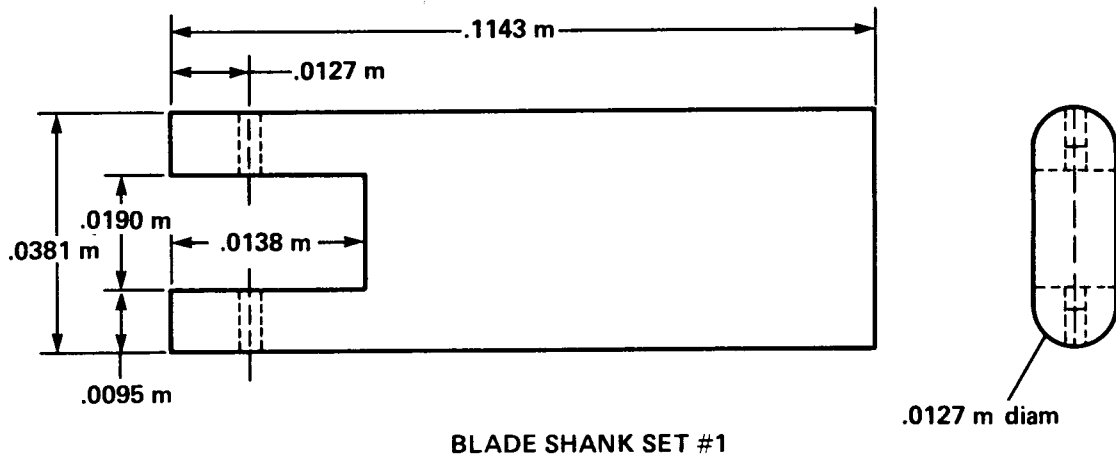

Figure 16.- Concluded. (b) Dimensions of the blade shank Sets #1 and #2.

ORIGINAL PAGE IS
OF POOR QUALITY

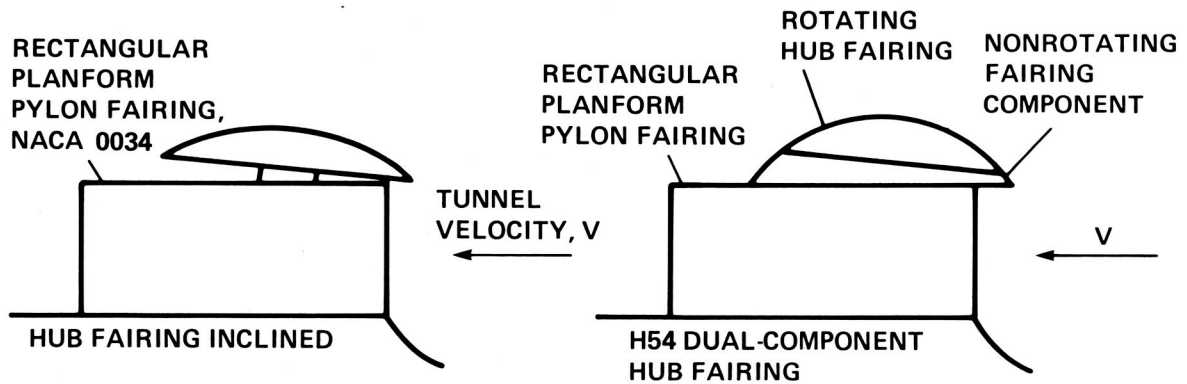

Figure 17.- Inclined rotor shaft configuration.

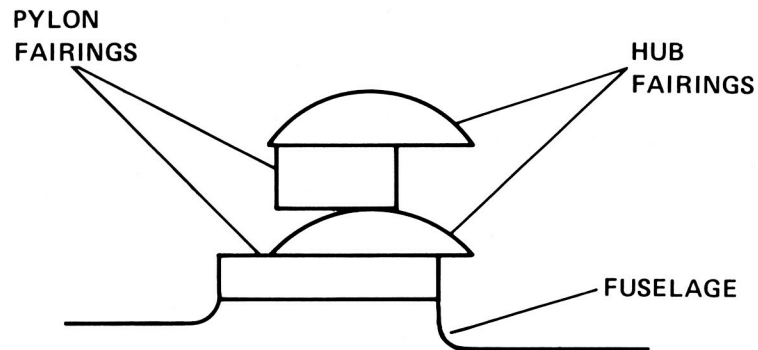

Figure 18.- Typical coaxial rotor hub fairing configuration.



Figure 19.- Oil flow (H50, S40) side view.



Figure 20.— Oil flow (H50, S40) top view.



(a)



(b)

Figure 21.— Laser sheet (H50,S40). (a) At the trailing edge of the pylon. (b) At a downstream location.

ORIGINAL PAGE IS
OF POOR QUALITY

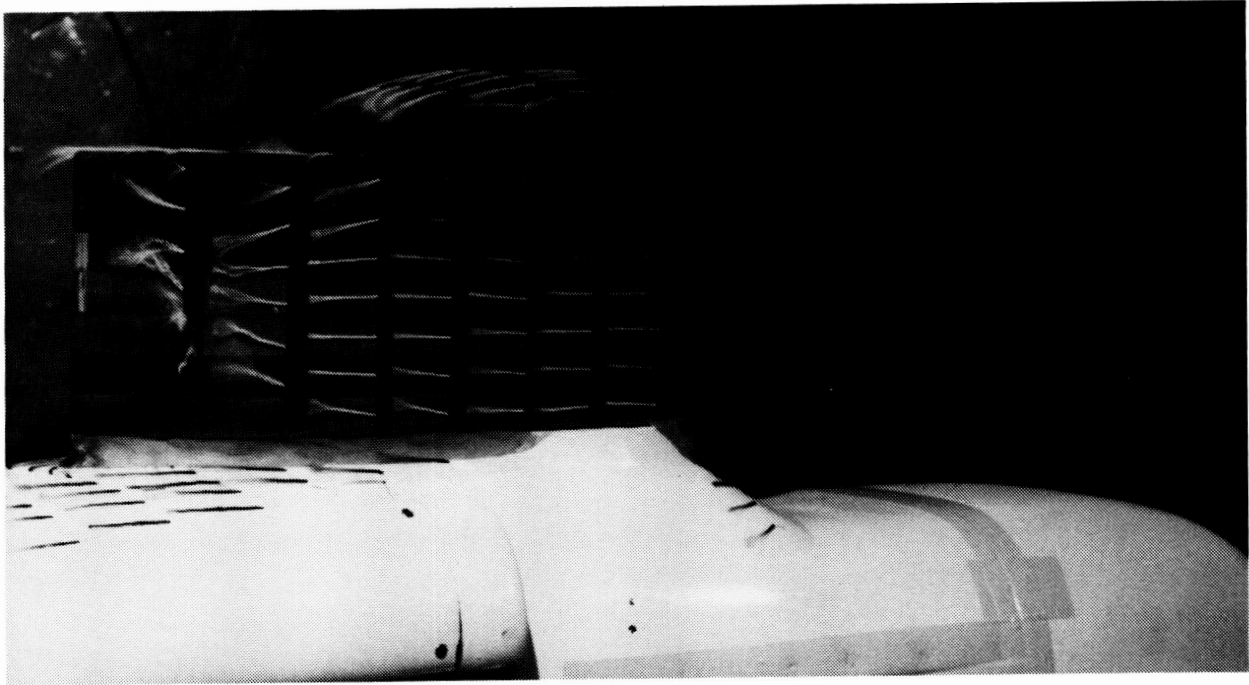

Figure 22.— Tufting flow of configuration H10, S10.

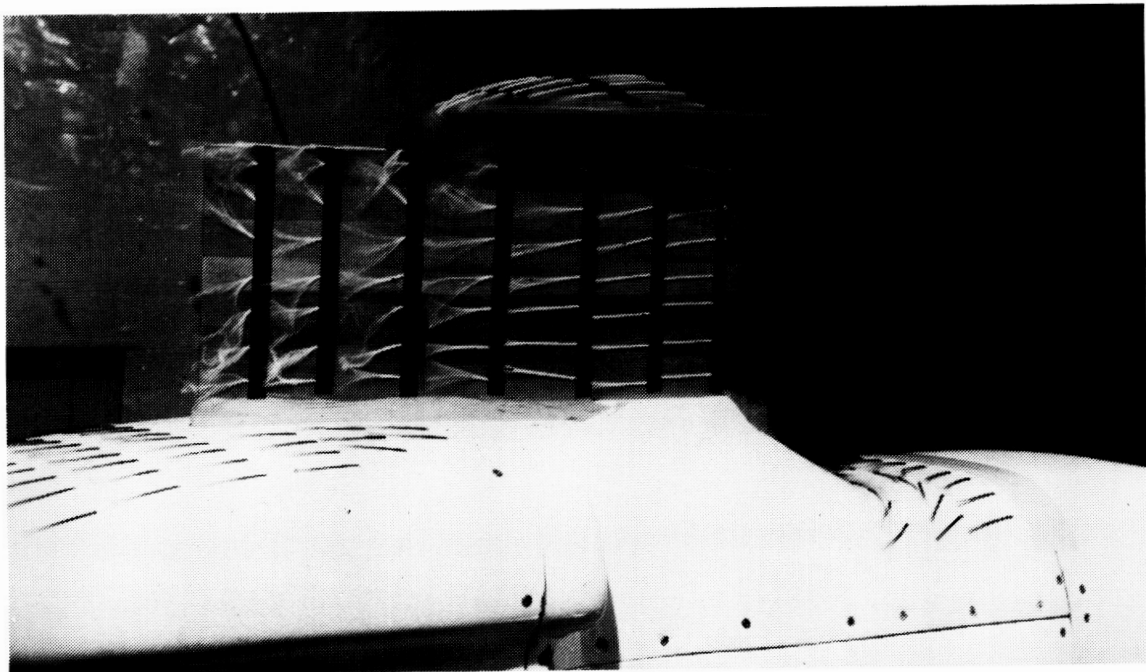

Figure 23.— Tufting flow of configuration H10, S40.



Figure 24.- Tufting flow of configuration H10, S50.



Figure 25.- Tufting flow of configuration H10, S60.

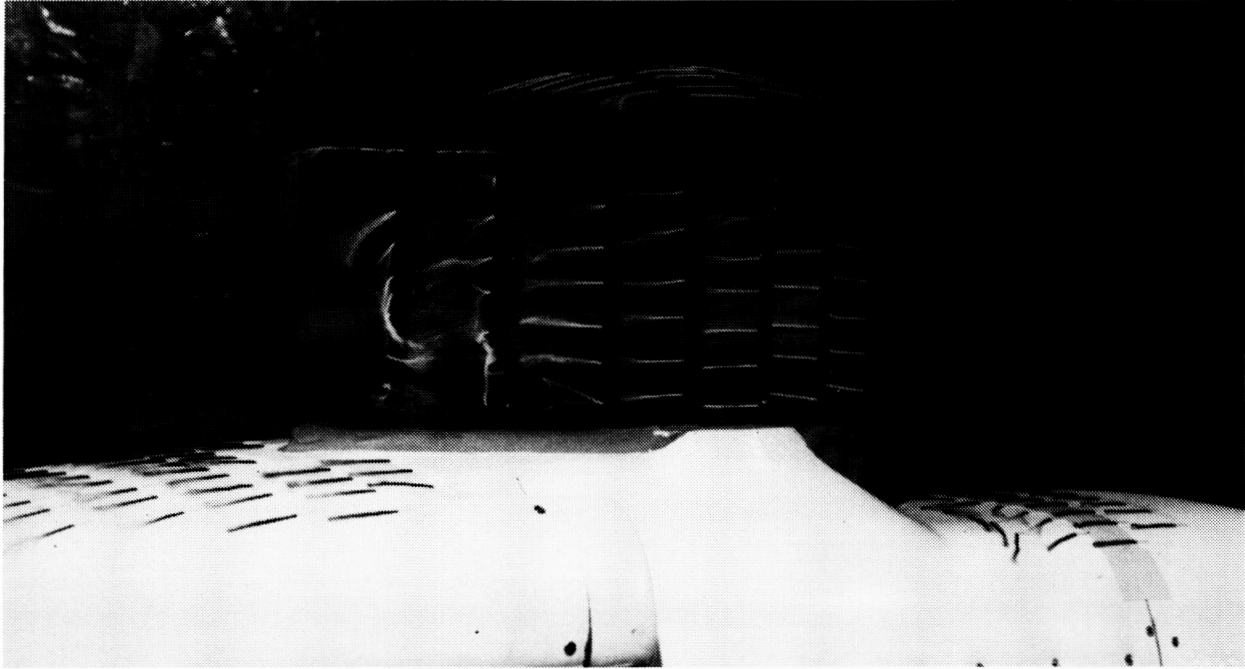

Figure 26.— Tufting flow of configuration H10, S70.

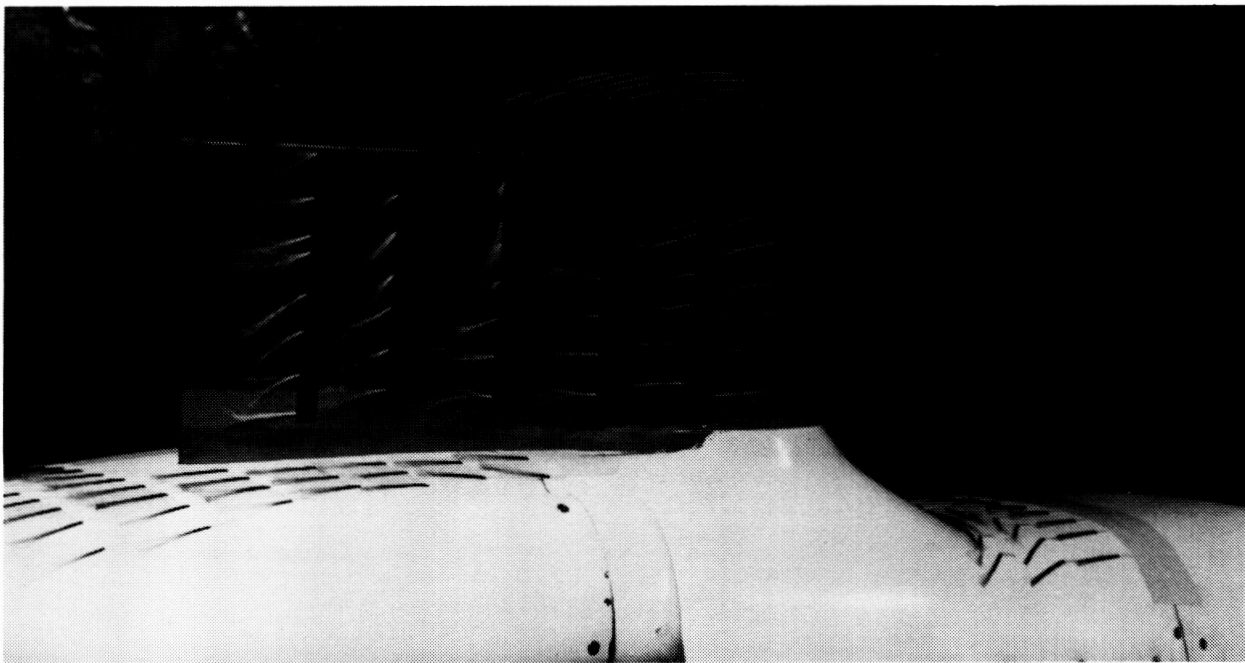

Figure 27.— Tufting flow of configuration H10, S80.

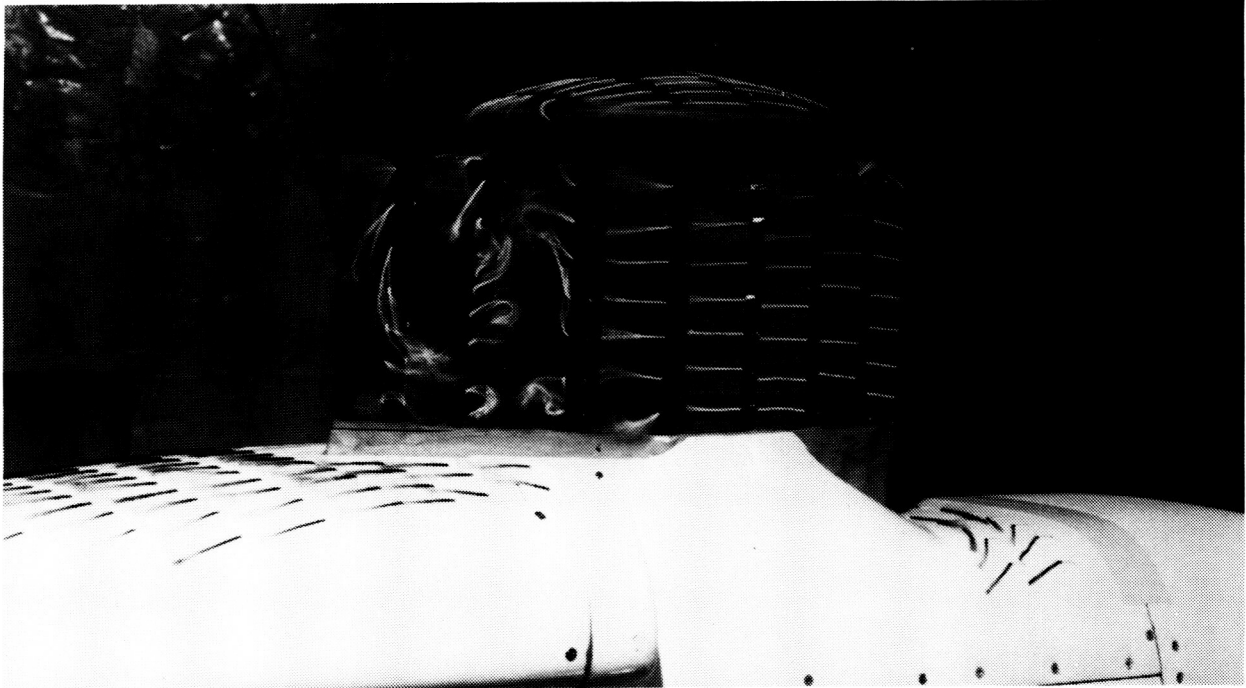

Figure 28.— Tufting flow of configuration H10, S100.

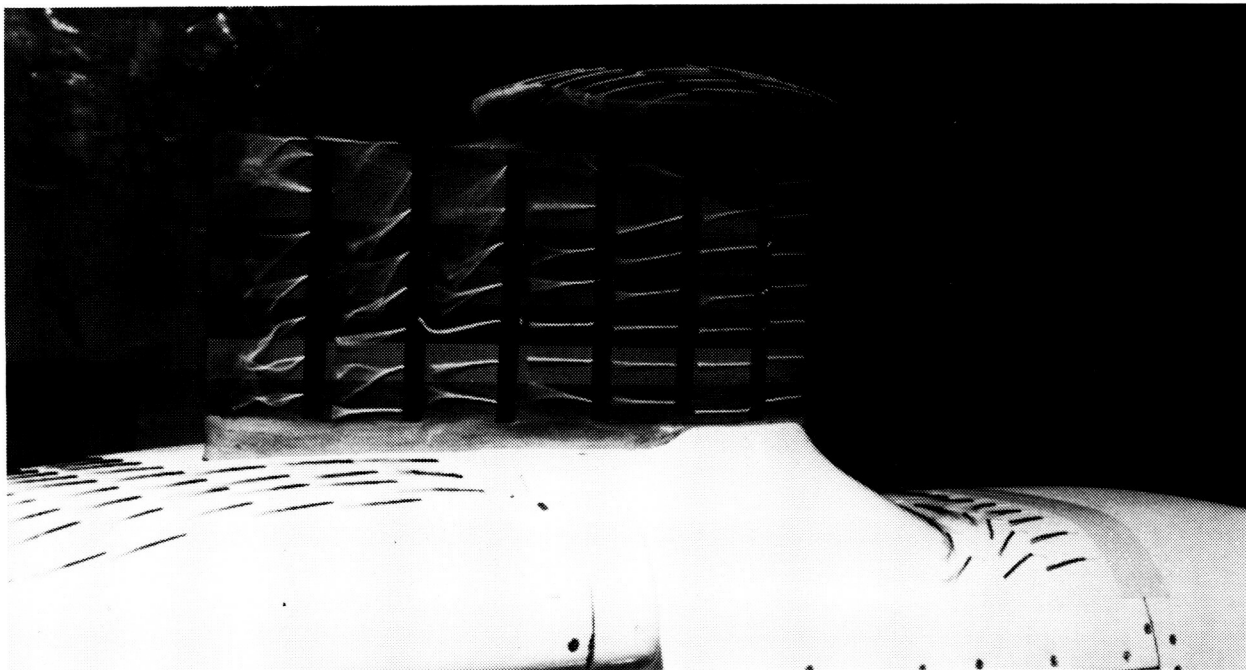

Figure 29.— Tufting flow of configuration H10, S110.

ORIGINAL PAGE IS
OF POOR QUALITY

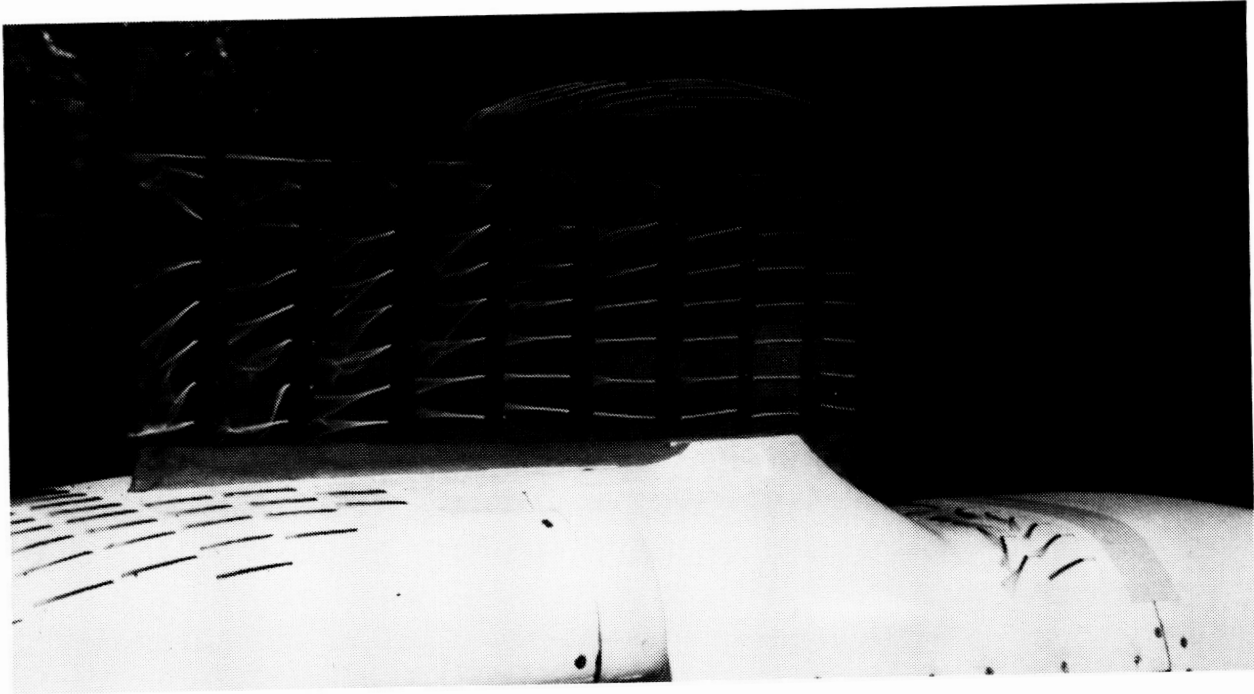

Figure 30.— Tufting flow of configuration H10, S140.

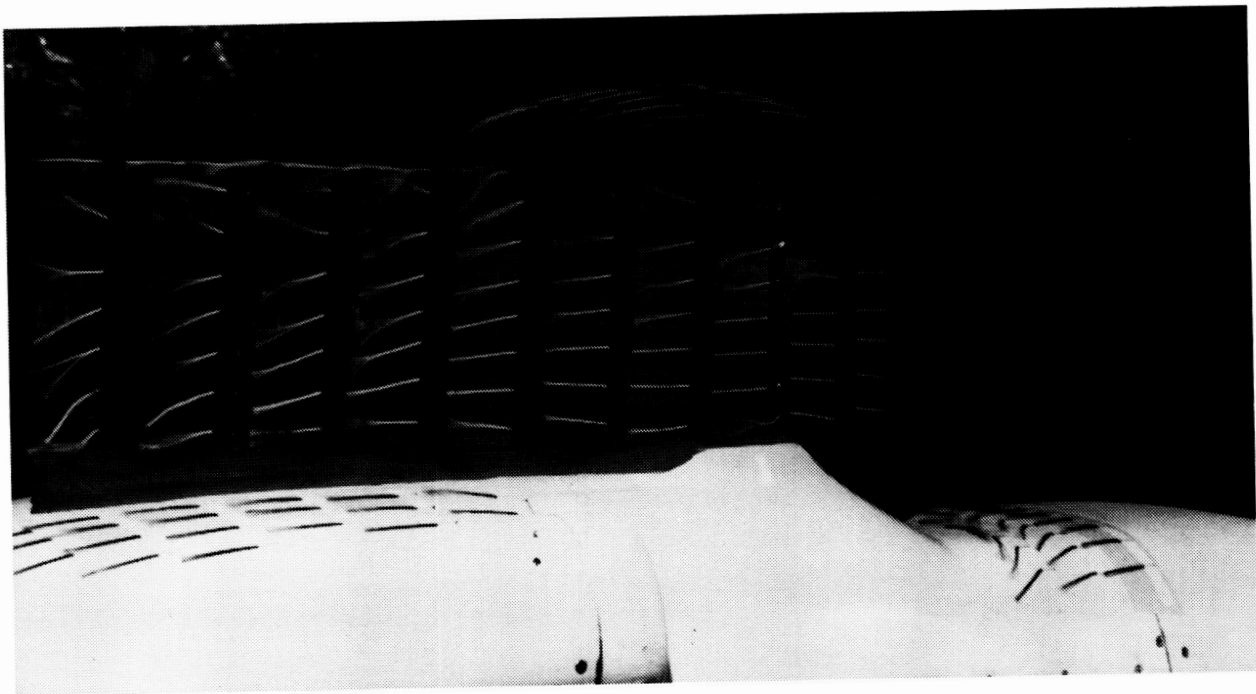

Figure 31.— Tufting flow of configuration H10, S150.



Figure 32.— Tufting flow of configuration H20, S40.

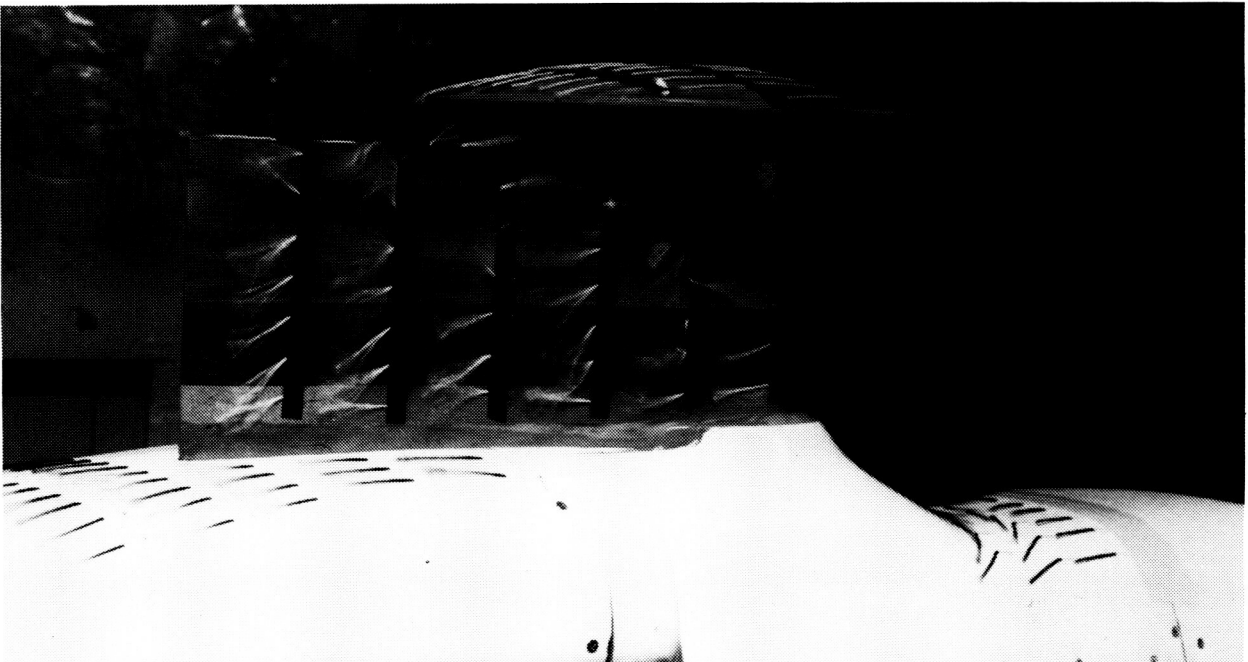

Figure 33.— Tufting flow of configuration H20, S80.

ORIGINAL PAGE IS
OF POOR QUALITY

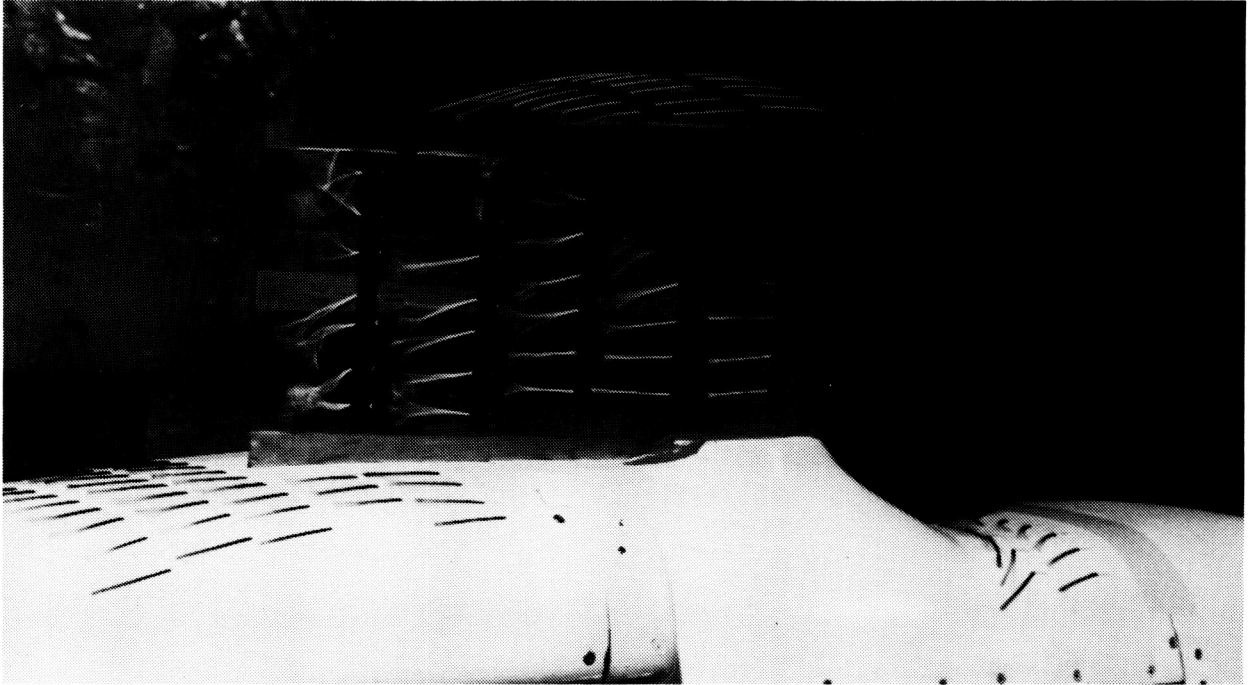

Figure 34.- Tufting flow of configuration H30, S40.

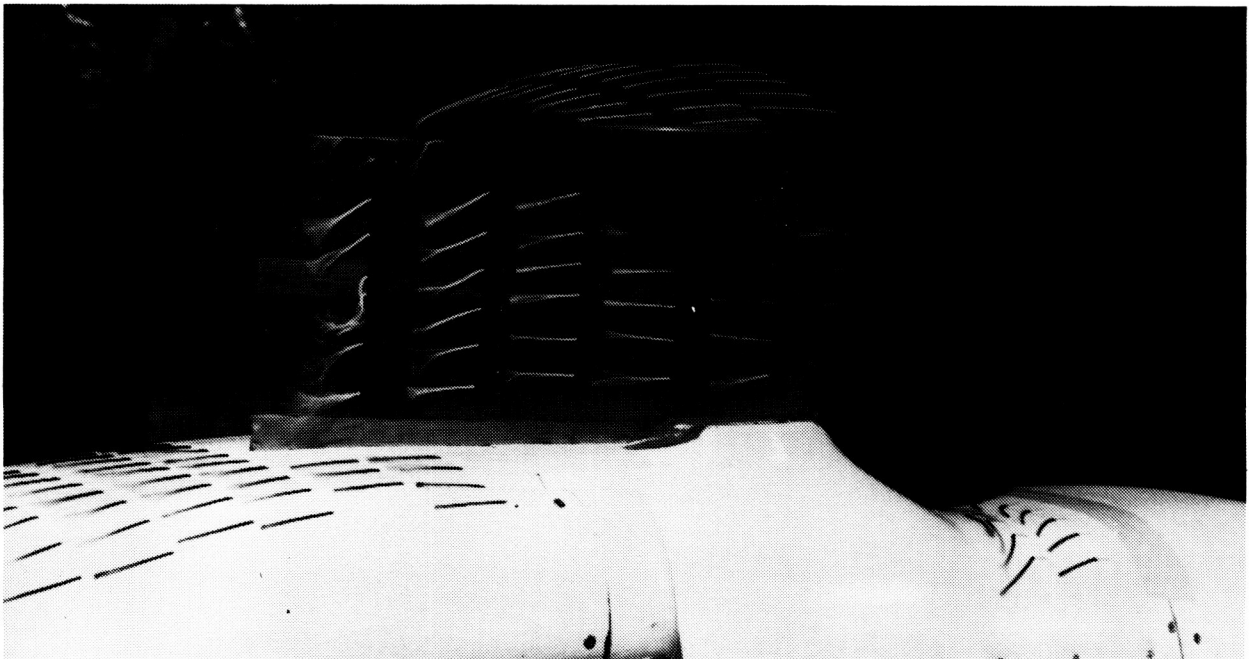

Figure 35.- Tufting flow of configuration H40, S40.



Figure 36.— Tufting flow of configuration H50, S10.

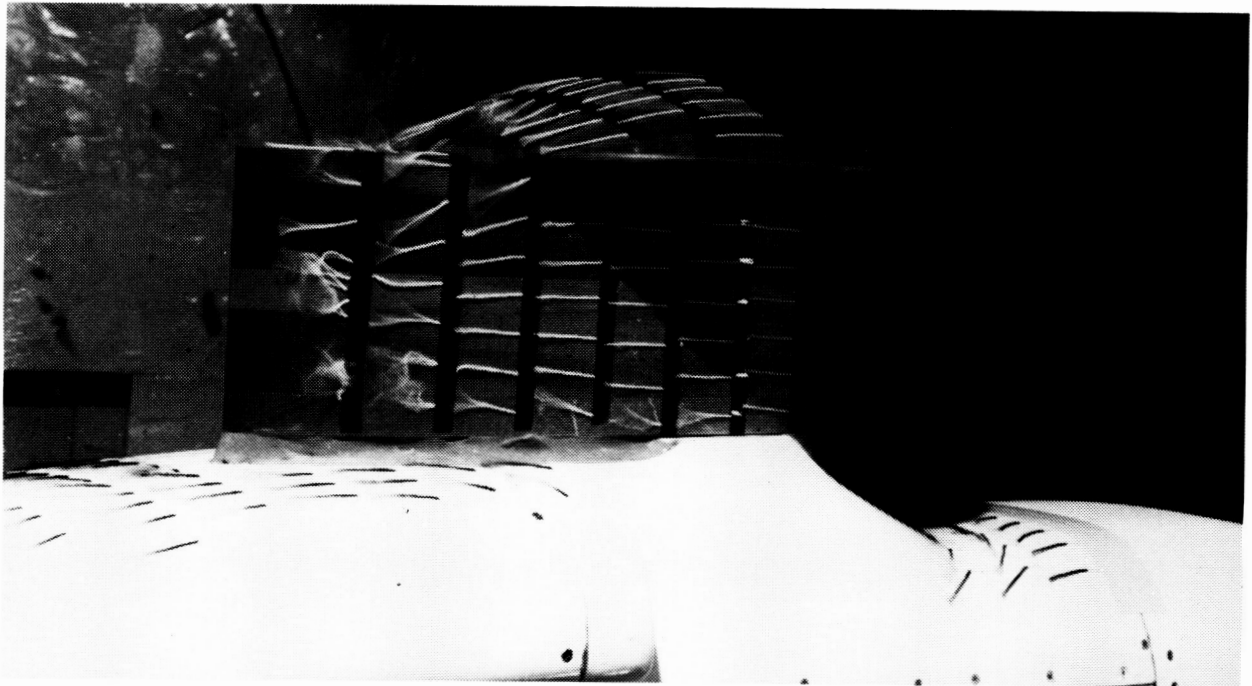

Figure 37.— Tufting flow of configuration H50, S20.

ORIGINAL PAGE IS
OF POOR QUALITY

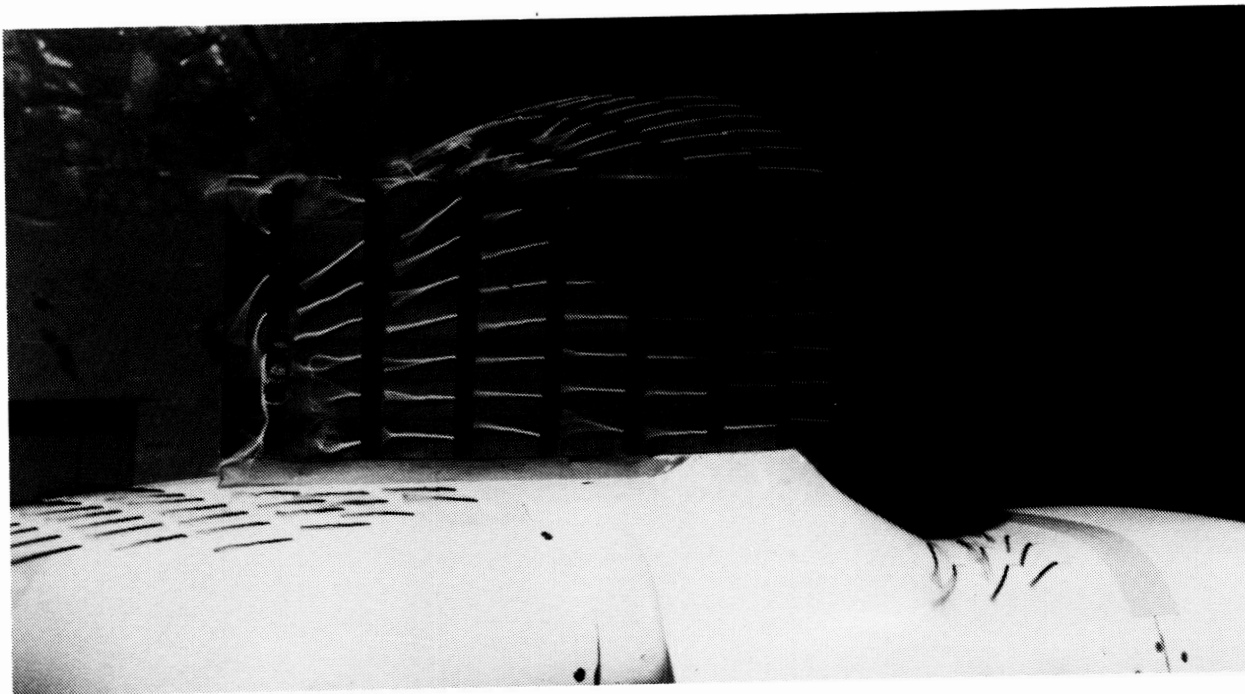

Figure 38.— Tufting flow of configuration H50, S30.

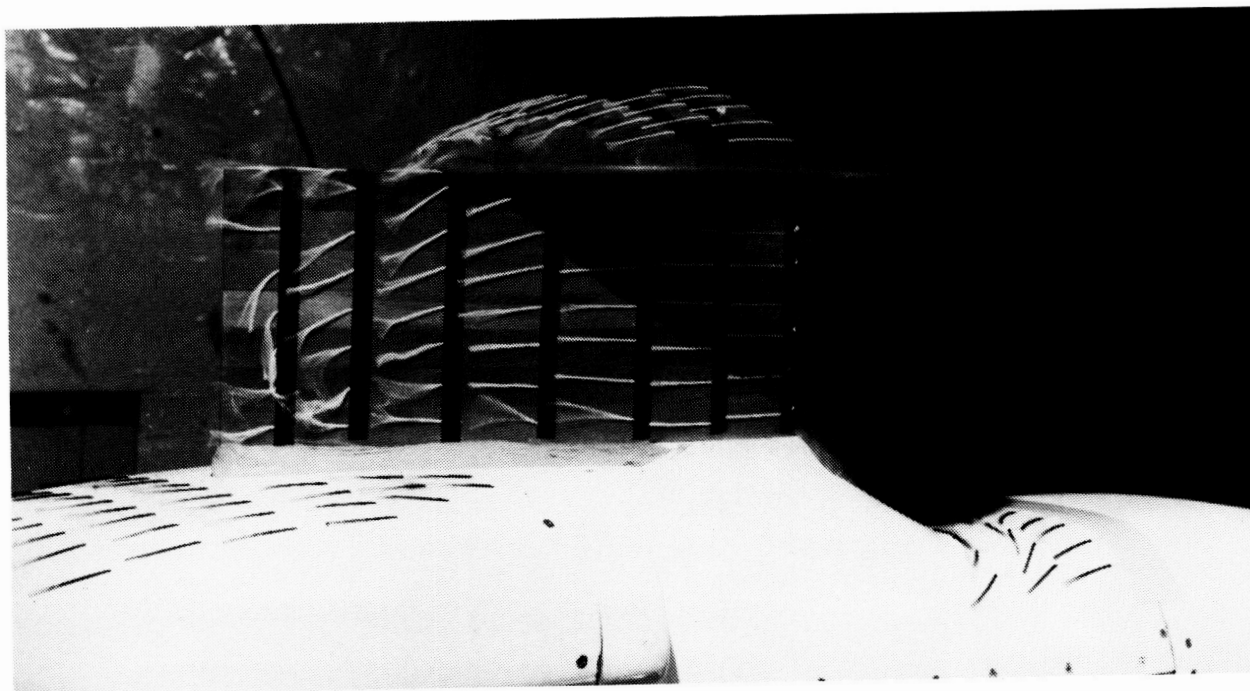

Figure 39.— Tufting flow of configuration H50, S40.

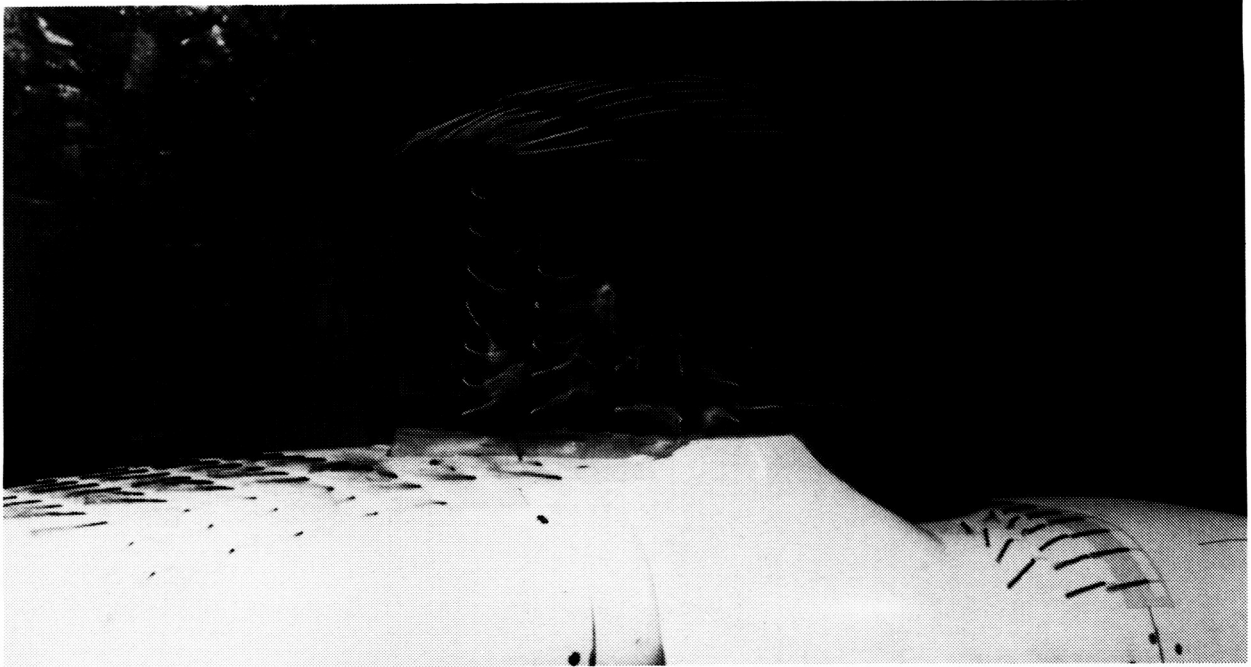

Figure 40.— Tufting flow of configuration H50, S50.



Figure 41.— Tufting flow of configuration H50, S60.

ORIGINAL PAGE IS
OF POOR QUALITY

ORIGINAL PAGE IS
OF POOR QUALITY

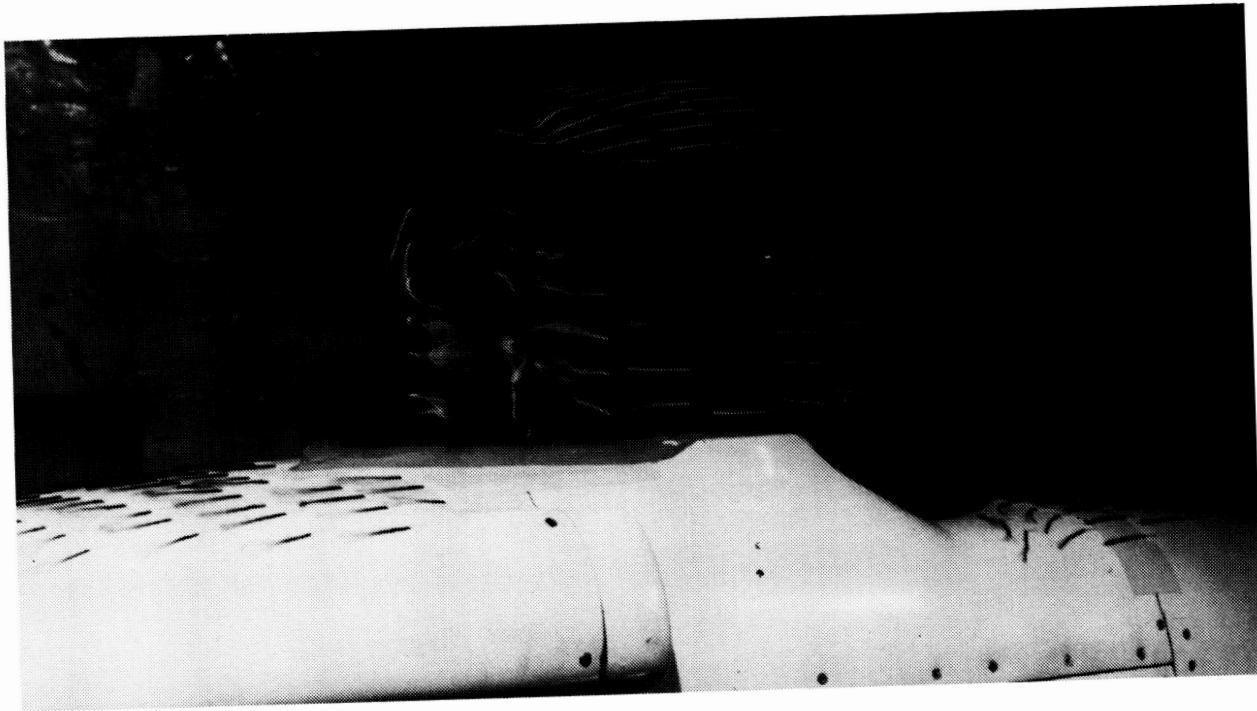

Figure 42.— Tufting flow of configuration H50, S70.

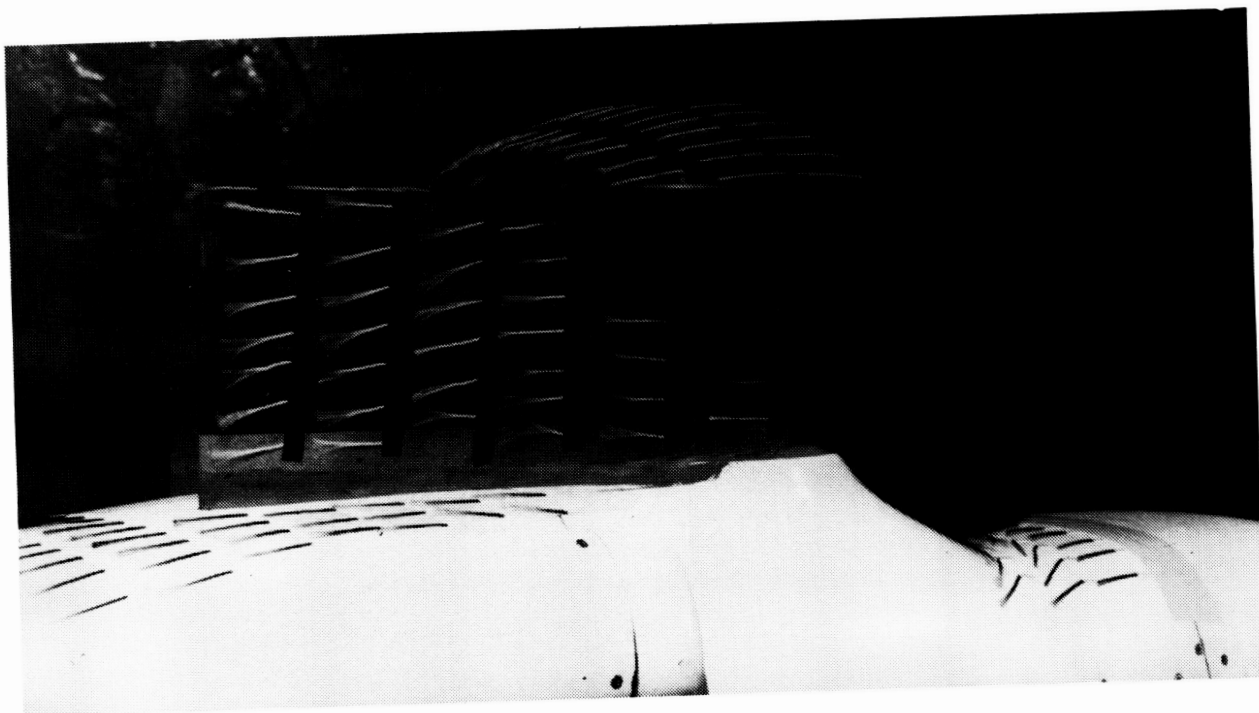

Figure 43.— Tufting flow of configuration H50, S80.

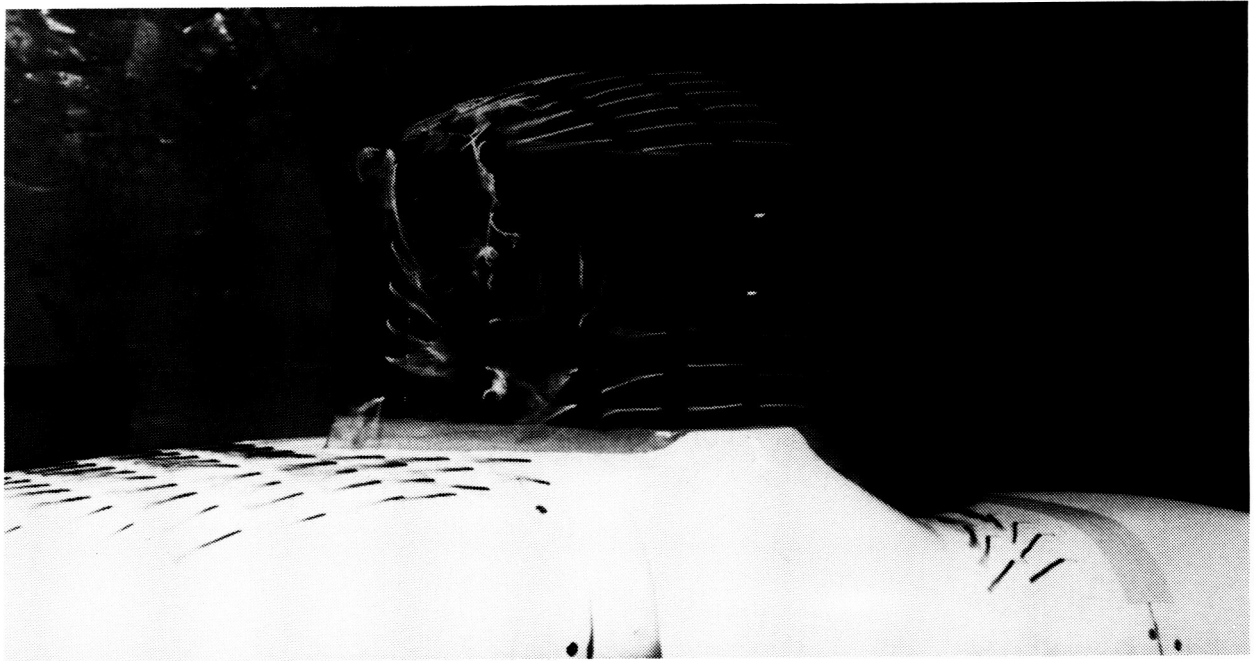

Figure 44.- Tufting flow of configuration H50, S100.

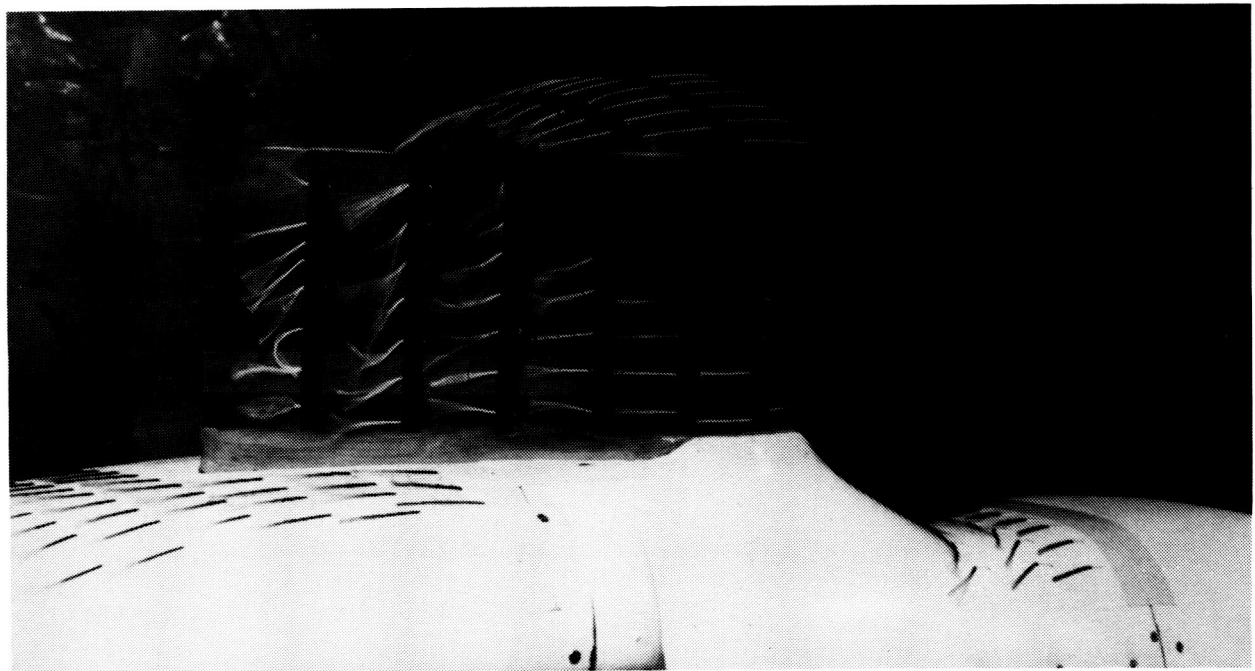

Figure 45.- Tufting flow of configuration H50, S110.

**ORIGINAL PAGE IS
OF POOR QUALITY**

ORIGINAL PAGE IS
OF POOR QUALITY

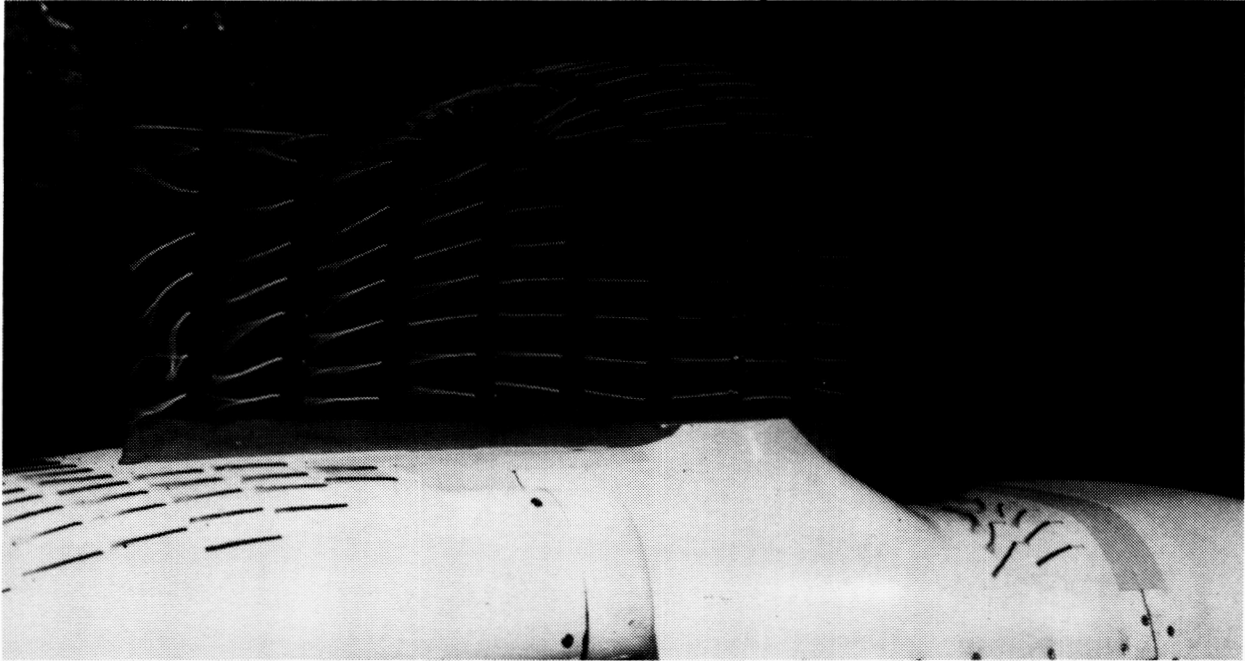

Figure 46.- Tufting flow of configuration H50, S140.

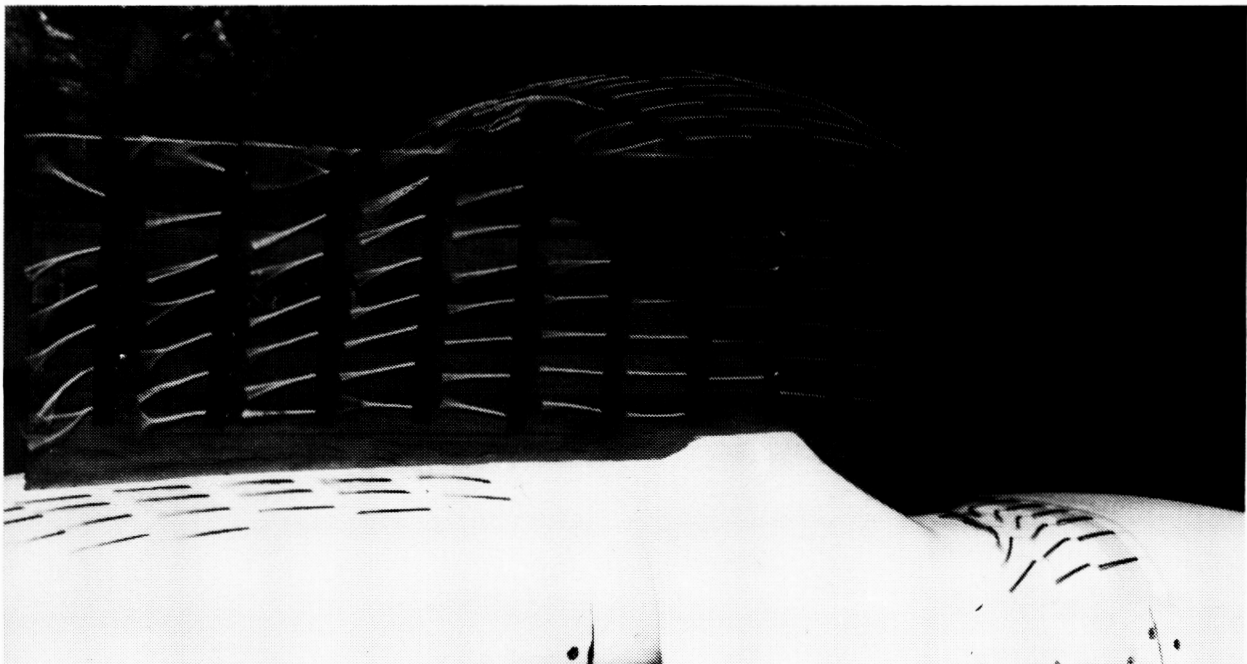

Figure 47.- Tufting flow of configuration H50, S150.

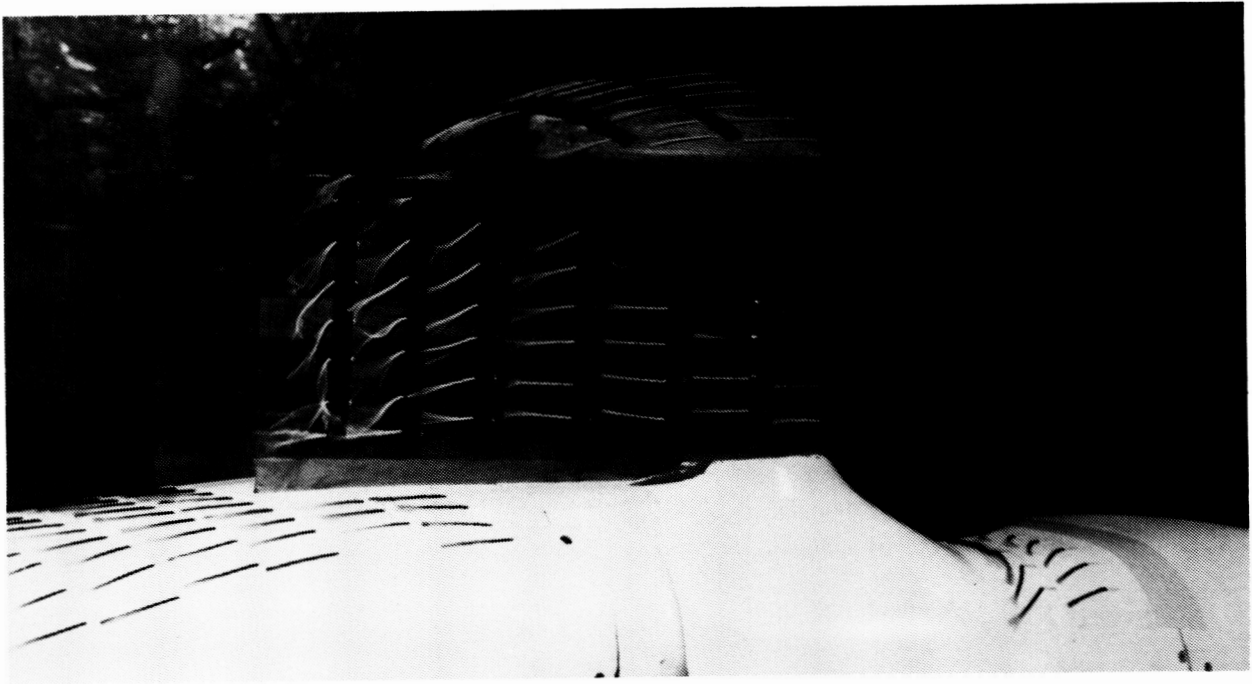

Figure 48.— Tufting flow of configuration H60, S40.

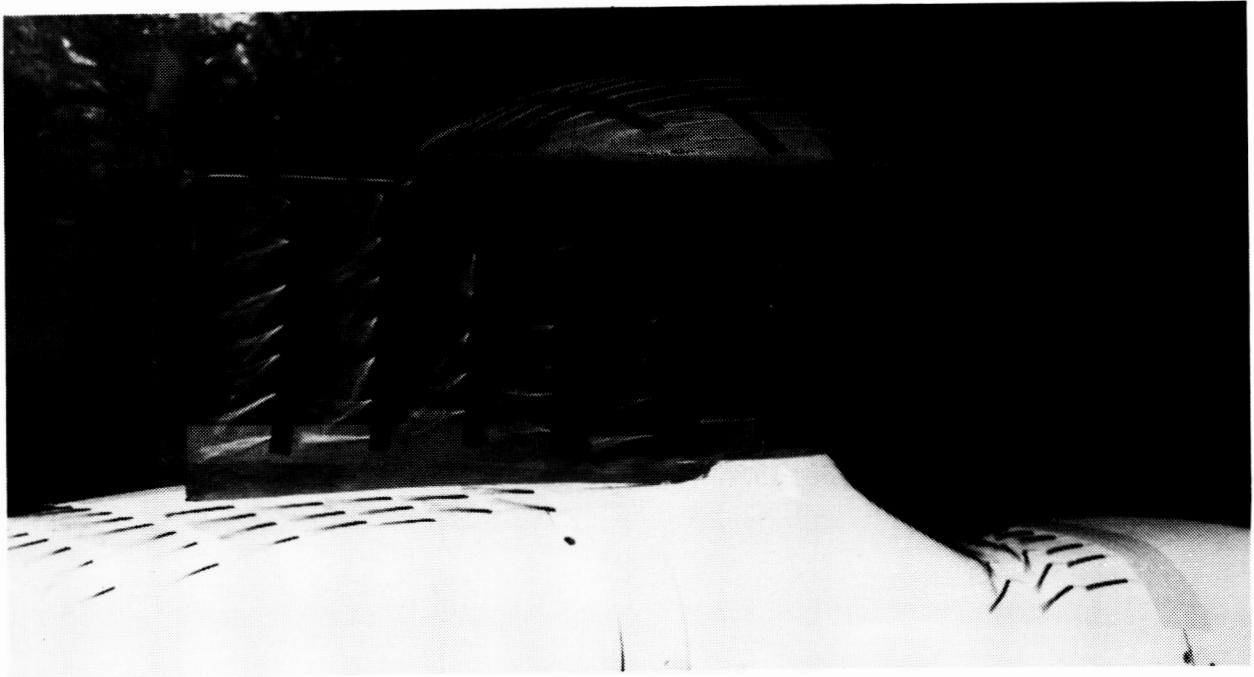

Figure 49.— Tufting flow of configuration H60, S80.

ORIGINAL PAGE IS
OF POOR QUALITY

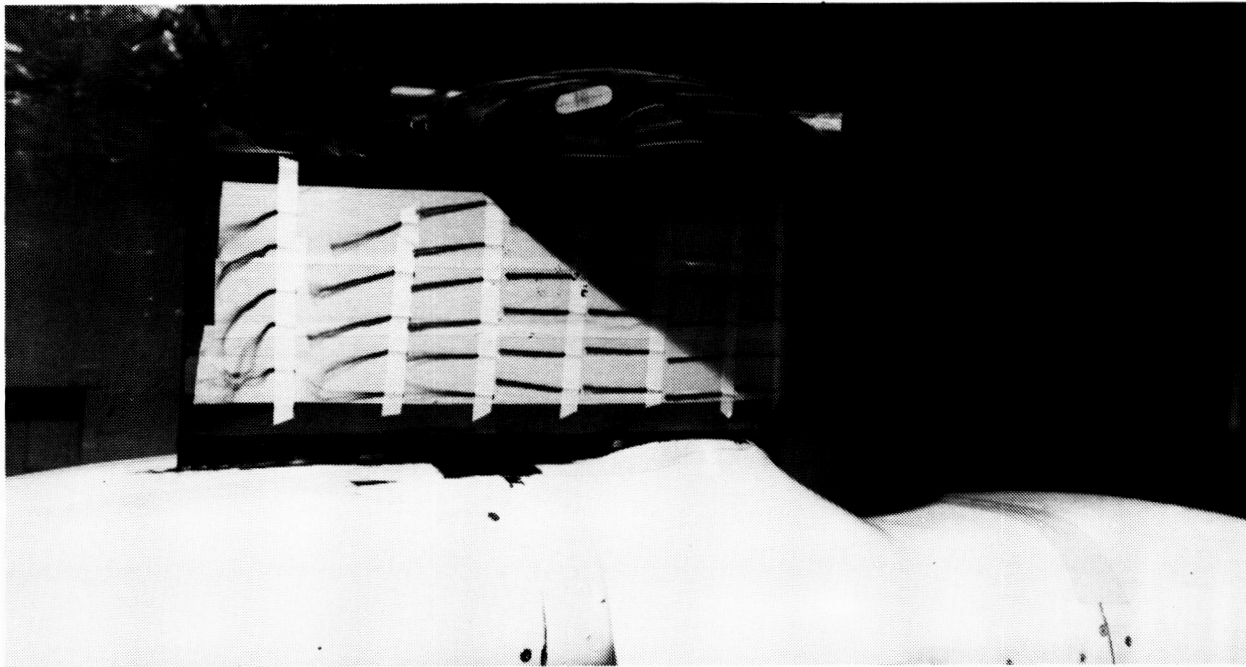

Figure 50.— Tufting flow of configuration H2, S40, $Y = 45^\circ$.

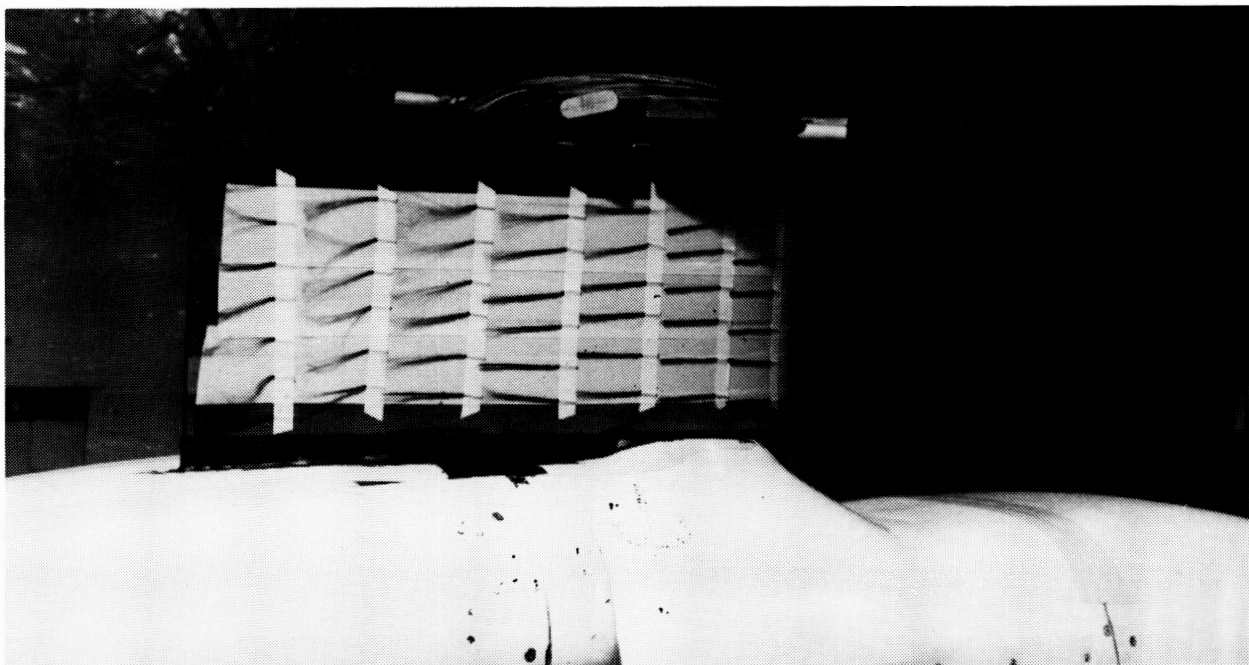

Figure 51.— Tufting flow of configuration H4, S40, $Y = 45^\circ$.

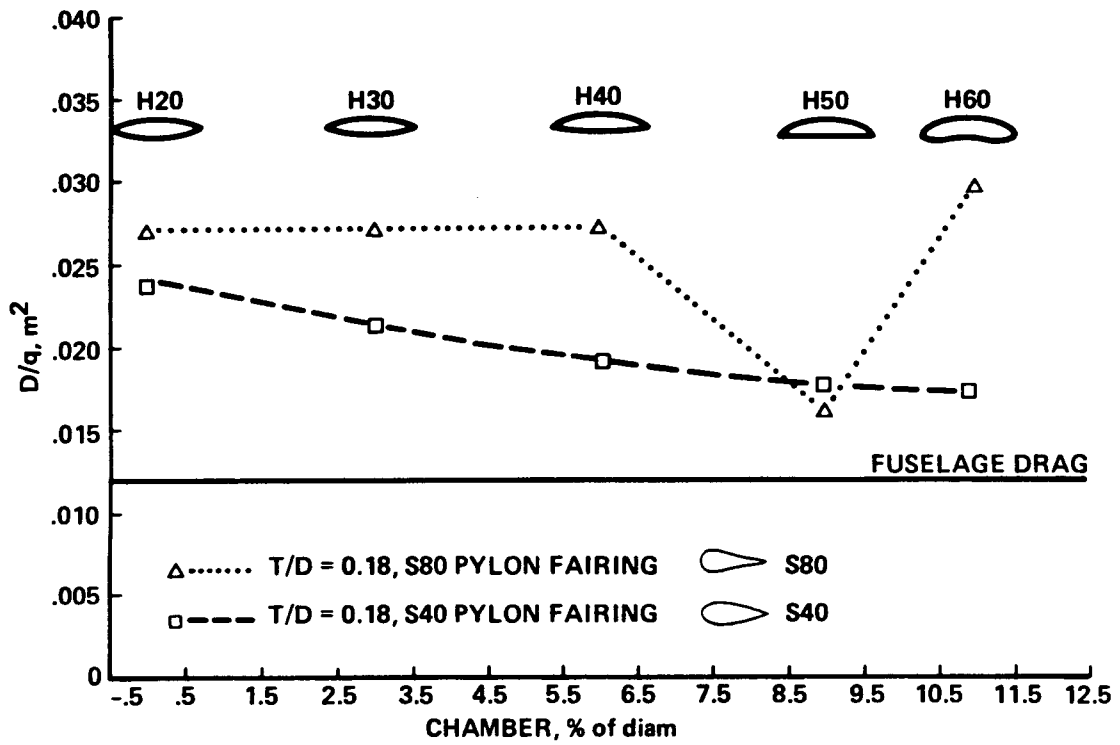

Figure 52.— Hub fairing camber.

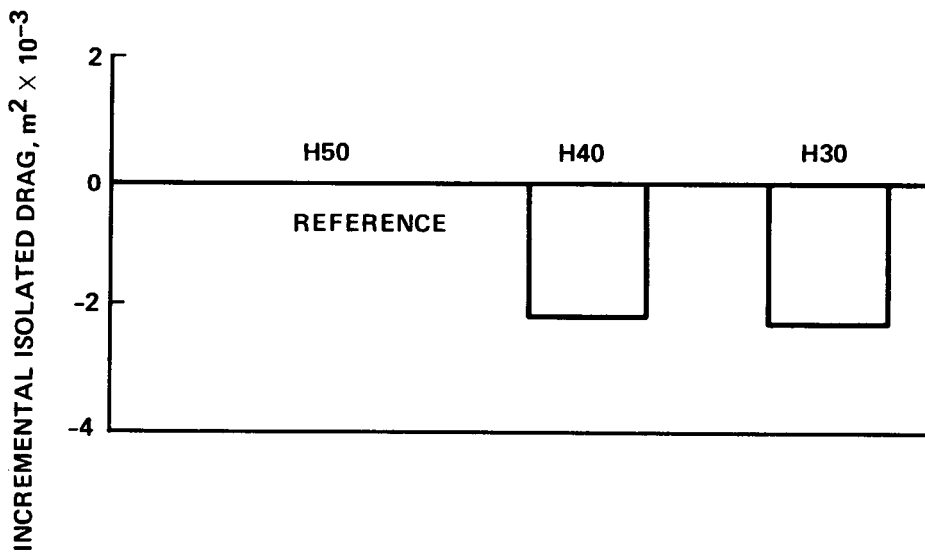
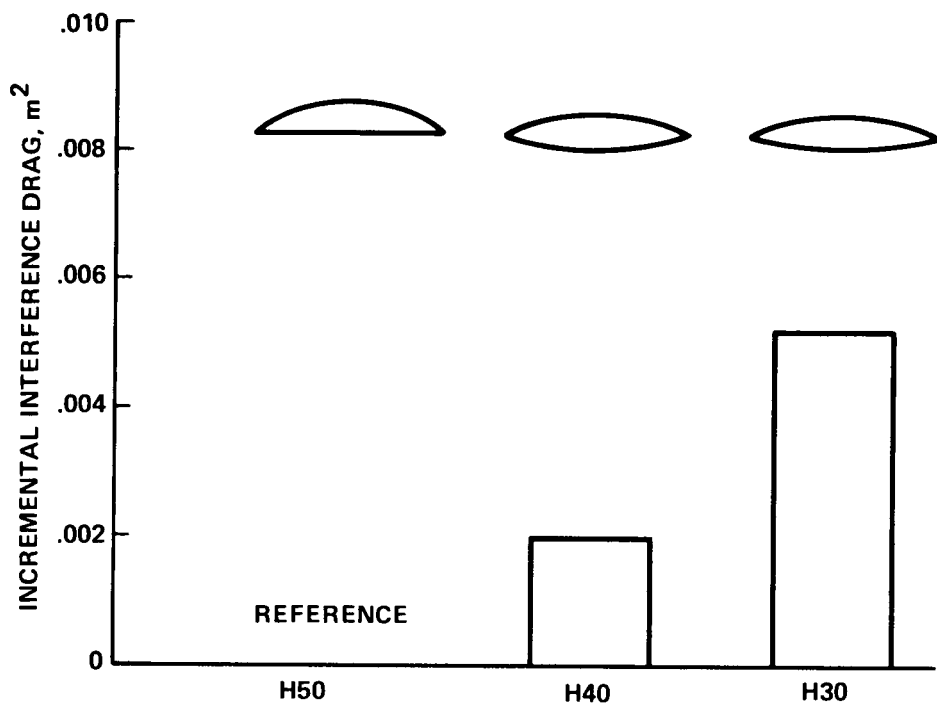

Figure 53.— Effect of cambered hub fairing on interference drag.

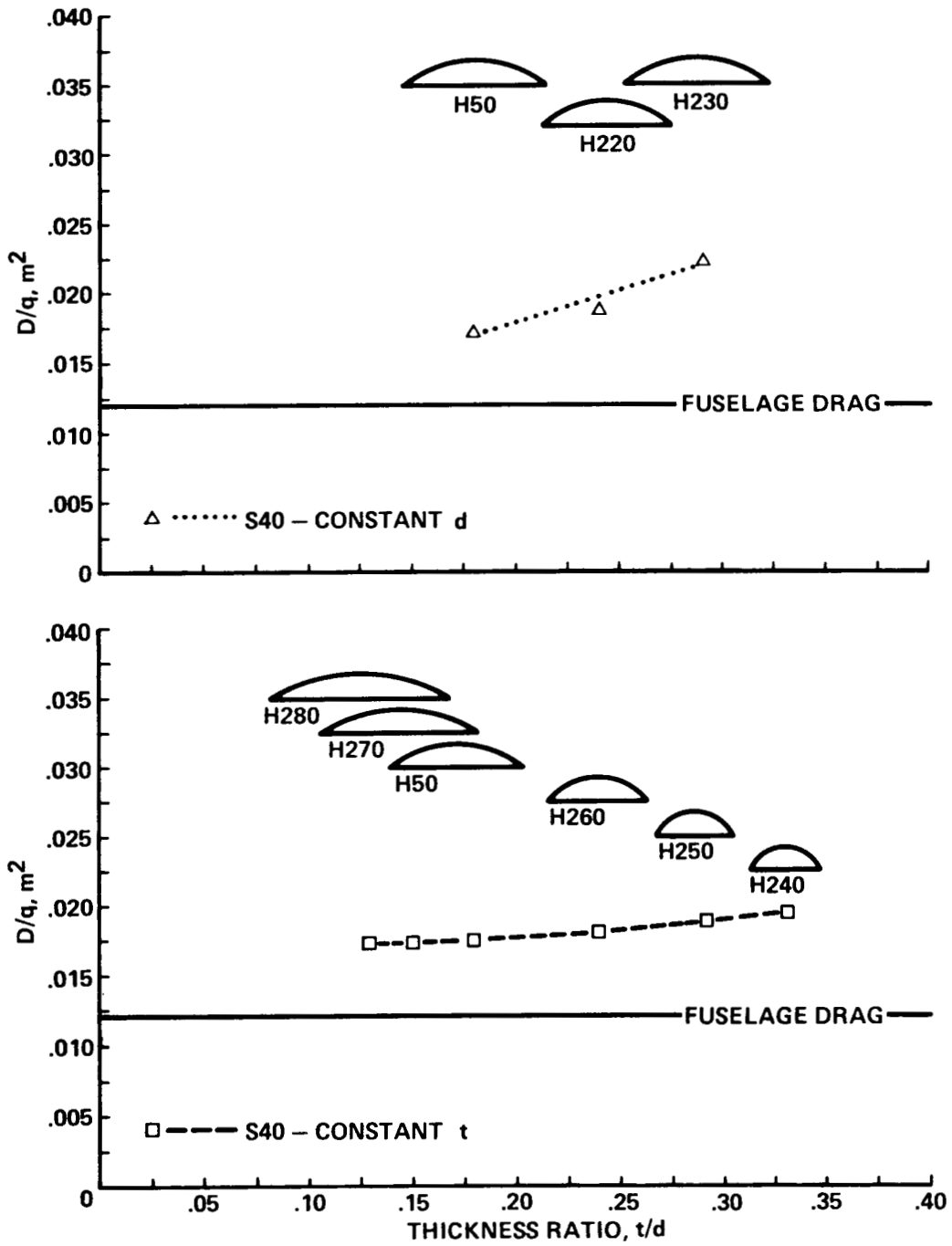
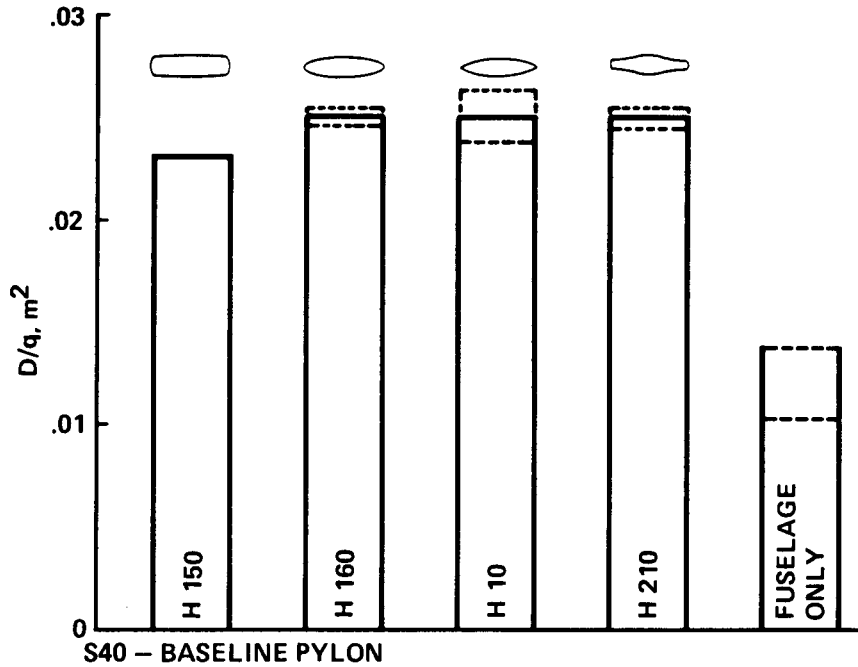
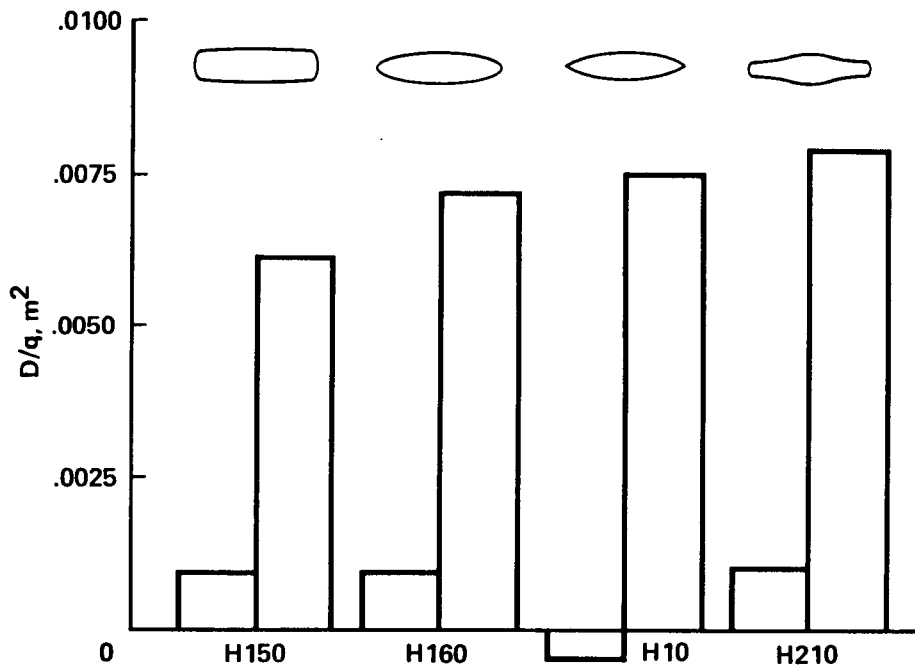

Figure 54.- D/q vs. hub fairing thickness ratio.



NOTE: DASHED LINES REPRESENT HIGH AND LOW VALUES FOR ALL RUNS
 NOTE: SOLID LINE REPRESENTS AVERAGE VALUE FROM ALL RUNS

Figure 55.- D/q as a function of symmetrical hub fairing surface curvature.



BARS ON RIGHT REPRESENT HUB AND INTERFERENCE DRAG
 BARS ON LEFT REPRESENT ISOLATED MODEL RUNS

Figure 56.- Effect of changes in symmetrical hub fairing surface curvature on interference drag.

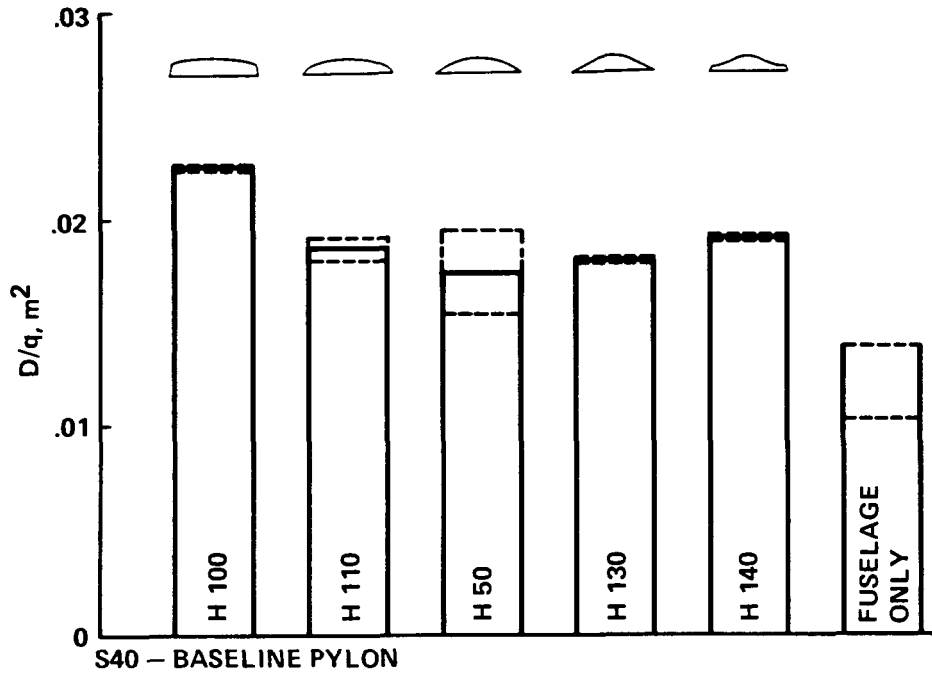

NOTE: DASHED LINES REPRESENT HIGH AND LOW VALUES FOR ALL RUNS
 NOTE: SOLID LINE REPRESENTS AVERAGE VALUE FROM ALL RUNS

Figure 57.- D/q as a function of cambered hub fairing upper surface curvature.

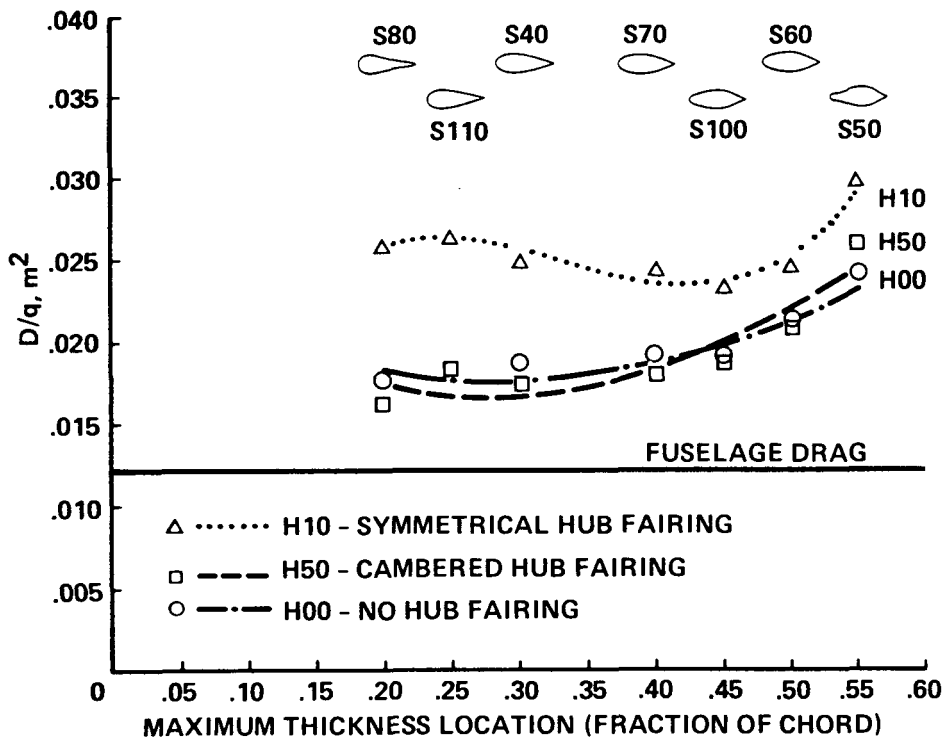

Figure 58.- D/q vs. pylon maximum thickness location.

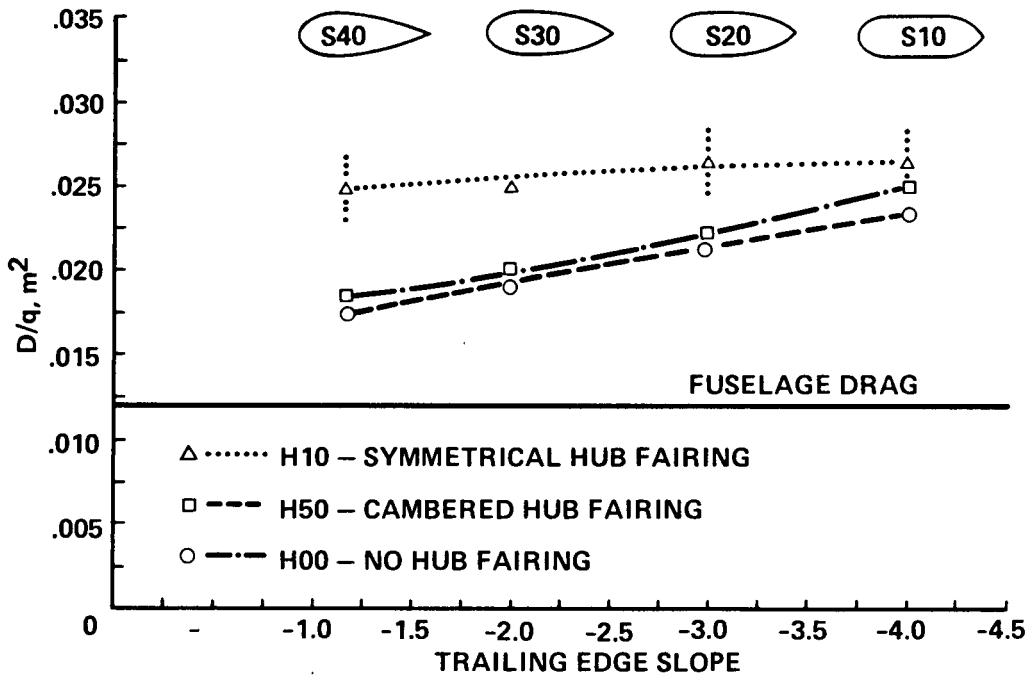

Figure 59.- D/q vs. pylon trailing edge slope.

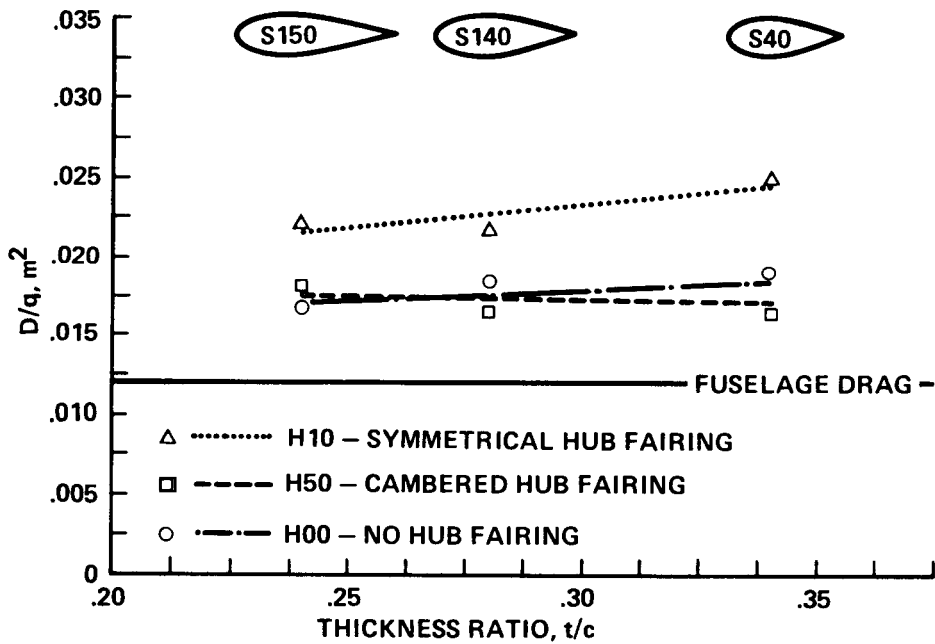

Figure 60.- D/q vs. pylon thickness ratio.

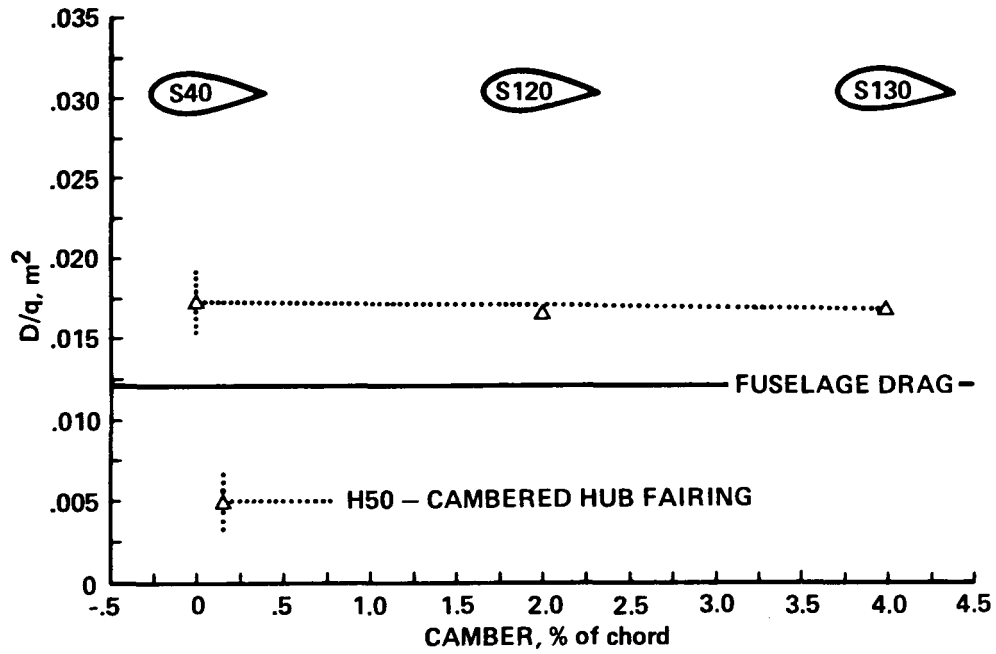

Figure 61.- D/q vs. pylon camber.

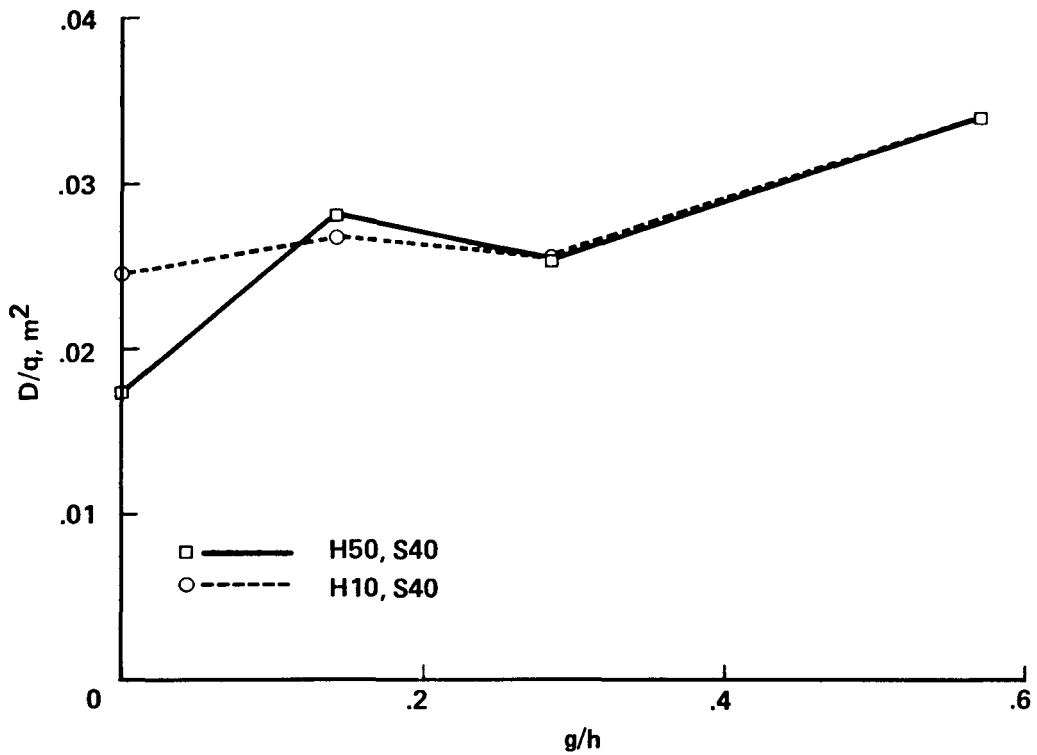

Figure 62.- Effect of hub/pylon gap width on drag (cambered, H50, and symmetrical, H10, fairings with S40 pylon).

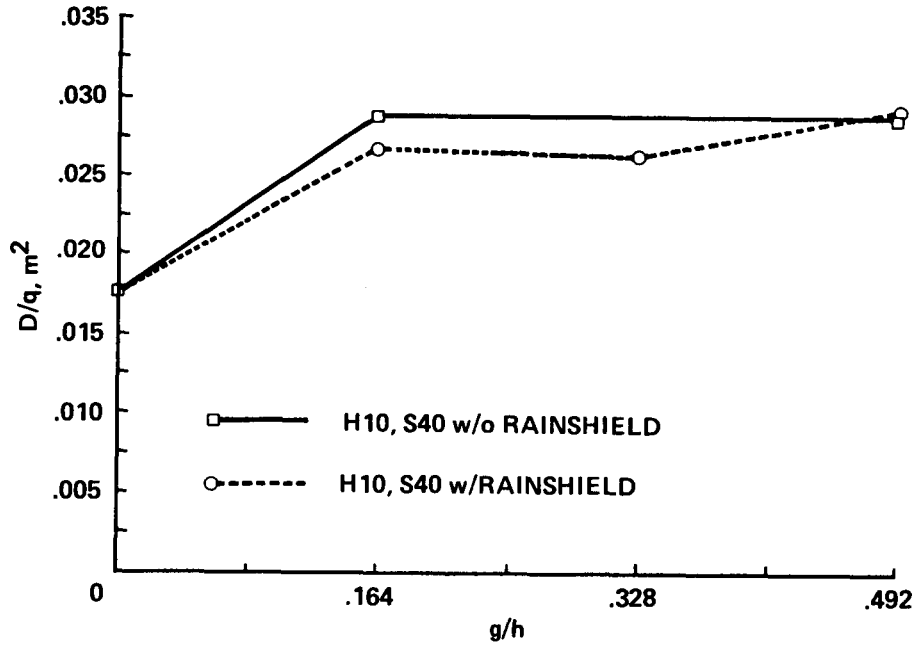

Figure 63.— Effect on D/q of adding a rainshield to configurations with hub/pylon fairing gap (H50, S40).

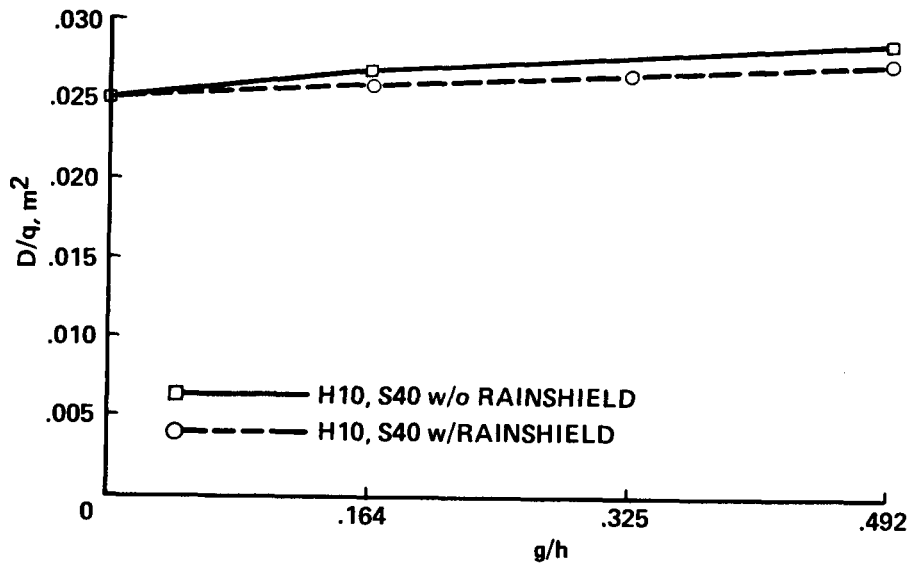

Figure 64.— Effect on D/q of adding a rainshield to configurations with hub/pylon fairing gap (H10, S40).

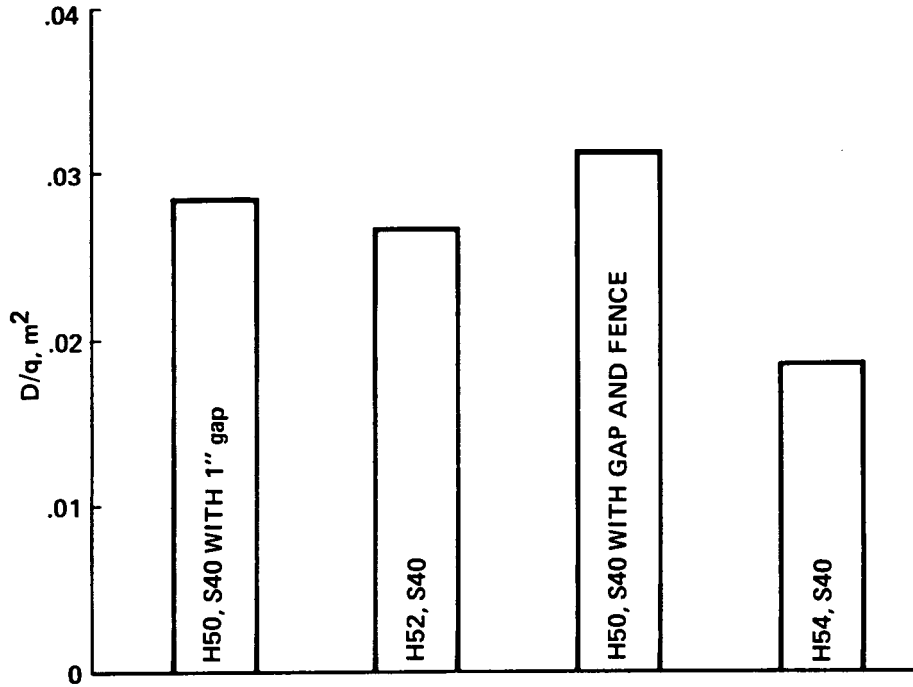
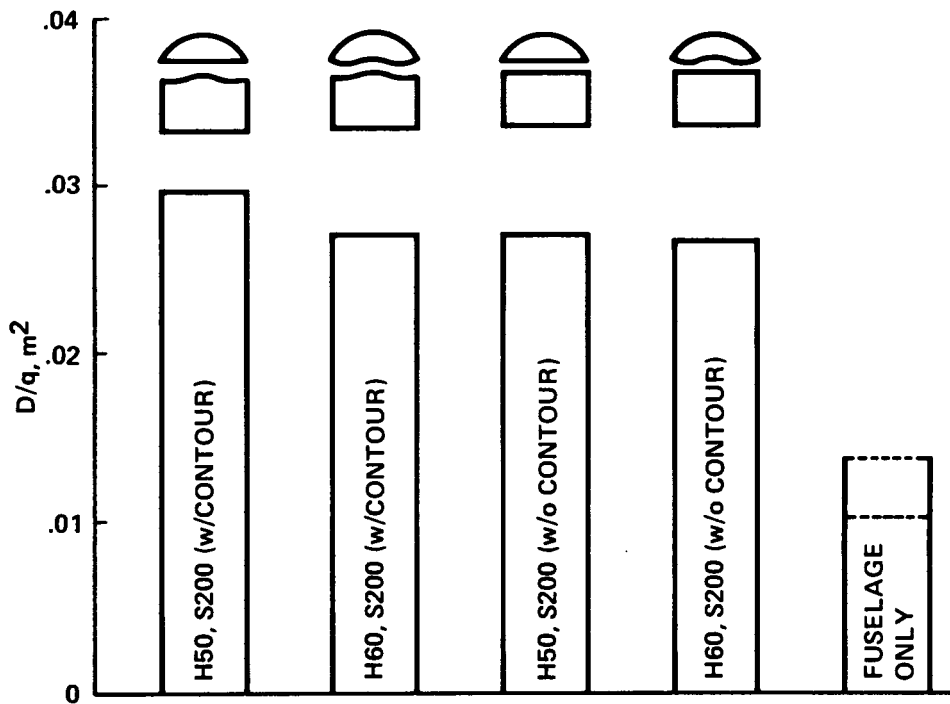
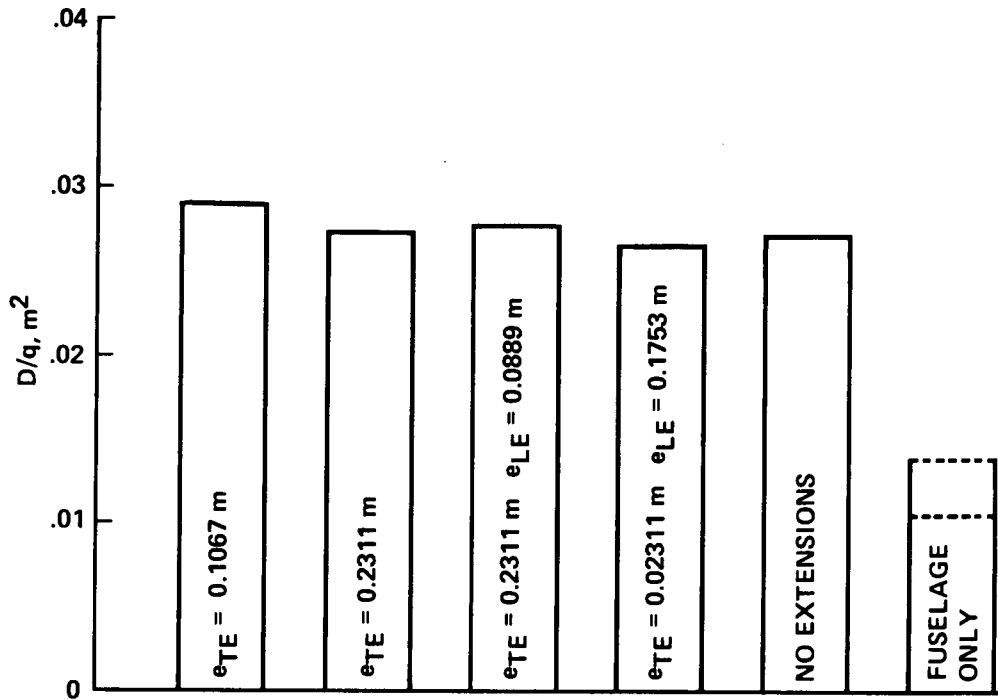

Figure 65.— D/q trends for hub/pylon fairing gap remedies.



NOTE: DASHED LINES REPRESENT HIGH AND LOW VALUES FOR ALL RUNS
 NOTE: SOLID LINE REPRESENTS AVERAGE VALUE FROM ALL RUNS

Figure 66.— Effect on D/q of pylon fairing/hub fairing contour matching.



NOTE: DASHED LINES REPRESENT HIGH AND LOW VALUES FOR ALL RUNS
 NOTE: SOLID LINE REPRESENTS AVERAGE VALUE FROM ALL RUNS

Figure 67.— Effect on D/q of pylon fairing fore and aft extensions.

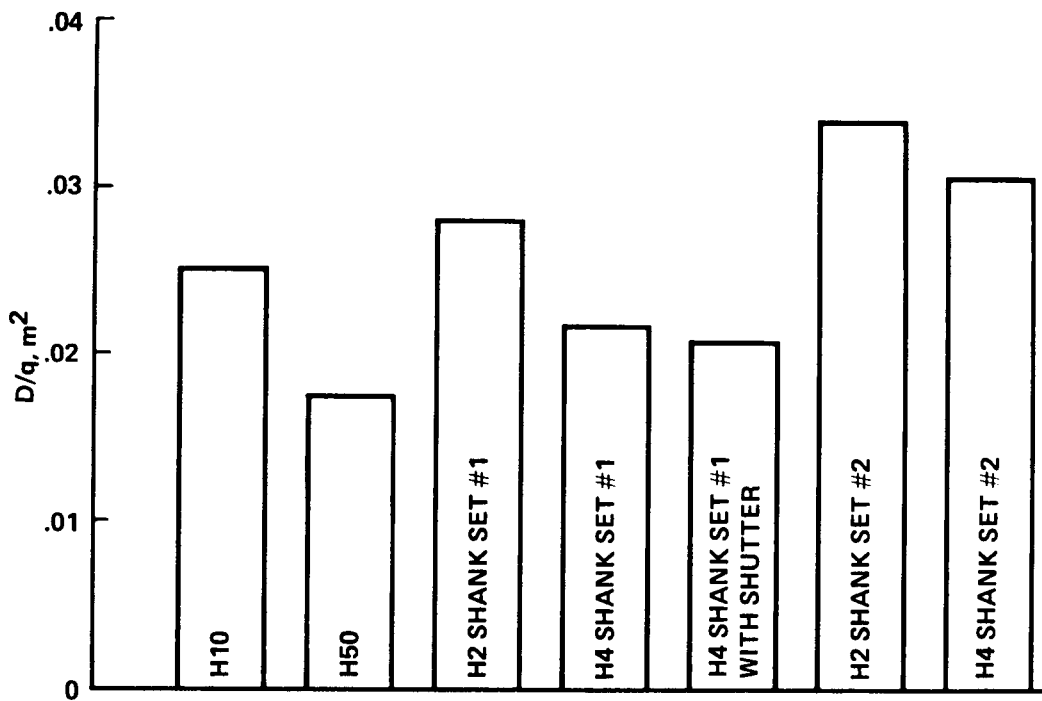

Figure 68.— Effect on D/q of addition of blade shanks to the hub fairing.

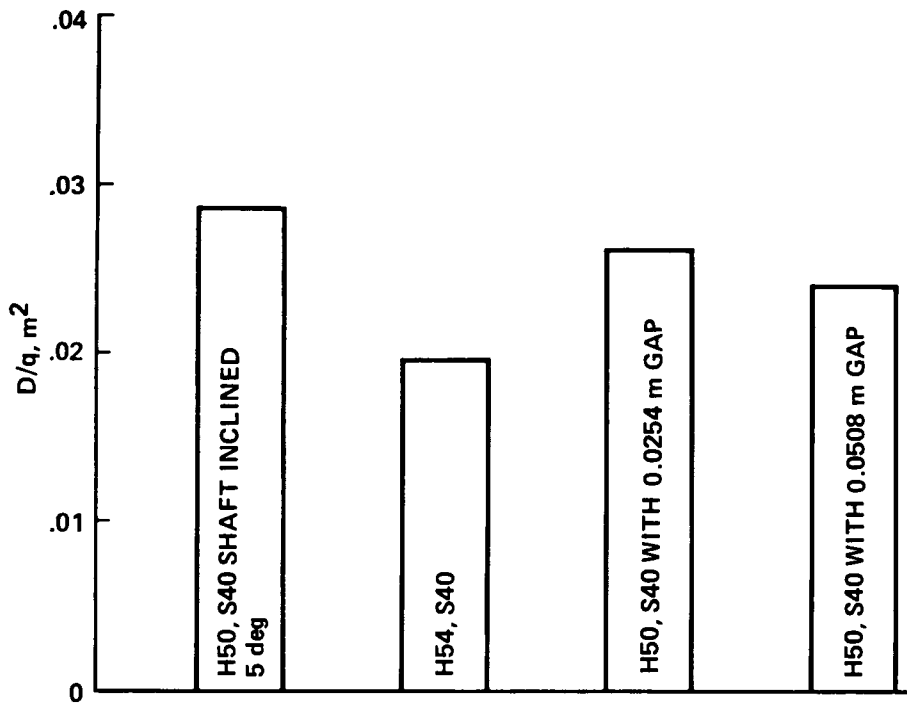

Figure 69.— D/q trends for inclined shaft fairing configurations.

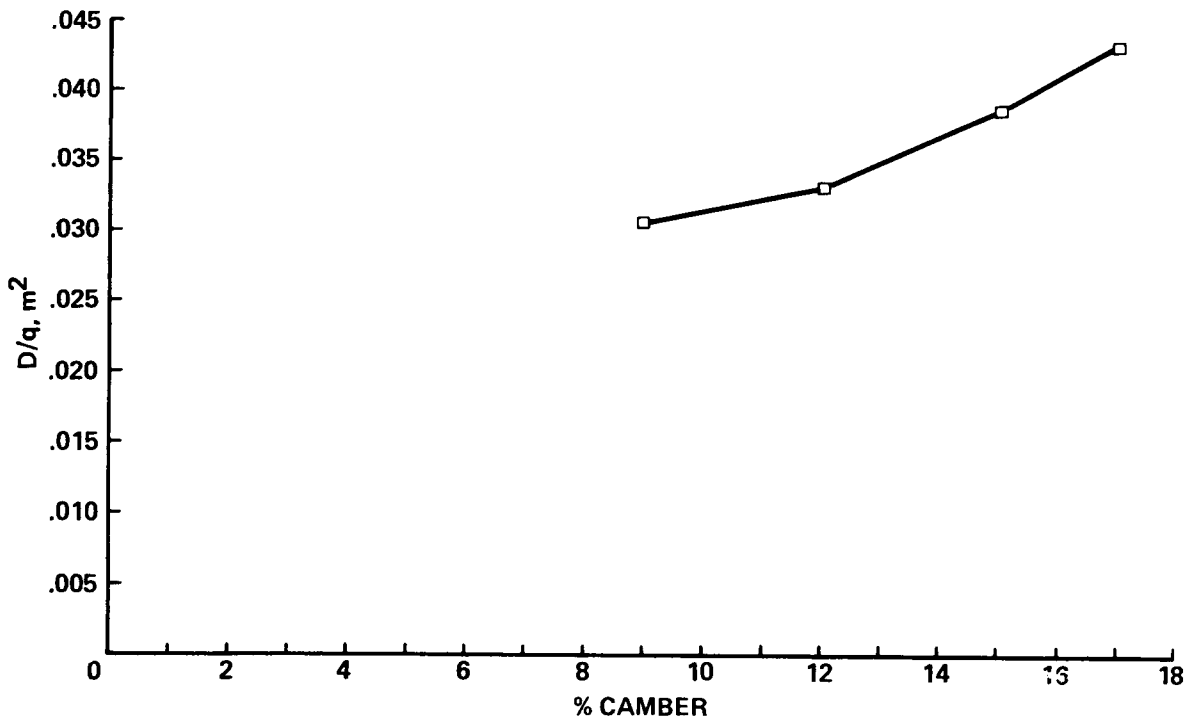
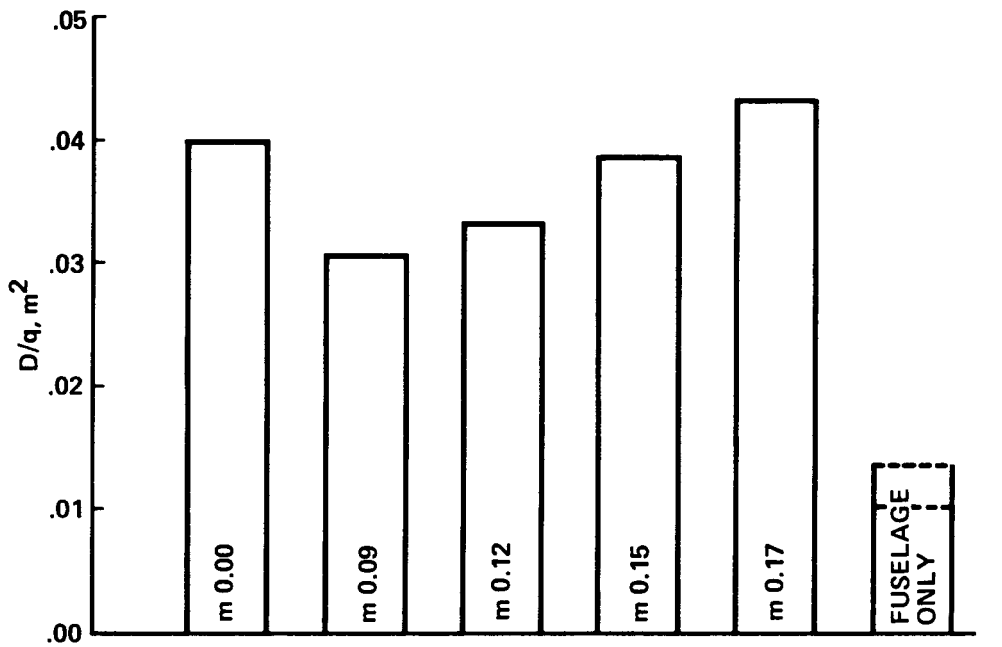

Figure 70.— D/q vs. upper hub fairing camber for coaxial rotor fairing configurations.



NOTE: DASHED LINES REPRESENT HIGH AND LOW VALUES FOR ALL RUNS
 NOTE: SOLID LINE REPRESENTS AVERAGE VALUE FROM ALL RUNS

Figure 71.— D/q for various coaxial rotor fairing configurations.



Report Documentation Page

1. Report No. NASA TM-101052		2. Government Accession No.		3. Recipient's Catalog No.	
4. Title and Subtitle Helicopter Hub Fairing and Pylon Interference Drag			5. Report Date January 1989		
			6. Performing Organization Code		
7. Author(s) D. R. Graham, D. Y. Sung (Sterling Federal Systems, Inc., Palo Alto, CA), L. A. Young, A. W. Louie, and R. H. Stroub			8. Performing Organization Report No. A-89004		
			10. Work Unit No. 505-61-51		
9. Performing Organization Name and Address Ames Research Center Moffett Field, CA 94035-4000			11. Contract or Grant No.		
			13. Type of Report and Period Covered Technical Memorandum		
12. Sponsoring Agency Name and Address National Aeronautics and Space Administration Washington, DC 20546-0001			14. Sponsoring Agency Code		
			15. Supplementary Notes Point of Contact: L. A. Young, Ames Research Center, MS TR-031, Moffett Field, CA 94035-4000 (415) 694-4022 or FTS 464-4022		
16. Abstract <p>A wind tunnel test was conducted to study the aerodynamics of helicopter hub and pylon fairings. The test was conducted in the 7- by 10-Foot Subsonic Wind Tunnel (Number 2) at Ames Research Center using a 1/5-scale XH-59A fuselage model. The primary focus of the test was on the rotor hub fairing and pylon mutual interference drag. Parametric studies of pylon and hub fairing geometry were also conducted. This report presents the major findings of the test as well as tabulated force and moment data, flow visualization photographs, and graphical presentations of the drag data. The test results indicate that substantial drag reduction can be attained through the use of a cambered hub fairing with circular arc upper surface and flat lower surface. Furthermore, a considerable portion of the overall drag reduction is attributed to the reduction in the hub-on-pylon interference drag. It is also observed that the lower surface curvature of the fairing has a strong influence on the hub fairing and on pylon interference drag. However, the drag reduction benefit that was obtained by using the cambered hub fairing with a flat lower surface was adversely affected by the clearance between the hub fairing and the pylon.</p>					
17. Key Words (Suggested by Author(s)) Hub drag Interference Hub fairing Pylon			18. Distribution Statement Unclassified – Unlimited Subject Category – 02		
19. Security Classif. (of this report) Unclassified		20. Security Classif. (of this page) Unclassified		21. No. of pages 190	22. Price A09