

N89-19870

DESIGN CONCEPT  
FOR THE  
FLIGHT TELEROBOTIC SERVICER (FTS)

J. F. Andary, S. W. Hinkal, and J. G. Watzin  
NASA/Goddard Space Flight Center  
Greenbelt, Maryland 20771, U.S.A.

ABSTRACT

NASA has just completed an In-house Phase B Study (one of three studies) for the preliminary definition of a teleoperated robotic device that will be used on the National Space Transportation System (NSTS) and the Space Station to assist the astronauts in the performance of assembly, maintenance, servicing, and inspection tasks.

This device, the Flight Telerobotic Servicer (FTS), will become a permanent element on the Space Station. Although it is primarily a teleoperated device, the FTS is being designed to grow and evolve to higher states of autonomy. Eventually, it will be capable of working from the Orbital Maneuvering Vehicle (OMV) to service free-flying spacecraft at great distances from the Space Station. A version of the FTS could also be resident on the large space platforms that are part of the Space Station Program.

INTRODUCTION

The In-house Phase B Study helped NASA understand operational concepts and scenarios for the FTS. The results will not be used as the design concept for the FTS. Grumman Space Systems in Bethpage, NY, and Martin Marietta, Denver Aerospace in Denver, CO, are conducting more in-depth preliminary design studies.

This paper discusses the technical design drivers that the In-house Phase B Study identified as significant in the development of a robotic system for space. The Phase B Study started with the initial requirements of the top-level mission, system, and functional requirements for the FTS [1]. These requirements were developed during a 2-month Phase A Study conducted by NASA during the fall of 1986 [2 and 3].

The output of the Phase B Study will be integrated with the Martin Marietta and Grumman results to refine the requirements for Phases C and D of the FTS Program that are expected to begin in the spring of 1989.

STUDY APPROACH

The Phase B Study started with a detailed analysis of the Space Station tasks described in the requirements document [1]. These tasks describe generic capabilities that are intended to be representative of the fundamental mission of the

FTS as a robotic device that assists the astronauts in assembly, maintenance, servicing, and inspection tasks in the unpressurized environment of the Space Station.

Analyzing the tasks in the requirements document [1] led to the identification of a number of design drivers for the development of the FTS. These design drivers resulted in a series of trade studies that were used to develop candidate design solutions. The resulting design concept for the FTS was called the "Tinman." This concept resulted in a robotic system that was adequate for the assigned tasks and could perform the tasks reliably and safely.

Advanced technology items were scrutinized as to their relevance to the performance of the assigned tasks as well as their state of readiness. If an item was not considered necessary, it was not incorporated into the design. Some items were considered appropriate, but their state of readiness made them too high a risk for inclusion into the initial implementation of the FTS. High-technology should not be used just for the sake of using it, then to have it fail in orbit. An early failure of the FTS would be a great setback for space robotics. Instead of being a useful tool for the astronauts, the FTS would be discarded and the astronauts would turn to another means of accomplishing the tasks.

A program requirement is that the FTS must be capable of growth and evolution. System adaptability is necessary because of the emerging technologies that will be valuable to the program once they have matured. The FTS must be designed from the ground up with the proper "hooks" and "scars" for growth. With the appropriate systems engineering and architectures that can accommodate growth, advanced technology with software and hardware can be added later to the system with minimum impact. To accomplish this, NASA has adopted a control architecture developed by the National Bureau of Standards (NBS) that permits this type of growth [4].

DESIGN CONCEPT

Figure 1 shows the design concept that was developed for the FTS during the Phase B Study. As shown in the drawing, the telerobot is composed of three major subassemblies: the main body, the manipulator arm assembly, and the arm positioning system.

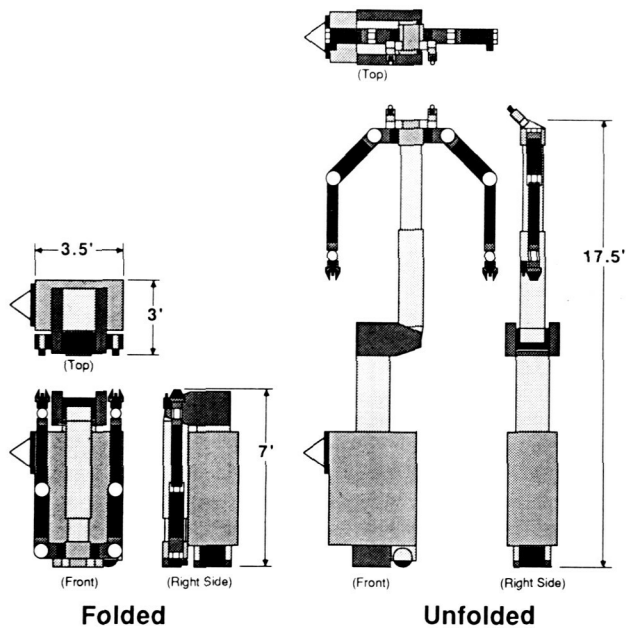

Figure 1. FTS Dimensions

The main body contains all the major electronic components of the telerobot, as well as the grapple fixture by which the telerobot is picked up by one of the large manipulator arms (e.g., the Space Station Remote Manipulator System (SSRMS) or the NSTS Remote Manipulator System (RMS)). The main body also contains the attachment grapple (or foot) by which the telerobot is securely fixed at the worksite.

One of the features of the main body of the telerobot is that it is free to rotate about its central core and the attachment foot. This freedom to rotate allows the thermal radiators, that cover three sides of the main body, to be oriented for optimum heat rejection at the worksite. Main body rotation with respect to the attachment foot allows the operator of the large manipulator arm (SSRMS or RMS) another degree of freedom to help orient the FTS foot for proper mating to the worksite attachment point.

The next major component of the telerobot is the arm positioning system that consists of two, linearly driven, tubular sections connected through an offset rotational joint. The lower section is free to rotate simultaneously with respect to both the main body and the attachment foot. The manipulator arms are free to rotate  $\pm 180$  degrees with respect to the upper section. Five degrees of freedom are obtained to position the arms relative to the telerobot main body and attachment location. There are a number of advantages to the arm positioning system: it extends the reach of the telerobot without extending the length of the manipulator arms; it allows the arms to be positioned squarely to a task so that the teleoperator interfaces with the task in a natural manner; and it allows the telerobot to reach out over large objects which may come between the attachment fixture and the location of the task.

The final component of the telerobot is the manipulator arm assembly that is mounted to the end of the positioning system. It consists of the shoulder assembly that rotates

$\pm 180$  degrees about the end of the positioning system, and two, 7-degree of freedom manipulators mounted to each end of the shoulder assembly. The manipulators are 1.524 meters (60 inches) long and are configured with a roll-pitch-roll shoulder, pitch in the elbow, and roll-pitch-roll in the wrist.

In addition to the telerobot, the FTS includes two workstation designs: a stowable workstation for the NSTS that is mounted in the aft flight deck of the shuttle and the Space Station workstation that will include FTS unique hardware that will be incorporated into the Space Station Multipurpose Application Console (MPAC).

## DESIGN DRIVERS

During the analysis of the requirements and task capabilities, the study team identified the following major design drivers for the FTS:

- Thermal Environment
- Independent Operation
- Manipulator Stability and Positioning
- Safety
- Mobility
- Evolution
- One-G Operation
- Human Interface

The impact of each of these design drivers on the final design concept will be discussed in the following paragraphs. Not all of the design drivers are independent. Often, more than one of the drivers affects the design of a particular subsystem therefore a systems approach had to be taken to the trade studies in order to determine the appropriate solution leading to the best overall design concept.

### Thermal Environment

The thermal environment created by the vacuum of space introduces unique problems for the FTS in an area that is only a minor concern for terrestrial robots. In space, the only way of dissipating heat is by radiation or conduction. The only paths for conduction were by hookup to the Space Station thermal system or by dumping heat into the FTS base mounting structure. Both options were considered too restrictive for the flexibility and usefulness of the FTS and they also created a thermal interface to the Space Station that the design team wanted to avoid. Therefore, radiation was the only means of heat dissipation.

Radiating heat from a robot with peak operating power in the 1 to 2 kW range with approximately 20 motors, several high-speed computers, video equipment, and batteries with heat dissipation as the only means of cooling resulted in a thermal problem. The operation of the FTS should not be restricted because of the thermal environment. This meant that the FTS had to be capable of operating with arbitrary

sun angles and with partial blockages from the structure at the worksite.

To overcome these problems, the overall power of the telerobot was reduced, its total radiating capability was increased, and the main battery was removed from the telerobot.

One effect of reducing the power was the selection of motors at each joint that were sized for the tasks in zero gravity but could not operate without assistance on Earth. By using smaller motors, the manipulator thermal system could be separated from the rest of the body and it could collect all the other heat dissipating components into one structure that could be optimized for thermal radiation.

Figure 2 shows the concept for the telerobot body that uses heat pipes to direct the heat from the electronic boxes out to the outside surfaces where radiators cover three sides. The main body was designed to rotate independent of the manipulators and the arm positioning system so that it could be controlled to track an optimal orientation to cold space as the telerobot is performing its tasks.

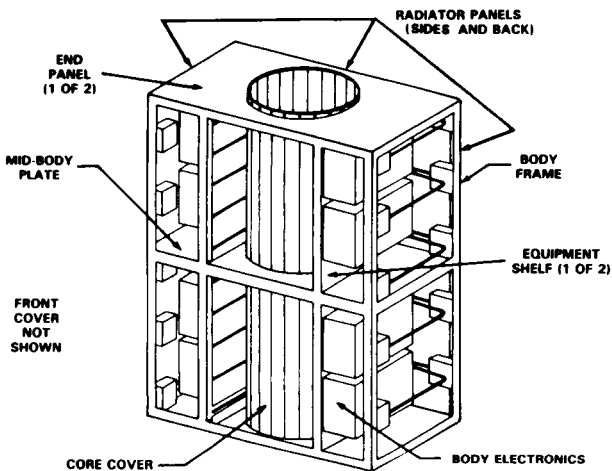

Figure 2. Structure Subsystem Tinman Design

Removing the main battery from the telerobot had a number of effects on the design. It reduced the mass of the telerobot and removed a source of power dissipation. It also freed the telerobot from the tight thermal limits that the battery imposed on the system.

The combined effect of all these design choices produced a thermal design that is independent of the Space Station that will permit indefinite operation of FTS under most conditions. In some extreme cases of radiator blockage, the task may have to be halted temporarily to allow the telerobot to cool down. The use of a small "backpack" was considered composed of Phase Change Material (PCM) that could be used to absorb peak loads to enable the telerobot to continue operating for a brief time under extreme conditions. The thermal system is also an ideal candidate for the incorporation of an expert system that could continually monitor

the thermal health of the telerobot and inform the operator how much time is left before a cool-down period would be required.

#### Independent Operation

Another requirement is that the FTS must be capable of limited operation independent of hard-wired utilities for power, data, and video from the Space Station. As a result of this requirement, a large battery and an RF communications system was included in the design of the FTS. The FTS can never be totally independent of the Space Station because it always needs a firm structural attachment when working. However, the requirement for independent operation gives the FTS a tremendous amount of flexibility allowing it to work in areas on the Space Station where no utility ports are located.

A battery that would allow operation for even a few hours at the power levels of the FTS adds considerable weight and adversely impacts the thermal subsystem. Since the independent operation is not the primary mode of operation, it was decided to remove the battery and the communications system from the main body of the telerobot and locate them in a separate module called the Robot Support Module (RSM). Because there is not a requirement for an early independent operational capability, the RSM could be launched later than the FTS thereby reducing the initial manifested weight of the FTS.

Another advantage of the separate RSM is that it would be possible to design different RSMs for the different operating environments of the FTS. The NSTS and the Space Station have different power and communications systems, therefore a different RSM could be designed for each location. Another RSM could be built for operation from the Orbital Maneuvering Vehicle (OMV) for the servicing of free-flying spacecraft away from the NSTS orbiter or the Station as shown in Figure 3. Two RSMs on the Space Station itself are a possibility so that while one is being used, the other could be having its battery recharged.

#### Manipulator Positioning and Stability

When the work environment of the FTS is examined in both the shuttle payload bay and on the Space Station, the same dimension of 5 meters keeps reoccurring. The shuttle payload bay is 4.57 meters wide and, consequently, most payloads launched by the shuttle are also approximately 5 meters wide or 5 meters in diameter. The SS truss bays are 5-meter cubes and the Attached Payload Accommodation Equipment (APAE) sit on a 5- by 5-meter base. It can be concluded from this information that the ideal reach envelope of the telerobot would be 5-meters. If the telerobot is to work in these locations, it must be able to cover these types of distances. However, early analysis indicated that a 5-meter reach for the manipulator arms was not feasible if the telerobot was to do any dexterous manipulation. A local mobility system and an arm positioning system was chosen to deliver the arms to the task. This approach allows the arms to be shorter and more rigid for the fine control tasks.

Figure 4 shows the reach envelope of the telerobot. Situated in the center of the Space Station truss bay, the telerobot

ORIGINAL PAGE IS  
OF POOR QUALITY

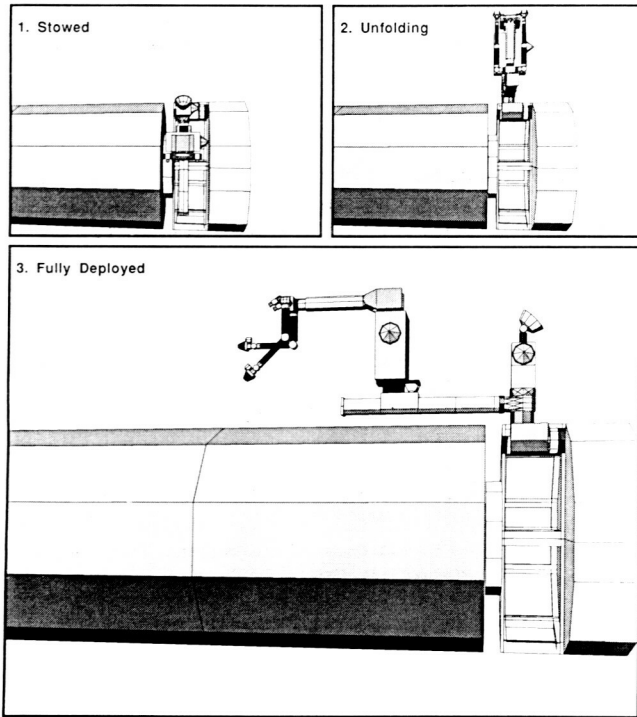

Figure 3. FTS/OMV Servicing

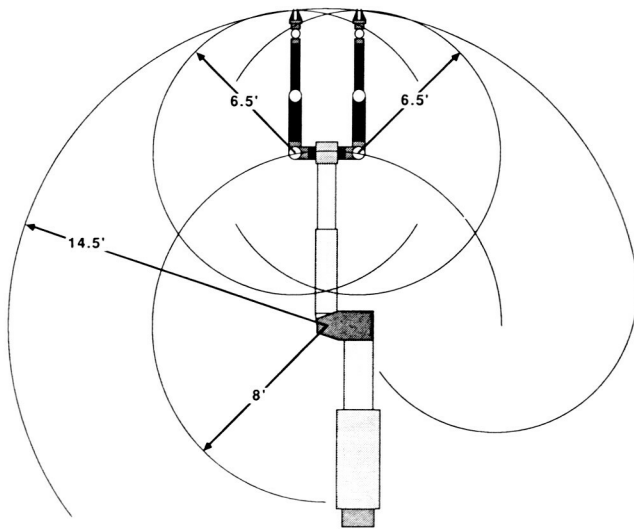

Figure 4. FTS Work Volume

can reach all faces of the bay. The reach of the telerobot at an APAE site is shown in Figure 5 where the Orbital Replaceable Units (ORUs) in the center can be reached from either side, even if larger ORUs are in the way.

The flexibility and controllability of such a system are still areas of concern that are being investigated. Preliminary indications are that the arm positioning system can be made

rigid enough to meet the task requirements. The 5 degrees of freedom in the arm positioning system are controlled open-loop and, therefore, do not contribute complexity to the arm control problem. The degrees of freedom in the positioning system are commanded to set positions one at a time and then rigidly locked before the operator begins to use the manipulator arms. It is not anticipated that the positioning system would be teleoperated through the hand-controllers. The operator could simply key in the position of the joints from a keyboard.

Safety

Safety is of primary importance in the design of the FTS. Safety influences each subsystem and must be designed into the FTS from the start. The Phase B Study approach was to set up a watchdog safety subsystem that consists of redundant radiation hardened computers and associated sensors in the telerobot to monitor all aspects of the telerobot operations and health. Also, the workstation has a safety computer that acts as a global safety monitor for workstation operations as well as the telerobot safety subsystem. Whenever any anomalous condition is detected, the safety computers will stop all movement of the telerobot.

There is also a safety shutdown signal that originates from an astronaut on Extravehicular Activity (EVA) if he senses a problem with the telerobot. This is called the EVA safety link and allows an EVA astronaut to have shutdown control of the telerobot whenever he is working in the vicinity of the telerobot.

Each controller for the manipulator joints is capable of being programmed to limit the local parameters associated with that joint, such as velocity and acceleration. This programming allows the motions of the telerobot to be tailored to the task and the environment. A velocity limit of 1 foot per second is imposed on the manipulators whenever the telerobot is working in the vicinity of an astronaut or critical hardware. Similar limits must be imposed on the maximum momentum the system can attain when moving an object. This may result in an even lower tip velocity, but it ensures that the telerobot can safely brake its motion to avoid collision.

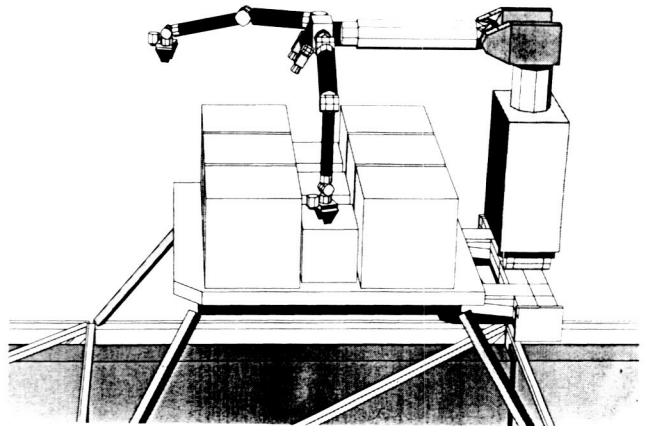

Figure 5. FTS Operating from an APAE

Another safety feature in the telerobot is the inclusion of a small, holdup battery within the telerobot to sustain its functions and to perform an orderly shutdown in the event of a power loss. This safety feature is needed when the telerobot is operating without the large battery in the RSM, and it is deriving its power from the host vehicle.

#### Mobility

Mobility was identified early as an FTS design driver. There is not a requirement for the type of mobility that would allow the telerobot to walk down the Space Station truss. There are other means available on the shuttle and the Space Station to provide global mobility, such as the RMS on the shuttle and the SSRMS on Space Station attached to a transport device such as the Mobile Servicing Centre (MSC) or the Mobile Transporter (MT). However, from a close examination of the FTS tasks, it is clear that some form of "local mobility" (or "robility") was needed at the worksite in order to make the FTS a useful tool on the Space Station.

The local mobility system that is part of the in-house concept is a portable rail that can ride out to the worksite with the telerobot to provide lateral movement. The portable rail, together with the arm positioning system, allows the manipulator arms to be positioned with 6 degrees of freedom at the worksite. The length of the portable rail had to be traded off against the flexibility of the rail and the induced motions at the end of the rail when the telerobot is in operation. The portable rail is attached to the RSM in the in-house concept so that the telerobot/rail/RSM combination can be picked up as one unit and carried to the worksite by one of the transport devices on Space Station. Figure 6 shows the portable rail supporting the telerobot from the RSM.

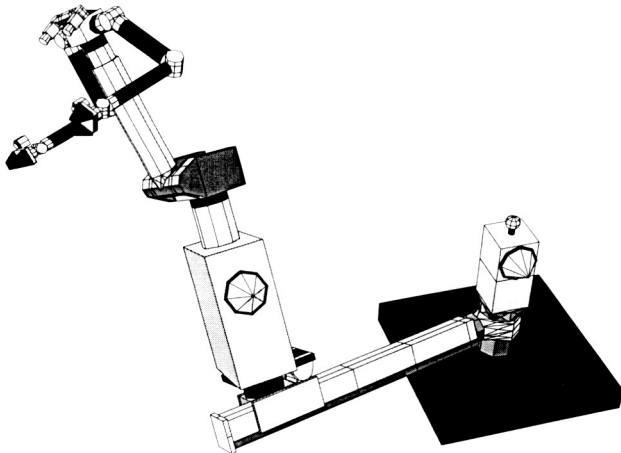

Figure 6. FTS and RMS (Robot Support Module)

#### Evolution

The FTS must be able to evolve towards greater adaptability which includes more autonomous operation that will be accomplished through the incorporation of advanced hardware and software items as they become available. Since

the FTS is intended for permanent residence on the Space Station, new items must be added to the system in orbit. The FTS must be designed to easily accept these changes. This will be done by the incorporation of modularity and accessibility in the design of all subsystems of the FTS and by a careful implementation of the NASREM architecture.

Primary growth areas are expected to be in more advanced computers, upgraded software, advanced sensors with image processing, smart end effectors, and new and more efficient power systems. Also, the manipulator arms could be of a modular design so that they can be reconfigured to provide more capability for new maintenance and servicing tasks on the Space Station. Power, data, and video lines would run throughout the telerobot with standard interfaces defined at the tool plate, arm joints, and other locations where hardware may be added or later changed.

A vision system, which initially is just a closed circuit video system, can easily grow to a stereo-vision system and eventually evolve to full machine vision. Steps that can be taken in the initial design to facilitate this growth are the choice and location of cameras and the interfaces to permit the computers to have access to image data.

#### One-G Operation

Requiring that the telerobot exhibit its full operational capability in the gravity environment of Earth, has far reaching impact on the system design. From a programmatic standpoint, the FTS must be capable of being tested in the performance of representative tasks on Earth before it is committed to launch. However, such a requirement has to be weighed against the impact it causes on the structural, controls, electromechanical, power, and thermal subsystems.

For terrestrial robots, a 100:1 weight-to-lift ratio is not unusual, and a ratio of 10:1 is just now being achieved by some research manipulators such as the Laboratory Telerobotic Manipulators (LTM) being developed by NASA Langley Research Center and the Oak Ridge National Laboratory. This means that if the FTS were required to handle mockup hardware weighing 50 pounds, the manipulators would be on the order of 300 to 500 pounds each using today's technology. This results in 600 to 1,000 pounds for just the manipulators. The total manifested weight for the FTS, including the telerobot and the workstation, is presently 1,500 pounds.

The FTS must undergo a strict weight control program that will result in motors and a structure that will be adequate to accelerate the inertias required by the tasks in the zero-gravity environment of space, but they may not be capable of lifting the mockups of the same hardware on Earth. This will mean that the telerobot will need special assistance to perform its operations in 1 G, such as counterweights and other gravity off-loading devices.

Smaller, lightweight motors are a benefit to both the power and thermal subsystems of the FTS. A lighter weight structure has an impact on the control system since the manipulators will be more flexible, but this is not viewed as an insurmountable problem for the FTS because of the recent advances in algorithms for the control of flexible robots.

## Human Interface

The design of the FTS for the human operator extends beyond the obvious human engineering of the workstation, (e.g., ensuring that the operator is presented with all the necessary displays and controls). The FTS is a teleoperated device where the operator is directly in the control loop. The human interface has a strong influence on the design of the control system, the data system, and the sensors, including the vision system.

The FTS must be designed for operation by one operator. Inventive means must be found for the control of the cameras, illumination, and other peripheral devices when the operator is using both hands to operate the manipulators.

The study team concluded that the use of force reflecting hand controllers should be a requirement for the FTS. This would permit the operator to sense the manipulator forces in his hand controllers. For a teleoperated device, this requirement is a tremendous asset to the operator. It enhances safety when working in an unstructured environment, and it has been proven through documented experiments in the laboratory to reduce errors and overall training time.

The problem on force reflection is the stringent data latency requirement it places on the data system for communications between the workstation and the telerobot. Because the force loop is now closed through the workstation, the stability of the control loop depends upon minimizing the delay time for the round trip signal. The loop should operate at approximately 200 Hz, which results in a latency requirement of 5 msec. The FTS will be using the Data Management System (DMS) on the Space Station to connect the workstation to the telerobot, and an assessment has to be made to see if the DMS can satisfy such a latency requirement.

## CONCLUSION

The Flight Telerobotic Servicer promises to be a useful, reliable, and safe tool to assist the astronauts in performing assembly, maintenance, servicing, and inspection tasks on Space Station and the NSTS. The design challenges have been identified and operational scenarios and task planning have been addressed by the NASA Phase B Study team while candidate designs are being developed by Grumman and Martin Marietta in their Phase B Studies.

The FTS is unique in that it will be required to operate in a much less structured environment than previously developed industrial robots. It will be required to perform

many varied tasks with varying precision throughout its expected lifetime. These tasks will increase in complexity therefore the system must be capable of substantial growth and evolution. It is a program that focuses more on the future than the present technology.

## ACKNOWLEDGEMENTS

The information presented in this paper has been obtained from numerous sources. The major contributors were:

Engineers from—Goddard Space Flight Center, Johnson Space Center, the Jet Propulsion Laboratory, Marshall Space Flight Center, Ames Research Center, Langley Research Center, the National Bureau of Standards, and the Oak Ridge National Laboratories.

Universities—Dr. Richard Voltz, University of Michigan; Dr. Pradeep Khosla, Carnegie Mellon University; and Dr. Edward Haug, University of Iowa. Dr. David Criswell, University of California, San Diego, headed a team of FTS researchers from the Consortium for Space and Terrestrial Automation and Robotics (CSTAR) which included: Dr. George Kondraske, University of Texas, Arlington; Dr. Michael Walker, University of Michigan; Dr. Ken Lauderbaugh, Rensselaer Polytechnic Institute; and Dr. Kai-Hsiung Chang, Auburn University.

Computer graphics—Eugene Aronne, ATR.

## REFERENCES

- [1] *Flight Telerobotic Servicer Requirements Document for Definition and Preliminary Design*, SS-GSFC-0028, April 1987.
- [2] Andary J., S. Hinkal, and J. Watzin, *The Flight Telerobotic Servicer (FTS): A Focus for Automation and Robotics on the Space Station*, Paper IAF-87-25 presented at the 38th Congress of the International Astronautical Federation, Brighton, U.K., October 10-17, 1987; *Acta Astronautica*, Issue 7/8, Vol. 17, July/August 1988.
- [3] *Flight Telerobotic Servicer Strawman Concept Engineering Report*, SS-GSFC-0031, March 15, 1987.
- [4] Albus J., H. McCain, and R. Lumia, *NASA/National Bureau of Standards (NBS) Standard Reference Model for Telerobot Control System Architecture (NASREM)*, SS-GSFC-0027, December 4, 1986.