

N89 - 1987 1

THE WCSAR TELEROBOTICS TEST BED

N. Duffie and J. Zik  
College of Engineering  
University of Wisconsin  
Madison, Wisconsin 53706

R. Teeter and T. Crabb  
Astronautics Corporation of America  
Astronautics Technology Center  
Madison, Wisconsin 53716

ABSTRACT

One of the objectives of the Wisconsin Center for Space Automation and Robotics (WCSAR) at the University of Wisconsin-Madison is the development of component technologies for use in telerobotic systems for space. As part of this effort, a test bed has been established in which these technologies can be verified and integrated into telerobotic systems. The facility consists of two slave industrial robots, an articulated master arm controller, a cartesian coordinate master arm controller, and a variety of sensors, displays and stimulators for feedback to human operators. The controller of one of the slave robots remains in its commercial state, while the controller of the other robot has been replaced with a new controller that achieves high-performance in telerobotic operating modes.

A dexterous slave hand which consists of two fingers and a thumb is being developed, along with a number of force-reflecting and non-force reflecting master hands, wrists and arms. A tactile sensing finger tip based on piezo-film technology has been developed, along with tactile stimulators and CAD-based displays for sensory feedback and sensory substitution.

This paper describes the WCSAR telerobotics test bed and the component technologies that are incorporated in it. It also describes their integration of these component technologies into telerobotic systems, and their performance in conjunction with human operators.

INTRODUCTION

Autonomous robots working in industrial environments, typically, replace human workers performing well structured and repetitive tasks. Advanced teleoperated systems, on the

other hand, extend the human manipulation, sensing and cognitive capabilities to remote locations. This shields the operator from the hazards of working in the task environment. The need for use of both autonomous and teleoperated (or a combination of the two) robotic systems for space applications is well recognized by NASA [1] and the aerospace community. Major emphasis in much of this work is placed on developing [2] human-like robotic systems that would replace humans in extra-vehicular activities. This includes a major effort by NASA for the development of the Flight Telerobotic Servicer.

The work underway at the Wisconsin Center for Space Automation and Robotics (WCSAR) is designed to complement such efforts by developing modular and add-on technologies that would improve the effectiveness of such systems as well as enhance effective utilization of automation and robotics in commercial activities in a space environment. The emphasis is on the development of new component and system technologies that will not only utilize, but improve the existing automation and robotic technologies for applications involving assembly, maintenance and servicing of space platforms, stations, commercial satellites and future production and life support facilities. The technology areas of near-term are those that enhance dexterity, sensory perception, performance, and telepresence in telerobotic systems

WCSAR is a NASA-funded Center for Commercial Development of Space (CCDS) and was founded in 1986. It provides an organizational structure that fosters the co-sponsorship of commercial application of space automation and robotics between industrial partners and associated universities. At present, WCSAR has three active project areas: (1) Astrobotics™ - Robotic Technology Development; (2) Astroculture™ - Automated Plant Growth Facilities for Space; and (3) Astrofuel™ - Automated Lunar Resource Processing Systems. These are being pursued by interdisciplinary teams formed by WCSAR's university and industrial partners.

The layout of the WCSAR telerobotics test bed is shown in Figure 1. It consists of three major subsystems:

- 1) **Cincinnati Milacron Robot with Enhanced Control and Dexterous Hand.** This subsystem consists of a Cincinnati Milacron T<sup>3</sup>-726 electric-drive robot, an ACA dexterous slave hand, a number of master hands, and a non-kinematic replica master arm as illustrated in Figures 2 and 3. The original controller of the robot has been replaced with a new, higher-performance controller designed at WCSAR which is capable of being flexibly programmed in a number of telerobotic operating modes.
- 2) **ASEA Industrial Robot with Telerobotics Inc. Gripper.** This subsystem consists of an ASEA IRB 6/2 electric-drive robot, its controller, a cartesian coordinate master arm, a Telerobotics, Inc. slave gripper, and a force-reflecting master gripper as illustrated in Figures 4 and 5. Control of the ASEA is accomplished with a host computer as the master, serially linked to the ASEA controller via a standard RS232C communication port on the ASEA.
- 3) **Space Shuttle Aft Flight Deck Mock-Up.** High-performance telerobots working in space with sensory feedback to the operator will need to be operated from workstations in space within reasonable communications proximity. One likely workstation location is the aft flight deck of the Shuttle; another is the Space Station. A mock-up of the aft-flight deck of the Space Shuttle is included in the test bed for the purpose of simulating teleoperation in a space environment. It serves to isolate operators of telerobotic experiments from slave hardware, thus insulating them from visual and audio cues that would not be present in space.

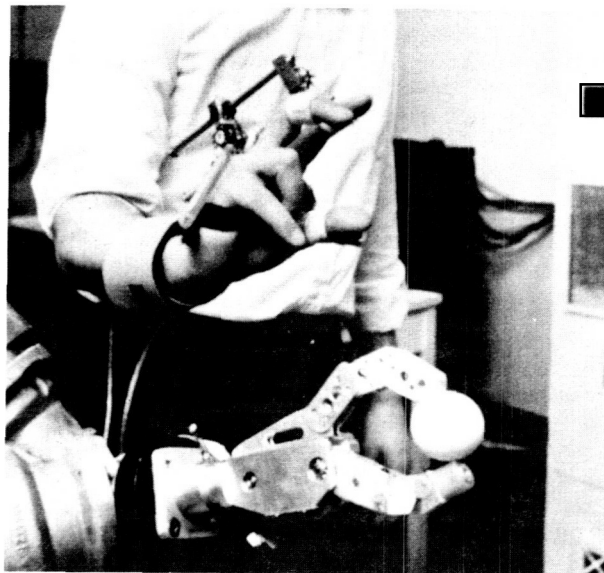

Figure 2. "Milacron" subsystem with dexterous slave hand

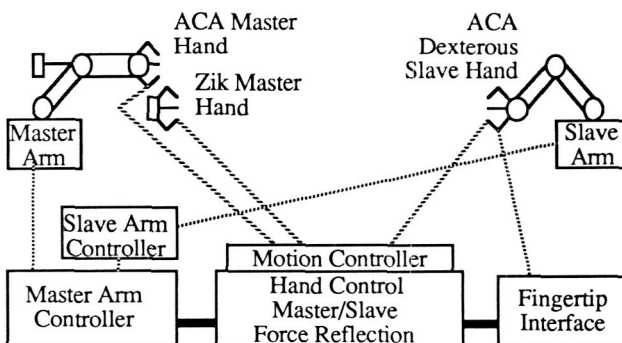

Figure 3. Schematic of "Milacron" master/slave subsystem

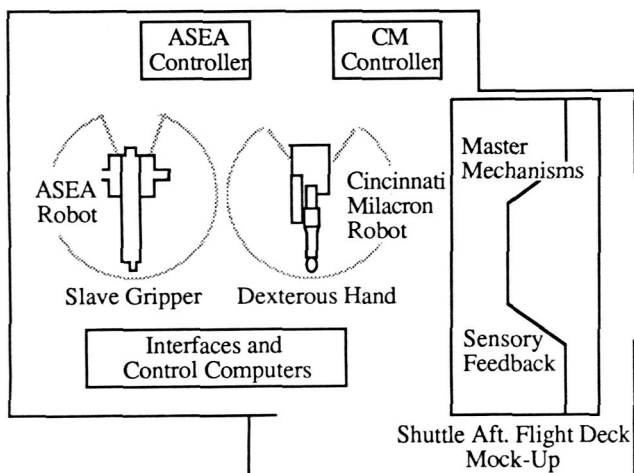

Figure 1. WCSAR Telerobotics Test Bed

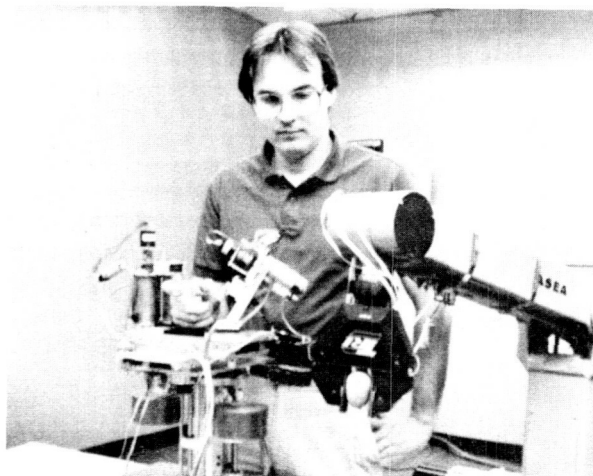

Figure 4. "ASEA" subsystem with master/slave dexterous hand

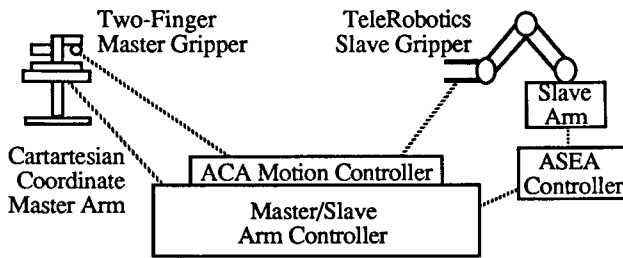

Figure 5. Schematic of "ASEA" master/slave subsystem

### MASTER HANDS, WRISTS AND ARMS

Table I lists a number of devices that have been or are presently being developed at WCSAR. The first developments were centered around the "ASEA" subsystem and the master arm and hand shown in Figure 4. With a cartesian master arm interfaced to the robot using a standard communication interface, teleoperation control of the robot was achieved relatively quickly. However, performance in this system is limited by low-speed communications. The cartesian coordinate master provides a large mounting platform to locate the master hand which incorporates drive motors for force reflecting fingers. This setup will allow WCSAR to perform a series of force-reflecting experiments using the parallel motion slave hand.

Next, a master arm and wrist was developed which provides six-degrees-of-freedom for control of the "Milacron" subsystem shown in Figure 2. Also, a number of dexterous master hands have been developed to interface with the dexterous slave hand. Figure 6 shows a light-weight master hand with no force reflection. This device is referred to as "Laird H1" in Table I and features three fingers, each with three degrees of freedom.

Figure 7 shows one finger of a force reflecting master hand that is under development. Its features include:

- a three finger design which allows for object manipulation;
- three degrees-of-freedom per finger which allow for various types of finger manipulation;
- force reflection to enhance telepresence and reduce task completion time;
- low friction and inertia; and
- position range same as a human finger;

The device mounts to a bracket that is fixed to the back of the operator's hand (not shown in Figure 7). Forces are transmitted to the operator's finger through a

tendon/pulley/linkage system [3,4]. Attachment to the finger is realized with a ring that fits around the finger. Force reflection is implemented using four remotely-located motors. Torque from the motors is transmitted directly to the master finger. One finger of the master hand has been manufactured and is currently undergoing testing.

Table I. Master arm/wrist/hand developments

Component	Characteristics	Status
Cartesian Coordinate Arm Master (Zik A1)	<ul style="list-style-type: none"> <li>• Cartesian coordinate configuration with three degrees-of-freedom</li> <li>• Standard industrial interface (RS232 comm. to ASEA)</li> </ul>	Complete
Non-Kinematic Replica Master Hand Type A (Zik H1)	<ul style="list-style-type: none"> <li>• Two digit (finger) device</li> <li>• One degree-of-freedom per digit</li> <li>• Force reflection implemented</li> <li>• Actuators local</li> </ul>	Complete
Non-Kinematic Replica Master Hand Type B (Laird H1)	<ul style="list-style-type: none"> <li>• Three digit (finger) device</li> <li>• Three degrees-of-freedom per digit</li> <li>• Force reflection provided with one drive motor per finger</li> <li>• Actuators local</li> </ul>	Complete
Non-Kinematic Replica Master Hand Type C (Laird H2)	<ul style="list-style-type: none"> <li>• Three digit (finger) device</li> <li>• Three degrees-of-freedom per digit</li> </ul>	Complete
Non-Kinematic Replica Master Hand Type D (Zik H2)	<ul style="list-style-type: none"> <li>• Three digit (finger) device</li> <li>• Three degrees-of-freedom per digit</li> <li>• Force Reflection provided with each degree-of-freedom</li> <li>• Actuators remote</li> </ul>	Currently being manufactured
Non-Kinematic Replica Master Hand Type E (ACA H1)	<ul style="list-style-type: none"> <li>• Three digit (finger) device</li> <li>• Two degrees-of-freedom per digit</li> </ul>	Currently being manufactured
Non-Kinematic Replica Master Arm/Wrist (Zik A2)	<ul style="list-style-type: none"> <li>• Six degrees-of-freedom</li> <li>• Mechanically counterbalanced</li> <li>• Three intersecting axis wrist configuration with hand grip in center of wrist</li> </ul>	Currently being manufactured

### THREE-FINGERED DEXTEROUS SLAVE HAND

The Astronautics Corporation of America (ACA) dexterous slave hand is under development in conjunction with WCSAR and the State of Wisconsin and has the following features:

- dexterity is achieved with three digits, eight or nine movable joints, and five to seven independent movements;
- power and speed are similar to the human hand;
- self-contained actuators are in a single mechanical module;
- capability of operating in teleoperation modes with reflected force and compliant control;
- minimal size and weight;
- simplicity and robustness suitable for space and commercial use; and
- precision and controllability.

A prototype of one of the three digits has been fabricated, assembled and tested as shown in Figure 2. The three-fingered slave hand consisting of three fingers and a thumb is illustrated in Figure 8, and its testing in the test bed will begin at the end of July, 1988.

### TACTILE SENSORS AND STIMULATORS

Tactile feedback in a telerobotic system can provide the operator with an accurate sense of a presence when the operator is manipulating and contacting objects with the remote slave device. One concept currently being investigated is shown schematically in Figure 9. It consists of three major elements: sensors, displays, and the stimulator interface. The sensors currently used include very small piezoresistive devices that are highly sensitive to pressures of less than 3 psi, and are mounted to the slave in areas where tactile contact is most common and most useful. The sensors will be attached to the parallel jaw grippers on the "ASEA" subsystem and to the dexterous hand on the "Milacron" subsystem to conduct typical EVA tasks in a teleoperated mode.

Because human visual and auditory sensory inputs may be heavily utilized in a telerobotic system during these tasks, tactile stimulation has been the primary display mechanism to the operator. The goal of the system is to provide this stimulation directly to the operator's hand in a pattern matching the sensor pattern on the slave hand. This direct mapping of the slave sensors and the master stimulators will yield a comfortable system with the least amount of operator interpretation and training required.

### ROBOTIC FINGERTIP SENSOR

Researchers at WCSAR have adapted a four-degree-of-freedom, tactile fingertip sensor, originally developed for manufacturing applications [5], for use in teleoperated systems. Integration of this fingertip on the dexterous hand will allow WCSAR to develop sensitive force feedback from the slave

robot and enhance telepresence. Eventually, the sensor will allow a teleoperated robot to grasp fragile objects and do delicate work. The fingertip:

- can be optimized with respect to its shape and its sensing element size and location to give favorable signal characteristics;
- is linear over a reasonable range of applied forces;
- has low hysteresis and good repeatability;
- can be linearly decoupled to allow measurement of four degrees-of-freedom appropriate for fingertip grippers. (normal force, two tangential force components, and torque about the normal force axis [6]);
- is inert to most environmental influences;
- can be easily constructed with minimal material costs; and
- can be made rugged, yet possesses sufficient compliance for practical force control.

The basic concept of the sensor is shown in Figure 10. The sensor is constructed of two materials: room temperature vulcanizing (RTV) silicone rubber, which is used as a compliant, homogeneous, bulk base material, and polyvinylidene fluoride (PVDF) film, which is the piezoelectric polymer used to detect strains in the rubber. When a force is applied to the fingertip sensor, deformation in the rubber results. This deformation is transferred to four strips of piezoelectric film which are bonded to the rubber's surface. The shift in electrical charge in the strained piezoelectric film is the signal used to measure the forces applied to the sensor.

Each different component of the force applied to the sensor, whether it is normal, tangential, or torque, will produce a unique signal in each of the four pieces of piezo-film. Therefore, after the signals have been amplified, the signals must be sent to a computer for decoupling which will resolve the applied force into its independent components. The characteristics of the fingertip are listed in Table II.

Table II. Characteristics of fingertip sensor

Linearity	1% Error at 4 Pounds of Normal Force
Hysteresis	3% Error at 7 Pounds of Normal Force
Repeatability	< 1% Error at 5 Pounds of Normal Force
Range	0.5 Ounces to 15 Pounds

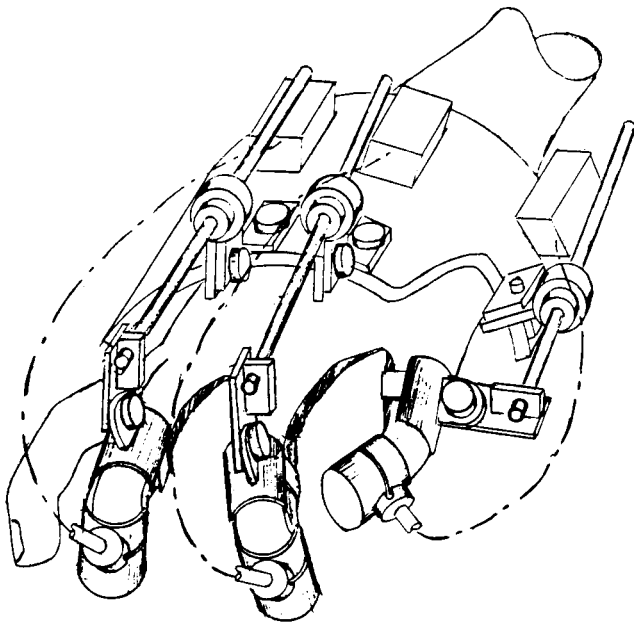

Figure 6. Non force-reflecting master finger

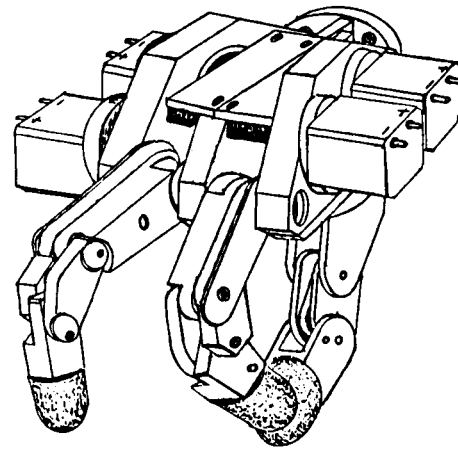

Figure 8. Three-Fingered Dexterous Slave Hand

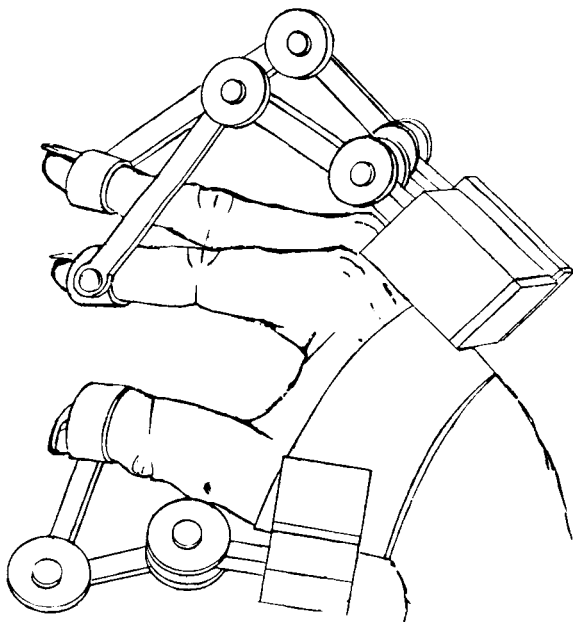

Figure 7. Force-reflecting master finger

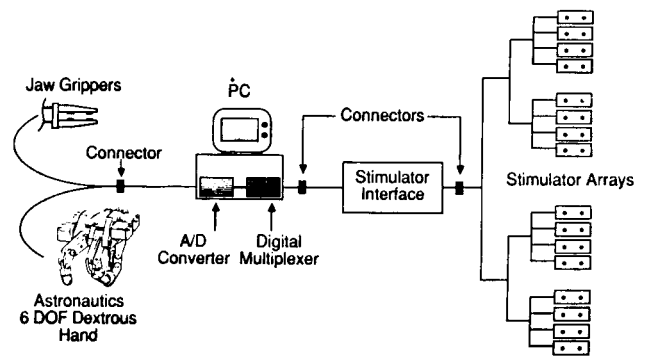

Figure 9. Tactile Feedback System

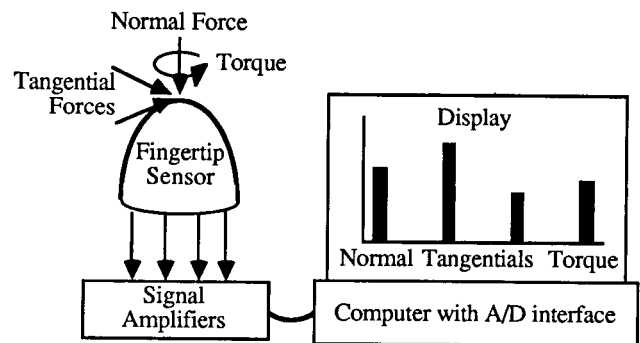

Figure 10. Fingertip sensor and signal processing system

## HUMAN FACTORS EXPERIMENTS

Sustained operation of exoskeletal master controllers, particularly force-reflective systems, can be a fatiguing and uncomfortable experience if operational and feedback force levels are not properly adjusted for the individual operator. Though there is no guidance at this time for specifying these levels, previous exertion experiments have demonstrated that perceptions of force change with onset of localized muscle fatigue and discomfort [7,8]. One of WCSAR's objectives is to help develop a comfortable and fatigue-resistant master controller device which may be used in sustained manipulation and gripping activities by a wide ranging population.

WCSAR is now conducting a series of experiments, using apparatus such as that shown schematically in Figure 11. The objective is to determine the force-of-operation and end-effector force-feedback levels that can be endured for sustained periods in teleoperated systems (e.g. 2 hours) without encountering material signs and symptoms of fatigue and discomfort, and without altering the operator's perception of force produced or experienced at the end-effector. These experiments will help to produce performance response models which will account for differences in task duration, manipulation duty cycle (i.e. percent of time exerting against the manipulator), criticality of task force perception requirements, and an individual's pinch strength and psychometric sensitivity limitations.

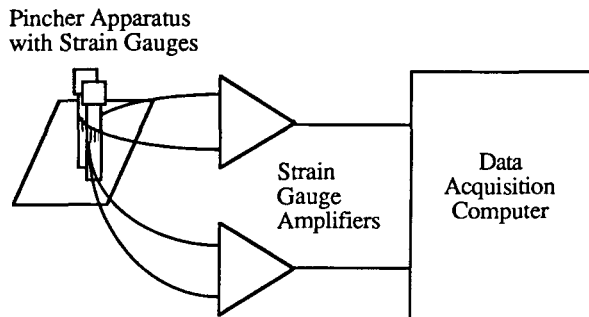

Figure 11. Apparatus for force-of-operation experiments

## CONCLUSION

The work underway at the Wisconsin Center for Space Automation and Robotics (WCSAR) emphasizes the development of modular and add-on technologies that enhance dexterity, sensory perception, and performance in telerobotic systems. The component technologies described in this paper, and other related developments, are now being verified in the experimental telerobotic systems in the test bed. This will lead to their refinement and eventual availability for use in

telerobotic servicing systems being developed for space. We also expect significant terrestrial application spin-offs. Component developments being integrated into the WCSAR test bed will lead to enhanced capabilities at the system level. This will allow sophisticated human/sensor/actuator systems to be evaluated, with the results leading to practical systems with high levels of productivity and low levels of operator fatigue.

## ACKNOWLEDGEMENTS

This work was supported by the Wisconsin Center for Space Automation and Robotics in part by NASA under grant NAG-W975 and by a consortium of industrial sponsors.

## REFERENCES

- [1] Flight Telerobotic Servicer (FTS), Strawman Concept Engineering Report, Goddard Space Flight Center, Maryland, SS-GSFC-0031, March 1987.
- [2] French, R., and Boyce, B., "Satellite Servicing by Teleoperators," ASME Journal of Engineering for Industry, Vol. 107, pp. 49-54, Feb., 1985.
- [3] Mason, M., and Salisbury, J., Robot Hands and the Mechanics of Manipulation, The MIT Press, Cambridge, MA, 1985.
- [4] Jacobsen, S. et. al., "Design of the UTAH/M.I.T. Dexterous Hand," IEEE Intl. Conf. on Robotics and Auto., San Francisco, CA, April, 1986, pp. 1520-1532.
- [5] Lorenz, R., Meyer, M. and Van De Riet, D., "A Novel, Compliant, Four Degree-of-Freedom, Robotic Fingertip Sensor," to be presented at the IEEE-IAS Annual Meeting, Pittsburgh, PA, Oct. 3-7, 1988.
- [6] Badreldin, A., and Seireg, A., "Optimizing the Handling of Objects with Multi-Fingered Grippers," Computers in Mechanical Engineering, March/April, 1988, pp. 47-57.
- [7] Hightower, J., Smith, D., and Wiker, S., "Developments of Remote Presence Technology for Teleoperated Systems," Proc. of the 14th Meeting of the United States-Japan Natural Resources Comm. of the Marine Facilities Panel, Bethesda, MD, Sept. 19-20, 1988.
- [8] Sharum, J. and Chafin, D., "Force Judgement Decrements Following Muscle Exertions," Technical Report of the Human Performance Research Group, Dept. of Industrial Engineering, University of Michigan-Ann Arbor, 1970.