

N89-20138**PRECEDING PAGE BLANK NOT FILMED****ASSESSMENT, DEVELOPMENT, AND APPLICATION OF COMBUSTOR
AEROTHERMAL MODELS****J. D. Holdeman**National Aeronautics and Space Administration
Lewis Research Center
Cleveland, Ohio**H. C. Mongia**Allison Gas Turbine Division
General Motors Corporation
Indianapolis, Indiana**E. J. Mularz**Propulsion Directorate
U.S. Army Aviation and Technology Activity – AVSCOM
NASA Lewis Research Center
Cleveland, Ohio**ABSTRACT**

The gas turbine combustion system design and development effort is an engineering exercise to obtain an acceptable solution to the conflicting design trade-offs between: combustion efficiency, gaseous emissions, smoke, ignition, restart, lean blowout, burner exit temperature quality, structural durability, and life cycle cost. For many years, these combustor design trade-offs have been carried out with the help of fundamental reasoning and extensive component and bench testing, backed by empirical and experience correlations.

Recent advances in the capability of computational fluid dynamics (CFD) codes have led to their application to complex three-dimensional flows such as those in the gas turbine combustor. A number of U.S. Government and industry sponsored programs have made significant contributions to the formulation, development, and verification of an analytical combustor design methodology which will better define the aerothermal loads in a combustor, and be a valuable tool for design of future combustion systems. The contributions made by NASA Hot Section Technology (HOST) sponsored Aero-thermal Modeling and supporting programs are described in this paper.

INTRODUCTION

The goal of gas turbine combustion system design and development is to obtain an acceptable solution to the conflicting design trade-offs between combustion efficiency, gaseous emissions, smoke, ignition, restart, lean blowout, burner exit temperature quality, structural durability, and life cycle cost. For many years, these combustor design trade-offs have been carried out with the help of fundamental reasoning and extensive component and bench testing, backed by empirical and experience correlations. The ultimate goal has been to develop a reliable combustor design system that can provide quantitatively accurate predictions of the complex combustion flow field characteristics (Fig. 1) so that an optimum combustion system design can be achieved within reasonable cost and schedule constraints.

Empirically based procedures have led to successful evolutionary combustor improvements. However, as these methods are experience-based, they are not well suited when combustor design requirements are significantly different from that of current technology engines. The rapidly developing CFD (Computational Fluid Dynamics) capability is providing an additional tool in the design process which can have a powerful positive influence on future design capability. In these codes, combustion system subcomponents including diffusers, fuel injectors, and combustor liners, in addition to the complex internal flow, need to be accurately modelled. To achieve this, physical sub-models and accurate numerical schemes must be developed to describe the various aerothermochemical processes occurring within the combustion chamber.

A number of U.S. Government and company sponsored programs have made significant contributions to the formulation, development, and verification of an analytical combustor design methodology. These have included: U.S. Army Combustor Design Criteria Validation (Bruce et al., 1979; Mongia et al., 1979, Mongia and Reynolds, 1979), NASA Swirling Recirculating Flow (Srinivasan and Mongia, 1980), NASA Soot and NO_x Emissions Prediction (Srivatsa, 1980), NASA Primary Zone Study (Sullivan et al., 1983), NASA Mass and Momentum Transfer (Johnson and Bennett, 1981; Roback and Johnson, 1983; Johnson et al., 1984), NASA Lateral Jet Injection (Lilley, 1986; Ferrell and Lilley, 1985; McMurray and Lilley, 1986; Ong and Lilley, 1986), NASA Dilution Jet Mixing (Srinivasan et al., 1982, 1984, 1985; Srinivasan and White, 1986; Holdeman et al., 1984; Holdeman and Srinivasan, 1986; Holdeman et al., 1987a), NASA Transition Mixing Study (Reynolds and White, 1986; Holdeman et al., 1987b), NASA HOST Aero-thermal Modeling (Kenworthy et al., 1983; Sturgess, 1983; Srinivasan et al., 1983a, 1983b), NASA Error Reduction (Syed et al., 1985), industry IR & D programs, and advanced combustor development programs.

The NASA Hot Section Technology (HOST) Combustion Program has supported several of these programs. The overall objective of the HOST Combustion Project is to develop and verify advanced analytical methods to improve the capability to design combustion systems

ORIGINAL PAGE IS OF POOR QUALITY

for advanced aircraft gas turbine engines. This objective is being approached both computationally and experimentally.

Computationally, HOST first sponsored studies to assess and evaluate the capabilities of existing aerothermal models (circa 1982). Based on the results of these assessments and other studies in the literature, HOST supported several studies to develop new and improved numerical methods for the analysis of turbulent viscous recirculating flows, with emphasis on accuracy and speed of solution.

The objectives of HOST sponsored experimental studies were to improve understanding of the flow physics and chemistry in constituent flows, and to obtain fully-specified, benchmark-quality experimental data suitable for the assessment of the capabilities of advanced computational codes.

This paper reviews the advances in the state-of-the-art in combustor aerothermal modeling, while highlighting the programs supported by the HOST Project (Turbine Engine Hot Section Technology, 1982, 1983, 1984, 1985, 1986, 1987). Due to length limitations not all programs that received HOST support are included, and, for completeness, some programs that made a significant contribution, but which did not draw their primary support from HOST are discussed.

AEROTHERMAL MODELING ASSESSMENT

Gas turbine combustion models include submodels of turbulence, chemical kinetics, turbulence/chemistry interaction, spray dynamics, evaporation/combustion, radiation, and soot formation and oxidation. A very extensive assessment of numerics, physical submodels, and the suitability of the available data was made by three contractors under Phase 1 of the HOST Aerothermal Modeling program (Kenworthy et al., 1983; Sturgess, 1983; Srinivasan et al., 1983a, 1983b). These investigations surveyed and assessed current models and identified model deficiencies through comparison between calculated and measured quantities. Results of the assessment by Srinivasan et al., (1983a, 1983b) are summarized by Mongia et al. (1986). The constituent flows examined included: (1) simple flows with no streamline curvature, (2) complex flows without swirl, and (3) complex flows with swirl. Geometries for several test cases from each of these categories are shown in Fig. 2.

k-ε Turbulence Model

The k-ε model is the simplest turbulence model that is suitable for recirculating flow calculations. This model achieves closure by using a gradient transport model for Reynolds stress with an isotropic eddy viscosity. For flows where the isotropic eddy viscosity assumption is not valid, the k-ε model may be either modified (e.g. low Reynolds number correction, Richardson number correction) or replaced with an algebraic or differential Reynolds stress model.

Assessment of the k-ε model(s) of turbulence showed that these models:

- (1) require low Reynolds Number correction for predicting wall shear flows, and streamline curvature modifications for accurately predicting curved boundary layers
- (2) give quantitatively good correlation with data for simple flows and non-recirculating swirling flows
- (3) give quantitatively reasonable results for nonswirling recirculating flows

- (4) give quantitatively unsatisfactory correlation with data for complex swirling flows with recirculation zones
- (5) give quantitatively unsatisfactory correlation, but predict trends correctly, for complex three-dimensional flows.

Algebraic Stress Model and Its Modifications

Mean flow predictions with this model agreed with the data as well as the k-ε model results, therefore the conclusions above also apply to this model. In addition, the Algebraic Stress Model gives reasonable predictions for the Reynolds stress components, consistent with the strengths and limitations of the k-ε models (Mongia et al., 1986).

The results of standard k-ε and algebraic and differential Reynolds stress turbulence models, have been compared in several continuing assessment studies. An example comparison (Mongia, 1987) of data and calculations using a hybrid/SIMPLE numerical scheme is shown in Fig. 3. This flow is that of co-annular turbulent jets flowing into an axisymmetric sudden expansion (Roback and Johnson, 1983). In this figure, velocity profiles are shown at downstream, distance from 0.11 to 2.5 pipe diameters from the expansion.

Scalar Transport Model

Mongia et al., (1986) reported that the k-ε model with specified Prandtl number predicts scalar fluxes reasonably well for flow where the gradient diffusion approximation is valid. An alternative, the algebraic scalar transport model, has the capability to improve predictions over the k-ε approach, but further work is needed to establish its validity for swirling recirculating flows.

Turbulence/Chemistry Interaction Models

It was also concluded by Mongia et al., (1986) that both 2- and 4-step reaction schemes showed promise for application in gas turbine combustors, but need to be further validated against data from simple flames. The modified eddy breakup model predicted trends well, and it was recommended that it should be pursued because this approach could be easily extended to multistep kinetic schemes.

Numerical Accuracy

A significant deficiency identified in the assessments was that for many flows of interest the accuracy of the calculation was limited by the numerical approximations, wherein the false diffusion is of the same order of magnitude as the turbulent diffusion. This masked the differences between turbulence models such that very different models gave essentially the same result, and sometimes resulted in undeservedly good agreement between data and predictions.

If false diffusion is present, the numerical solution obtained for any given flow depends on the grid density and distribution. An example of the comparisons made in the assessment program is given by the comparison in Figs. 4 and 5 between measured and calculated temperature distributions downstream from a row of jets entering a confined crossflow. This flow is a constituent flow in most gas turbine combustors, and has been treated extensively in the literature, including the recently completed NASA Dilution Jet Mixing program, from which data were compared with three-dimensional calculations in the Phase I assessment study by Srinivasan et al., (1983).

ORIGINAL PAGE IS OF POOR QUALITY

The calculated and experimental results shown are for a single row of jets with an orifice spacing to diameter ratio, S/D , = 2 injected into a ducted mainstream with a duct height to orifice diameter ratio H/D , = 8. The jet-to-mainstream momentum flux ratio, J , for this test was 25.32. Calculations for this case made with $45 \times 26 \times 17$ (19890) nodes, are shown in Fig. 4. The parameter plotted in these figures is the dimensionless mean temperature difference ratio, θ , where $\theta = (T_m - T)/(T_m - T_j)$. The predicted jet penetration and mixing are less than that shown by the data.

The calculation shown in Fig. 4 used 49 nodes to simulate each jet. It is generally not possible to use this many grid points in such a small region; as few as four may be used in practice for each jet. To simulate the accuracy of this approximation, calculations were performed for the same flow and geometric conditions, but with a $27 \times 26 \times 8$ (5615) grid. These coarse-grid calculations (Fig. 5) are in much better agreement with the data than the fine-grid calculations. These and other calculations in Srinivasan et al., (1983b) clearly demonstrated that the three-dimensional calculations were not grid independent.

Conclusions from the Assessments

The major conclusion in the HOST Aerothermal Modeling Phase I assessment studies by Kenworthy et al. (1983), Sturgess (1983), and Srinivasan et al. (1983a, 1983b) was that the available computational fluid dynamics (CFD) codes provided a useful combustor design tool. Although significant advances have been made in the development and validation of multidimensional gas turbine combustion calculation procedures, the codes assessed were only qualitatively accurate, especially for complex three-dimensional flows, and further work was needed. It was concluded that both a significantly improved numerical scheme and fully-specified experimental data (i.e. both mean and turbulence flowfield quantities, with measured boundary conditions) for complex non-reacting and reacting constituent flows were needed before various emerging physical sub-models of turbulence, chemistry, sprays, turbulence/chemistry interactions, soot formation/oxidation, radiation, and heat transfer could be properly assessed.

A SECOND GENERATION MODEL

The first generation combustor design procedure outlined by Mongia and Smith (1978) has been very useful for developing several combustors (Mongia et al., 1986) that exhibited significant technology advances. However, in addition to the model deficiencies identified in the assessments, there were several parameters of importance in gas turbine combustor design that the analytical models could not predict; e.g. gaseous emissions, soot formation, flame blow-out limits, combustor pattern factor, and liner heat transfer. These parameters were, however, successfully predicted by well-established semi-analytical correlations developed by Plee and Mellor (1980), Leffevre (1985), and their associates. Therefore, a combustor design procedure that could be applied to current and future gas turbine engines was implemented that makes use of empirical design concepts and employs analytical modeling tools to represent various combustion processes (Rizk and Mongia, 1986; Mongia, 1987).

This method makes use of multidimensional models to establish liner flowfield features and combustion characteristics. The analytical results are then integrated with semi-empirical correlations for

performance parameters of interest. That is, flow field and geometric parameters that are needed in the empirical equations, such as combustion volume and the fraction of air participating in the primary combustion reaction, are provided by the analytical calculations.

Satisfactory agreement with experimental data has been shown (Rizk and Mongia, 1986) for emissions, performance and heat transfer. The combustor for which data were available, and for which calculations were performed, is shown schematically in Fig. 6. A typical comparison between data and predictions for CO, unburned hydrocarbons, NOx, soot emissions, combustion efficiency, pattern factor, and lean blowout are shown in Figs. 7(a) to (g) respectively. The model is in good agreement with the data over the entire sea-level engine operating range. Calculated liner wall temperatures for both the inner and outer walls of this combustor are shown in Fig. 8 for three typical z-planes along $k = 5, 14, \text{ and } 23$. Here k denotes nodal planes along the combustor circumferential direction. Although no direct comparison with liner wall temperature data was made, the predictions look reasonable.

AEROTHERMAL MODELING PHASE II

Based on the recommendations of the Phase I assessment studies, activities in Phase II of the HOST Aerothermal Modeling program concentrated on developing improved numerical schemes, and collecting completely-specified data for nonreacting single and two-phase swirling and nonswirling flows. The programs initiated were: Improved Numerical Methods; Flow Interaction Experiment; and Fuel Injector/Air Swirl Characterization. The first of these is a prerequisite to further model development, and the data obtained in the latter two studies will be used to validate advanced models being developed independently.

Improved Numerical Methods

The hybrid finite differencing scheme employed in generally available combustor codes gives excessive numerical diffusion errors which preclude accurate quantitative calculations. In response to this deficiency, HOST supported three programs with the primary objective to identify, assess, and implement improved solution algorithms applicable to analysis of turbulent viscous recirculating flows. Both solution accuracy and solution efficiency were addressed (Turbine Engine Hot Section Technology, 1985, 1986, 1987; Turan and VanDoormal, 1987).

For most practical problems, a central differencing scheme would be ideally suited if it were unconditionally stable. Central differencing is a simple second-order scheme which is easy and straightforward to implement. However, for grid Peclet numbers larger than 2, central differencing can lead to over- and under-shoots and is unstable. The hybrid (central/upwind) scheme is stable for all Peclet numbers, but suffers from excessive false diffusion. An alternative scheme, named CONDIF (Controlled Numerical Diffusion with Internal Feedback) (Runchal et al., 1986) has unconditionally positive coefficients and still maintains the essential features of central differencing and its second-order accuracy.

CONDIF uses central differencing when $Pe < 2$. Where $Pe > 2$ and the dependent variable varies monotonically, a modified central differencing scheme is used, otherwise upwind differencing is used. CONDIF employs just enough numerical diffusion to ensure stability based internally on the field distribution of

ORIGINAL PAGE IS OF POOR QUALITY

the variable, rather than switching to upwind differencing whenever Pe exceeds 2. Since upwinding is done at relatively few grid points, CONDIF essentially maintains the second-order accuracy of central differencing, and false diffusion is substantially reduced.

Another advanced numerical scheme, called flux-spline (Patankar et al., 1987), is based on a linear variation of total flux (convection + diffusion) between two grid points. This is an improvement over the assumption of uniform flux used in hybrid schemes, and leads to reduced numerical diffusion.

Both of these schemes have been used to solve a variety of analytical, two-dimensional laminar and turbulent flows (Runchal et al., 1987; Patankar et al., 1987). As an example, results for a laminar flow ($Re = 400$) in a square driven cavity are shown in Fig. 9. This flow, shown schematically in part a), is characterized by a strong recirculation zone typical of many physical situations. The problem was solved with both CONDIF and flux-spline schemes on a uniform 22×22 grid and compared with the exact analytical solution and a hybrid solution on an extremely fine 82×82 grid. Velocity profiles at the midsection of the cavity are shown in Fig. 9(b). Both advanced schemes show improvement over the hybrid calculation.

An attractive feature of both CONDIF and flux-spline schemes is that their extension to three dimensions is relatively straight-forward. The resulting linear differential equations involve only seven points as opposed to 27 points needed in many skewed-upwind schemes (Syed et al., 1985).

In addition to the need for improved numerical accuracy, there is a need for improved computational efficiency for a given level of accuracy. Typically the continuity and momentum equations are solved separately, and then linked through iteration of the pressure term; e.g. SIMPLE (Semi-Implicit Method for Pressure Linked Equations). Modifications, such as SIMPLER and PISO, have been shown to improve computational efficiency. Other advanced schemes (Turbine Engine Hot Section Technology, 1985, 1986, 1987; Vanka, 1987), such as block correction techniques and direct solution of the coupled equations have been proposed. Calculations with the latter coupled with the flux-spline technique have shown a speed increase by a factor of 15 for a calculation of turbulent flow over a backward-facing step (Mongia, 1987).

Gas Phase Experiments

An experimental study of the interactions between the combustor and diffuser systems (Srinivasan and Thorp, 1987) is in progress to:

- (1) Identify the mechanisms and magnitude of aerodynamic losses in various sections of an annular combustor-diffuser system
- (2) Determine the effects of geometric changes in the prediffuser, dome, and shroud on these losses
- (3) Obtain a data base to assess current and advanced aerodynamic computer models for predicting these complex flowfields
- (4) Upgrade the analytical models based on the experimental data
- (5) Design and test advanced diffuser systems to verify the accuracy of the upgraded analytical model

Another study in progress will obtain comprehensive mean and turbulence measurements of velocity and species concentration in a three-dimensional flow model of the primary zone of gas turbine combustion chambers (Turbine Engine Hot Section Technology, 1985, 1986,

1987). The flowfield of interest is the interaction between swirling flow and lateral jets in a rectangular channel (Fig. 10). The mainstreams flow enters through 5 swirlers with the transverse jets injected from both the top and bottom duct walls with either 2 or 4 jets per swirler at $1/2$ or 1 channel height downstream from the swirler.

These experiments are being conducted on both air and water multiple-swirler rigs, as well as single swirler and swirling jet rigs. Fifteen cases (combinations of swirl and jet strength and location) are under test using laser sheet light and dye water flow visualization, and detailed velocity and scalar mean and turbulence LDV measurements are being made in the air rig.

A key feature of this program is comparison of model calculations against the data obtained to ensure that the data are complete and consistent, and satisfy the boundary condition input requirements of current three-dimensional codes. Calculations were performed using a three-dimensional code (Srivasta, 1980) for all test cases before the experiments were begun. Data and both previous and advanced model calculations are being compared as data are obtained.

Fuel-Injector/Air-Swirl Characterization

The objective of this study is to obtain fully-specified mean and turbulence measurements of both gas and droplet phases downstream of a fuel injector and air swirler typical of those used in gas turbine combustion chambers.

The flowfield of interest is an axisymmetric particle-laden jet flow with and without confinement and co-annular swirling air flow. Approximately 30 cases are under test with both glass-bead particle-laden jets and liquid sprays, with various combination of swirl strengths and confinement (Turbine Engine Hot Section Technology, 1985, 1986, 1987). Measurements of mean and turbulence quantities, for both gas and solid phases are being made using a 2-component Phase/Doppler LDV particle analyzer (McDonnell et al., 1987).

Calculations were performed for all test cases with a two-dimensional TEACH-type nonreacting turbulent viscous two-phase flow code before the experiments were begun. Data and both previous and advanced model calculations are being compared as data are obtained (Mostafa et al., 1987, 1988; Nikjooy et al., 1988).

In the first series of tests, the developing regions of unconfined single and two-phase flows, with $105 \mu\text{m}$ glass beads, have been examined experimentally and analytically for particle-to-gas mass loadings of 0.2 and 1.0. Data and calculations for the latter are shown in Fig. 11. A two-component Phase/Doppler system was used to map the flowfield, including particle number density, and two orthogonal components of velocity for both phases.

Calculations are shown for both deterministic and stochastic treatments of the particles, using a two-phase $k-\epsilon$ model. Both treatments of the particles give the same gas-phase axial velocity profiles, however, the stochastic approach, which attempts to model particle/gas phase interactions, gives better agreement for particle quantities than the deterministic approach which ignores turbulence interactions.

Another experimental program was conducted to obtain information on the characteristics of the spray produced by a gas turbine fuel injector (McVey et al., 1988a, 1988b). The objective of this study was to obtain spatially-resolved information on both the liquid and gaseous phases of the spray flow field under conditions of high-flow, high velocity, and high swirl that are typical of engine operation. Measurements

were made with a high-resolution spray patternator, a two-component laser velocimeter, and a single-component Phase/Doppler particle analyzer.

The comprehensive experimental data generated in these programs will be used to validate advanced models of turbulence, scalar, and spray transport, including two-equation turbulence models, algebraic and differential Reynolds stress models, scalar and scalar-velocity transport models, and Eulerian and Lagrangian deterministic and stochastic spray models.

SUMMARY

Although significant progress has been made in the development of three-dimensional analytical CFD codes and their application in future gas turbine combustor design, these codes are neither sufficiently comprehensive nor quantitatively accurate enough to permit a complete design alone. They are, however, a valuable component in an evolving combustor design methodology in which their capability is integrated with the substantial base of empirical experience and one-dimensional flow modeling.

CONCLUDING REMARKS

The NASA HOST sponsored Aerothermal Modeling Phase II programs will lead to significant improvements in our technical ability to predict nonreacting gas turbine combustor flow fields with and without spray injection. Significantly enhanced capabilities for accurately predicting combustor aerothermal performance and wall temperature levels and gradients will require further improvements in numerical schemes and physical submodels. It is equally important to collect fully-specified reacting flow data, similar to what is being done for nonreacting flows under HOST Phase II, for both complex constituent flows, and generic gas turbine combustors.

In parallel, work should continue in the formulation and systematic validation of turbulent combustion models for reacting sprays and multidimensional heat transfer models. These capabilities will provide the tools needed to analytically conduct the combustion trade-off studies so that optimum future combustion systems can be designed, fabricated, and developed within acceptable cost and schedule constraints.

REFERENCES

- Bruce, T.W., Mongia, H.C., and Reynolds, R.S., 1979, "Combustor Design Criteria Validation, Vol. I - Element Tests and Model Validation," USARTL-TR-78-551, (Avail. NITS, AD-A067657).
- Ferrell, G.B., and Lilley, D.G., 1985, "Deflected Jet Experiments in a Turbulent Combustor Flowfield," NASA CR-174863.
- Holdeman, J.E., Srinivasan, R., and Berenfeld, A., 1984, "Experiments in Dilution Jet Mixing," AIAA Journal, Vol. 22, no. 10, pp. 1436-1443.
- Holdeman, J.D., and Srinivasan, R., 1986, "Modeling Dilution Jet Flowfields," Journal of Propulsion and Power, Vol. 2, No. 1, pp. 4-10.
- Holdeman, J.D., Srinivasan, R., Coleman, E.B., Meyers, G.D., and White, C.D., 1987, "Effects of Multiple Rows and Noncircular Orifices on Dilution Jet Mixing," Journal of Propulsion and Power, Vol. 3, No. 3, pp. 219-226.
- Holdeman, J.D., Reynolds, R., and White, C., 1987, "A Numerical Study of the Effects of Curvature and Convergence on Dilution Jet Mixing," AIAA Paper 87-1953.
- Johnson, B.V., and Bennett, J.C., 1981, "Mass and Momentum Turbulent Transport Experiments with Confined Coaxial Jets," NASA CR-165574.
- Johnson, B.V., Roback, R., and Bennett, J.C., 1984, "Scalar and Momentum Turbulent Transport Experiments with Swirling and Nonswirling Flows," Experimental Measurements and Techniques in Turbulent Reactive and Non-Reactive Flows, R.M.C. So, J.H. Whitlaw, and M. Sapp, eds., ASME, New York, pp. 107-119.
- Kenworthy, M.J., Correa, S.M., and Burrus, D.L., 1983, "Aerothermal Modeling: Phase I Final Report - Volume 1 Model Assessment," NASA CR-168296.
- Lebfevre, A.H., 1985, "Influence of Fuel Properties of Gas Turbine Combustor Performance," AFWAL-TR-84-1104, (Avail. NTIS, AD-A151464).
- Lilley, D.G., 1986, "Lateral Jet Injection into Typical Combustor Flowfields," NASA CR-3997.
- McDonnell, V.G., Cameron, C.D., and Samuelsen, G.S., 1987, "Symmetry Assessment of a Gas Turbine Air-Blast Atomizer," AIAA Paper 87-2136.
- McMurry, C.B., and Lilley, D.B., 1986, "Experiments on Two Opposed Lateral Jets Injected Into Swirling Crossflow," NASA CR-175041.
- McVey, J.B., Kennedy, J.B., Russell, S., 1988, "Fuel-Injector/Air-Swirl Characterization Final Report," United Technologies Research Laboratories, United Technologies Research Center, NASA CR-180864.
- McVey, J.B., Kennedy, J.B., Russell, S., 1988, "Application of Advanced Diagnostics to Airblast Injector Flows," to be presented at the 33rd International Aeroengine and Gas Turbine Congress, Amsterdam, the Netherlands.
- Mongia, H.C., and Smith, K.G., 1978, "An Empirical/Analytical Design Methodology for Gas Turbine Combustors," AIAA Paper 78-998.
- Mongia, H.C., Reynolds, R.S., Coleman, E., and Bruce, T.W., 1979, "Combustor Design Criteria Validation, Volume II - Development Testing of Two Full-Scale Annular Gas Turbine Combustors," USARTL-TR-78-55B-VOL-2. (Avail. NTIS, AD-A067689).
- Mongia, H.C., and Reynolds, R.S., 1979, "Combustor Design Criteria Validation," Volume III - User's Manual," USARTL-TR-8-55C-VOL-3. (Avail. NTIS, AD-A066793).
- Mongia, H.C., Reynolds, R.S., and Srinivasan, R., 1986, "Multidimensional Gas Turbine Combustion Modeling: Applications and Limitations," AIAA Journal, Vol. 24, no. 6, pp. 890-904.
- Mongia, H., C., 1987, "A Status Report on Gas Turbine Combustor Modeling," presented at the AGARD Combustion and Fuels in Gas Turbine Engines Meeting, Crete, Oct. 12-16.

- Mostafa, A.A., Mongia, H.C., McDonell, V.G., and Samuelsen, G.S., 1987, "On the Evolution of Particle-Laden Jet Flows: A Theoretical and Experimental Study," AIAA Paper 87-2181.
- Mostafa, A.A., Mongia, H.C., McDonell, V.G., and Samuelsen, G.S., 1988, "On the Evolution of Particle-Laden Coaxial Jet Flows: A Theoretical and Experimental Study," AIAA Paper 88-0239.
- Nikjooy, M., Karki, K.C., Mongia, H.C., McDonell, V.G., and Samuelsen, G.S. 1988, "K-E Turbulence Model Assessment with Reduced Numerical Diffusion for Coaxial Jets," AIAA Paper 88-0342.
- Ong, L.H., and Lilley, D.G., 1986, "Measurements of a Single Lateral Jet Injected into Swirling Crossflow," NASA CR-175040.
- Patankar, S.W., Karki, K.C., and Mongia, H.C., 1987, "Development and Evaluation of Improved Numerical Schemes for Recirculating Flows, AIAA Paper 87-0061.
- Plee, S.L., and Mellor, A.M., 1979, "Characteristics Time Correlation for Lean Blowoff of Bluff-body Stabilized Flames," Combustion and Flame, Vol. 35, pp. 61-80.
- Reynolds, R., and White, C., 1986, "Transition Mixing Study Final Report," NASA CR-175062.
- Rizk, N.K., and Mongia, H.C., 1986, "Gas Turbine Design Methodology," AIAA Paper 86-1513.
- Roback, R., and Johnson, B.V., 1983, "Mass and Momentum Turbulent Transport Experiments with Confined Coaxial Jets," NASA CR-168252.
- Runchal, Aksai, K., Anand, M.S., and Mongia, H.C., 1987, "An Unconditionally-Stable Central Differencing Scheme for High Reynolds Number Flows. AIAA Paper 87-0060.
- Sokolowski, D. E., and Ensign, C. R., 1986, "Toward Improved Durability in Advanced Combustors and Turbines - Progress in the Prediction of Aerothermal Loads," ASME Paper 86-GT-172. (NASA TM-88932),
- Srinivasan, R., and Mongia, H.C., 1980, "Numerical Computations of Swirling Recirculating Flow Final Report," NASA CR-165196.
- Srinivasan, R., Berenfeld, A., and Mongia, H.C., 1982, "Dilution Jet Mixing Program: Phase I Report," NASA CR-168031.
- Srinivasan, R., Reynolds, R., Ball, I., Berry, R., Johnson, K., and Mongia, H., 1983, "Aerothermal Modeling Program: Phase I Final Report - Volume I," NASA CR-168243.
- Srinivasan, R., Reynolds, R., Ball, I., Berry, R., Johnson, K., and Mongia, H., 1983, "Aerothermal Modeling Program: Phase I Final Report - Volume II," NASA CR-168243.
- Srinivasan, R., Coleman, E., and Johnson, K., 1984, "Dilution Jet Mixing Program: Phase II Report," NASA CR-174624.
- Srinivasan, R., Meyers, G., Coleman, E., and White, C., 1985, "Dilution Jet Mixing Program: Phase III Report." NASA CR-174884.
- Srinivasan, R., and White, C., 1986, "Dilution Jet Mixing Program: Supplementary Report," NASA CR-175043.
- Srinivasan, R., and Thorp, D.J., 1987, "Combustor Diffuser Interaction Program," AFWAL-TR-86-2093, Air Force Wright Aeronautical Labs, Wright Patterson AFB, OH.
- Srivatsa, S.K., 1982, "Computations of Soot and NO_x Emissions from Gas Turbine Combustors," NASA CR-165196.
- Sturgess, Geoffrey J., 1983, "Aerothermal Modeling: Phase I Final Report," NASA CR-168202.
- Sullivan, R.E., Young, E.R., Miles, G.A., Williams, J.R., 1983, "Small Gas Turbine Combustor Primary Zone Study," NASA CR-168122.
- Syed, S.A., Chiappetta, L.M., and Gosman, A.D., 1985, "Error Reduction Program," NASA CR-174776.
- Turan, A., and VanDoormal, J.P., 1987, "Improved Numerical Methods for Turbulent Viscous Recirculation Flows," NASA CR-180852.
- Turbine Engine Hot Section Technology (HOST) 1982 NASA TM-83022.
- Turbine Engine Hot Section Technology 1983, NASA CP-2289.
- Turbine Engine Hot Section Technology 1984, NASA CP-2339.
- Turbine Engine Hot Section Technology 1985, NASA CP-2405.
- Turbine Engine Hot Section Technology 1986, NASA CP-2444.
- Turbine Engine Hot Section Technology 1987, NASA CP-2493.
- Vanka, S.P., 1987, "Block-Implicit Computation of Viscous Internal Flows - Recent Results," AIAA Paper 87-0058.

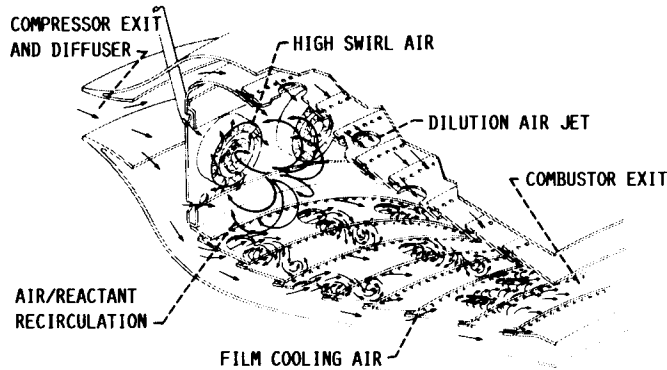

- FULLY 3-DIMENSIONAL FLOW
- CHEMICAL REACTION/HEAT RELEASE
- HIGH TURBULENCE LEVELS
- 2 PHASE WITH VAPORIZATION

FIGURE 1. - COMBUSTOR FLOW PHENOMENA.

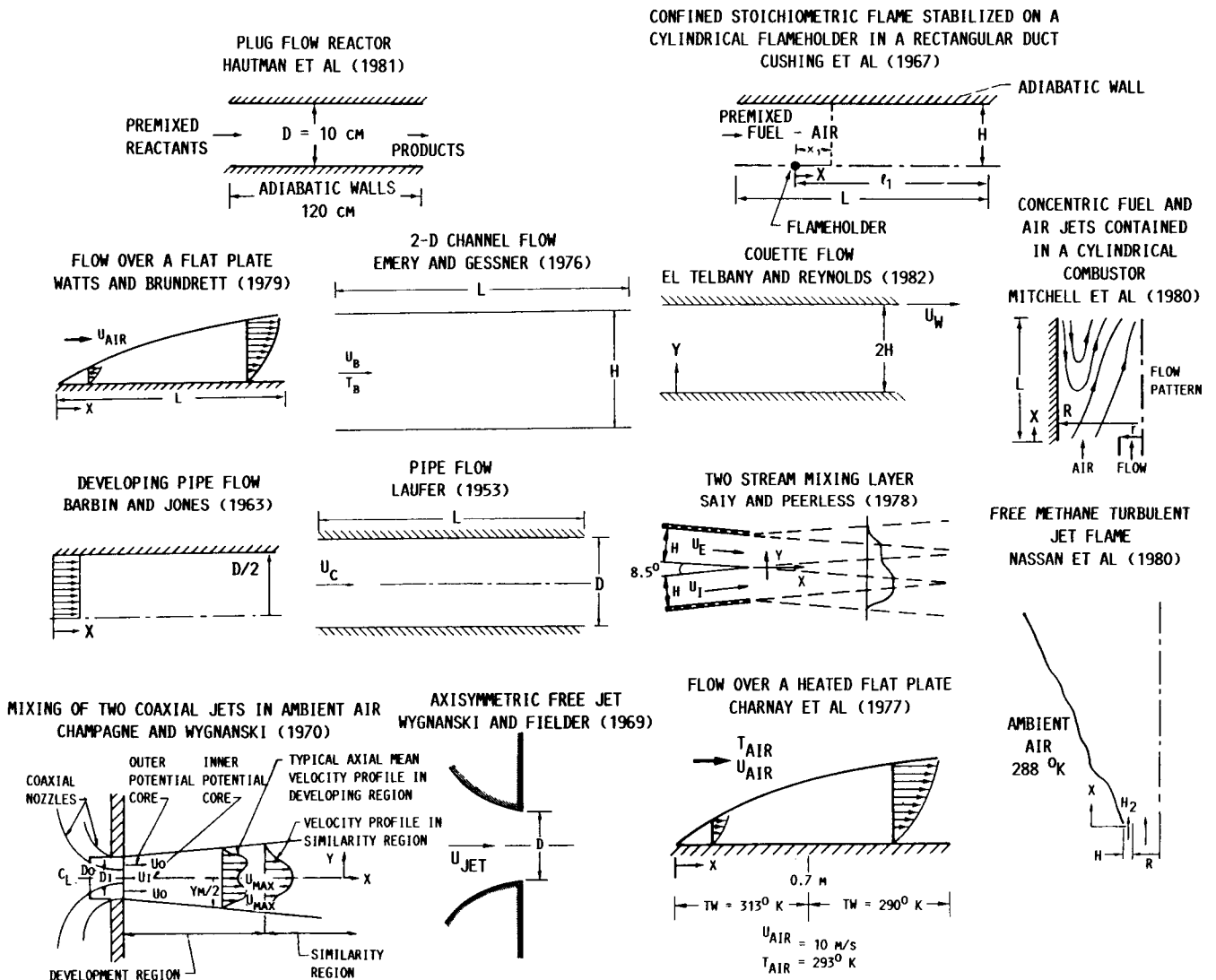

(A) SIMPLE FLOWS.

FIGURE 2. - FLOWS FOR WHICH ANALYTICAL MODEL CALCULATIONS WERE PERFORMED IN SRINIVASAN ET AL. (1983)

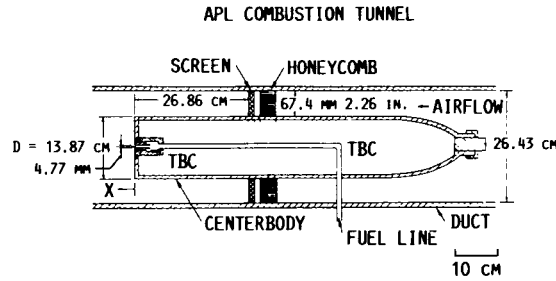

FLOW IN A CURVED CHANNEL
SHIVA PRASAD AND RAMA PRIYAN (1978)

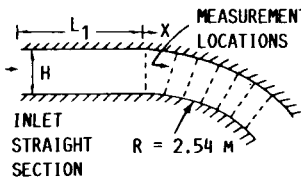

FLOW OVER A BACKWARD FACING PLANE STEP
KIM, KLINE, AND JOHNSTON (1978) AND EATON AND JOHNSTON (1980)

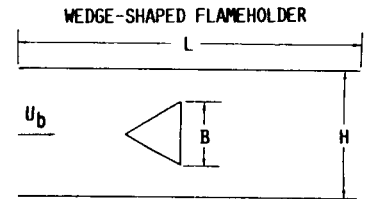
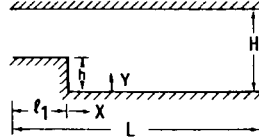

FLOW OVER A RING IN A PIPE
PHATARAPHRUK AND LOGAN (1979)

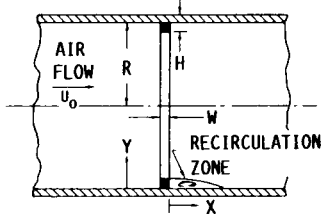

SUDDEN PIPE-EXPANSION
MOON AND RUDINGER (1977)



FLOW THROUGH A SUDDEN EXPANSION IN A PIPE
JOHNSON AND BENNETT (1981)

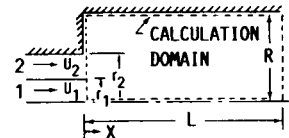

OPPOSED JET COMBUSTOR
SCHEFFER AND SAWYER (1976)

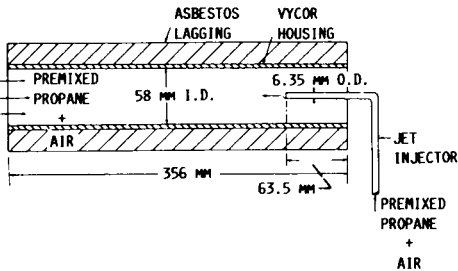

AXISYMMETRIC COMBUSTOR WITH COAXIAL FUEL AND AIR JETS
LEWIS AND SMOOT (1973)

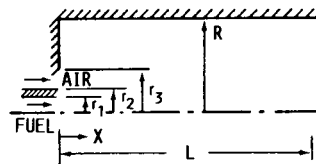

FLOW BEHIND A BACKWARD FACING STEP
PITZ AND DAILY (1981)

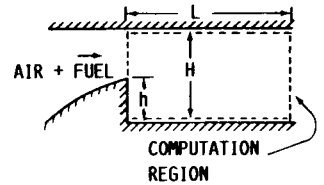

(B) COMPLEX NONSWIRLING FLOWS.

FIGURE 2. - CONTINUED.

TWO COAXIAL JETS IN STAGNANT AIR
MORSE (1980)

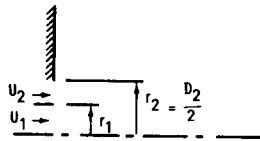

SWIRL COMBUSTOR WITH COOLING AIR
BRUM AND SAMUELSEN (1982)

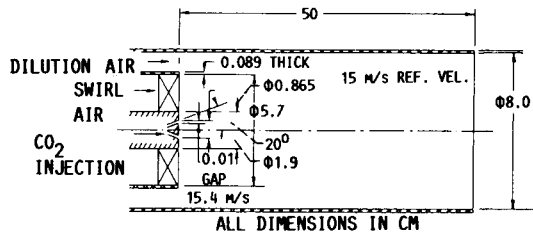

CONFINED SWIRL-DRIVEN FLOW
ALTGELD, ET AL (1983)

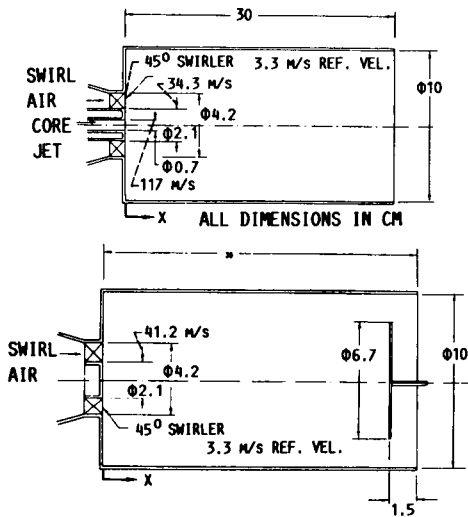

CYLINDRICAL COMBUSTOR WITH ROTATING CUP
ATOMIZER AND AIR INTRODUCED THROUGH A SWIRLER
SURROUNDING THE ATOMIZER
EL-BANHAWY AND WHITELAW (1981)

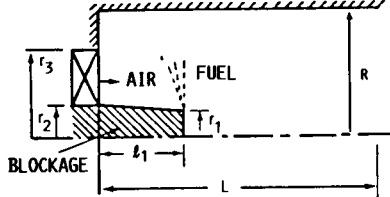

SWIRLING FLOW IN A PIPE EXPANSION
JANJUA ET AL (1982)

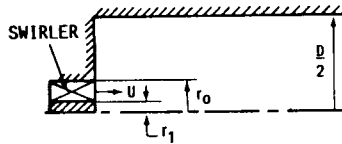

(C) SWIRLING FLOWS.

FIGURE 2. - CONCLUDED.

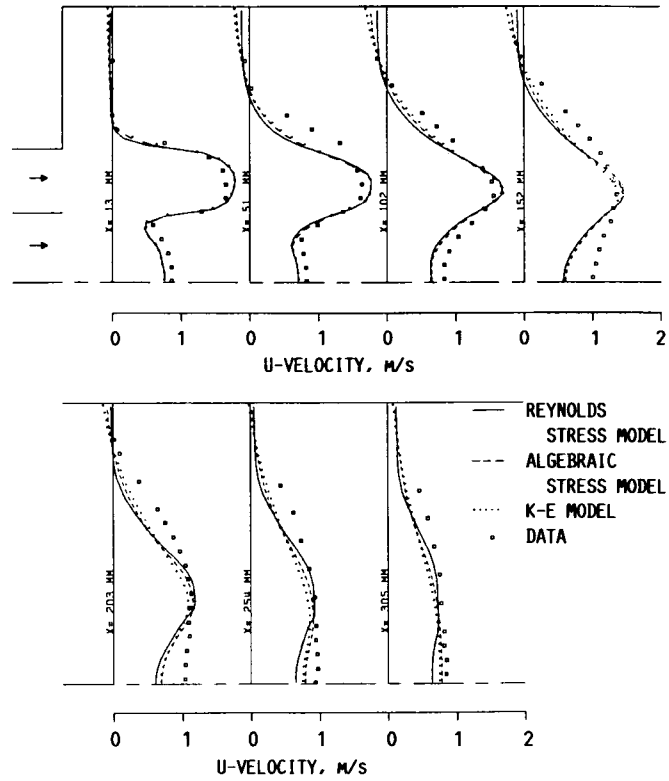

FIGURE 3. - COMPARISON OF MEASURED MEAN AXIAL VELOCITY PROFILES FOR COANNULAR JETS DOWNSTREAM OF AN AXISYMMETRIC SUDDEN EXPANSION, WITH CALCULATIONS MADE USING THREE TURBULENCE MODELS.

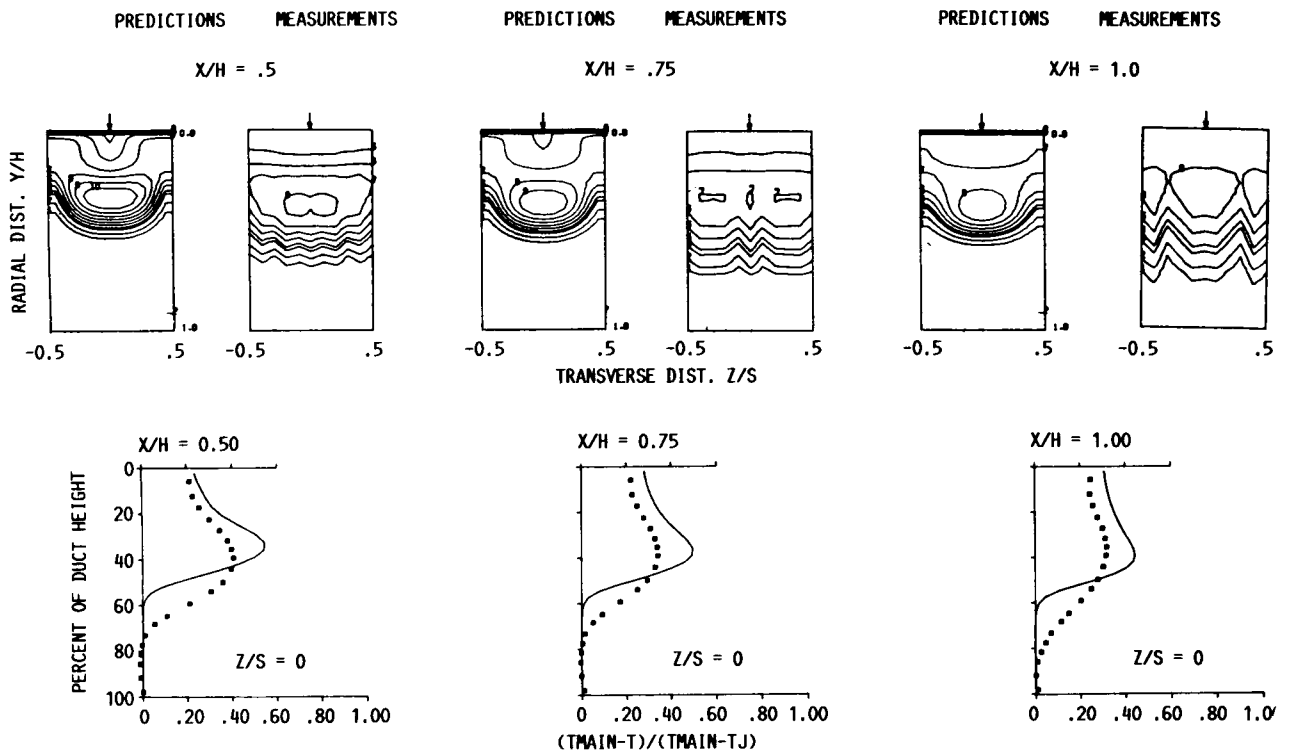

FIGURE 4. - COMPARISON BETWEEN MEASURED AND CALCULATED DIMENSIONLESS TEMPERATURE DIFFERENCE RATIOS DOWNSTREAM FROM A ROW OF COOL JETS INJECTED INTO A CONSTANT-TEMPERATURE CROSS FLOW FROM THE UPPER WALL OF A CONSTANT AREA DUCT ($J = 25.32$, $S/H = 0.25$, $H/D = 8$, 19 890 NODES).

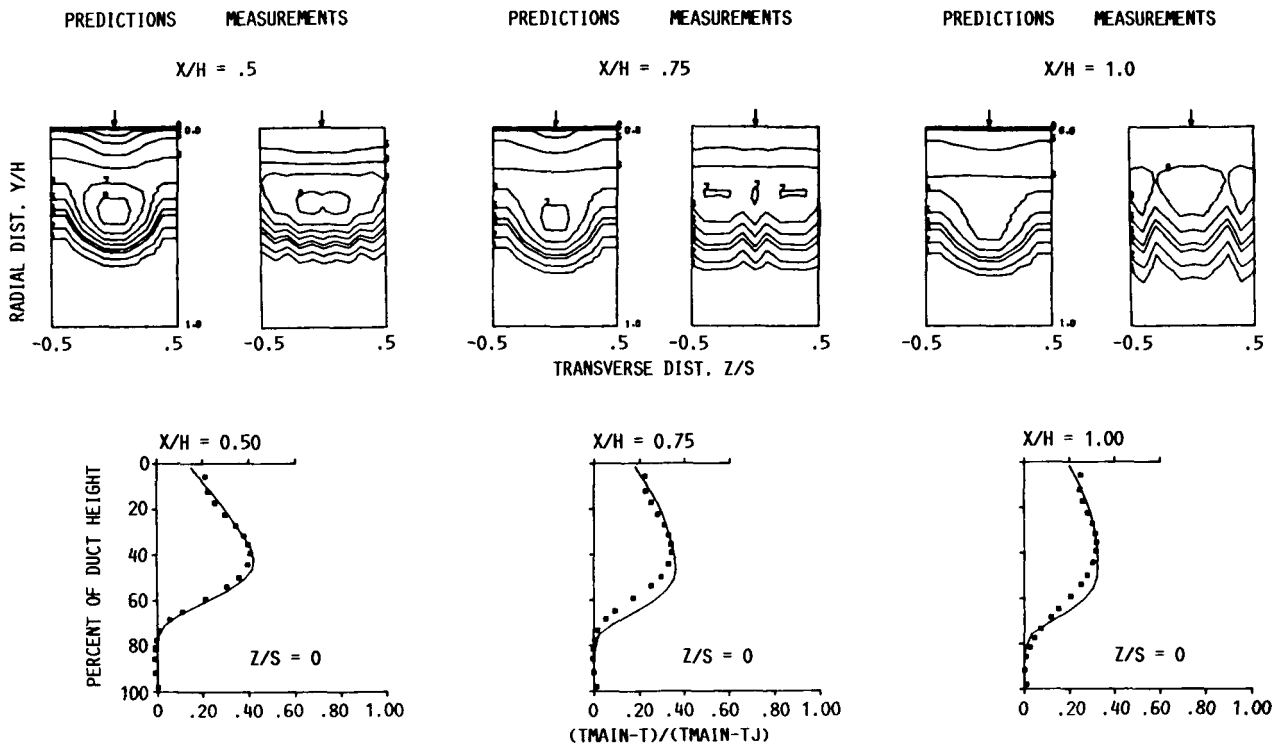
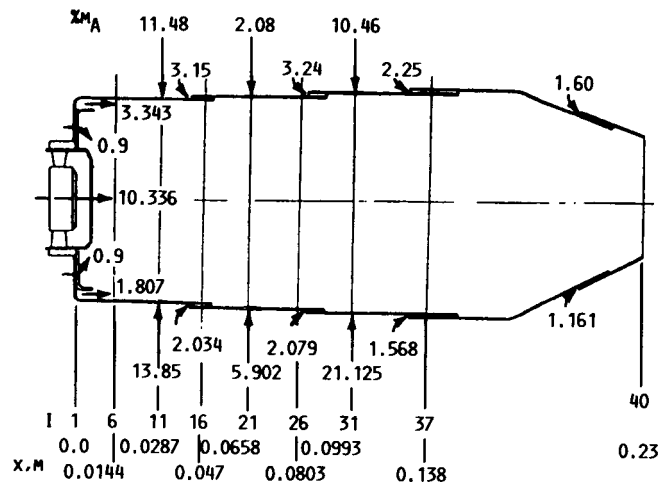
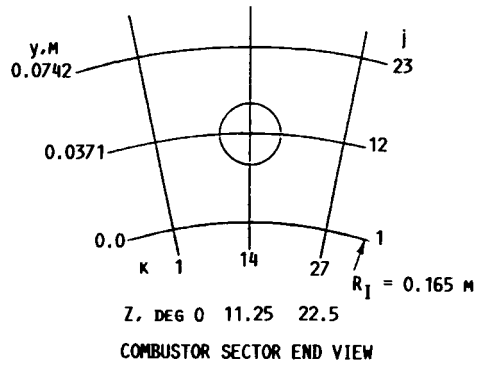
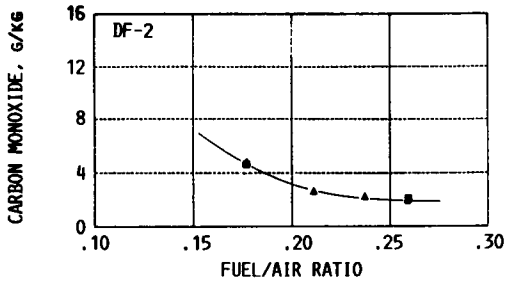

FIGURE 5. - COMPARISON BETWEEN MEASURED AND CALCULATED DIMENSIONLESS TEMPERATURE DIFFERENCE RATIOS DOWNSTREAM FROM A ROW OF COOL JETS INJECTED INTO A CONSTANT-TEMPERATURE CROSS FLOW FROM THE UPPER WALL OF A CONSTANT AREA DUCT ($J = 25.32$, $S/H = 0.25$, $H/D = 8$, 5615 NODES).



MAXIMUM POWER
 $\dot{M}_A = 15.768 \text{ KG/S}$
 $P_3 = 1085.3 \text{ KPA}$
 $T_3 = 609.4 \text{ K}$
 $FAR = 0.0225$

FIGURE 6. - ANNULAR COMBUSTOR SCHEMATIC AND CALCULATION GRID CONFIGURATION.



(A) CARBON MONOXIDE.

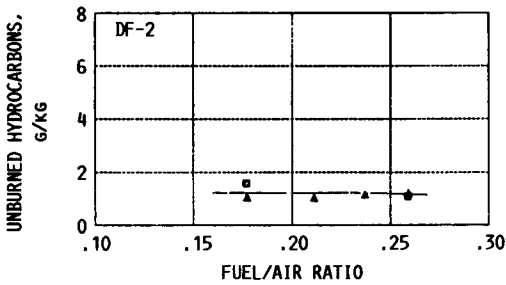

(B) UNBURNED HYDROCARBONS.

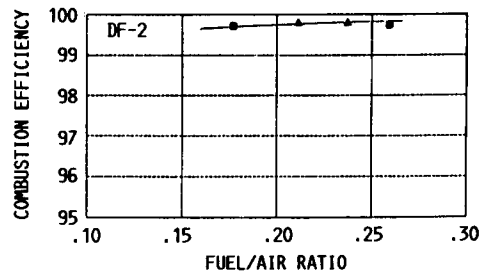

(E) COMBUSTION EFFICIENCY.

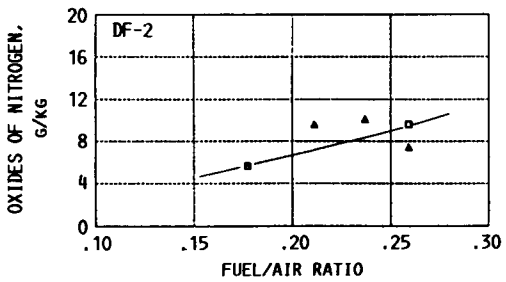

(C) OXIDES OF NITROGEN.

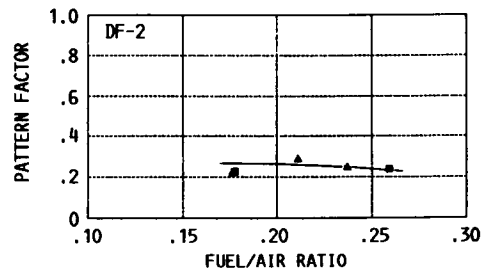

(F) EXIT TEMPERATURE PATTERN FACTOR.

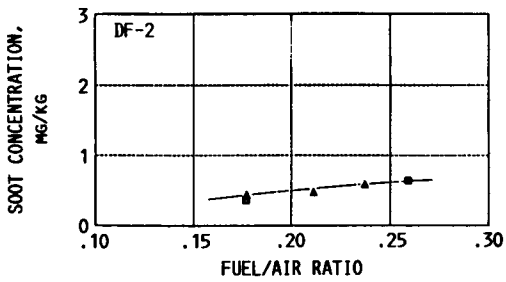

(D) SOOT.

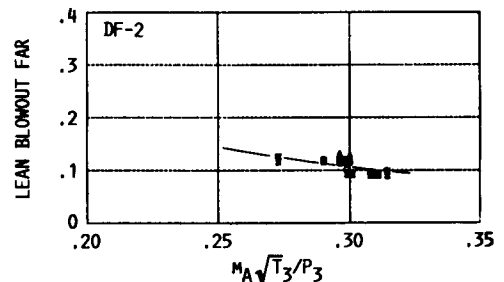

(G) LEAN BLOWOUT CHARACTERISTICS.

FIGURE 7. - COMPARISON OF MEASURED AND PREDICTED PERFORMANCE AND EMISSIONS FOR COMBUSTOR IN FIG. 6.

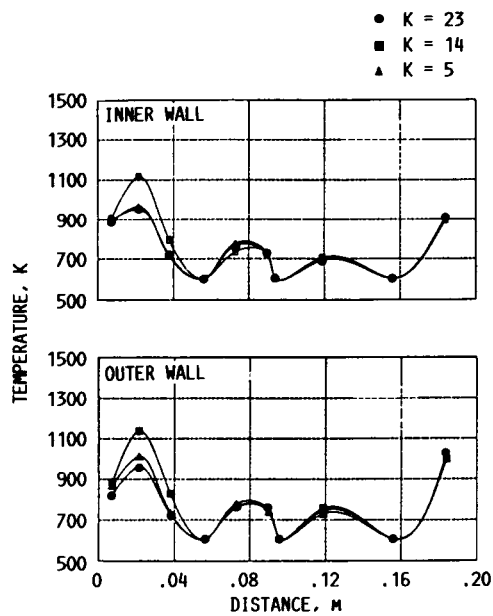
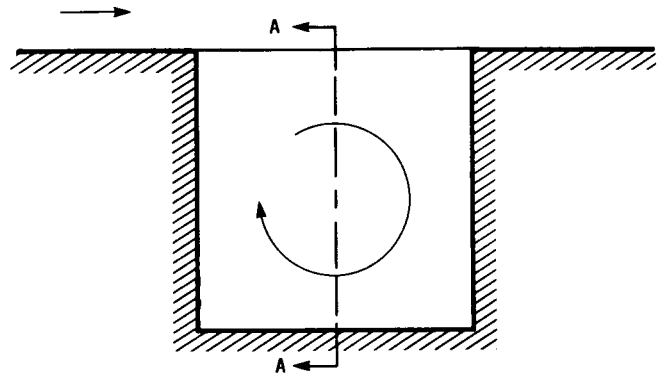
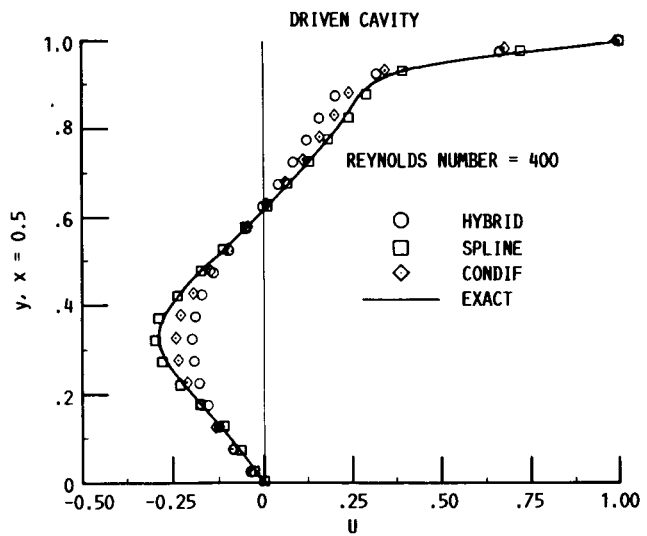

FIGURE 8. - CALCULATED LINER WALL TEMPERATURES AT MAXIMUM POWER CONDITION FOR COMBUSTOR IN FIG. 6.



(A) FLOW SCHEMATIC.



(B) VELOCITY PROFILES AT SECTION A-A.

FIGURE 9. - CALCULATIONS OF LAMINAR FLOW IN A SQUARE (2-D) DRIVEN CAVITY.

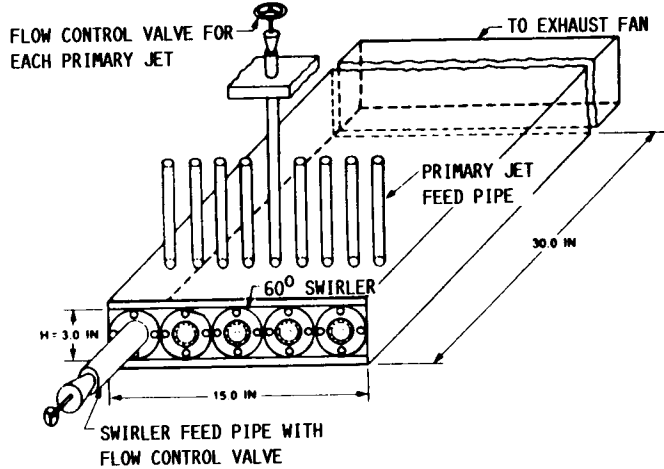

FIGURE 10. - TEST SECTION GEOMETRY FOR EXPERIMENTAL STUDY OF INTERACTION BETWEEN FLOW FROM MULTIPLE SWIRLERS AND TRANSVERSE JETS.

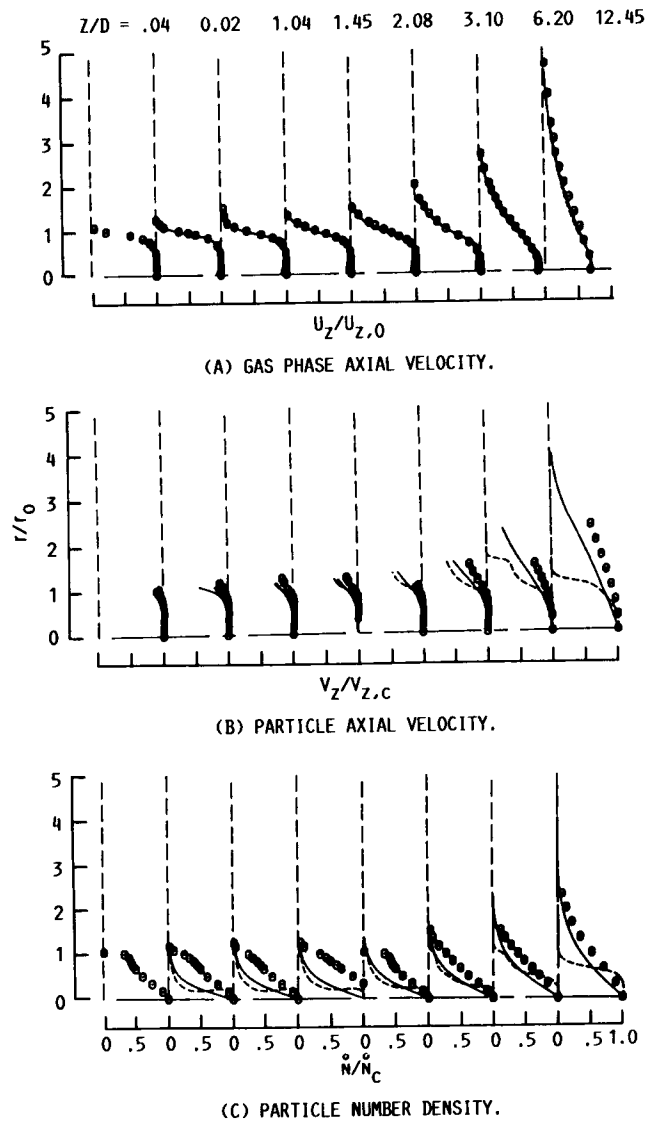

FIGURE 11. - RADIAL PROFILES OF GAS-AND SOLID-PHASE MEAN FLOW COMPONENTS AND PARTICLE NUMBER DENSITY AT A PARTICLE NUMBER DENSITY AT A PARTICLE-TO-GAS MASS LOADING RATIO OF 1.0.