

N89 - 21749

1988

NASA/ASEE SUMMER FACULTY FELLOWSHIP PROGRAM

**MARSHALL SPACE FLIGHT CENTER
THE UNIVERSITY OF ALABAMA**

**SIMULATION OF WATER VAPOR CONDENSATION ON
LOX DROPLET SURFACE USING LIQUID NITROGEN**

Prepared by:	Eugene A. Powell
Academic Rank:	Senior Research Engineer
University and Department Engineering	Georgia Institute of Technology School of Aerospace
NASA/MSFC: Laboratory:	Propulsion
Division:	Propulsion Systems
Branch:	Performance Analysis
MSFC Colleague:	Richard Eskridge
Date:	September 2, 1988
Contract No.:	NGT 01-002-099 The University of Alabama

SIMULATION OF WATER VAPOR CONDENSATION ON LOX DROPLET SURFACE USING LIQUID NITROGEN

by

Eugene A. Powell
Senior Research Engineer
School of Aerospace Engineering
Georgia Institute of Technology
Atlanta, Georgia

ABSTRACT

This project was concerned with the formation of ice or water layers on liquid oxygen (LOX) droplets in the Space Shuttle Main Engine (SSME) environment. Formation of such ice/water layers is indicated by phase-equilibrium considerations under conditions of high partial pressure of water vapor (steam) and low LOX droplet temperature prevailing in the SSME preburner or main chamber. An experimental investigation was begun using liquid nitrogen as a LOX simulant. A monodisperse liquid nitrogen droplet generator was developed which uses an acoustic driver to force the stream of liquid emerging from a capillary tube to break up into a stream of regularly spaced uniformly sized spherical droplets. The atmospheric pressure liquid nitrogen in the droplet generator reservoir was cooled below its boiling point to prevent two phase flow from occurring in the capillary tube. The cooling was accomplished by a jacket of liquid nitrogen boiling at subatmospheric pressure. An existing steam chamber was modified for injection of liquid nitrogen droplets into atmospheric pressure superheated steam. The droplets were imaged using a stroboscopic video system and a laser shadowgraph system.

Several tests were conducted in which liquid nitrogen droplets were injected into the steam chamber. Under conditions of periodic droplet formation, images of 600 micron diameter liquid nitrogen droplets falling through the steam were obtained with the stroboscopic video system. These pictures showed trails of submicron sized ice and/or water particles in the wakes of the liquid nitrogen droplets, but were unable to show ice or water layers on the surfaces of the particles. The laser shadowgraphs showed density gradients in the wakes of the particles, which were due to temperature and composition gradients caused by mixing between the cold nitrogen vapors given off by the droplets and the steam in the chamber. Recommendations are made for future studies utilizing improved diagnostic techniques and injecting the droplets into a high pressure steam environment.

INTRODUCTION

The life history of liquid oxygen (LOX) droplets is of critical importance to the performance of the Space Shuttle Main Engine (SSME). In the operation of liquid propellant rocket engines, the burning rate has been shown to be controlled by the vaporization of propellant droplets formed soon after injection [1]. This evaporation process normally includes a period in which the droplet is heated from its injection temperature to a steady-state wet-bulb temperature. The wet-bulb temperature is characterized by the transformation of all heat reaching the droplet surface into latent heat of vaporization with no further increase in temperature of the liquid. For droplets in a high pressure environment, such in a rocket thrust chamber, the wet-bulb temperature may not be reached. Under these conditions the droplet heating rate will control the droplet lifetime [2,3]. Combustion of LOX in the SSME is such an example. The droplet evaporation history determines the spatial distribution of energy release rate and also controls the combustion efficiency of the rocket.

The primary tool used to calculate the performance of the SSME is the ARICC code developed by Rocketdyne [4], which contains a submodel for droplet evaporation. In this submodel, it is assumed that the droplet heating process is quasi-steady and that phase-equilibrium prevails on the droplet surface. Heat is convected from the ambient gas to the droplet surface and carried away from the droplet surface due to mass transfer. The major driving force for LOX droplet evaporation is due to the difference between the O₂ vapor pressure at the liquid surface and the ambient O₂ partial pressure. The gas temperature and partial pressure distribution of O₂ vapor near the droplet surface are assumed to be continuous. Temperature ranges from the surface temperature (about 100 K) to ambient temperature (about 3000 K), and O₂ vapor pressure ranges from its saturated vapor pressure corresponding to the droplet temperature to the ambient O₂ vapor pressure.

In the SSME environment, the main combustion product is water vapor, which is about 75 percent by molar fraction while the balance is mainly hydrogen. Therefore the H₂O vapor pressure at the

LOX droplet surface will be very high, in the neighborhood of 2000 psi. This pressure is much higher than the saturated H₂O vapor pressure of ice at the liquid O₂ temperature of 100 K. With such a low temperature at the O₂ surface and very high H₂O vapor pressure, the phase-equilibrium concept implies that water vapor will condense and freeze at the liquid O₂ surface. Thus it is probable that there will be a layer of ice and liquid water surrounding the O₂ droplet during a part of the LOX droplet life history. Such an ice/water layer would invalidate the droplet evaporation submodel used in the ARICC code. The ice/water layer would be expected to extend the droplet lifetime thus reducing the evaporation rate and consequently the burning rate. This would have an adverse effect on the SSME performance.

On the other hand, if H₂O does not condense at the liquid O₂ surface, it implies that phase-equilibrium does not exist. In this case, super-saturated H₂O vapor will exist around the droplet surface, and the droplet evaporation submodel used in the ARICC code will not be adequate since it is based upon phase-equilibrium assumptions.

The possibility of the formation of ice/water layers on the LOX droplets in the SSME preburner and thrust chambers needs experimental verification. The work described in this report is concerned with the detection of ice and water layers on droplets of a cryogenic simulant injected into a chamber containing superheated steam at atmospheric pressure. This represents a first step toward the development of a high pressure facility to investigate the formation of condensed phase layers on cryogenic propellant droplets under SSME chamber conditions. The major part of the work described herein is concerned with the design, construction, and testing of a cryogenic liquid droplet generator to produce drops of uniform size and spacing.

OBJECTIVES

The objectives of this work were to:

1. Design and construct a monodisperse droplet generator for the production of liquid nitrogen droplets of uniform size and spacing.
2. Modify an existing steam chamber for use in the investigation of the formation of ice/water layers on liquid nitrogen droplets.
3. Explore possible diagnostic techniques for the detection of the ice/water layers on the liquid nitrogen droplets.

DEVELOPMENT OF THE MONODISPERSE LIQUID NITROGEN DROPLET GENERATOR

Although the formation of ice and water layers on liquid oxygen (LOX) droplets is of concern in the performance of the SSME, a cryogenic simulant was used in these studies to avoid the combustion and explosion hazards of liquid oxygen. The simulant should be inexpensive and have a droplet temperature similar to that of liquid oxygen. Argon has an atmospheric pressure boiling temperature of 87.5 K [5], which is very close to that of liquid oxygen (90.2 K), but liquid argon is too expensive. Liquid nitrogen was chosen because it is inexpensive, readily available and easily handled, and its atmospheric boiling temperature of 77.4 K is sufficiently close to that of liquid oxygen.

The requirements for the production of monodisperse liquid nitrogen droplets in a single stream of evenly spaced droplets arose from the desirability of using stroboscopic imaging techniques to "freeze" the droplets. Such techniques have been successfully used by other investigators in the study of burning fuel droplets. It is expected that the stroboscopic imaging method will also be useful in the investigation of the formation of ice and liquid water layers on the surfaces of cryogenic propellant droplets.

A prototype monodisperse droplet generator, which worked well with noncryogenic fluids such as water or ethanol, was previously developed in the Combustion Physics Laboratory by Richard Eskridge. This generator consisted basically of a cylindrical reservoir which fed liquid to a capillary tube. By applying an acoustic pressure disturbance to the surface of the liquid in the reservoir (using a simple loudspeaker), the liquid jet issuing from the capillary tube could be forced to break up into a stream of evenly spaced spherical droplets of uniform diameter. The droplets are produced at the rate of one for every cycle of oscillation of the acoustic pressure. In the absence of acoustic excitation, the stream still breaks up into droplets, but the drops are not uniform in size or regularly spaced. With acoustic driving the droplet formation process is periodic, without acoustic driving the droplet formation process is generally chaotic.

Attempts to produce liquid nitrogen droplets with this prototype droplet generator were unsuccessful due to two phase flow in the capillary tube. Due to excessive heat transfer from the environment, the liquid nitrogen in the capillary tube vaporized and caused the production of any droplets to be very intermittent and chaotic. Thus the droplet generator needed to be redesigned to minimize heat transfer to the liquid nitrogen both in the reservoir and the capillary tube.

A new droplet generator was designed and constructed in attempt to eliminate the two phase problem. A diagram of this apparatus and the associated acoustic driving and stroboscopic imaging systems are shown in Figure 1. The liquid nitrogen reservoir consists of a copper sphere about 20 cm in diameter with a capacity of approximately 4 liters. The sphere is insulated with a 25 mm thick layer of fiberglass wool and covered with aluminum tape.

ORIGINAL PAGE IS
OF POOR QUALITY

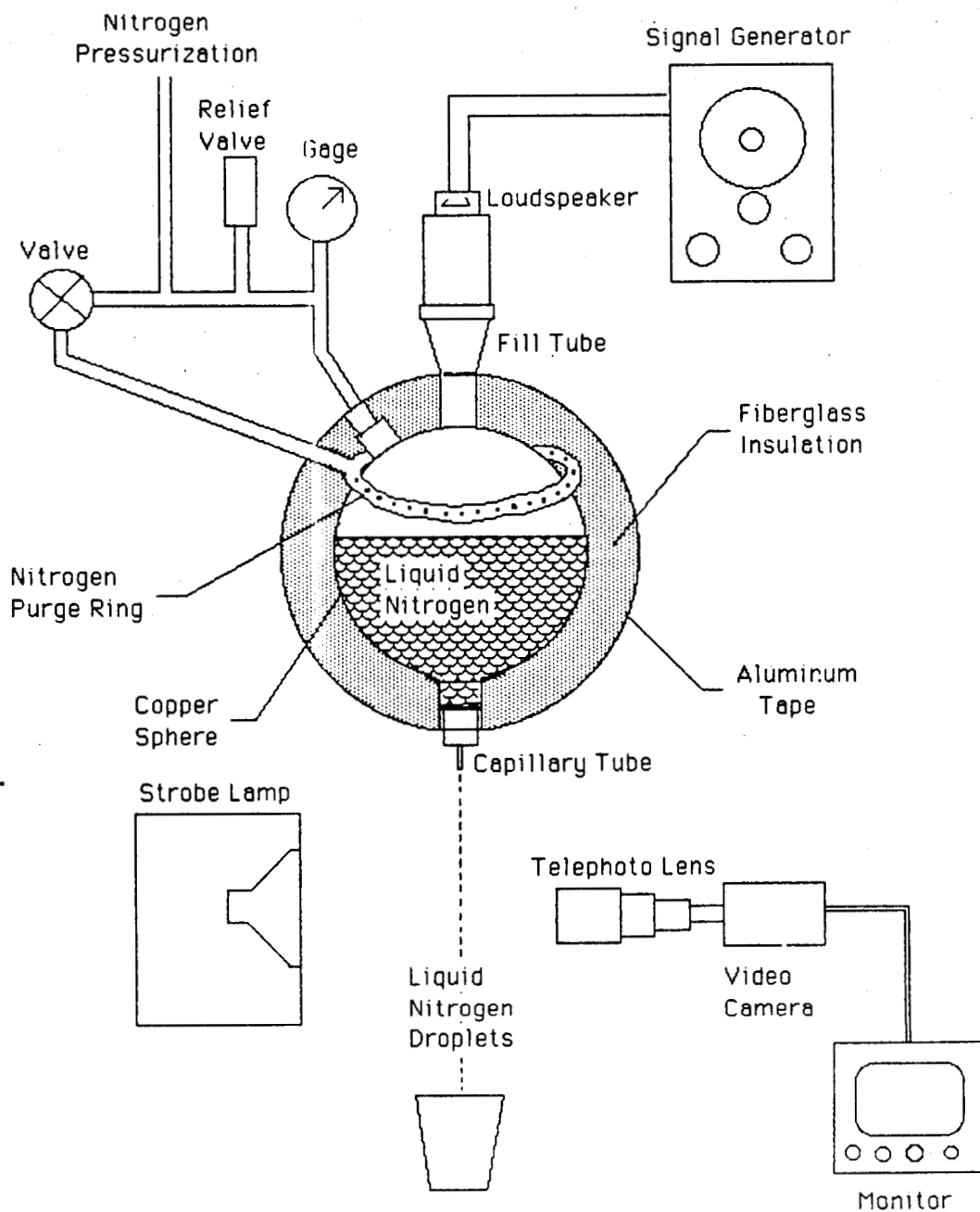

Figure 1. Liquid Nitrogen Droplet Generator, First Design

To prevent moisture from the air from condensing in the fiberglass insulation, a dry nitrogen purge is provided through a perforated ring of copper tubing embedded in the insulation. The nitrogen for this purge system is provided by boiloff vapor from the spherical reservoir. The reservoir is filled through a funnel-like galvanized iron pipe fitting at the top. A standard PVC pipe fitting containing the loudspeaker is screwed into the top of the galvanized fitting after the reservoir is filled. The droplet stream emerges from the bottom of the reservoir through either a stainless steel or glass capillary tube. The reservoir is provided with nitrogen gas pressurization in order to control the flow rate from the capillary tube.

The stroboscopic imaging system is also shown in Figure 1. The droplet stream is illuminated by a neon strobe lamp from behind, and the droplets are imaged using an extended telephoto lens on a video camera. The strobe light is synchronized with the framing rate of the video monitor. In order to obtain stroboscopic imaging of the droplets, the droplet generation frequency must be an integer multiple of the strobe frequency. For this system the loudspeaker output is sufficient to drive droplet formation for a frequency range of about 300 Hz to about 1200 Hz, while the video monitor framing rate is about 30 Hz. Therefore the droplet generation frequency ranges from about 10 to about 40 times the strobe frequency. Thus the acoustically driven droplet formation process must be very stable and the droplet stream must be protected from external disturbances such as air currents in order to obtain good stroboscopically frozen images.

Several tests of the droplet generator were conducted using water or ethanol as the fluid. In these tests acoustically driven periodic droplet formation and good stroboscopic imaging were obtained for several driving frequencies. Several operating characteristics were noted. By varying the nitrogen pressurization of the reservoir, the flow rate and hence the velocity of the fluid stream emerging from the capillary tube could be varied. Periodic droplet formation was sensitive to the velocity of the droplet stream. If the velocity was too low chaotic droplet formation prevailed. If the velocity was too high, the droplets were nonspherical and oscillated excessively. Under high velocity conditions small satellite droplets were also obtained. For a given acoustic driving frequency the spacing of the droplets increased as the liquid jet velocity increased.

Tests conducted with liquid nitrogen were unsuccessful in producing acoustically driven periodic droplet formation. The basic problem appeared to be boiling of the liquid nitrogen in the spherical reservoir and two phase flow in the capillary tube. Boiling in the reservoir may cause random disturbances to the droplet stream, and vapor bubbles in the reservoir are expected to damp the acoustic oscillations. Furthermore vapor bubbles entrained into the liquid flow through the capillary tube caused the liquid jet to be intermittent, a phenomenon which was easily seen using the imaging system. The results of these tests indicated that further measures are required in order to obtain acoustically driven periodic droplet formation with liquid nitrogen or other cryogenic fluids. In particular these measures must eliminate boiling in the liquid nitrogen reservoir and two phase flow in the capillary tube.

To prevent the liquid nitrogen in the droplet reservoir from boiling, it is necessary to cool it below its atmospheric boiling point of 77.4 K. This can be done by immersing the droplet reservoir in a low temperature bath obtained by boiling liquid nitrogen at subatmospheric pressure. The vapor pressure of liquid nitrogen as a function of temperature is given in Figure 2 [6]. In the absence of active refrigeration, cryogenic fluids such as liquid nitrogen always exist at their boiling point as a result of heat transfer from their surroundings. As Figure 2 shows, however, this boiling temperature can be lowered by reducing the pressure above the liquid. For example if liquid nitrogen is initially boiling at atmospheric pressure and the pressure is then reduced to approximately 0.5 atmosphere, the liquid will cool to a new boiling temperature of 72 K. During this cooling process an amount of liquid must be vaporized as determined by equating the latent heat of vaporization to the heat extracted from the remaining liquid during the cooling process. In principle a bath temperature as low as 64 K can be obtained by boiling liquid nitrogen at a pressure of about 0.15 atmosphere. For pressures below 0.12 atmosphere (the triple point of nitrogen), formation of solid nitrogen occurs.

Before designing a new monodisperse droplet generator using the subatmospheric nitrogen bath, a simple experiment was conducted to demonstrate the feasibility of this method. The apparatus for this experiment is shown in Figure 3. A 1000 ml Nalgene Erlenmeyer flask was nearly filled with liquid nitrogen, and a Pyrex glass bulb (50 ml capacity) was inserted into the liquid nitrogen bath. A side tube in the neck of the Erlenmeyer flask was connected by plastic tubing to a vacuum pump. About 40 ml of liquid nitrogen was then introduced into the glass bulb. One end of a length of plastic tubing was connected to the neck of the glass bulb, and the other end was submerged in a beaker of water. The boiling of the liquid nitrogen in the glass bulb could then be detected by the vapor bubbles emerging from the submerged tube. With the vacuum line disconnected, both the flask and the bulb were at atmospheric pressure and vigorous boiling occurred due to heat transfer from the environment.

When the vacuum pump was connected and turned on, the pressure in the flask dropped quickly to about 0.67 atmosphere, and boiling in the bulb ceased almost immediately. As the pressure in the flask gradually reached a steady state value of about 0.27 atmosphere, water was drawn up into the indicator tube. This was caused by nitrogen gas condensing in the glass bulb, thus reducing the pressure slightly below ambient pressure. This steady state condition was maintained for several minutes while the subatmospheric liquid nitrogen continued to boil. The temperature of the liquid nitrogen boiling at 0.27 atmosphere was about 67.7 K (Figure 2), which is 9.7 K below the atmospheric boiling point. At the end of the experiment the vacuum pump was shut off and the glass bulb was quickly removed and observed. The bulb was clear (no moisture was in the Erlenmeyer flask) allowing the liquid nitrogen in the bulb to be seen. The bulb still contained nearly 40 ml of liquid nitrogen which was not boiling. Shortly thereafter the bulb frosted over and vigorous boiling took place.

A new monodisperse liquid nitrogen droplet generator was designed and constructed using a cooling jacket of subatmospheric pressure liquid nitrogen.

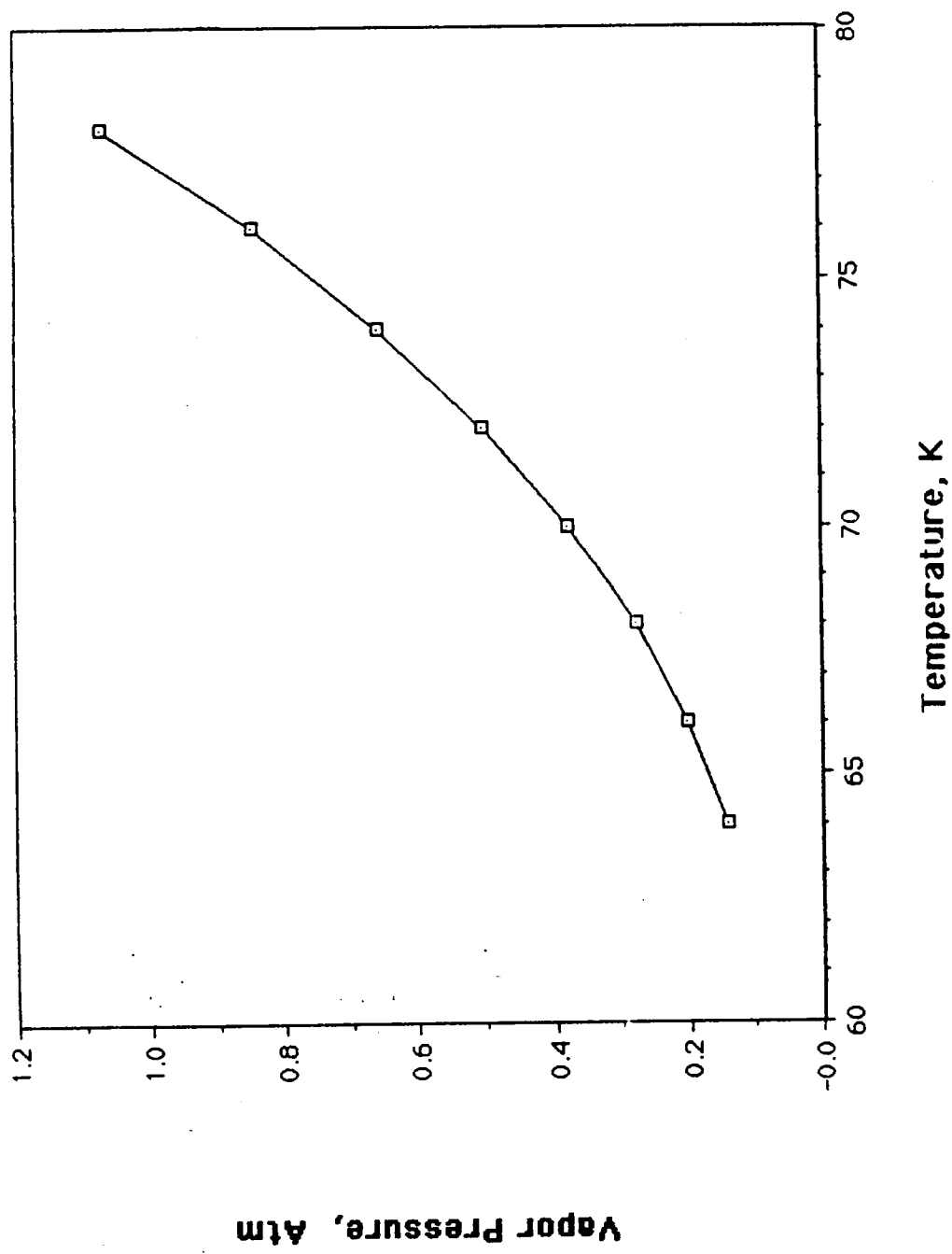

Figure 2. Vapor Pressure of Liquid Nitrogen vs Temperature

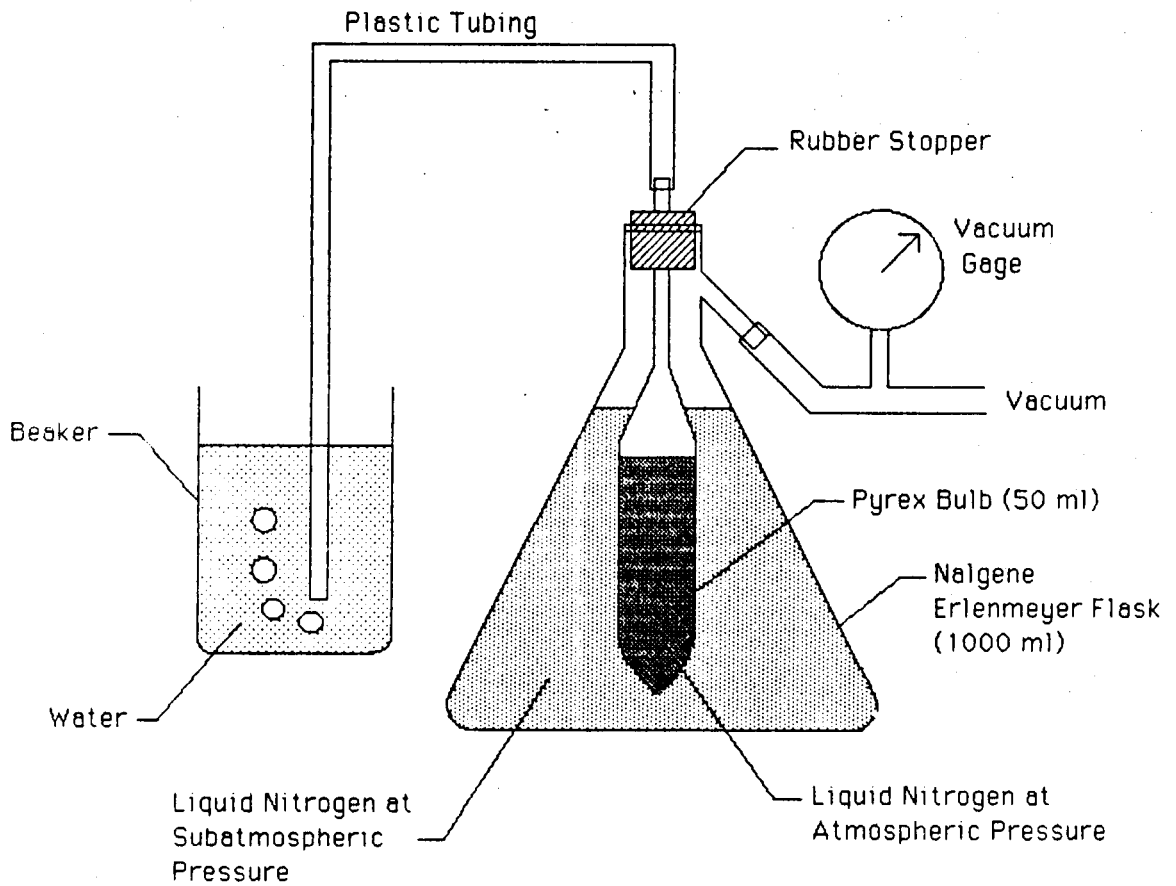

Figure 3. Demonstration Experiment for Cooling by Boiling Liquid Nitrogen at Subatmospheric Pressure

ORIGINAL PAGE IS
OF POOR QUALITY

A schematic diagram of this droplet generator is shown in Figure 4. The inner tube or droplet reservoir was constructed from a section of 3.8 cm diameter copper pipe about 33 cm long, while the outer jacket was made from 7.6 cm diameter copper pipe of approximately the same length. The capacities of the inner tube and the outer jacket are 350 ml and 1000 ml respectively. The entire outer jacket is insulated with a 2.5 cm thick layer of fiberglass wool covered with aluminum tape. The loudspeaker is connected to the upper end of the inner tube by a short length of PVC pipe. At the lower end of the inner tube a 2.5 cm length of 1.6 cm diameter copper pipe leads through the outer jacket to a threaded connection to which various capillary tubes can be attached.

The inner tube is provided with a venting and pressurization system through 0.63 cm diameter copper tubing. The venting is required during the cool down period when the liquid nitrogen in the inner tube is boiling. The vapors escape through the relief valve when the pressure exceeds about 2 psi. When the liquid nitrogen in the inner tube is subcooled and is not boiling, external pressurization from the laboratory gaseous nitrogen system is provided when necessary to obtain stable droplet formation. A water manometer is connected to this system to accurately measure this pressure, which ranges from zero to about 1.5 psi.

The outer jacket is provided with a vacuum system and a fill system. The vacuum line is connected to a vacuum gage and a valve for controlling the pressure in the cooling jacket. The vacuum is provided by two small vacuum pumps connected to a common manifold, giving a pumping capacity of about 400 liters/minute. The fill system consists of a reservoir connected by a valved 0.63 cm diameter insulated copper line. The insulated copper sphere from the earlier droplet generator was used for the jacket reservoir. The boiloff vapors from the spherical reservoir are used to provide a cold nitrogen purge for the insulation surrounding the droplet generator.

The following procedure was used for filling the droplet generator. With the jacket fill valve closed, the jacket reservoir is first filled using about 4 liters of liquid nitrogen from a small Dewar. The loudspeaker is then removed and the droplet reservoir is then filled. During the initial cooling down of the apparatus, considerable quantities of liquid nitrogen are boiled away, thus the droplet reservoir must be refilled several times. The valve is then opened to allow liquid nitrogen from the jacket reservoir to flow into the cooling jacket, and an additional 3 liters of liquid nitrogen is added to the jacket reservoir. The vacuum line is disconnected during this process, so that the jacket is at atmospheric pressure, and vapors from the liquid nitrogen boiling in the cooling jacket vent through the open vacuum line. When a spray of liquid nitrogen first emerges from the vacuum line, the cooling jacket is full and the flow from the jacket reservoir is shut off. Additional liquid nitrogen is then poured into the jacket reservoir and the droplet reservoir. A total of about 12 liters of liquid nitrogen is required to cool down and fill the droplet generator.

To operate the droplet generator, the vacuum line is then connected, and the vacuum pumps are started. After several minutes the jacket pressure stabilizes at about 0.67 atmosphere corresponding to a jacket temperature of

ORIGINAL PAGE IS
OF POOR QUALITY

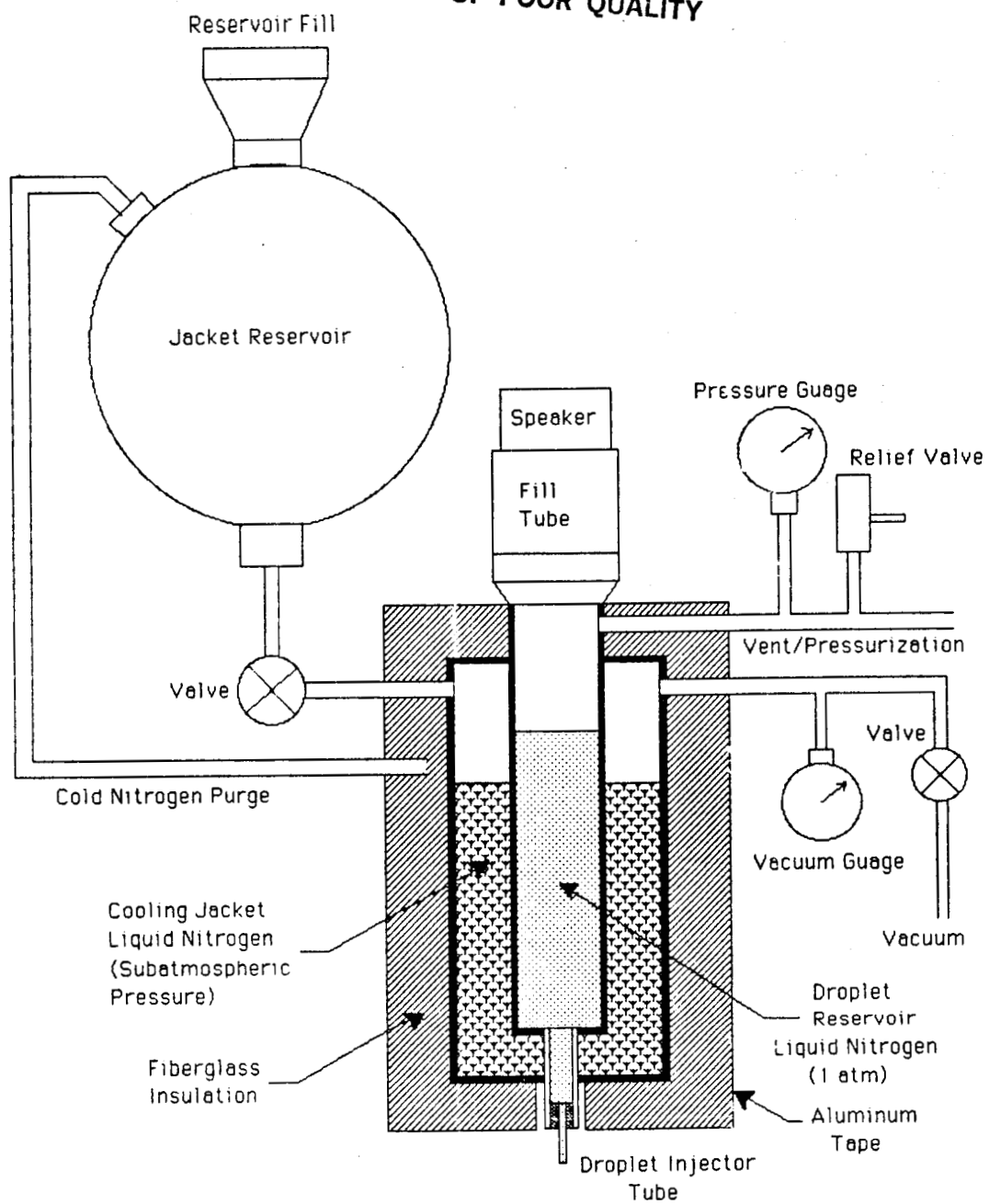

Figure 4. Monodisperse Liquid Droplet Generator, Second Design

about 74 K. At this point the droplet reservoir is again filled and the loudspeaker is replaced. As the liquid nitrogen in the inner reservoir is cooled the pressure in the droplet reservoir falls (measured with the manometer) as boiling ceases and some nitrogen recondenses. During steady state operation slight nitrogen pressurization of the inner reservoir is required to maintain the pressure about 0.1 psi above atmospheric pressure. This assures that a liquid nitrogen stream will always flow out of the capillary tube at the bottom of the droplet reservoir. During operation of the droplet generator, the valve from the jacket reservoir must be opened periodically to replace nitrogen boiling away in the cooling jacket.

The droplet generator was first tested using noncryogenic fluids such as water and ethanol. Acoustically driven periodic droplet formation was easily obtained over a frequency range of 300 Hz to 1300 Hz. Stroboscopically frozen images were obtained at driving frequencies which were integer multiples of the strobe frequency. Photographs of typical droplet streams are shown in Figure 5. The photograph on the left shows periodic droplet formation at about 600 Hz for water droplets. The droplets pinch off from the water stream at the top of the picture, where they are nearly spherical and uniform in size with a diameter of about 0.9 mm. As they fall they become noticeably ellipsoidal. The spacing between the drops is seen to be about 1.6 mm, which indicates a droplet velocity of about 1.0 m/sec. The photograph on the right shows water droplets produced without acoustic driving. These droplets are typical of chaotic droplet formation; they are produced in a range of sizes and at irregular intervals. The photographs in Figure 5 and others shown later in this report were obtained by playing a video recording of the droplet images into a digital image processing system. Using frame grabbing, individual video frames were displayed on the video monitor. These images were then photographed using Polaroid film in an oscilloscope camera.

Several test runs were made using liquid nitrogen in the droplet generator. In all of these tests the droplets were allowed to fall through room temperature air, and images were made of the drops a few centimeters below the capillary tube. During the most successful of these tests, monodisperse, acoustically driven periodic droplet formation was sustained for approximately one hour while various driving frequencies and droplet reservoir pressurizations were tried. With the droplet reservoir nearly full, the pressure head of the liquid nitrogen itself was usually sufficient for good droplet formation. At lower reservoir levels, pressurization with nitrogen or argon was needed; usually 0.5 to 1.5 psi was sufficient. The most uniformly sized droplets, which were also the most nearly spherical, were obtained with a driving frequency of 780 Hz (23 times the framing rate), but high quality droplets were also obtained at 720 Hz and 600 Hz. At this point in the test, the pressure in the cooling jacket was 0.77 atmosphere, corresponding to a boiling temperature of 75 K for the subatmospheric liquid nitrogen. This was apparently sufficient to eliminate boiling and two phase flow in the atmospheric pressure liquid nitrogen in the droplet reservoir, thus facilitating the production of monodisperse periodic droplets.

To further demonstrate that boiling of the liquid nitrogen in the droplet reservoir indeed prevents the formation of acoustically driven periodic

ORIGINAL PAGE IS
OF POOR QUALITY

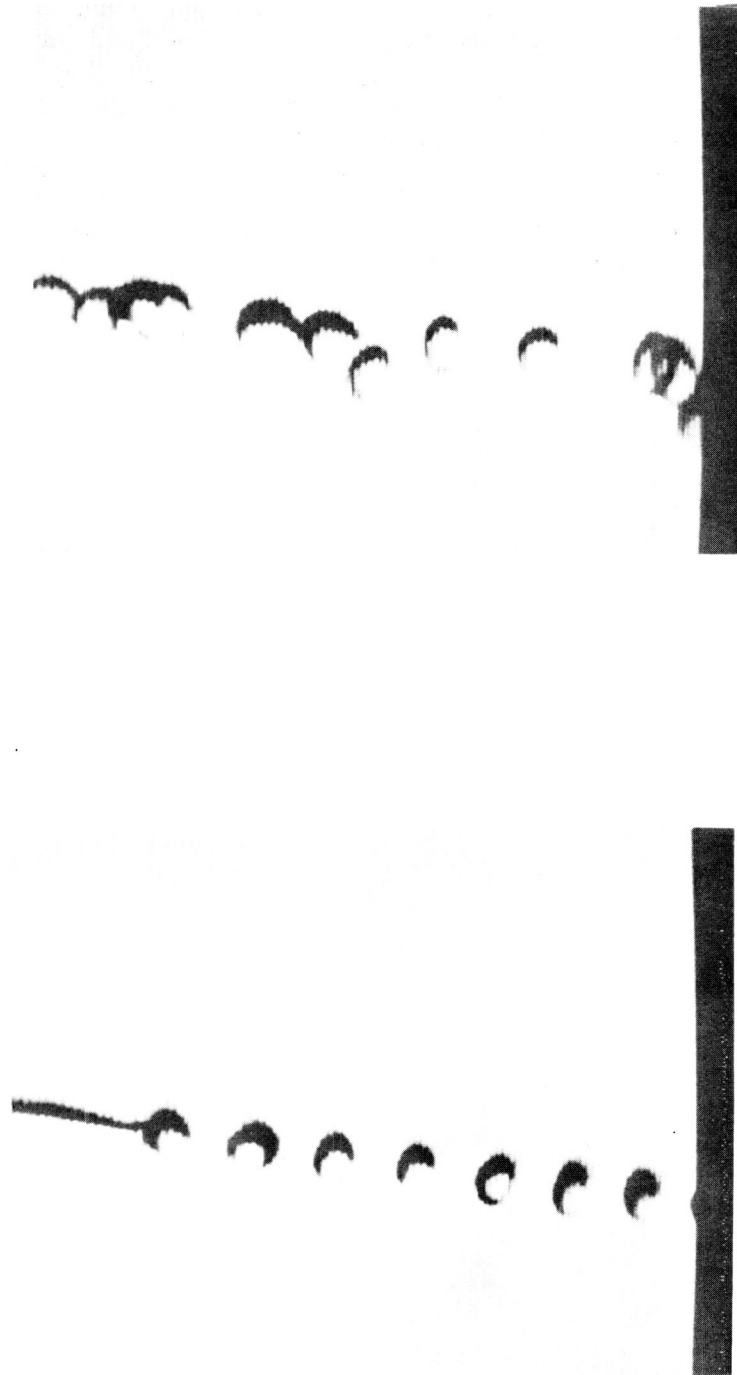

Figure 5. Water Droplets Produced by the Monodisperse Liquid Nitrogen Generator

droplets, the following procedure was carried out. The liquid nitrogen in the jacket was allowed to boil away with the jacket reservoir valve closed. Depletion of the liquid nitrogen in the jacket reservoir was indicated by a vacuum gage reading of about 0.05 atmosphere. At this point the droplet formation became chaotic; that is, it could not be synchronized with the strobe at any driving frequency. The jacket reservoir valve was then opened for about two minutes to allow liquid nitrogen to flow into the cooling jacket. Almost immediately acoustically driven periodic droplet formation was resumed. This was maintained for approximately four minutes while the liquid nitrogen in the jacket reservoir boiled away at about 0.5 atmosphere pressure (72 K). After the liquid nitrogen in the jacket reservoir was again exhausted, the droplet formation became increasingly random as the liquid nitrogen began to boil in the droplet reservoir.

MODIFICATION OF THE STEAM CHAMBER

A moderate pressure (80 psi) steam chamber used for a previous experiment in the Combustion Physics Laboratory at MSFC was modified for use as an atmospheric pressure steam chamber into which liquid nitrogen droplets could be injected. The modified steam chamber is shown in Figure 6.

The lower half of the existing chamber was retained essentially in its original form. This portion consists of two parts, a machined aluminum hexagonal observation section and a cylindrical lower chamber consisting of a flanged section of aluminum pipe. The observation section measures 35.6 cm across the flat faces and the central cylindrical cavity is 20.3 cm in diameter. The hexagonal block is fitted with six quartz windows 5.0 cm in diameter to provide optical access to the test chamber. The lower chamber also has an inside diameter of 20.3 cm and a length of 38.0 cm giving a total steam chamber height of 53.3 cm. The bottom of the lower steam chamber is closed with an aluminum plate with a 5 cm diameter central hole which allows steam to escape thus maintaining atmospheric pressure in the chamber. The lower chamber is wrapped with heating coils to maintain the steam chamber well above the atmospheric pressure boiling point of water (100 C) and thus prevent the condensation of liquid water in the chamber. The lower chamber and hexagonal block are insulated with about 2.5 cm thick layers of fiberglass wool wrapped in fiberglass tape. The hexagonal block contains no heating coils, but it is heated sufficiently by conduction from the lower chamber so that moisture does not condense on the optical windows. The steam is introduced into the lower chamber through a heated 1.3 cm diameter copper tube.

The upper portion of the steam chamber was modified for use with the monodisperse liquid nitrogen droplet generator. The top of the steam chamber is covered by a 28 cm diameter 3.2 cm thick aluminum plate, which is fitted with an O-ring seal and held down by six bolts. A 0.63 cm diameter hole at the center of the cover plate allows the liquid nitrogen droplets to enter the steam chamber. To prevent condensation of ice on the lower portion of the droplet generator and possible clogging of the capillary tube, a plenum chamber is used to separate the hot steam from the droplet generator. The plenum chamber consists of a flanged section of aluminum pipe which is bolted to the cover plate. The top of the plenum chamber is covered with a 0.3 cm thick circular aluminum plate with a 2.5 cm diameter central hole through which the insulated capillary tube is inserted. The plenum chamber provides a cylindrical cavity 10.2 cm in diameter and 7.3 cm deep which is purged with dry nitrogen to prevent steam from reaching the droplet capillary tube. The gaseous nitrogen enters the plenum chamber tangentially and disturbances to the droplet stream by the nitrogen flow are minimized by means of an internal baffle tube which extends to within about 1.0 cm of the top of the plenum chamber. The droplet generator fits tightly into the hole at the top of the plenum chamber so that all the nitrogen entering the plenum chamber exits through the hole at the bottom, thus preventing steam from entering the plenum chamber. The nitrogen flow rate is kept small, however, to prevent excessive dilution of the steam in the main chamber.

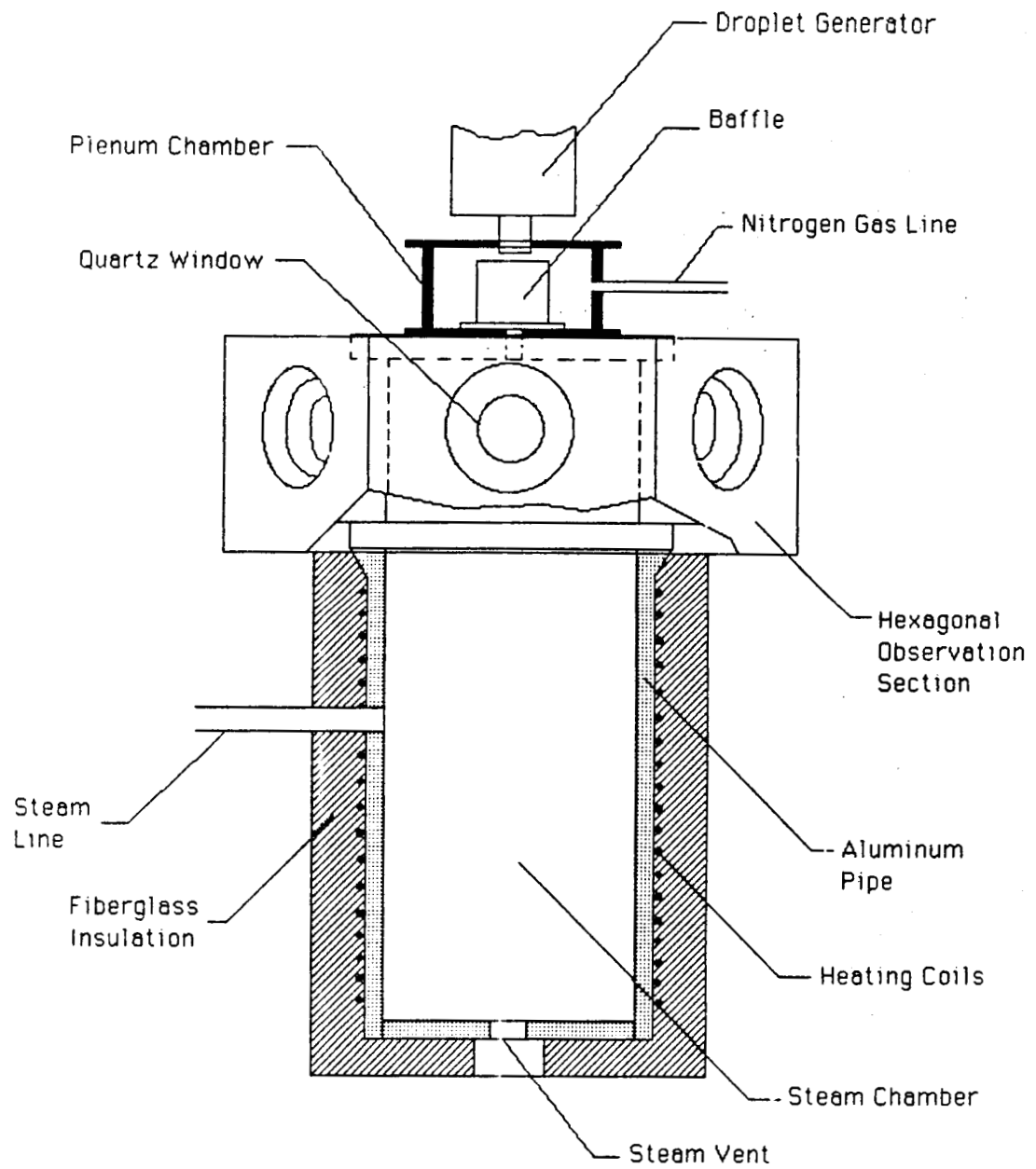

Figure 6. Atmospheric Pressure Steam Chamber

An existing boiler system was used to provide steam to the test chamber. This system is composed of a spherical stainless steel tank of approximately 38 liters internal volume wrapped with heating coils and heavily insulated. The boiler utilizes an internal pumping system to prevent thermal stratification in the boiler. The temperature of the boiler is controlled to an accuracy of 0.5 C using a platinum RTD thermocouple and controller. In the atmospheric pressure tests, the boiler temperature was held at about 98.4 C, and further heating of the steam occurred in the heated delivery line and the heated section of the steam chamber. During the steam tests, the test chamber surfaces were maintained at about 170 C using a separate thermocouple and controller.

RESULTS OF ATMOSPHERIC PRESSURE STEAM TESTS

Two tests were conducted in which liquid nitrogen droplets were injected into atmospheric pressure superheated steam using the monodisperse droplet generator and the modified steam chamber. The liquid nitrogen droplets were imaged using the stroboscopic video system used in previous tests of the droplet generator. In addition a stroboscopic laser shadowgraph system was used to view the droplets in this test.

The setup for the stroboscopic video system was slightly different than in previous tests due to the test cell geometrical constraints. The droplets could be viewed only at the fixed vertical location of the optical windows, which was about 18 cm below the droplet injector. Furthermore the camera could be placed no nearer than about 18 cm from the droplet stream, which was considerably farther than in previous tests in room temperature air. Consequently, the images of the droplets were considerably smaller than in the earlier tests.

The laser shadowgraph system was used to image density gradients in the vicinity of the droplets, which were invisible in the stroboscopic video images. This system utilized a 5 mW helium-neon laser (633 nm wavelength), which directed its beam to a rapidly rotating beam splitter cube. The cube was driven by a synchronous motor at 1800 rpm, giving a beam which scanned a small aperture at a frequency of 30 Hz, which is synchronous with the video framing rate. The duration of an individual pulse from the chopped beam was on the order of 5 μ sec, thus easily "freezing" the motion of the droplets. The pulsed beam then passed through beam expanding and collimating optics to produce a parallel beam of light passing through the observation section of the steam chamber. The pulsed beam then entered a second video camera to form an image of the shadows produced by droplets and density gradients in the test section.

In the atmospheric pressure steam tests it was difficult to obtain acoustically driven periodic droplet formation, and it was sustained only for a few minutes at a time at infrequent intervals. This difficulty may have been due in part to the increased heat transfer to the capillary tube in these tests, which may have resulted in two phase flow in the droplet injector. The top of the plenum chamber was hot to the touch, indicating that there was considerable heat transfer through the plenum chamber to the droplet generator in spite of the flow of cold nitrogen purge gas.

Typical stroboscopic video images of the liquid nitrogen droplets falling through atmospheric pressure steam are shown in Figure 7. In the photograph at the top, the droplets are being produced periodically by the acoustic driver; however, it appears that two parallel streams of droplets are being produced by the injector. This is an illusion produced by horizontal motions of the individual droplets under the influence of turbulence in the plenum chamber and the steam chamber. These flow disturbances made it virtually impossible to obtain clean stroboscopically frozen droplet chains as

ORIGINAL PAGE IS
OF POOR QUALITY

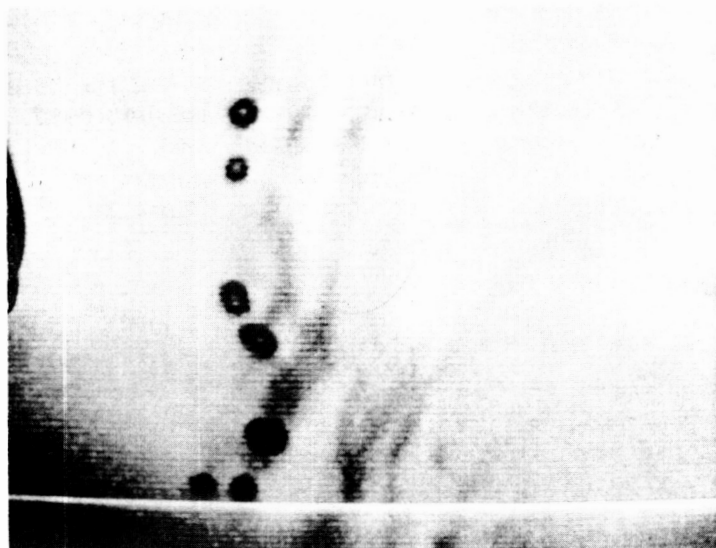
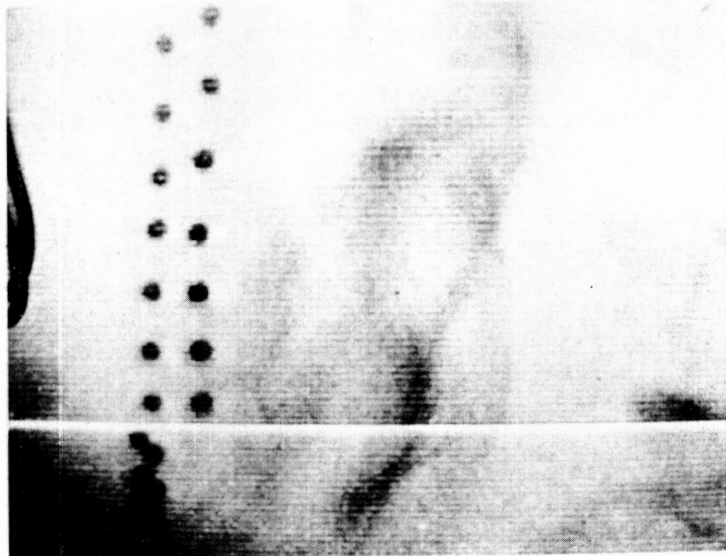

Figure 7. Stroboscopic Images of Liquid Nitrogen Droplets
Injected into Atmospheric Pressure Steam

were obtained in previous tests in atmospheric air (see Figure 5). The droplets in this photograph are approximately 600 microns in diameter. The lower photograph shows the droplets produced when the acoustic driver was unable to yield periodic monodisperse droplets. The droplets in the lower picture range in size from 600 to 1200 microns in diameter. The dark diffuse wisps to the right of the droplets in both photographs are due to the condensation of very small ice crystals and/or water droplets which occurs when the cold nitrogen vapors from the droplets mix with the hot steam in the chamber. These particles are produced predominantly in the wake of the falling droplets, forming comet-like tails several droplet diameters in length.

Images obtained with the laser shadowgraph system are shown in Figure 8. The upper photograph shows images of acoustically driven droplets produced synchronously with the laser pulse rate, while the lower photograph shows droplets obtained when periodic droplet production could not be maintained. Due to the small size of these droplets, the shadowgraph system does not produce sharp dark images of the droplets, but instead diffraction patterns are obtained. These patterns consist of concentric bright and dark rings which are dependent on the size and refractive index of the droplets. The oblique bands to the right of the droplets in the upper photograph are due to density gradients in the wakes of the three droplets shown and others below the field of view. These density variations are caused by temperature and composition gradients in the mixing regions in the wakes of the liquid nitrogen droplets. These density gradients are also visible in the wakes of the droplets shown in the lower photograph.

The images obtained of liquid nitrogen droplets injected into atmospheric pressure steam were unable to show any evidence of ice or water layers on the surfaces of the droplets. If any such layers of condensed phase water formed, they were probably only a few microns thick and were beyond the resolution of the imaging techniques employed. It is unlikely that the resolution of the direct imaging technique could be improved sufficiently to detect such thin ice/water layers. It is expected, however, that the diffraction patterns of the droplets may be affected by thin layers of ice and/or water sufficiently to be detected by the laser shadowgraph method if a higher power laser (5 W argon-ion) is employed and spatial filtering is used to clean up the background.

ORIGINAL PAGE IS
OF POOR QUALITY

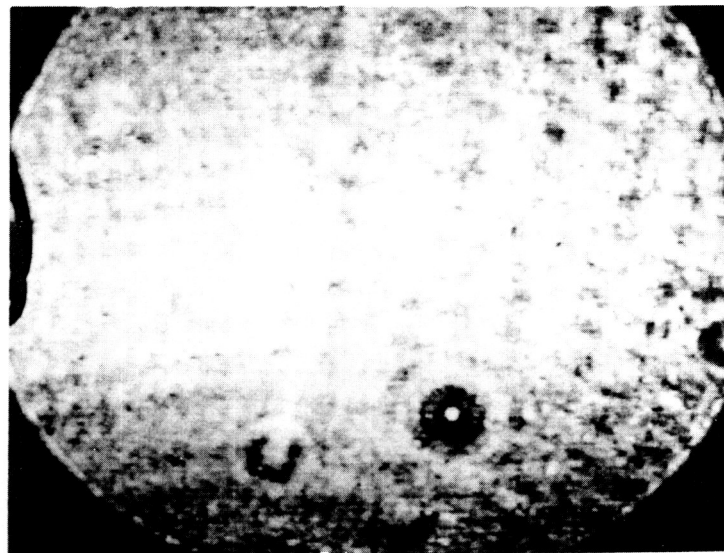
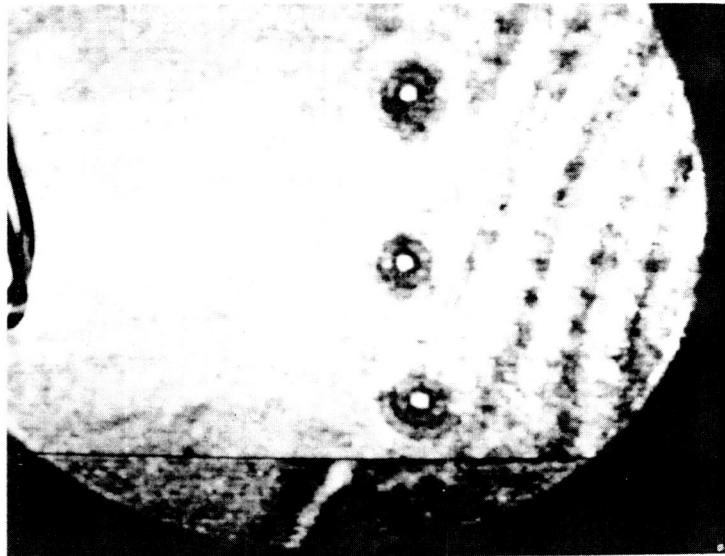

Figure 8. Laser Shadowgraph Images of Liquid Nitrogen Droplets Injected into Atmospheric Pressure Steam

CONCLUSIONS AND RECOMMENDATIONS

In summary, most of the objectives of this project have been successfully met. A monodisperse liquid nitrogen droplet generator was constructed which produces liquid nitrogen droplets of uniform size at regular periodic intervals. This generator operates on the principle of acoustic excitation of an atmospheric pressure reservoir of liquid nitrogen cooled below its boiling point by means of a bath of liquid nitrogen boiling at subatmospheric pressure. The existing steam chamber was modified for the investigation of the formation of ice and water layers on liquid nitrogen droplets. Several tests in which liquid nitrogen droplets were injected into atmospheric pressure superheated steam were conducted. In these tests two diagnostic methods were evaluated: stroboscopic direct imaging of the droplets and pulsed laser shadowgraph imaging. Although neither diagnostic technique showed the presence of ice or water layers on the droplet surfaces, it is believed that such layers may be detectable by an improved version of the shadowgraph technique.

A new laser system has been recently acquired in the Combustion Physics Laboratory at MSFC which could be employed in the detection of ice and water layers on the liquid nitrogen droplets injected into steam. This system consisting of a tunable dye laser pumped by a pulsed xenon-chloride excimer laser has the potential of providing sufficient power to yield Raman imaging of the ice/water layers if they are present. The use of the stroboscopic imaging technique developed in this project would be advantageous here, since the Raman scattered intensity is expected to be small.

Based on the work conducted on this project the following recommendations are made:

The laser shadowgraph technique should be improved using a 5 W argon-ion laser and spatial filtering. Theoretical calculations of the effect of a thin ice or water layer on the diffraction patterns produced by the droplets are necessary for use of this diagnostic technique.

The pulsed dye laser system at MSFC should be used to obtain images of the ice and water layers by means of Raman scattering of the laser radiation. This system would be used in connection with the stroboscopic imaging technique for periodically produced monodisperse liquid nitrogen droplets.

A high pressure steam chamber should be designed and constructed which will provide better simulation of the SSME environment. This will require modifications of the liquid nitrogen droplet generator to enable the droplets to be injected at high pressure.

Other diagnostic techniques should be explored. For example measurements of scattered laser light at various angles coupled with Mie scattering theory may enable thin layers of water or ice to be detected on liquid nitrogen droplets, since the index of refraction of these materials are different. Theoretical investigations based on Mie scattering calculations for layered dielectric spheres are needed to determine the feasibility of this method.

REFERENCES

1. Priem, R. J. and Heidmann, M. F., "Propellant Vaporization as a Design Criterion for Rocket Engine Combustion Chambers", NASA TR R-67, 1960.
2. Wieber, P. R., "Calculated Temperature History of Vaporizing Droplets to the Critical Point," AIAA Journal, Vol. 1, No. 12, 1963, pp. 2764-2770.
3. Manrique, J. A. and Borman, G. L., "Calculations of Steady Droplet Vaporization at High Ambient Pressures", Journal of Heat and Mass Transfer, Vol. 12, 1969, pp. 1081-1095.
4. Liang, P. Y., Fisher, S., Chang, Y. M., "Comprehensive Modeling of a Liquid Rocket Combustion Chamber," AIAA paper 85-0232, AIAA 23rd Aerospace Sciences Meeting, Reno, Nevada, January 1985.
5. Handbook of Chemistry and Physics, 69th Ed., 1988-1989, CRC Press, Inc., Boca Raton, Fla.
6. Scott, R. B., Cryogenic Engineering, D. Van Nostrand Company, Inc., Princeton, N.J., 1959.