

NASA Technical Memorandum 102016

Solar Dynamic Power for Space Station Freedom

Thomas L. Labus and Richard R. Secunde
Lewis Research Center
Cleveland, Ohio

and

Ronald G. Lovely
Rocketdyne International
Canoga Park, California

(NASA-TM-102016) SOLAR DYNAMIC POWER FOR
SPACE STATION FREEDOM (NASA. Lewis
Research Center) 24 p CSCL 22B

N89-23516

Unclas
G3/20 0204403

Prepared for the
International Conference on Space Power
sponsored by the International Astronautical Federation
Cleveland, Ohio, June 5-7, 1989

NASA

SOLAR DYNAMIC POWER FOR SPACE STATION FREEDOM

Thomas L. Labus and Richard R. Secunde
NASA Lewis Research Center
Cleveland, Ohio 44135

and

Ronald G. Lovely
Rocketdyne Division, Rocketdyne International
Canoga Park, California 91303

SUMMARY

The Space Station Freedom Program is presently planned to consist of two phases, the baseline phase and the growth, or evolutionary, phase. At the completion of the baseline phase, Freedom's manned base will consist of a transverse boom with attached manned modules and 75 kW of available electric power supplied by photovoltaic (PV) power sources. In the initial growth phase, electric power available to the manned base will be increased to 125 kW by the addition of two solar dynamic (SD) power modules, one at each end of the transverse boom. Power for manned base growth to 300 kW will be supplied by additional SD equipment. Studies have shown that SD power for the growth eras will result in life cycle cost savings of \$3 to \$4 billion when compared to PV-supplied power.

In the SD power module, a concentrator collects and focuses solar energy into a heat receiver which has integral thermal energy storage. A power conversion unit (PCU) based on the closed Brayton thermodynamic cycle removes thermal energy from the receiver and converts that energy to electrical energy. Waste heat from the thermodynamic cycle and module assemblies is rejected to space.

Since the closed Brayton cycle is a single phase gas cycle, the conversion hardware (heat exchangers, turbine, compressor, etc.) can be designed for operation in low earth orbit, and tested with confidence in test facilities on earth before launch into space. Temperatures of state points in the thermodynamic cycle are selected so that refractory materials are not necessary for long life.

All of the SD components are designed and packaged so that two complete SD power modules can be launched in a single Shuttle flight. The receiver/PCU/radiator combination is completely assembled and charged with gas and cooling liquid on earth before launch to orbit. Therefore, there will be no need to make on-orbit gas or liquid connections. The concentrator subassemblies will be pre-aligned and stowed in the Shuttle orbiter bay before launch. On orbit, the pre-aligned concentrator subassemblies will be latched together and the total concentrator attached to the receiver/PCU/radiator.

INTRODUCTION

Power for the manned base of Space Station Freedom will be supplied from two Solar Power Elements (SPE's). One SPE will be located on the port side of the transverse boom of the manned base and the other on the starboard side, each joined to the central part of the transverse boom by a single degree-of-freedom rotational gimbal (alpha gimbals). Initially, the SPE's on Freedom will supply a total of 75 kilowatts of electric power using photovoltaic (PV) power sources as shown in figure 1. As Freedom evolves and grows, increased power needs will be satisfied by the addition of Solar Dynamic (SD) power modules at the outboard ends of the initial SPE's as shown also in figure 1. Each set of SD hardware will add 25 kW of power to the manned base. For the first growth increment, which is expected to be 50 kW, one SD power module will be added on each side of the manned base. The evolution of Freedom is expected to require power capability growth to about 300 kW total.

There are two primary reasons for the interest in the solar dynamic system as the source of growth power. A PV/SD hybrid system offers the flexibility of a power system with two types of sources, thus assuring an uninterrupted supply of power in the unlikely event of a major or systematic failure in either type source. But even more compelling, is the potential cost savings that can be realized with SD. SD power generating and storage components have longer lifetimes than photovoltaic arrays and batteries. These SD lifetimes result in substantial cost savings in hardware replacement, launch, and on-orbit installation costs. Because of the significantly higher solar-to-electric power efficiency of a SD system, it has about a 60% smaller solar collection area than a PV system for a given power output. Therefore, it will have lower aerodynamic drag and lower reboost

requirements. For constant drag operation, SD systems allow the Freedom to operate at lower altitudes. This permits the Shuttle orbiter to rendezvous with the Freedom manned base at lower altitudes, significantly increasing the orbiter's payload capacity and lowering the launch cost per pound to orbit. Studies have shown that the various operations and hardware cost savings resulting from the use of SD power rather than PV power for the growth of Freedom's manned base, amount to a reduction in life cycle costs of 3 to 4 billion dollars over the 30 year life of Freedom.

In the present baseline phase of the Space Station Freedom Program, preliminary design of the SD power module will be completed along with developmental testing of critical components and subsystem testing. Also, the design and operational features which must be incorporated into Freedom's software (hooks) and hardware (scars) to allow the later addition of SD power modules will be defined. Inclusion of these hooks and scars into the baseline Freedom will allow power growth in an efficient and cost-effective manner.

It is the purpose of this paper to describe the performance requirements and the present overall design of the SD power module. Principles of operation, a top level description of the module and its components, and on-orbit module assembly are included. The design of this module will evolve and be optimized as the program progresses. Therefore, the information in this paper must be considered preliminary.

THE SD POWER MODULE

Performance Requirements

Each SD power module must provide the users on the manned base 25 kW of electric power throughout the orbit under all insolation conditions. To meet this requirement, the module must collect solar energy, store part of the collected energy as thermal energy for use during the eclipse portion of the orbit, convert collected or stored energy to low frequency ac electric power with a thermodynamic heat engine, convert the low frequency power to power at the frequency of the primary power distribution system, and deliver that power to the interface between the SD module and the rest of the manned base. The power delivered at the interface must be greater than 25 kW to accommodate the losses in the distribution system and conversion to secondary dc power, and to supply the power needed for control and monitoring. The delivered 25 kW is measured as a total at the user connection points. The module must also be capable of supplying a short term peak power of 28.75 kW to the user for up to 15 minutes of

an orbit. It must be capable of automated startup and shutdown operations and accommodate all of the electric power system functions on Freedom's manned base. These include initiating service, maintenance operations, corrective actions following failures or accidents, contingency operations, and safe haven operations.

Throughout the life of Freedom, the solar insolation will vary over a range of 1.33 kW per square meter to 1.42 kW per square meter. The SD module must be capable of accepting this varying insolation and delivering the required power at all times. In addition to the operating performance requirements outlined above, the SD hardware must be designed so that two complete modules can be delivered to orbit in one Shuttle launch. Finally, the SD modules must provide power during the total expected 30-year life of Space Station Freedom.

SD Principles of Operation

The operation of the solar dynamic electric power system for Freedom is shown in simplified form in figure 2. A reflecting concentrator focusses incident solar energy into a cavity-type heat receiver. The receiver includes heat exchanging tubes through which the gaseous working fluid for the closed loop Brayton cycle (CBC) heat engine passes. Also in the receiver is a quantity of a eutectic mixture of LiF-CaF_2 salts in capsules around the tubes for storage of thermal energy by the heat of fusion of that mixture. The phase change (freeze-melt) temperature of the salt mixture is near 1040°K (1420°F). During the sunlit portion of Freedom's orbit, sufficient thermal energy is stored so that the temperature of the gaseous working fluid at the receiver outlet remains within a range of about 990°K (1330°F) to 1030°K (1400°F) throughout the orbit.

The Brayton thermodynamic cycle is a single phase gas cycle. The SD power module uses the closed loop form of this cycle. A compressor raises the pressure of the gas working fluid after which it flows to a recuperator in which its temperature increases by transfer of heat from another part of the cycle. From the recuperator the gas passes to the receiver where collected heat is added and gas temperature rises to the maximum level in the cycle. The high temperature, high pressure gas then flows to the turbine where it expands to a lower temperature and pressure to produce mechanical work. A portion of the turbine work drives the compressor and the remainder drives the alternator, producing electrical energy. After leaving the turbine, the gas passes through the low pressure side of the recuperator where it transfers large part of its remaining heat energy to the high pressure gas from the compressor. From the

recuperator, the gas passes through the heat rejection system where it gives up more heat which is radiated to space. The cold gas then returns to the compressor, completing the loop.

The temperatures of the state points in the CBC have been selected so that refractory materials are not needed anywhere in the system. The gaseous working fluid is a mixture of helium and xenon with an equivalent molecular weight of 40, which results in the best combination of heat transfer and thermodynamic performance. Since the Brayton cycle is all gas, it is essentially insensitive to gravitational forces. Therefore, components and the system can be designed for space operation and the performance proven with confidence in test facilities on earth.

A solid rotor, Lundell type, three phase alternator mounted on a common shaft with the turbine and compressor converts mechanical energy to electric energy as three phase power. Electronic frequency changer equipment converts the three phase electric power from the alternator to distribution quality power.

The SD system must convert all of the energy collected by the concentrator since it is impractical to modulate, or control, energy collection. Therefore, variations in solar input energy (insolation) and in electric load demand are accommodated by a combination of control of the total amount of gas in the closed loop and a controllable parasitic electric load. The gas inventory in the loop is increased or decreased by valves connecting the accumulator to the compressor inlet or outlet, respectively.

Description of SD Power Module and Its Components

Figure 3 is a photograph of a model of the SD power module and in figure 4 the main components and assemblies of the module are indicated. The module includes six bays of the common 5-meter truss structure used on Freedom. The SD functional equipment is attached to the outermost bay by a single degree of freedom gimbal (beta gimbal). The inner 5 bays assure adequate clearance for rotation of the equipment and to prevent shadowing of the concentrator by other power modules. The axis of rotation of this beta gimbal is at 90 degrees to the axis of the alpha gimbal. The combined operation of the alpha and beta gimbals provide the coarse pointing of the concentrator. The alpha gimbal rotates once per orbit to provide orbit-by-orbit sun tracking. The beta gimbal oscillates very slowly through an arc of about + and - 52 degrees to track the sun through its periodic variation in position relative to the plane of Freedom's orbit.

The major assemblies in the SD power module are: 1) the concentrator with its support structure and two-axis fine pointing gimbal, 2) the receiver, 3) the power conversion unit (PCU), 4) the heat rejection assembly, 5) the electrical equipment assembly (EEA), and 6) the beta gimbal. These assemblies are all mounted to, and tied together by, the interface structure, the seventh major assembly. Electronics for control, power conditioning, and data handling are in the electrical equipment assembly. All of the SD components are designed and packaged so that two complete SD power modules can be launched in a single Shuttle flight. The receiver/PCU/radiator combination is completely assembled and charged with gas and cooling fluid on earth before launch to orbit. Therefore, there will be no need to make on-orbit gas or fluid connections. The concentrator panels and facets will be pre-aligned and the panels, with facets installed, stowed in the Shuttle orbiter bay before launch. The SD module is expected to have a mass of about 7440 kg (16360 lb) complete with seven assemblies and six bays of truss.

For growth in power capability, additional sets of functional SD hardware will be added to Freedom's manned base. Each set will increase Freedom's power capability by 25 kW. These hardware sets may, or may not include truss bays, depending on the power increment added. SD equipment sets are designed to be located on opposite faces of the outermost truss bay to provide 50 kW on each six-bay truss set. Each set of SD functional hardware will be complete with beta gimbal, interface structure, and all hardware outboard of the beta gimbal.

Continuation of SD module operation and provision of power for the required thirty years will be by periodic maintenance and replacement of assemblies or parts as orbital replacement units.

Concentrator - The concentrator is the visually dominant assembly of the SD power module. It is an erectable structure designed to be assembled by astronauts on orbit. As shown in figure 4, it is an offset parabolic reflector system consisting of a reflective surface, support structure and a gimballed fine pointing mechanism. The reflective surface, shown in figures 5 and 6, is an assembly of 19 hexagonal panels each containing 24 triangular reflective facets. To assure effective distribution of incident solar flux within the receiver, the facets are contoured and fixed in position. The primary advantages of the offset parabolic, hexagonal panel, and facet design concepts are the resulting low mass moment of inertia of the SD module about Freedom's transverse boom, commonality of parts, and the

capability for compact stowage of the concentrator. The compact stowage helps enable the packaging of two complete SD modules in the Shuttle orbiter's payload bay.

Assembled engineering model concentrator panel frames are shown in figure 7. This hardware was developed as part of the advanced development phase of the Space Station Freedom program. Self-locking ball-and-socket latches located at the panel corners connect the panels together with to form the complete reflector. The reflector thus assembled is about 18 m (55 ft.) in diameter. The facets will be installed in the panels and aligned on earth before launch into orbit. A nine-strut structure supports the assembled panels. Three of the struts form a delta frame and provide stiffness to the panel assembly. The remaining six attach it to the two-axis gimbal rings. These gimbal rings together with linear actuators and a closed-loop control constitute a fine pointing system which will keep the concentrator pointed to within + or - 0.1 degree of the true sunline. The total mass of the concentrator complete with all structure and controls is expected to be about 1500 kg (3300 lb.). A more complete description of the concentrator can be found in reference 1.

Receiver - The receiver, located near the focal point of the concentrator, is the second link in the SD power process. As shown in figure 8, which is a photo of a model, and figure 9, the SD heat receiver is cylindrical in shape. It consists of a cavity lined axially with tubes through which the gaseous working fluid of the Brayton cycle flows. Each individual tube is surrounded by thermal energy storage means. Solar energy enters the receiver through an aperture in one end. This aperture is sized to optimize the collection of focussed energy from the concentrator while limiting the amount of that energy which is reradiated out of the aperture. The gaseous working fluid enters the cavity region via a toroidal header at the aperture end of the receiver. It makes a single pass through the tubes and is then collected in an outlet header at the closed end. From the outlet header it flows to the Brayton power conversion unit which is mounted on the outside of the closed end.

The canisters surrounding each receiver tube contain a eutectic salt mixture of 80.5 % LiF - 19.5 % CaF₂ (by mole). The heat of fusion of this mixture is the thermal energy storage means. The total amount of salt in the receiver is sufficient to store the thermal energy of a maximum insolation orbit and to provide the required energy during the dark portion of a maximum eclipse orbit.

The receiver cavity walls consist of rigid, high temperature, formed insulation which reflects as well as reradiates incident solar thermal energy to outer side of the canisters surrounding the tubes. Multifoil insulation is wrapped around the outside of the rigid insulation and the entire receiver is enclosed in an aluminum support structure. The inlet header and aperture frame are protected from incoming solar flux by a graphite shield. This shield is designed to withstand spillage of solar energy due to concentration accuracy limitations and during the times when the SD module is offpointed from the sun. Offpointing occurs during startup and shutdown operations and transiently during pointing control functioning after a disturbance. A more complete description of the receiver can be found in reference 2. The receiver is expected to have a mass of about 1760 kg (3870 lb).

Power Conversion Unit - The power conversion unit (PCU) is the heat - to - electric power conversion heart of the SD module. It contains the turbomachinery, alternator, combined recuperator/cycle gas cooler, ducting, and gas storage and management equipment. These components are shown in figure 10. The turbomachinery (turbine and compressor) and the alternator are on a common shaft forming a single rotating unit referred to as the Brayton Rotating Unit (BRU). Both the turbine and compressor are single stage radial machines and operate at a design speed of 32,000 rpm. The alternator is a solid rotor, modified Lundell type machine which converts shaft power to three phase ac electric power at 120 volts line-to-neutral with a nominal frequency of 1067 Hz. All of the electrical windings of the alternator are on the non-rotating part of the BRU, thereby providing for effective cooling paths and minimizing mechanical stresses on the windings and their insulation. Cooling of the rotor and bearings is achieved by a small bleed gas cooler which cools gas bled from the compressor outlet and feeds the cooled gas into the rotor cavity. The alternator is cooled by a combination of the cooled gas and liquid coolant from the heat rejection system. Ducting and structural ties connect the BRU with the balance of the PCU and receiver.

The recuperator and cycle gas cooler form an integrated heat exchanger. There are double containment features at joints in pressure boundaries throughout both recuperator and gas cooler. The accumulator, which is the major part of the gas management system, is located along side of the BRU. The functions of the two heat exchangers and the accumulator are described in the section on principles of operation.

Control equipment located in the electrical equipment assembly (EEA) controls the BRU speed, alternator output voltage, power level, and start-stop functions. Electric power produced by the

BRU which is not delivered to the power distribution system because of low demand is passed to the parasitic load radiator (PLR), a resistive load which radiates the excess load as heat to space. The PLR also absorbs and radiates transient power excess during system load changes to maintain the proper BRU speed. Lastly, the PLR, together with the controls, regulates the steady state speed of the BRU. The PCU is described in greater detail in reference 3. The total mass of the various components and assemblies which make up the PCU is expected to be about 800 kg (1760 lb).

Heat Rejection Assembly - The heat rejection assembly consists of a pumped liquid loop which collects the waste heat from the thermodynamic cycle and electrical components and transfers it to a deployable radiator, and the radiator itself. Figure 11 shows the dominant part of this assembly, the radiator which is designed to reject about 100 kW of thermal power to space. The radiator is a deployable structure consisting eight 8.7 m (26.4 ft.) by 2.5 m (7.5 ft.) panels connected together by flexible fluid-carrying hoses. The panels are constructed of aluminum honeycomb adhesively bonded to aluminum face sheets. The face sheets are coated on the outside with a thermal control coating, presently planned to be Z-93 white paint. Within the honeycomb, extruded aluminum tubes conduct coolant fluid from the inlet manifold on one side of the panels to the outlet on the opposite side. The maximum expected coolant temperature at the inlet is 445 °K (340 °F). Several types of fluid are under consideration as the heat transport means. Dual coolant paths provide reliability and full operational capability after one failure.

The deployment mechanism is a cable-actuated scissors which extends the panels from a stowed layered position to the extended position as shown in figures 3, 4, and 11. The scissors mechanism also provides the structural support to maintain the radiator panels in position.

The radiator together with its deployment mechanism is expected to have a mass of about 1350 kg (3000 lb.). The total heat rejection assembly, complete with pumps, lines, and cold plate (for electronics thermal control) is expected to have a mass of about 1550 kg (3400 lb). More detailed information on the heat rejection system can be found in reference 4.

Electrical Equipment Assembly - The Electrical Equipment Assembly (EEA) contains a variety of electrical and electronic hardware and is mounted on a cold plate. For thermal control of this hardware, cooling fluid from the heat rejection assembly circulates through this cold plate. The EEA contains all of the controls for the SD power module. This includes pointing controllers which assure that the concentrator is pointed to

within 0.1 degree of the sunline. These controllers drive both the beta and fine pointing gimbal actuators and are interfaced with alpha gimbal controls in the central portion of the manned base. Control of the PCU includes control for voltage and speed, startup and shutdown sequencing, and mass flow rate of the gas (power level). Control of the mass flow rate assures maintenance of proper temperatures in the receiver. Pump motors for the heat rejection assembly and their drive electronics are also in the EEA. Finally the EEA includes the frequency changer which converts the nominal 1067 Hz, 3-phase power from the alternator to 20 kHz single phase power for primary distribution. The mass of the EEA is expected to be about 260 kg (570 lb).

Beta Gimbal - The beta gimbal is a single degree - of - freedom gimbal which, together with the alpha gimbal, provides the coarse pointing of the SD power module. Although it only rotates through an angle of + and - 52 degrees during normal operation, it can rotate a full 360 degrees to allow full detracking of the SD module from the sunline for assembly, maintenance, and emergency operations. It includes both electric power and data coupling between the assemblies of the SD power module and the truss. The mass of the complete beta gimbal is expected to be about 280 kg (610 lb).

Interface Structure - All of the functional SD assemblies described above are mounted on the interface assembly as shown in figure 4. It is oriented in inertial space by the alpha and beta gimbals, and is the base from which the fine pointing of the concentrator operates. The interface structure mass is expected to be about 375 kg (825 lb).

Technology Base

The Solar Dynamic power module is based on a solid technological heritage at both the system and component levels. For the Closed Brayton Cycle (CBC) Power Conversion Unit (PCU), the technology to build this engine exists. A 10.5 kW Brayton power conversion system was developed by AirResearch under the management of NASA-Lewis Research Center in the 1960's and 1970's. Several sets of hardware were produced and tested [3]. These included BRU's, heat exchangers, controls, accumulators, etc.. These BRU's have a physical size, turbine inlet temperature (1600 °F) and shaft speed (36,000 RPM) roughly comparable to the current design of the CBC Solar Dynamic power module for Space Station Freedom. The same type of working fluid, a mixture of He and Xe gases, was also used. Two of the BRU's were successfully operated for 41,000 and 11,000 hours each with no failures or physical degradation. In fact, 13,600 hours of continuous operation was achieved on one of the units without any failures, maintenance or signs of wear or excessive creep. On a component basis, the Freedom PCU uses turbine, compressor and alternator design

concepts the same as those developed previously. Aircraft Auxiliary Power Units (APU's) have endured over 200 million unit-hours with over 200 million start/stop cycles with turbine and compressor designs that are similar. Gas foil bearings in the Freedom CBC rotating machinery design are of the same design and size as those used in the DC-10 environmental control cooling turbines (over 100 million unit-hours of operation and 71,000 start/stop cycles before replacement). Because of the experience in Brayton development, extensive government and industry experience in related aircraft components, and conservative design, extreme confidence exists in the capability of producing a space qualified PCU.

The radiator is another major assembly for which the technology base exists for the SD power module. Single phase, pumped liquid radiators have been previously flown aboard Apollo and Skylab and are now in use on the Shuttle [4]. The SD radiator, which uses adhesively bonded honeycomb construction techniques, takes advantage of the current state-of-the-art fabrication methods which are demonstrated by the Space Shuttle Orbiter's large single phase pumped loop radiators mounted on the cargo bay doors. In addition, the SD radiator uses an integrated automatic deployment mechanism and support structure which has also been used in orbit. The Skylab Apollo Telescope Mount (ATM) solar arrays were successfully deployed using the same basic concept that SD will use (i.e., a scissors arm with cable actuator). The SD power module will incorporate all the successful radiator technologies demonstrated previously. Building on this technology provides a low risk and low cost approach to producing a flight qualified radiator.

For the other two assemblies, the receiver and concentrator, a strong base has been developed since 1984 with the infusion of over 20 million dollars of NASA Advanced Development, Contractor Internal Research and Development, and NASA Supporting Development Resources. For the receiver assembly, a strong technology base involving thermal storage materials compatibility, mechanical strength, thermal energy storage performance, and receiver thermal performance has been developed. Over 5000 hours of exposure of the thermal storage containment materials to the LiF-CaF_2 salt show negligible corrosion. In addition, extensive testing at Lewis and at contractors has shown that the thermal performance is completely verifiable by ground testing and analysis (i.e., no flight test is required). Also, tests conducted by Allied-Signal with a single tube segment of the receiver has verified the operation of the baseline thermal energy storage configuration. Finally, a full-scale advanced development CBC receiver for a 25 kW SD system is being built at the Boeing Aerospace Corporation and will be tested during the summer of 1989. Rocketdyne, meanwhile, has completed an

impressive system demonstration test at their Santa Susanna test site in which a receiver unit with integral thermal energy storage, was mounted on a Vanguard concentrator and successfully demonstrated essentially uniform receiver/thermal storage capability.

Key accomplishments have been realized in concentrator reflective and protective coatings, optical characterization, and structural rigidity. The Harris corporation, Lewis Research Center, and 3M have demonstrated the reflective capability of the individual facets and the resistance of protective coatings to atomic oxygen. In addition, a full scale concentrator (19 panels) has recently been fabricated by the Harris Corp. A successful seven-panel assembly and repeatability test was completed recently. The concentrator is now at Lewis Research Center for a series of optical tests.

In conclusion, a strong technology base exists for the development of the Solar Dynamic power module system.

ON-ORBIT ASSEMBLY

On-orbit assembly of the SD modules will be accomplished using assembly equipment developed for the baseline phase of the Space Station Freedom Program (SSFP). In addition, assembly of the SD modules will employ many of the techniques developed and performed on-orbit during the baseline phase, such as those required for Photovoltaic (PV) module assembly. The assembly concepts for either phase, however, will require extensive testing and evaluation as SSFP hardware matures. The text below provides a brief overview of the SD module assembly concept.

Assembly of the SD modules will rely on the Mobile Servicing Center (MSC) for transporting equipment to the assembly area outboard the alpha gimbal and positioning components for installation. The MSC will also serve as a work platform for the Extravehicular Activity (EVA) required for SD module assembly. Details about the MSC are provided in reference [5]. The Astronaut Positioning System (APS) attached to the Mobile Transporter (MT) on the MSC will position the EVA crew to make structural and utility connections after SD module components have been positioned by the Space Station Remote Manipulator System (SSRMS). Figure 12 depicts the necessary assembly equipment and the SD module components as they would be located on the MSC.

Transferring SD module components from the Orbiter payload bay to the MSC, and transporting those components to the assembly site, will be controlled by the man-based Intravehicular Activity (IVA) crew using the Shuttle Remote Manipulator System (SRMS), the SSRMS, and a telerobotic system such as the Special Purpose Dexterous Manipulator (SPDM) or Flight Telerobotic Servicer (FTS) operating from the end of the SSRMS.

The EVA crew (2 crewmen) will translate to the MSC using the Crew and Equipment Translation Aid (CETA) and ingress the foot restraints on the APS. The EVA crew will erect 6 truss bays and install utility trays as depicted in Figure 12. The truss assembly method is based on the Langley Research Center (LaRC) Mobile Transporter concept which has been tested under neutral buoyancy conditions [6].

The SSRMS will be used to retrieve from the MSC, and position for installation, each main component. The beta gimbal is installed first (figure 13a), followed by the Receiver/Radiator Assembly, and then the gimbal ring (figure 13b). The structural and utility connections for each component will be performed by the EVA crew on the APS. The basic partitioning of functions between EVA crew and teleoperated systems is similar to that described elsewhere for assembly of a submillimeter astronomical laboratory [7]. To assemble the concentrator support structure, one crewman will be positioned by the SSRMS using a Manipulator Foot Restraint (MFR) while the other will remain on the APS (figure 13c). The radiator will be deployed manually by the EVA crew using an EVA torque tool.

For concentrator assembly, the EVA crew will be positioned on the APS as shown in figure 14a. A grapple fixture will be mounted on the back side (non-reflective surface) of the central hexagonal panel and grappled by the SSRMS. Each additional panel will be raised from the concentrator container by the EVA crew and latched to the panel above. The wrist joint of the SSRMS will rotate following the latching of each panel to provide clearance and prepare for the latching of the next panel. Once assembly of the concentrator is complete it will be placed on the concentrator support structure by the SSRMS (figure 14b). The operations will be planned to avoid positioning the concentrator on-sun until the initiation of start up procedures.

CONCLUDING REMARKS

A design for a Solar Dynamic power module that meets all of the performance requirements for operating on orbit as a power source on Space Station Freedom has been presented. This module will provide 25 kW of electric power to the users under all insolation conditions. In addition, the design meets the requirements for short term power peaking (up to 28.75 kW) and is capable of automated startup and shutdown operations. The design allows the launch of two complete SD modules with one Shuttle flight. It also has been designed to provide power during the 30-year Freedom lifetime by periodic, as needed, replacement of orbital replacement units. Assembly of the module on orbit will incorporate methods and procedures to be developed for other Freedom elements --- no unique equipment will be needed. The technology base for SD development and production has been shown to exist at both the system and component levels.

We have described the process by which SD becomes a part of the Space Station Freedom. The initial growth phase will increase the power level to 125 kW by the addition of two SD power modules, one at each end of the transverse boom. Power for Freedom's growth to about 300 kW will occur by adding SD modules. During the current baseline program, there is funding to conduct SD preliminary design, define software (hooks) and hardware (scars) features which must be incorporated into the design of baseline Freedom, and conduct development testing of critical SD components and key subsystems.

We have clearly indicated the reasons for adding SD power to Freedom. The tremendous life cycle cost savings, in conjunction with the advantage of having a hybrid or alternate power source just in case some anomaly with PV occurs, are attractive reasons for pursuing development of SD power for Freedom.

In summary, the SD module design meets the requirements of the Space Station Freedom Program, the technology base exists and the existing program is preparing Freedom for growth with SD. Given the tremendous life cycle cost savings and the attractiveness of an alternate power source, the only question is when to grow beyond 75 kW.....

Acknowledgements:

The authors wish to acknowledge the assistance of Daniel Clark in the development of Solar Dynamic module on-orbit assembly procedures.

REFERENCES

1. Corrigan, R.D.; and Ehresman, D.T.: "Solar Concentrator Advanced Development Project." Energy - New Frontiers (22nd IECEC), Vol. 1, AIAA, 1987, pp 156-161.
2. Strumph, H.J.; and Coombs, M.G.: "Solar Receiver for the Space Station Brayton Engine." Paper number 87-GT-252, Proceedings of the Gas Turbine Conference and Exhibition, Anaheim, CA, May 31-June 4, 1987, ASME, 1987.
3. English, R.E.: "Power Generation from Nuclear Reactors in Aerospace Applications." Symposium on Advanced Compact Reactors, Sponsored by the National Research Council; Washington, D.C.; Nov. 15-17, 1982; NASA TM 83342.
4. McLallin, K.L.; Fleming, M.L.; Hoehn, F.W.; and Howerton, R.: "The Solar Dynamic Radiator With A Historical Perspective." Paper number 889165, Proceedings of the 23rd Intersociety Energy Conversion Engineering Conference, Vol. 3, ASME, 1988.
5. Space Station Freedom Baseline Configuration Document, SSP 30255, Rev. C, August 15, 1988.
6. Watson, J.J.; Heard, W.L.; Bush, H.G.; Lake, M.S.; Jensen, J.K.; Wallsom, R.E.; Phelps, J.E.: "Results of EVA/Mobile Transporter Space Station Truss Assembly Tests". Langley Research Center, NASA Technical Memorandum 100661, November 1988.
7. Bush, H.G.; Lake, M.S.; Watson, J.J.; Heard, W.L.: "The Versatility of a Truss Mounted Mobile Transporter for In-Space Construction". Langley Research Center, NASA Technical Memorandum 101514, November, 1988.

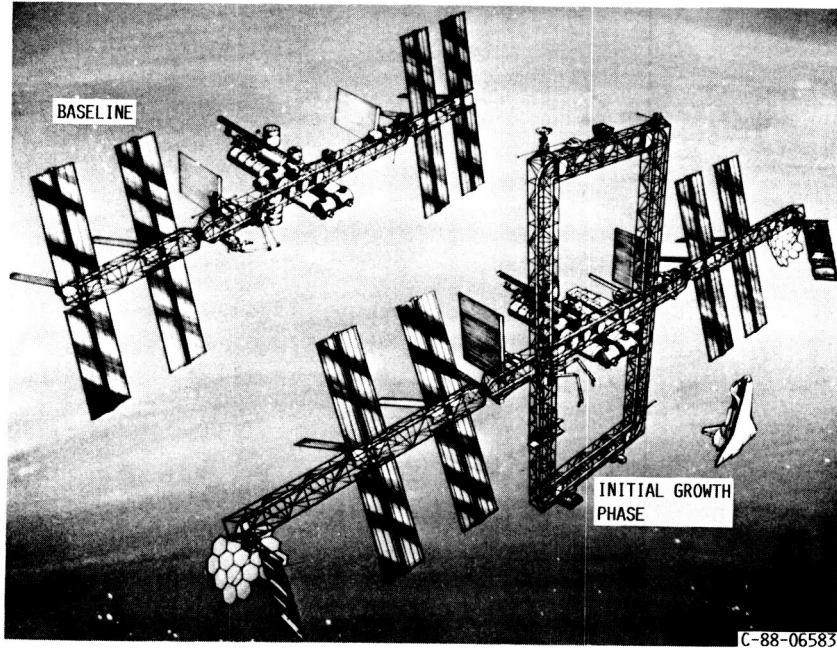

FIGURE 1. - SPACE STATION FREEDOM.

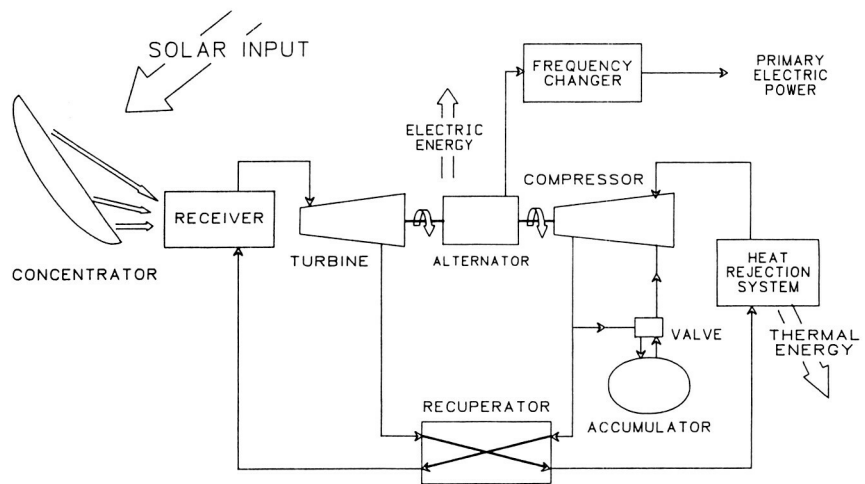

FIGURE 2. - SOLAR DYNAMIC CLOSED BRAYTON CYCLE.

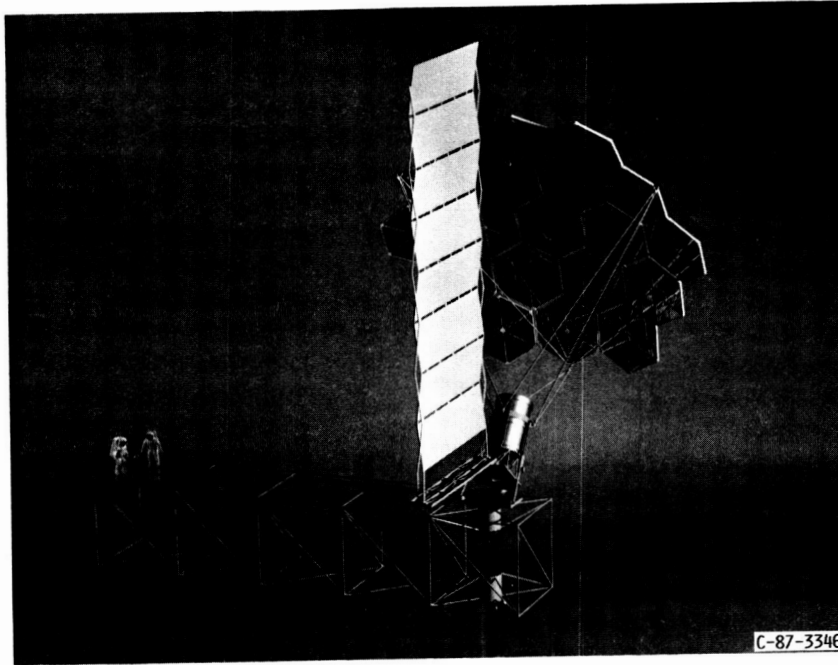

FIGURE 3. - MODEL OF SOLAR DYNAMIC POWER MODULE.

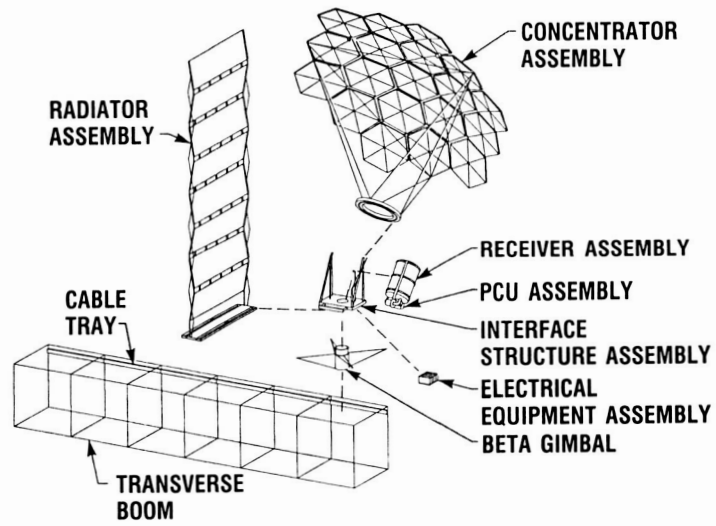
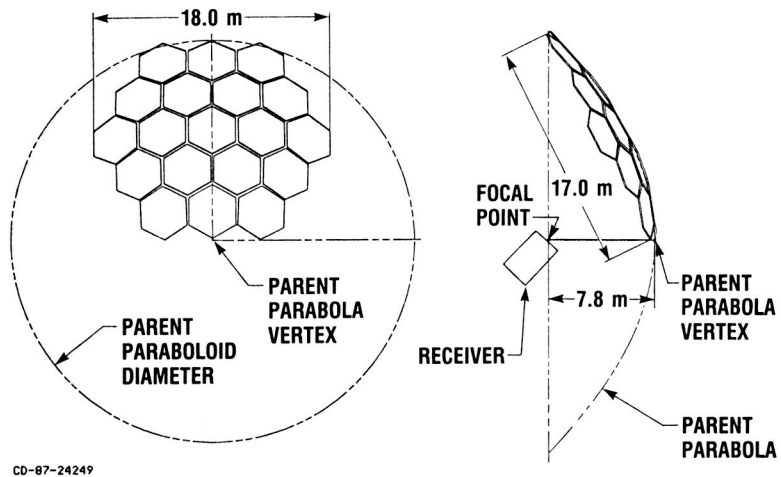

FIGURE 4. - SOLAR DYNAMIC POWER MODULE COMPONENTS.



CO-87-24249

FIGURE 5. - OFFSET CONCENTRATOR.

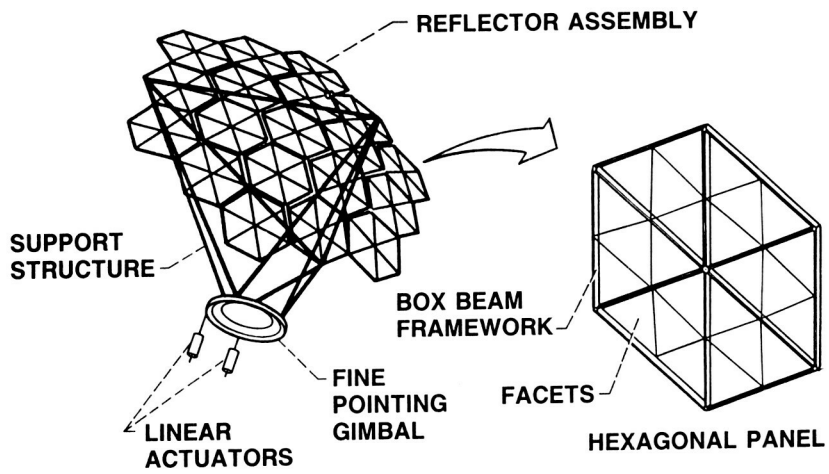

FIGURE 6. - CONCENTRATOR ASSEMBLY.

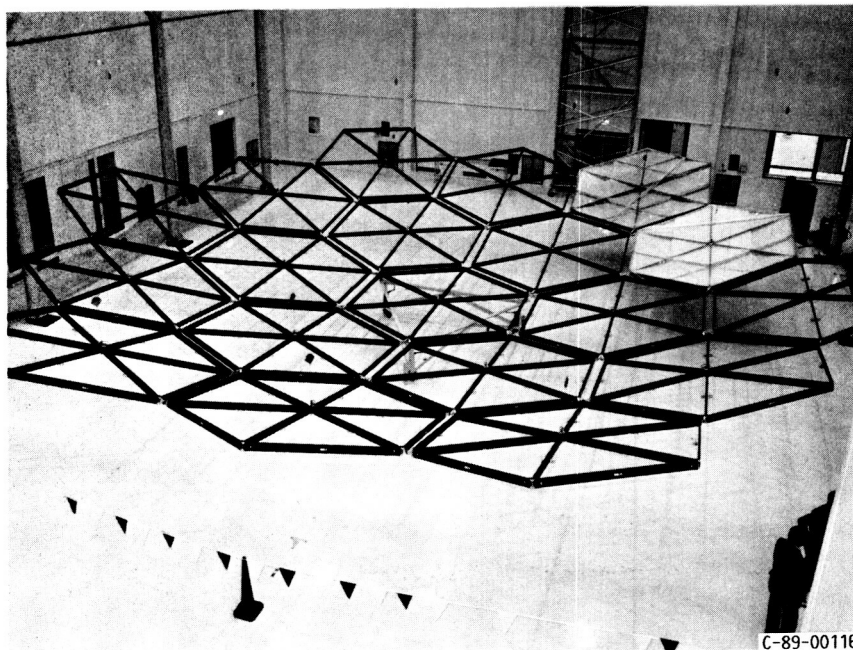

FIGURE 7. - CONCENTRATOR PANEL STRUCTURE.

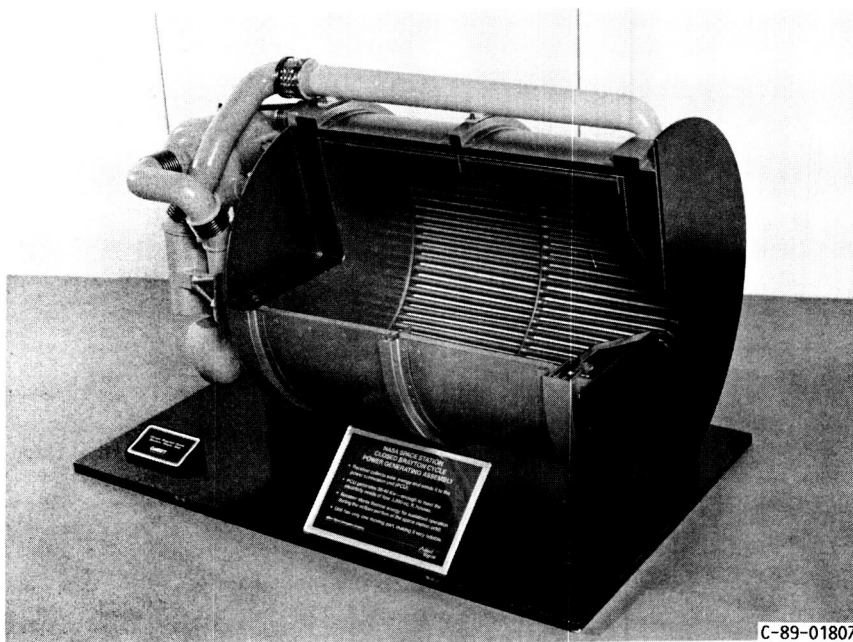

FIGURE 8. - RECEIVER WITH THERMAL ENERGY STORAGE.

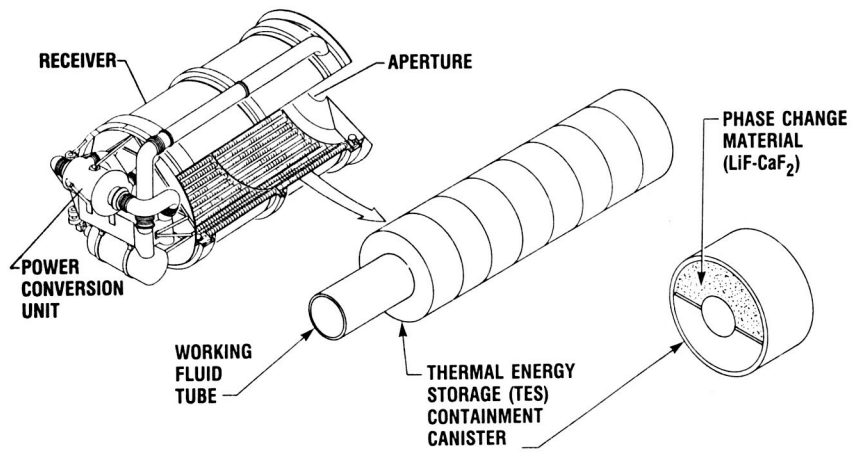

FIGURE 9. - THERMAL ENERGY STORAGE.

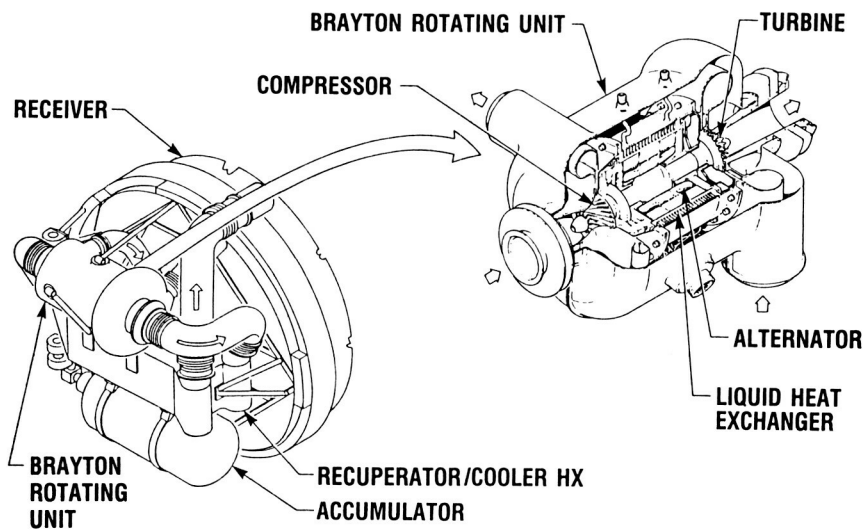

FIGURE 10. - POWER CONVERSION UNIT.

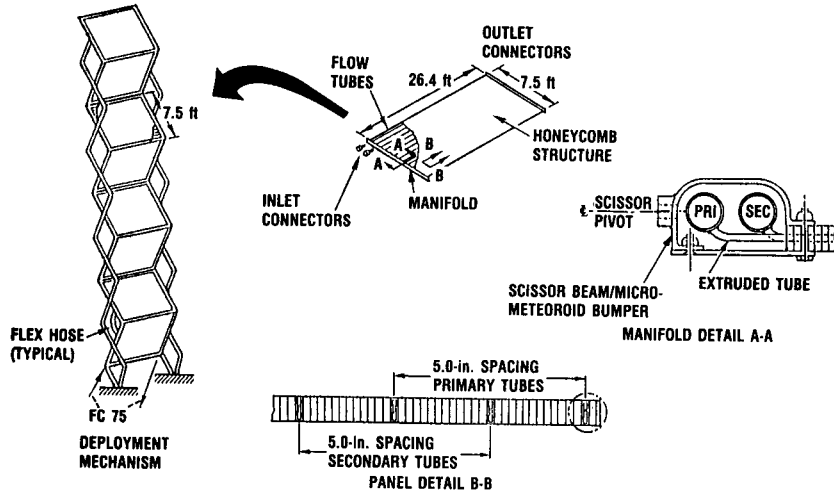

FIGURE 11. - DEPLOYABLE RADIATOR.

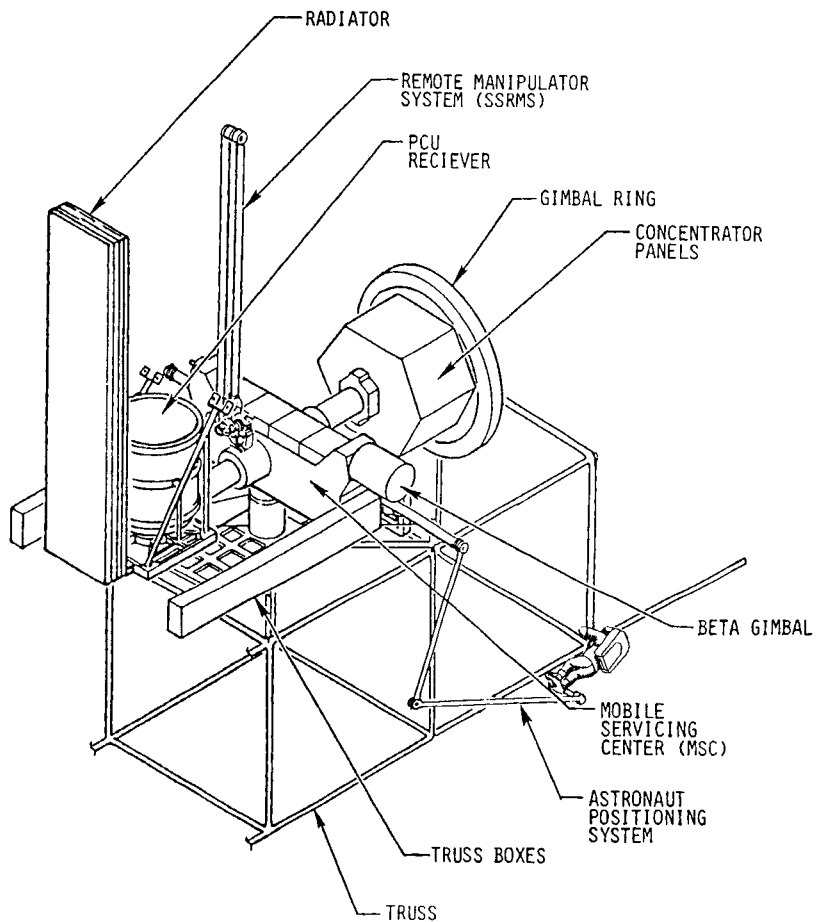

FIGURE 12. - MSC ACCOMMODATES STOWAGE OF SD MODULE COMPONENTS FOR TRANSPORT TO ASSEMBLY SITE.

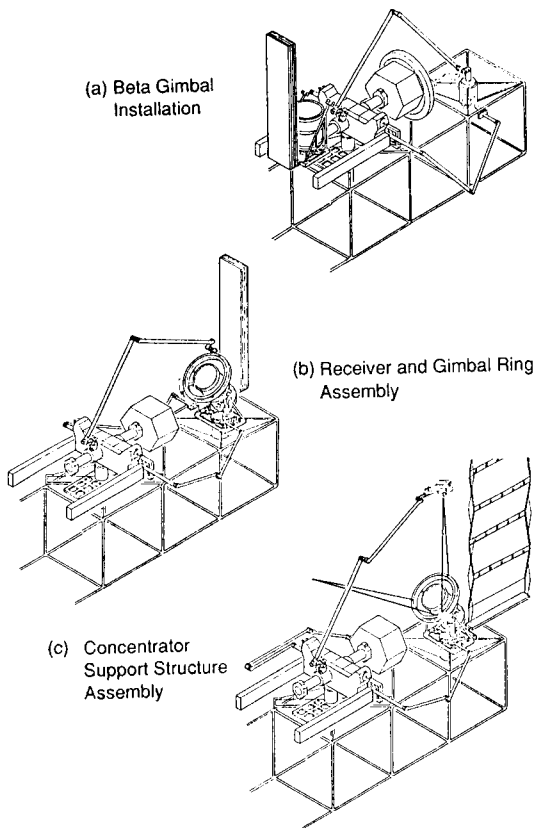

FIGURE 13. - ASSEMBLY OF BETA GIMBAL, RECEIVER, GIMBAL RING AND CONCENTRATOR SUPPORT STRUCTURE.

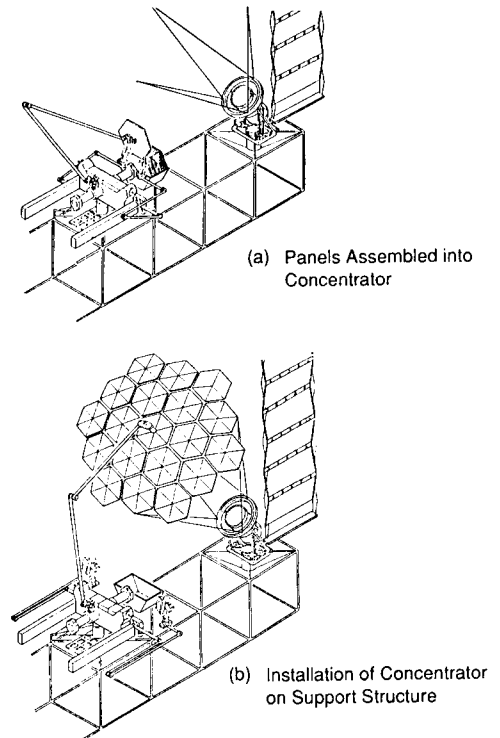

FIGURE 14. - CONCENTRATOR ASSEMBLY.



Report Documentation Page

1. Report No. NASA TM-102016		2. Government Accession No.		3. Recipient's Catalog No.	
4. Title and Subtitle Solar Dynamic Power for Space Station Freedom				5. Report Date	
				6. Performing Organization Code	
7. Author(s) Thomas L. Labus, Richard R. Secunde, and Ronald G. Lovely				8. Performing Organization Report No. E-4730	
				10. Work Unit No. 474-52-10	
9. Performing Organization Name and Address National Aeronautics and Space Administration Lewis Research Center Cleveland, Ohio 44135-3191				11. Contract or Grant No.	
				13. Type of Report and Period Covered Technical Memorandum	
12. Sponsoring Agency Name and Address National Aeronautics and Space Administration Washington, D.C. 20546-0001				14. Sponsoring Agency Code	
15. Supplementary Notes Prepared for the International Conference on Space Power sponsored by the International Astronautical Federation, Cleveland, Ohio, June 5-7, 1989. Thomas L. Labus, Richard R. Secunde, NASA Lewis Research Center; Ronald G. Lovely, Rocketdyne Division, Rocketdyne International, Canoga Park, California 91303.					
16. Abstract The Space Station Freedom Program is presently planned to consist of two phases. At the completion of Phase I, Freedom's manned base will consist of a transverse boom with attached manned modules and 75 kW of available electric power supplied by photovoltaic (PV) power sources. In Phase 2, electric power available to the manned base will be increased to 125 kW by the addition of two solar dynamic (SD) power modules, one at each end of the transverse boom. Power for manned base growth beyond Phase 2 will be supplied by additional SD modules. Studies have shown that SD power for the growth eras will result in life cycle cost savings of \$3 to \$4 billion when compared to PV-supplied power. In the SD power modules for Space Station Freedom, an offset parabolic concentrator collects and focuses solar energy into a heat receiver. To allow full power operation over the entire orbit, the receiver includes integral thermal energy storage by means of the heat of fusion of a salt mixture. Thermal energy is removed from the receiver and converted to electrical energy by a power conversion unit (PCU) which includes a closed brayton cycle (CBC) heat engine and an alternator. The receiver/PCU/radiator combination will be completely assembled and charged with gas and cooling fluid on Earth before launch to orbit. The concentrator subassemblies will be pre-aligned and stowed in the orbiter bay before launch. On orbit, the receiver/PCU/radiator assembly will be installed as a unit. The pre-aligned concentrator panels will then be latched together and the total concentrator attached to the receiver/PCU/radiator by the astronauts. After final electric connections are made and checkout is complete, the SD power module will be ready for operation.					
17. Key Words (Suggested by Author(s)) Space power Solar dynamic Space Station Freedom			18. Distribution Statement Unclassified - Unlimited Subject Category 20		
19. Security Classif. (of this report) Unclassified		20. Security Classif. (of this page) Unclassified		21. No of pages 24	22. Price* A03