

NASA Technical Memorandum 101463

Fire Safety Applications for Spacecraft

Robert Friedman and Sandra L. Olson
Lewis Research Center
Cleveland, Ohio

(NASA-TM-101463) FIRE SAFETY APPLICATIONS
FOR SPACECRAFT (NASA. Lewis Research
Center) 29 p CSCL 22B

N 89-244 13

Unclas
G3/16 0217631

Prepared for the
Symposium on Aircraft Fire Safety
sponsored by the AGARD/NATO Propulsion Energetics Panel
Sintra, Portugal, May 22-26, 1989

NASA

FIRE SAFETY APPLICATIONS FOR SPACECRAFT

Robert Friedman and Sandra L. Olson
National Aeronautics and Space Administration
Lewis Research Center
Cleveland, Ohio 44135
U.S.A.

SUMMARY

This paper reviews fire safety for spacecraft by first describing current practices, many of which are adapted directly from aircraft. The paper then discusses current analyses and experimental knowledge in low-gravity combustion, with implications for fire safety. In orbiting spacecraft, the detection and suppression of flames are strongly affected by the large reduction in buoyant flows under low gravity. Generally, combustion intensity is reduced in low gravity. There are some notable exceptions, however, one example being the strong enhancement of flames by low-velocity ventilation flows in space. Finally, the paper examines the future requirements in fire safety, particularly the needs of long-duration space stations in fire prevention, detection, extinguishment, and atmospheric control. The goal of spacecraft fire-safety investigations is the establishment of trade-offs that promote maximum safety without hampering the useful human and scientific activities in space.

INTRODUCTION

Fire is regarded as one of the most serious threats to space travel, yet the spread of fire in space is not well understood. Efforts to prevent and control fires in space have, to a large extent, been based on techniques borrowed from aircraft practices. Indeed, fire potential in ground, launch, and recovery operations for space is analogous to that in ground servicing, take-off, and landing operations for aircraft. Thus, present spacecraft fire safety has been promoted through strict control of materials and atmospheres and through fire detection and suppression methods optimized for reliability and mass and energy conservation.

For space missions of the near future, fire safety techniques must change from simple strategies borrowed from aircraft practices to specific methods for spacecraft, compatible with the requirements of complex, multi-mission operations. The next generation of human-crew spacecraft will be dominated by permanently orbiting platforms such as the prototype U.S.S.R. Mir or the planned U.S. Space Station Freedom. The future space stations will be clusters of living quarters, laboratories, satellite launch and recovery facilities, and industrial pilot plants, accommodating "passengers" who are scientists and observers, not astronauts. Fire-safety techniques will strive for simplicity, standardization, practicality, minimal impact on operations, and reasonable costs. The similarity of these objectives to present policies in the passenger-carrying airplane fleet is inescapable.

An AGARD symposium held 14 years ago summarized the progress in aviation fire safety at that time (Ref. 1). Some of the concerns discussed at the symposium are now interests common to spacecraft and aircraft, including the needs

for better understanding of fundamental fire-safety principles, improvements in nonflammable materials, and the reduction of fire-generated smoke and toxic products. These specific concerns for spacecraft fire safety have been discussed in a symposium held in the United States, aimed at initiating studies applicable to the U.S. Space Station Freedom (Refs. 2 and 3).

This paper is a review and status report on current understanding and research directions in spacecraft fire safety. In addition to the aforementioned similarities to the aircraft environment, the paper discusses the unique attributes of space, the most obvious of which is the almost complete absence of the gravitational force. The behavior of flames in "microgravity" has a strong influence on fire initiation and control. The paper also surveys the application of low-gravity combustion knowledge to provide techniques of fire prevention, detection, extinguishment, and atmospheric control in spacecraft.

CURRENT SPACECRAFT FIRE-SAFETY PRACTICES

Fire Prevention in Space

Basic strategies. - Safety in human space travel has always been of paramount importance. The earliest space missions attempted to minimize fire hazards through stringent control of potential flammables and sources of ignition energy. Since space vehicles were relatively simple and their operating missions short in duration, the strategy of strict preclusion of fire-causing elements was thus practical to implement. For new generations of space missions, this approach of "complete exclusion" for fire safety is impractical. First, a lack of thorough understanding of fire behavior under space conditions undermines the confidence that hazards can be completely eliminated. Second and more important, regardless of the state of knowledge, space planners now concede that complete elimination of fire-causing elements is neither practical nor desirable if a space mission is to serve a variety of useful purposes in terms of passenger, scientific, or commercial accommodations (Refs. 3 and 4). Thus, total elimination of risk is impossible, and spacecraft fire safety becomes part of an optimum balance among safety, performance, cost, and schedule (Refs. 5 and 6).

Figure 1 represents a logical approach to spacecraft fire safety based on practical strategies. The goals of risk reduction are approached through the acceptability criteria, which include safety standards, material test limits, operational procedures, and other factors that limit the degree of risk. The information contributing to these acceptability decisions is provided by the identification and assessment of hazards and the formulation of tolerance standards to set a policy of risk limits.

Friedman and Sacksteder (Ref. 6) have further characterized the process of risk assessment by defining simple steps of prevention, response, and recovery, based in part on the analyses of Percy and Raasch (Ref. 7). In brief, prevention is the original philosophy of fire safety through the strict exclusion of fire-causing elements. Where prevention is impractical, response, that is, the identification of the hazard and the limitation of the growth of an incipient fire through detection and suppression techniques is a lesser risk option than full-scale fire control. Recovery, on the other hand, is the highest-risk option of fighting an established fire, limiting damage, and restoring the original conditions. Spacecraft risk management, out of necessity, incorporates this entire range of risk assessment into fire-safety programs.

Material flammability and acceptance. - The first line of defense in spacecraft fire safety is in the limitation of materials, as far as practical, to those characterized as nonflammable. For U.S. spacecraft, the primary acceptance test is the upward flammability test, described in the NASA Handbook NHB 8060.1B (Ref. 8). The apparatus is sketched in Fig. 2. The sample material, a sheet or fabric for example, is mounted vertically and ignited at the bottom. To pass the test, the material either resists ignition or, if ignited, must not sustain a flame propagating more than a stated limit (15 cm at present). Furthermore, the ignited specimen must not drip sufficiently to ignite a sheet of paper mounted below the sample. Alternative acceptance tests are defined for flammability determination of such materials as wire insulation, sealants, greases, and liquids that are unsuitable for evaluation in the upward flammability test.

Cole (Ref. 9) notes that for confidence in the results of these tests, it is critical to test material samples representative of their end-use configuration in spacecraft and to test them in the same atmosphere as to be used in space. Since fire behavior is surely different in space than in normal gravity, the safety factors provided by the normal-gravity flammability test data are uncertain. In addition, one must realize that many essential items that will be used in spacecraft, items including some clothing, paper, and films, are inherently flammable. The acceptance of these materials into a space environment assumes that their potential hazards are reduced through limitations of quantity and requirements for specialized spacing, barriers, and storage.

Fire Detection Practices in Spacecraft

Detection of fire, or its precursor overheating, depends on the ability to recognize the abnormal departure in environmental conditions known as a "fire signature" through measurement of temperature, radiation, smoke-particle, or chemical-specie changes. Knowledge of low-gravity fire behavior leads one to expect that fire indicators in space are different from those in normal gravity, both in the nature of the signature and in the mode of transport of the signature to the detector sensor (Ref. 3).

Nevertheless, present fire detectors in spacecraft are adaptations of acceptable models used on aircraft. Aircraft fire detection techniques, a subject well reviewed in recent years (Refs. 10 to 12), incorporate several modes of detection, such as temperature sensing in engine nacelles and cargo areas, and radiation and smoke-particle detectors in cabin areas. The original spacecraft fire detectors were the human crew, who could sense and detect incipient fires. The complexity and varied missions of present spacecraft, however, make remote sensing necessary.

Figure 3 shows the fire-protection provisions in the U.S. Shuttle cabin, and the inset shows a typical detector. Nine ionization-type smoke detectors are installed in the instrument bays and crew decks of the Shuttle (Refs. 9 and 13). Similar fire protection is provided in the Spacelab, which is a European Space Agency laboratory chamber installed in the Shuttle payload bay in selected missions. The Shuttle smoke detector is identical in principle to conventional aircraft and commercial ionization smoke detectors, except for two additional features. The Shuttle smoke detector is provided with a built-in fan to assure a continuous flow of sampled atmosphere. The smoke detector also has a fine screen upstream of the ionization chamber to bypass larger particles

and assure the entry of only submicrometer-sized particles into the chamber. Thus, the spacecraft smoke detector can monitor air quality regardless of location, since it maintains a continuous forced-convection flow through its sensing elements. The sampling screen is intended to reject large particles, most likely dust, to reduce the number of false alarms caused by these air-borne particles.

The present spacecraft fire detectors represent the best application of the state-of-the-art derived from aircraft and ground experience. The detectors are an outgrowth of prior investigations of several proposed techniques, including ultraviolet radiation, cloud chambers, quartz-crystal impact microbalances, and gas samplers, for smoke and fire detection (Ref. 6). While the modified ionization smoke detector represents an optimum in terms of reliability, maintenance, minimum mass and cost factors, it cannot be claimed to be the most effective for low-gravity performance. In fact, several questions for future space applications must be resolved, namely, (1) is the screened particle-size range most representative of smoke-particle densities generated in incipient space fires? (2) do the placement and internal flow performance of the detectors ensure early detection and rapid response times? and (3) how can the sensitivity and performance of the detector be checked and calibrated under space conditions?

Fire Extinguishment Practices in Spacecraft

In space, techniques for fire suppression may differ from those in normal-gravity situations both because of the unusual characteristics of low-gravity fires and because of the low-gravity influence on extinguishment delivery systems. As is the case for fire detection, present spacecraft fire extinguishers are adaptations of those used in aircraft cabin protection and employ mixed-phase extinguishants (foams) or, more commonly, pressurized gases (Refs. 10 and 14).

The early human-crew spacecraft had provisions for use of food-reconstitution water guns for emergency fire extinguishment (Ref. 9). The Skylab, the 1973-1974 U.S. prototype space station, was equipped with water/foam fire extinguishers. At present, the Shuttle fire extinguishers are pressurized gas cylinders, charged with bromotrifluoromethane (Halon 1301) (Fig. 4). Three fixed-position extinguisher cylinders protect the instrument bays, and these may be actuated remotely from the control deck. Additional portable fire extinguishers are available for fire fighting in the Shuttle cabin and also in Spacelab. These portable units can be used to suppress fires originating behind the instrument panels by inserting the extinguisher nozzles into ports in the panels.

The choice of Halon 1301 for fire protection in the Shuttle is based on the demonstrated effectiveness of this extinguishant (a small concentration extinguishes most fires) as well as on its inertness, at least in small concentrations. There are, however, recognized disadvantages in the use of Halon 1301, even for aircraft service (Refs. 12 and 14). The principal problem is that Halon 1301 extinguishes by inhibiting the chain-branching reactions of combustion and, in the process, generates hydrogen halides (HBr and HF). These gases are toxic and corrosive, and they can be difficult to remove in the recycling environmental control system. Furthermore, Halon 1301 is relatively

ineffective on deep-seated or smoldering fires, which require cooling or smothering foams for suppression. The occurrence of smoldering fires may be reasonably probable in space, where the slow diffusion of oxygen into porous media favors smoldering rather than flaming combustion.

A number of common extinguishing agents have been suggested as alternatives to Halon 1301 in future spacecraft (Refs. 1 and 4), but each has disadvantages as well as advantages. A primary consideration in the selection of an extinguishing agent is the effect of the potential contamination of the spacecraft atmosphere by the agent and its reaction products. The provision for Halon 1301 onboard the U.S. Shuttle is justified in that, for a short-duration mission, the advantages of the Halon overcome its disadvantages. A discharge of the extinguishant during a mission would call for an immediate termination and return to earth within a few hours to minimize the toxic or corrosive effects (Ref. 13). This option is not available in future, permanent orbit missions, as in Freedom.

COMBUSTION AND FIRE IN SPACE

The Low-Gravity Environment

At the usual altitude of a few hundred kilometers for human-crew orbiting spacecraft, the Earth gravitational acceleration is little different from that at sea level (9.8 m/s^2). The condition of the spacecraft and its contents is that of free fall, where there is a balance of forces with a very low net acceleration force. Zero acceleration, or zero gravity, is approached only as a limit. In practice, accelerations due to unbalanced drag forces and other perturbations are slight, of the order of 10^{-7} to 10^{-4} times normal Earth gravity. For combustion research, this low-gravity environment is usually called microgravity.

The large temperature differences in flames cause density differences, which produce strong upward, buoyant flows in normal gravity. In low gravity, flame propagation is no longer preferentially "up," and diffusion, Stefan and other transport mechanisms, whose effects are overwhelmed by buoyancy in normal gravity, can strongly influence flame propagation. Transport of heat by radiation may become dominant, causing flame inhibition by cooling in some instances, causing fire propagation to adjacent surfaces in other instances. The transport of oxygen to a flame zone by diffusion alone may be slow and inefficient in low-gravity flames, altering the chemistry and kinetics of the combustion reaction. All these factors can strongly affect the ignition, spread, and nature of the reduced-gravity flame.

Thus, fire safety in orbiting spacecraft requires foremost an understanding of the behavior of combustion processes in low gravity, based on theoretical analyses and validating experimental data.

Brief History of Low-Gravity Combustion Research

The earliest low-gravity combustion experiments conducted with solid materials were performed aboard aircraft flying over parabolic flight paths to obtain short periods of low gravity (Ref. 15). Various polymeric materials, rubber compounds, paraffins, and paper were burned in low-pressure, pure-oxygen environments. Burning rates in low gravity were observed to be slow, but steady-state conditions were not achieved during the short test time.

Subsequent aircraft experiments (Ref. 16) were conducted to study the burning rates of cotton cloth strips under various oxygen-diluent atmospheres. Burning rates were observed to increase with increasing thermal conductivity of the inert diluent but were overall much lower in low gravity than in normal gravity. Momentary slight accelerations were observed to increase the burning rates considerably, but again the effect could not be quantified because steady-state was not achieved.

A series of drop tower experiments were conducted in the early 1970's (Refs. 17 to 19) to examine the effects of oxygen concentration and pressure on the burning rates of cellulose acetate. These test results indicated that low-gravity flame-spread rates are nearly the same, or slightly lower, than normal-gravity spread rates and are a function of material thickness. The flame-spread rate of the thinnest materials is comparable to normal-gravity rates, but the rates of thick materials are considerably less than those in normal gravity.

The only on-orbit combustion experiments to date were direct continuations of the early aircraft tests. Aluminized mylar, nylon, neoprene-coated nylon fabric, polyurethane foam, paper, and Teflon fabric were studied aboard Skylab 4 in 1974 (Ref. 20), in a 0.04-cubic meter spherical combustion apparatus (Fig. 5). In addition to tests of the burning rates of the materials noted, the Skylab experiments studied the spread of fire to adjacent materials as well as the extinguishment of the burning material through water sprays or venting to the vacuum of space. Qualitative results from these tests were recorded by a 16-mm color movie camera. Burning rates were observed in general to be much slower in low gravity than in normal gravity. Figure 6 shows the spherical flame generated by burning a polyurethane sample in low gravity. Fires were observed to spread from one material to another over a gap of 1.3 cm. In the venting tests, it was noted that air flow caused by evacuation of the atmosphere greatly intensifies the burning rates for a brief period of time before causing extinguishment in the near-vacuum. It was concluded from this observation that, unless the evacuation time is short, the enhanced combustion due to the air motion could do considerable damage before extinction occurred. Water extinguishment was successful in some cases. However, when the water spray was not carefully dispersed, the water was observed to scatter burning materials rather than extinguish them.

Based upon these simple low-gravity combustion tests, Kimzey observed that, because low-gravity burning rates are slower and show no tendency to increase with time as is usual in normal-gravity upward burning, normal-gravity flammability tests (Ref. 8) provide adequate, conservative standards for low-gravity material acceptance. Recently, the sufficiency of normal-gravity tests to characterize low-gravity flammability has been questioned. Of particular concern is the observation from the early tests that, if some convection is imposed on the burning material in low gravity (due to accelerations, venting, or air circulation), the burning rate intensifies considerably. The U.S. Shuttle and Space Station Freedom must have air circulation systems to provide a constant flow of air through the cabin; and, as an example, the Shuttle closed-loop air circulation system provides nominal air velocities between 8 and 20 cm/s throughout the crew cabin (Ref. 21). Thus, as the fire-detection systems and extinguishment systems are being designed for Freedom, further knowledge of the hazards of fire in space is essential.

In response to this renewed concern, a comprehensive, continuing experimental and model development program is being conducted to study the effects of oxygen concentration, material thickness, and flow on combustion of materials in low and partial-gravity environments. Figure 7 shows the evolution of experimental hardware to study solid-material flammability in low gravity. The airplane test package was the earliest apparatus (Ref. 15), which served as a model for the Skylab tests cited here. The drop-tower package is an apparatus currently in use at the U.S. NASA Lewis Research Center to study effects of atmospheres, inertants, and ventilation flow on paper combustion. The Solid Surface Combustion Experiment (Ref. 22) is a flight package designed for long-duration tests in the Shuttle, scheduled to fly at the earliest opportunity, probably in 1990.

Low-Gravity Combustion Parameters of Concern for Fire Safety

The modeling and experimental results to date have given an improved understanding of what factors are important in assessing the fire hazard in a low-gravity environment. To illustrate, typical normal and low-gravity flames in thin solid fuels are drawn schematically in Fig. 8. In general, the flames in low gravity are observed to be cooler and more diffuse than their normal-gravity counterparts. The flame is larger and establishes itself further from the fuel surface than normal-gravity flames. Large soot particles are seen to escape from the flame zone in low gravity, and the color of these radiant particles change as they cool, from orange to dull red to black (Ref. 23).

Material properties. - Material properties play an important role in the combustion process in low gravity. Materials that melt as they burn may boil at their surface, and the pulsating flame that results is due to the unsteady rate of vaporization from the boiling fuel. Nylon samples in the Skylab tests (Ref. 20) and nylon velcro in drop tower tests (Ref. 24) were observed to burn in this manner. The viscosity of the solid-fuel melt could also be a factor in the hazard of fire spread, because gaseous bubbles breaking through the liquid surface can propel molten and burning chunks of fuel into the gas phase to drift away until they impact on another (possibly flammable) surface. The expulsion of burning droplets of molten fuel has been observed in drop tower tests with nylon Velcro. Figure 9 shows a photograph of burning droplets leaving the flame zone of the burning material, along with a sketch interpreting the photograph. Droplet expulsion appears to be enhanced by a slow air motion past the sample, which also increases the overall burning rate considerably (Ref. 24).

Another material property which has been found to be important in low gravity combustion is the material thickness. In normal gravity, the flame-spread rate varies inversely with material thickness throughout the flammability region. In low gravity, the same relationship holds except near the extinction limit (minimum oxygen concentration) where the flame-spread rate for these flames decreases more strongly with increasing material thickness (Ref. 25). Further studies are needed, however, to quantify the thickness effect in low gravity more completely.

Atmospheric composition. - Inert gases such as nitrogen also have an important role in the burning process. It is known from normal-gravity testing that, for a constant partial pressure of oxygen, flammability decreases if the total pressure is increased by adding atmospheric diluent. This is because the

combustion energy absorbed in heating the inert gas reduces the flame temperature. Therefore, although it has yet to be studied comprehensively in low gravity, inert pressurization with high heat-capacity gases appears to be an excellent candidate for fire prevention.

Inert gases also affect the combustion process by acting as a heat transfer medium from the flame to the fuel. Normal and low-gravity experiments have demonstrated that the thermal conductivity of the inert gas directly affects the burning rate; the higher the thermal conductivity, the faster the material will burn. Helium, for example, transfers heat very rapidly, and so materials in a helium-oxygen environment burn more quickly than the same materials in comparable nitrogen-oxygen environments. Thus it is desirable for further research in fire prevention, to consider diluents with a high heat capacity but a low thermal conductivity.

Oxygen concentration in the environment has probably been the most studied parameter in low-gravity combustion research. The early tests focused on low-pressure, high-oxygen-concentration atmospheres because these atmospheres corresponded to the spacecraft practice at that time. U.S. human-crew spacecraft since the Apollo era have been designed for a low-oxygen concentration to reduce the fire hazard. The Shuttle currently uses standard sea-level air as its baseline atmosphere, although an elevated oxygen atmosphere is introduced in preparation for extravehicular activities.

Increasing oxygen concentration increases the burning rates of most, if not all, solid materials. Figure 10 shows how the flame-spread rate for paper changes as the oxygen concentration is increased (Ref. 25). For flames in high-oxygen concentrations far from the extinction limit, normal and low-gravity flame-spread rates are identical and linear with oxygen concentration; gravity plays no discernible role in the flame-spread process. Near the extinction limit, however, flame-spread rates decrease rapidly with decreasing oxygen concentration; and the low-gravity flame-spread rates are lower than the normal-gravity counterpart rates.

Radiation and extinction limits. - The data illustrated in Fig. 10 show the extinction limits in both normal gravity and low gravity. The cause of extinction is believed to be different for the two gravity situations. In normal gravity, flame extinction is usually caused by "blowoff," or the excessive gravity-induced convective removal of heat, usually due to buoyant flows. Blowoff occurs, for example, when you blow out a match. In low gravity, however, there are no gravity-induced convection flows, but the cooler flames are more sensitive to heat losses than normal-gravity flames. Experimental results suggest that radiative heat loss from the burning fuel surface, or quenching (i.e., rapid cooling), is the probable cause of extinction in low gravity (Ref. 23).

Convective heat transfer in low gravity is greatly reduced because of the elimination of buoyancy-induced flows, and conductive heat transfer appears to be reduced because flames are observed to be further from the fuel surface. Thus the relative importance of radiative heat transfer, either from the solid surface or from the flame zone, is greater. Radiative heat transfer can, as postulated above, cause flame extinction, or it can cause ignition of a fuel surface in the absence of convective cooling.

Ventilation and forced convection. - In the absence of buoyant flow, the dominant flow imposed upon a burning surface in spacecraft would be due to the ventilation system. The early low-gravity tests indicated that flow enhances combustion, and more recent quantitative tests have supported these early qualitative results (Refs. 23, 26, and 27). Figure 11 is a summary of the effect of air velocity on the flame-spread rate over paper. At near-quiescent conditions, attainable only at low gravity, the flame-spread rate is low. As the air velocity is increased in a direction counter to the flame spread, fresh oxygen is brought into the flame zone by forced convection; and the flame-spread rate increases rapidly with air velocity. On the other hand, at high air velocities typical of buoyancy-driven normal-gravity air velocities, the flame-spread rate decreases with increasing air velocity due to "blowoff," the convective cooling and dilution of the flame zone. The important concern for fire safety is in the range of intermediate velocities where flame-spread rates can be greater than the typical normal-gravity flame-spread rate. While the quantitative extent of this enhanced flame-spread-rate zone is not fully defined by experiments, it appears to lie within the range of typical spacecraft ventilation-air velocities.

Figure 12 describes the air-velocity effects as a flammability map for paper, which indicates the atmospheric conditions (oxygen concentration and flow velocity) over which the material will or will not burn. As is the case for flame-spread rates shown in Fig. 11, flammability increases (lower oxygen limits) at low air velocities, typical of low gravity, but decreases at high air velocities, typical of normal gravity with buoyant flow. Again, the maximum fire hazard for paper appears to be at intermediate forced-flow velocities attained in low gravity (in the range of current Shuttle ventilation velocities). Under these conditions, the material may burn at oxygen concentrations as low as 15 percent, which is below the measured downward-spread flammability limit in normal gravity with no forced convection.

Application of Low-Gravity Combustion Knowledge to Fire Safety

Much has been done since the Apollo era to improve the safety of spacecraft. The major improvement in the fire safety area has been to reduce the oxygen concentration from pure oxygen to that of sea-level air. Although humans can tolerate even lower oxygen atmospheres, reducing the oxygen concentration below that of air can adversely affect the mission usefulness, in terms of passengers, scientific, and commercial accommodation.

The reduction of oxygen concentration to that of air was an obvious improvement because this is the normal baseline atmosphere; and most, if not all, materials are more flammable in higher oxygen concentrations. Other fire-safety changes are not as feasible for adaptation. For example, the thicker the material the slower it burns, so it would seem to be logical to use potentially flammable materials in as thick a section as practical. However, this design concept is inconsistent with a common-sense approach of limiting the total quantity of flammable materials.

Actual low-gravity testing of all materials to fly in space is obviously not feasible at present. Current test methods reflect our understanding of flammability in normal gravity, but they fail to include some of the unique hazards associated with low gravity. These concerns include the enhanced low-gravity burning rate associated with forced-convection flows, the spread

of fire by expulsion of hot particles from melting plastics, and the flammable, persistent aerosols created by spills of fluids or powders. In addition, some assessment of the potential for smoldering must be devised. Smoldering solids may burn undetected for hours or days, and even if flaming combustion never occurs, the build up of toxic products in the atmosphere is a serious danger to the environmental-control and life-support system.

Furthermore, investigation of the influence of low-gravity combustion processes on fire detection and fire extinguishment is needed for intelligent protection of the long-term habitation environments in space. Potential designs for fire detectors and fire extinguishers need to be tested in real low-gravity fire situations. Application of low-gravity combustion knowledge can also influence operational procedures to determine what improvements can be made to reduce the fire hazard while minimizing the inconvenience of safety regulations on the day-to-day activities of the crew.

FIRE SAFETY FOR FUTURE SPACECRAFT

The U.S. Space Station Freedom

Freedom, a permanent vehicle in low earth orbit, is a space station to be placed in operation in the next decade. Freedom is conceived as a cluster of elements devoted to satellite servicing, scientific and commercial space activities, and long-duration human habitation. The center of Freedom is the grouping of modules with interconnecting nodes and airlocks (Fig. 13). The main components are the habitation module for a crew of perhaps eight persons, the supply module, and three laboratory (and workshop) modules, with projects and personnel from several NATO nations and Japan, as well as the U.S.

The permanent installation and long-duration missions of Freedom will increase the probability of the occurrence of a fire. Since rescue and resupply flights cannot be immediately available, perhaps taking 30 days or longer to arrange, safety planning must assume that all fire controls and recovery supplies are contained within Freedom. In this respect, the interconnecting, "ladder" arrangement of the modules (Fig. 13) assures at least two paths of egress from each module, a haven for the crew in any node, and a means of closing off a damaged module without blocking access to any other module or node.

As stated earlier, the goal of fire safety in Freedom is the minimization of risk, rather than zero risk. That is, small tolerable threats are balanced against the constraints of practicality, operations, and economics (Refs. 5 and 6). A space station must accommodate living and recreational activities, as well as scientific and industrial operations, all of which require the possible introduction of flammable materials, heating and energetic operations with no satisfactory substitutes. The challenge to spacecraft fire-safety designs and techniques is obvious.

Submarine and Aircraft Analogies

Spacecraft fire-safety practices have been modeled on, and will continue to derive from, techniques and experiences established for the enclosed compartments of aircraft and submarines (Ref. 28). The submarine operates in a hostile external environment, supplies its own recycled atmosphere, and depends

on self-contained fire detection and suppression systems. The spacecraft, however, has obvious differences because of its low-gravity exposure and the inability to extract oxygen from the surrounding atmosphere. (Submarines can generate oxygen from sea water.) In addition, submarines may surface for personnel evacuation if a fire becomes wide spread.

One set of submarine fire-protection investigations of interest for potential spacecraft application is that of fire-safe atmospheres. The small-scale combustion studies promoting low-oxygen atmospheres for fire prevention have already been discussed in a previous section. Gann et al. (Ref. 29) described simulation-chamber tests of nitrogen flooding for submarine fire fighting, where excess nitrogen lowers the oxygen content while retaining the oxygen partial pressure at tolerable levels for humans. An alternative approach, more suitable for spacecraft applications, is to maintain a constant total pressure with a reduced oxygen partial-pressure level based on minimum levels from high-altitude human experience. Allowable limits for low-oxygen atmospheres have been discussed by Horrigan (Ref. 30), and the fire-protection aspects have been presented in a spacecraft atmosphere selection forum summarized in Ref. 1. Another alternative method involves the substitution of a high molar-heat-capacity inert gas, such as CF_4 or SF_6 , for nitrogen in the atmosphere (Ref. 31). The diluent will suppress combustion by lowering the flame temperature. Nevertheless, the use of fire-safe atmospheres on spacecraft must await the definition and implementation of long-duration testing of human responses and efficiency in the respective atmospheres. In any event, there are formidable structural and operational difficulties to the general adoption of atmospheres other than "air" in future spacecraft.

Of greater interest, however, is the use of inerting atmospheres in specific, uninhabited volumes, such as in electrical power cabinets. A promising source of an inerting atmosphere, already under investigation for military-aircraft fuel-tank inerting, is onboard inert-gas generation. This technique involves the removal of some of the atmospheric oxygen by molecular-sieve or permeable-membrane separators (Refs. 32 and 33). In spacecraft practice, an inert gas retaining 6 percent or greater oxygen concentration may be effectively fire-safe. In contrast to the once-through aircraft inerting system, the gases from the spacecraft inerting system would be recycled, and both the inert gas and the separated oxygen would be recovered and combined to regenerate part of the breathing atmosphere.

Research and Technology Trends

Fire prevention. - Adequate screening of materials for onboard use has been a long-time concern for both aircraft and spacecraft, and this concern has spurred the development of new plastic and composite materials with low-flammability characteristics. The principal acceptance test for NASA spacecraft materials, the upward propagation test (Fig. 2), has already been described in this paper. In low gravity, since flammability is often reduced for solid materials, the normal-gravity test may offer an adequate margin of safety for spacecraft acceptance. There may be exceptions to this supposition, however. For example, the low-gravity tests on Velcro specimens, already cited (Ref. 24), showed that the random expulsion of hot particles from burning plastics may create an additional ignition hazard in space. It has also been noted that low-gravity combustion may be greatly enhanced by even low levels of ventilation air flows. At present, however, the correlation of small-scale test

results to the ventilation-flow environment of the Space Station Freedom, for example, is unknown. Thus, it is important to continue research on low-gravity combustion with the major objective of providing understanding of processes to establish safety levels for long-duration space station needs. In addition, fire-risk analyses for space must assume that, even if satisfactory assessments of low-gravity flammability are defined, some flammable materials will still have to be tolerated onboard Freedom because many useful human and scientific activities require hazardous materials and procedures. Fire-safety strategies will approach fire prevention through compartmental inerting, fire-safe storage, configuration controls, and material quantity and separation minimums. As the second line of defense, provisions for fire detection and extinguishment, which assume the probability of an incipient fire, become of great importance.

Fire detection. - Spacecraft specialists are aware that present fire-detection techniques, while adequate for the short-duration Shuttle missions, require considerably more knowledge and development for space-station applications. Obviously, one requirement is more information on expected fire signatures under low gravity. As noted earlier in this paper, studies show that low-gravity flames are generally cooler, sootier, and slower propagating than their normal-gravity counterparts, and these characteristics affect the techniques of detection. It appears that smoldering combustion may be possible in space, because the slow transport of oxygen into porous media (foams, waste containers) can promote this rather than flaming combustion. Smoldering combustion generates large smoke particles, and detectors would have to be tuned to recognize these particles as fire signatures. Finally, the transport of various fire signatures is also changed in low gravity. Since it is impractical to instrument space modules completely, a limited number of fire detectors must be judiciously placed to intercept the most probable pathways of fire-signature agents.

Placement of fire detectors planned for Space Station Freedom can take advantage of ventilation ducting for efficient monitoring of the atmosphere and potential fire radiation. The type and design of sensors are still under discussion, and it is likely that fire protection in Freedom will incorporate sensors of several generic types. Thus, the complete fire-detector system would include smoke, chemical, radiation, and overheat sensors, whose coverage could be augmented by extensions, such as rotating mirrors, fibers optics, or sampling tubes.

Adequate sensitivity of fire detectors is a problem common to ground and aircraft systems. Fire detectors must respond to minimum fire-signature thresholds yet reject extraneous signals that cause false alarms. An extensive survey of commercial experience cites a 14 to 1 ratio of false alarms from smoking, cooking, dust, and so on, to real alarms in smoke detectors (Ref. 34). Thus, promising approaches for high-sensitivity detector systems less prone to false alarms may incorporate multiple sensors with decision logic to define the alarm conditions with adjustable sensitivities (Refs. 6 and 12).

Fire extinguishment. - A parallel concern for spacecraft fire extinguishment arises from the evidence that the Halon 1301 fire extinguisher, while adequate for the short-duration Shuttle missions, requires considerable improvement or replacement for space-station applications. In long-duration spacecraft, the environmental problems with the use of Halons are of great concern.

An ideal, substitute low-gravity extinguishant should be effective (minimum quantity required) for all anticipated fire scenarios, convenient for delivery to the fire, and readily removable, in both its original and reacted states, from the atmosphere.

Several types of extinguishing systems are being considered for future spacecraft. For example, deionized water and foam systems have been proposed for further study in recent review papers (Refs. 1 and 4). Water is efficient as an extinguishant, creates no undesirable reaction products, and is readily removable from the atmosphere. The effective control and dispersment of water sprays in low gravity are formidable technology problems, however. A more practical approach employs gaseous extinguishers, and carbon dioxide is favored in the initial plan for Space Station Freedom. The strong advantage of carbon dioxide is that it is readily removable by any spacecraft environmental control system. Carbon dioxide is recognized, however, as a relatively inefficient extinguishant, and the large concentration required for effective fire suppression may be hazardous to the crew as an asphyxiant (Refs. 32 and 35). The same arguments may support or disqualify nitrogen as a fire extinguishant, although nitrogen is an ideal diluent for inerting of uninhabited compartments, a technique already discussed.

Venting to the vacuum of space is an ultimate fire-extinguishing method available to spacecraft. A difficult fire can be completely controlled by venting after the escape of the crew and sealing of the fire-stricken compartment. Venting need only proceed to a point where the retained oxygen partial pressure is low enough to suppress combustion, which makes later reconstitution of the atmosphere less demanding. The small-scale Skylab experiments of Kimzey (Ref. 15), cited in a previous section, showed that the air motion induced by venting can temporarily increase flame spread and may cause additional fire damage before the fire is extinguished.

Human factors. - The completely closed cycle and limited resupply capabilities in spacecraft atmospheres cause the threat of contamination to be greatly feared, even more so than in the closed-environment counterparts of submarines and aircraft. For Space Station Freedom, evaluation and selection of fire-control systems will depend strongly on internal environmental impacts. In summary, it is important to emphasize that the greatest danger from fire, its precursors (overheating, pyrolysis, and smoldering) and its extinguishment, lies in the toxicity of the products and not in the thermal effects or structural damage. Human responses, including safety enforcement, fire drills, escape modes, and rescue may be modeled to a great extent on practices established for aircraft. Important decisions in future spacecraft planning will be on the relative reliance on manual versus automated responses. As spacecraft and their missions become more complex, there is a greater need to invest in automatic systems for protection of unattended compartments and to insure rapid and predictable responses to emergencies. Nevertheless, strong arguments can be advanced to retain many human-detection options. The value of Space Station Freedom is increased if users are confident that irreplaceable projects are protected not only from fire effects but also from damage through inadvertent shutdown or false-alarm extinguishant release.

Fire-Safety Research in Space

As discussed earlier, analytical modeling and simulation-facility experiments are necessary and valuable for small-scale studies of microgravity combustion pertinent to fire-safety understanding. What is lacking, of course, is the capability to conduct low-gravity, long-duration tests on, for example, material flammability, smoldering, fire-signature identification, detector response and calibration, extinguishant delivery and effectiveness, and human response modes. The U.S. Shuttle incorporates the best available technology in its fire detection and suppression systems. These systems cannot be verified in true space conditions, but this lack is compensated by the extremely low probability of a fire during a short-duration mission and the ability to terminate a mission and return to earth promptly. The permanent habitation and long-duration mission of the Space Station Freedom, however, present more serious problems for the development of fire-protection systems, requiring some degree of in-space testing and verifying.

As a practical matter, development and demonstration of fire prevention, detection, and suppression policies and techniques for Freedom will need a compromise to simplify validations through effective use of analytical knowledge and small-scale simulation testing. There are hopes that some timely tests and demonstrations can be conducted in future Shuttle missions up to the time of the construction and assembly of Freedom in orbit.

The Space Station Freedom itself is the ideal facility for long-duration fire-safety testing for space. The space-station laboratory modules are equipped with power, utilities, and standardized racks for mounting experiments to exploit the microgravity environment in the modules. One definition concept for installation in a Freedom laboratory module, shown in Fig. 14, consists of a combustion chamber to be mounted in one rack with associated data and power systems in an adjoining rack (Ref. 36). Such a facility, which is one of several under active design consideration by NASA, can accommodate multiple experiment functions, including investigations of ignition, flame spread, flammability, combustion products, and flame suppression.

CONCLUDING REMARKS

This paper is a review of the knowledge, techniques, and future trends in spacecraft fire safety. It is clear that aircraft fire-safety strategies and hardware serve as important models for corresponding measures in space. The overwhelming difference in space is the negligible gravitation body force, a situation that profoundly influences fires, their detection, and their control. Another operational difference affecting fire safety is that spacecraft of the future must be completely self-contained: the atmospheric, fire-fighting, and rescue resources are all maintained by the spacecraft logistic supplies.

For the present, the fire safety provisions in the U.S. Shuttle appear adequate for they are based on selected applications of proven techniques in ground and aircraft fire safety. What is lacking for continued safety in future long-duration missions is a better understanding of low-gravity combustion and its application to spacecraft fire safety. Analyses and small-scale experiments indicate that the lack of natural convection (absence of gravity-driven buoyancy) may generally inhibit combustion, producing cooler, less efficient flames. Special circumstances, in contrast, may increase fire dangers

in space. The most important is the demonstrated enhancement of low-gravity combustion by low flow rates of ventilation. Regardless of the relative danger of fire in low gravity compared to normal gravity, it is clear that the unique characteristics of fires in space require innovative techniques in fire prevention, detection, and extinguishment.

Design and research are underway for the U.S. Space Station Freedom, a multipurpose space community, to be permanently placed in a low-earth orbit. For Freedom, it is necessary to devise reasonable material flammability acceptance policies, consistent with present knowledge of space behavior. Fire detection for this spacecraft must recognize the potential fire signatures in low gravity and devise systems of adequate sensitivity yet perceptive enough to reject false alarms, with added provision for in-flight checks and calibrations. Fire extinguishment for Freedom must be efficient, suitable for operation in low gravity and, above all, uncontaminating and removable from the closed atmospheric system. Crew training and escape modes must be devised to consider the probability of fires occurring in space and their spread and hazards in low gravity.

Finally, spacecraft fire safety can no longer rely on strict rules, devised for short-term missions. Fire safety for future spacecraft, like Freedom, must be flexible and realistic, similar to policies in place for aircraft. The goal of spacecraft fire safety will be a compromise to achieve the lowest practical risk level consistent with the promotion of useful functions of habitation, science, and commercial operations in the spacecraft.

REFERENCES

1. Aircraft Fire Safety. AGARD CP-166, 1975.
2. Margle, J.M., ed.: Spacecraft Fire Safety. NASA CP-2476, 1987.
3. Friedman, R.; and Sacksteder, K.R.: Science and Technology Issues in Spacecraft Fire Safety. AIAA Paper 87-0467, Jan. 1987 (NASA TM-88933).
4. De Meis, R.: Safety in the Space Station. Aerospace America, vol. 24, no. 5, May 1983, pp. 26-29.
5. Rodney, G.A.: Safety Considerations in the Design of Manned Spaceflight Hardware. IAF Paper 87-569, International Astronautical Federation, 1982.
6. Friedman, R.; and Sacksteder, K.R.: Fire Behavior and Risk Analysis in Spacecraft. NASA TM-100944, 1988.
7. Peercy, R.L. Jr.; and Raasch, R.F.: Threat-Strategy Technique: A System Safety Tool for Advanced Design. J. Spacecraft Rockets, vol. 23, no. 2, Mar.-Apr. 1986, pp. 200-206.
8. Flammability, Odor, and Offgassing Requirements and Test Procedures for Materials in Environments that Support Combustion. NASA TM-84066, 1981 (NASA NHB-8060.1B).
9. Cole, M.B.: Space Station Internal Environmental and Safety Concerns. Spacecraft Fire Safety. J.M. Margle, ed., NASA CP-2476, 1987, pp. 73-87.

10. Botteri, B.P.: Aircraft Fire Protection Technology. Aircraft Fire Safety. AGARD CP-166, 1975, pp. 18-1 to 18-15.
11. Waldman, J.J.: Aircraft Fire and Overheat Detection and Extinguishment. SAE Paper 800622, Society of Automotive Engineers, Apr. 1980.
12. Mniszewski, K.R.; Waterman, T.E.; Campbell, J.A.; and Salzberg, F.: "Fire Management/Suppression System/Concepts Relating to Aircraft Cabin Fire Safety," FAA-CT-82-1234, Federal Aviation Administration, 1983 (Avail. NTIS, AD-A137155).
13. Kubicki, D.J.: Fire Protection and Rescue Planning for the NASA Space Shuttle. Fire Journal, vol. 75, no. 4, July 1981, pp. 34-40, 127-128.
14. Kuchta, J.M.; and Clodfelter, R.G.: Aircraft Mishap Fire Pattern Investigations. AFWAL-TR 85-2057, U.S. Air Force Wright Aeronautical Laboratories, 1985 (Avail. NTIS, AD-A161094).
15. Kimzey, J.H.; Downs, W.R.; Eldred, C.H.; and Norris, C.W.: Flammability in Zero-Gravity Environment. NASA TR R-246, 1966.
16. Neustein, R.A.; Mader, P.P.; Colombo, G.V.; and Richardson, D.E.: The Effect of Atmosphere Selection and Gravity on Burning Rate and Ignition Temperature. McDonnell Douglas Astronautics Co. Report DAC-62431. (NASA CR-106652), Oct. 1968.
17. Andracchio, C.R.; and Aydelott, J.C.: Comparison of Flame Spreading Over Thin Flat Surfaces in Normal Gravity and Weightlessness in an Oxygen Environment. NASA TM X-1992, 1970.
18. Andracchio, C.R.; and Cochran, T.H.: Burning of Solids in Oxygen Rich Environments in Normal and Reduced Gravity. NASA TM X-3055, 1974.
19. Andracchio, C.R.; and Cochran, T.H.: Gravity Effects on Flame Spreading Over Solid Surfaces. NASA TN D-8228, 1976.
20. Kimzey, J.H.: Skylab Experiment M479 Zero Gravity Flammability. Proceedings of the Third Space Processing Symposium on Skylab Results, Vol. 1, NASA TM X-70252, 1974, pp. 115-130.
21. Sauers, D.G.: The Effects of Forced Air Flow and Oxygen Concentration on Flammability, Smoke Density, and Pyrolytic Toxicity. J. Fire Flammability, vol. 7, Apr. 1976, pp. 181-199.
22. Vento, D.; Zavesky, R.; Sacksteder, K.; and Altenkirch, R.: The Solid Surface Combustion Space Shuttle Experiment - Hardware Description and Ground-Based Test Results. AIAA Paper 89-0503, Jan. 1989.
23. Olson, S.L.; Ferkul, P.V.; and T'ien, J.S.: Near-Limit Flame Spread Over a Thin Solid Fuel in Microgravity, to appear in Twenty-Second Symposium (International) on Combustion, The Combustion Institute, Pittsburgh, PA, 1989 (NASA TM-100871).
24. Olson, S.L.; and Sotos, R.G.: Combustion of Velcro in Low Gravity. NASA TM-88970, 1987.

25. Olson, S.L.: The Effect of Microgravity on Flame Spread Over a Thin Fuel. NASA TM-100195, 1987.
26. Foutch, D.W.: Size and Shape of Solid Fuel Diffusion Flames in Very Low Speed Flows. NASA CR-179576, 1987.
27. Ferkul, P.V.: An Experimental Study of Opposed Flow Diffusion Flame Extinction Over a Thin Fuel in Microgravity. NASA CR-182185, 1988.
28. Rossier, R.N.: Nuclear Powered Submarines and the Space Station: A Comparison of ECLSS Requirements. Aerospace Environmental Systems, SAE P-177, Society of Automotive Engineers, Warrendale, PA, 1986, pp. 321-329.
29. Gann, R.G.; Stone, J.P.; Tatem, P.A.; Williams, F.W.; and Carhart, H.W.: Suppression of Fires in Confined Spaces by Nitrogen Pressurization, III Extinction Limits for Liquid Pool Fires. Combust. Sci. and Technol., vol. 18, nos. 5-6, 1978, pp. 155-163.
30. Horrigan, D.J.: Atmosphere. The Physiological Basis for Spacecraft Environmental Limits, NASA RP-1045, J.M. Waligora, ed., 1979, pp. 1-15.
31. Huggett, C.: Habitable Atmospheres Which Do Not Support Combustion. Combust. Flame, vol. 20, no. 1, Feb. 1973, pp. 140-142.
32. Desmarais, L.A.; Tolle, F.F.; and Allen, T.D.: Evaluation of Advanced Airplane Fire Extinguishants. AIAA Paper 83-1141, June 1983.
33. Anderson, C.L.: Advanced Air Separation Module Performance Evaluation. AFWAL-TR-88-2031, U.S. Air Force Wright Aeronautical Labs, Wright Patterson Air Force Base, OH, July 1988.
34. Bukowski, R.W.; and Istvan, S.M.: A Survey of Field Experience with Smoke Detectors in Health Care Facilities. NBSIR 80-2130, U.S. National Bureau of Standards, Oct. 1980.
35. Gibbons, H.L.: Carbon Dioxide Hazards in General Aviation. Aviation Space Environ. Med., vol. 48, Mar. 1977, pp. 261-263.
36. Youngblood, W.W.; and Seiser, K.M.: Experiments to Ensure Space Station Fire Safety - A Challenge. AIAA Paper 88-0540, Jan. 1988.

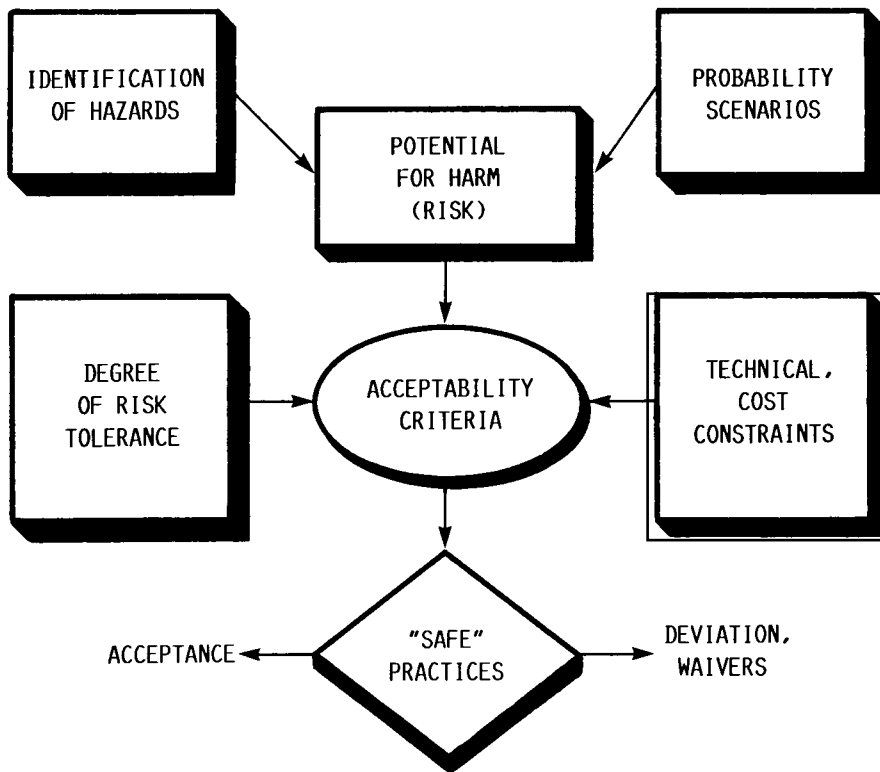

FIGURE 1. - REPRESENTATION OF SPACECRAFT SAFETY PROCEDURES.

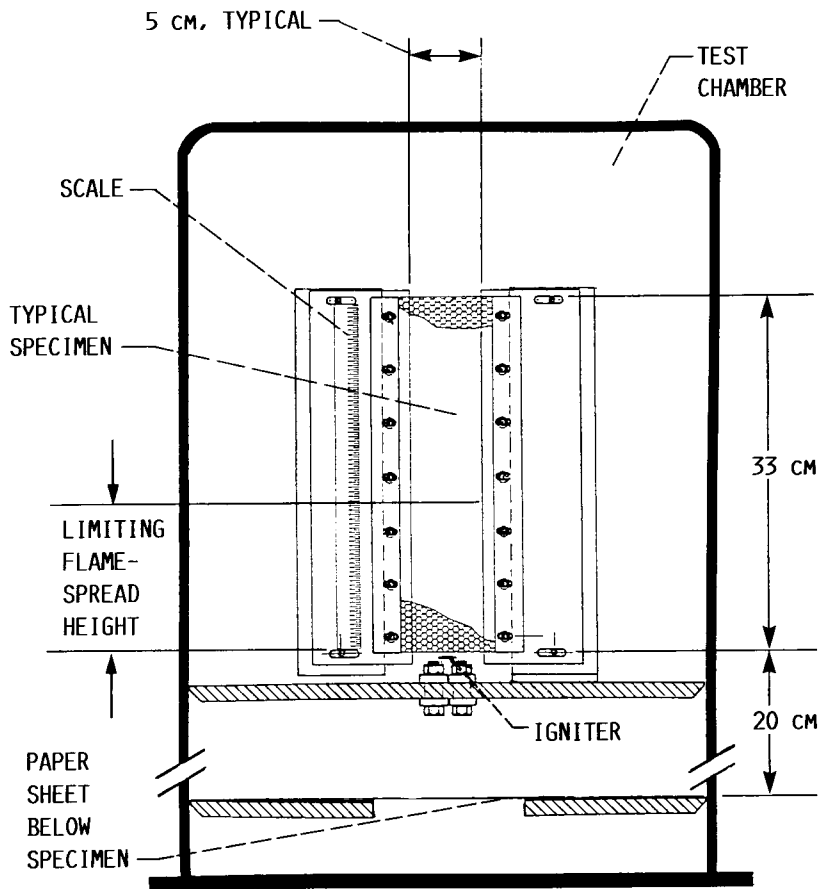

FIGURE 2. - STANDARD UPWARD BURNING TEST METHOD FOR SPACECRAFT MATERIALS.

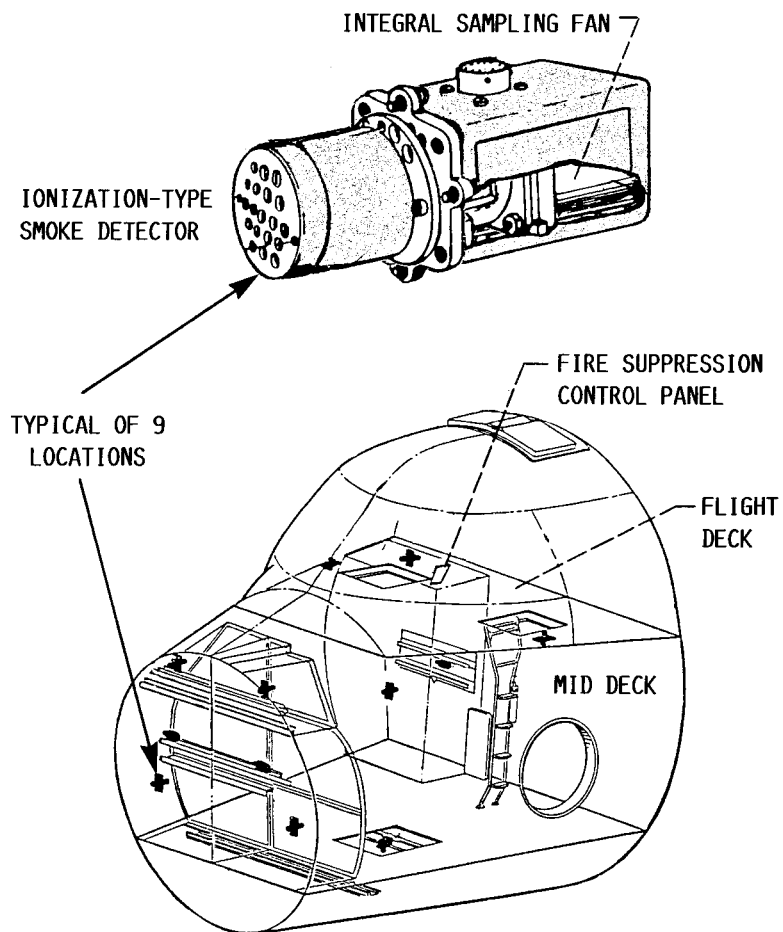

FIGURE 3. - FIRE DETECTION IN THE U.S. SHUTTLE ORBITER CABIN.

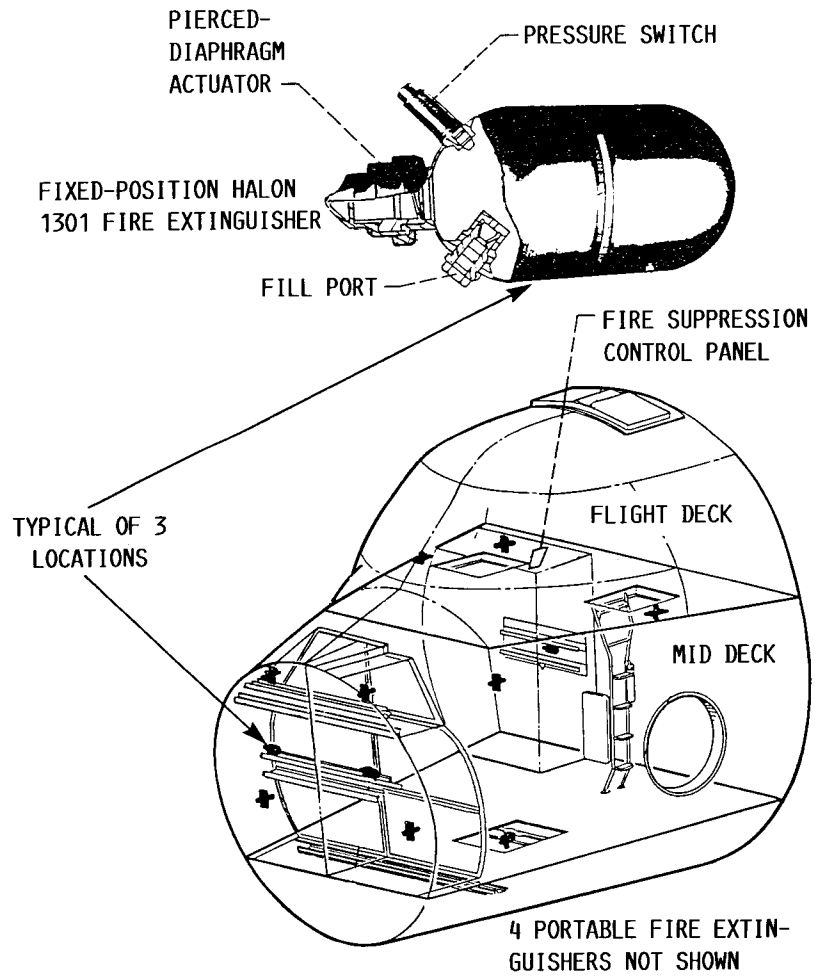

FIGURE 4. - HALON 1301 FIRE EXTINGUISHERS IN THE U.S SHUTTLE ORBITER CABIN.

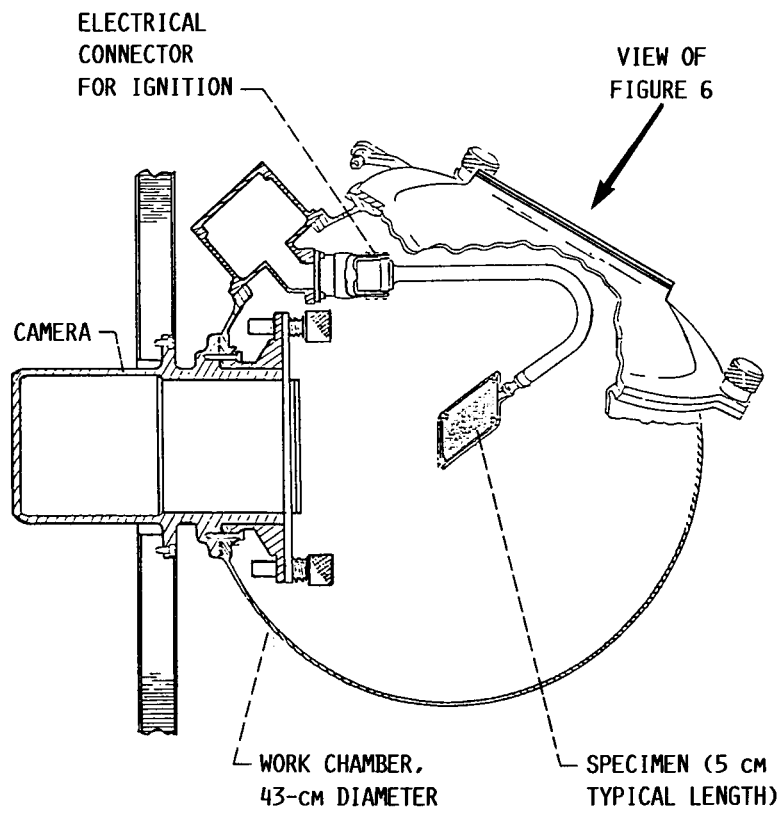

FIGURE 5. - LOW-GRAVITY FLAMMABILITY APPARATUS FLOWN IN THE 1974 SKYLAB MISSION.

ORIGINAL PAGE
BLACK AND WHITE PHOTOGRAPH

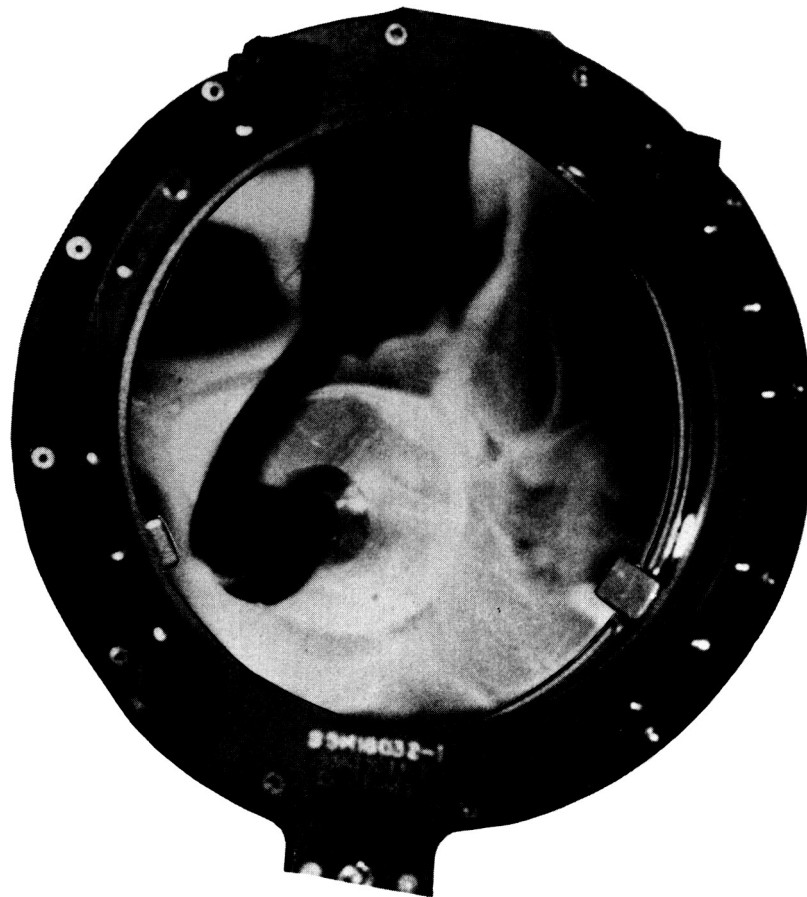
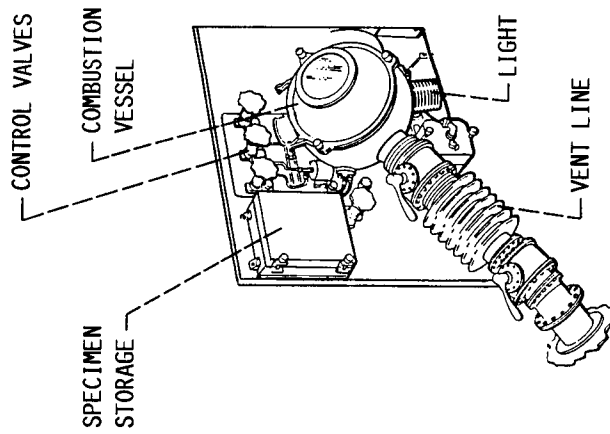
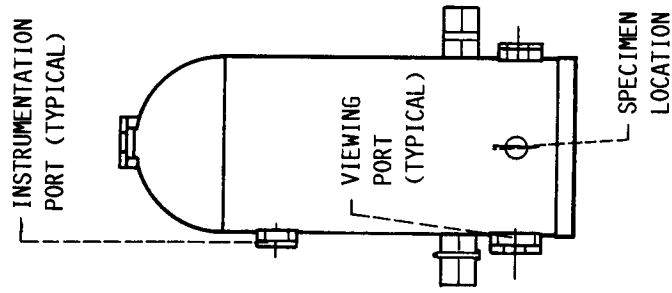

FIGURE 6. - SPHERICAL FLAME SURROUNDING POLYURETHANE FOAM SPECIMEN AT LOW GRAVITY, 65%-OXYGEN ATMOSPHERE, IN THE 1974 SKY-LAB EXPERIMENT.

AIRPLANE AND SKYLAB
(1965 TO 1974)



NASA LEWIS DROP TOWER
(PRESENT)



SOLID SURFACE COMBUSTION EXPERIMENT
(1990)

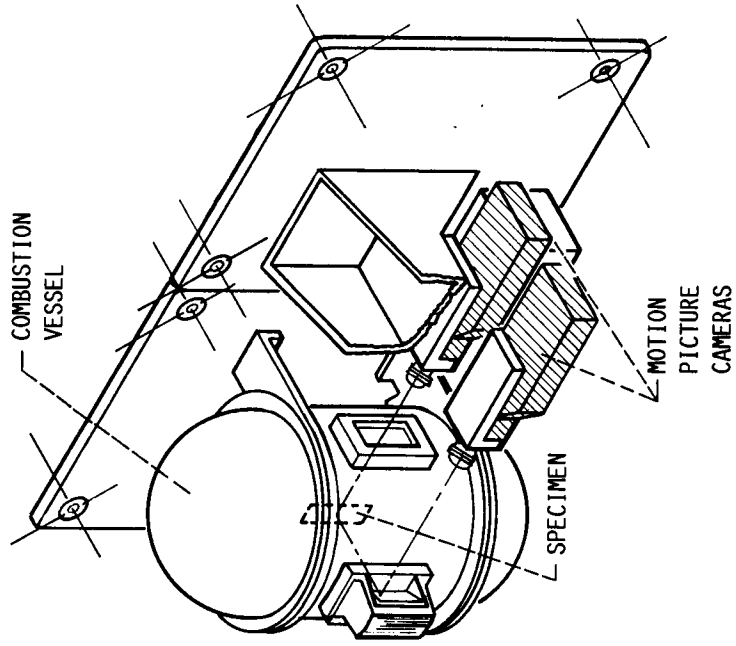

FIGURE 7. - REPRESENTATIVE LOW-GRAVITY, SOLID-SPECIMEN FLAMMABILITY TEST FACILITIES.

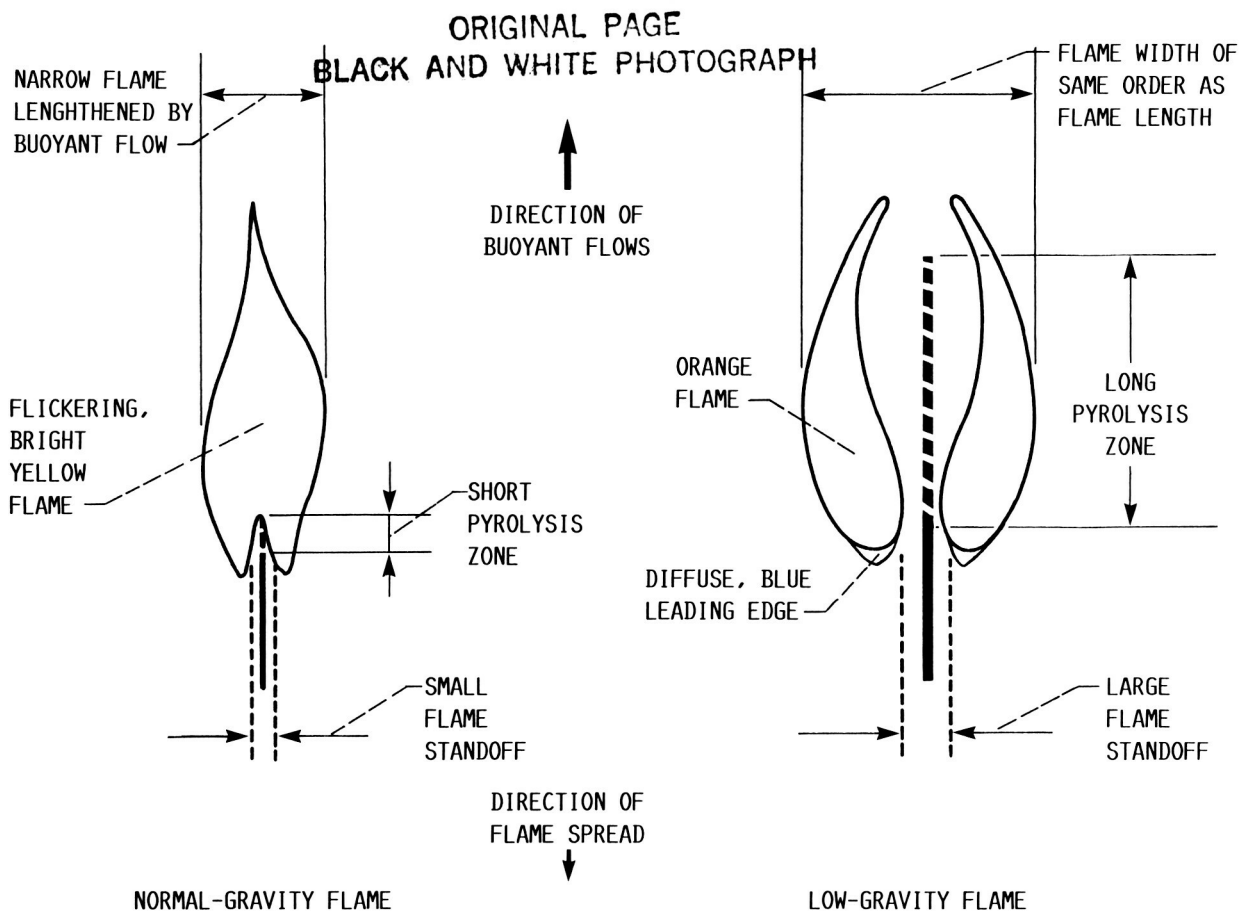

FIGURE 8. - COMPARISON OF TYPICAL NORMAL- AND LOW-GRAVITY FLAMES ON THIN SOLID SURFACES (PAPER, PLASTIC, E.G.).

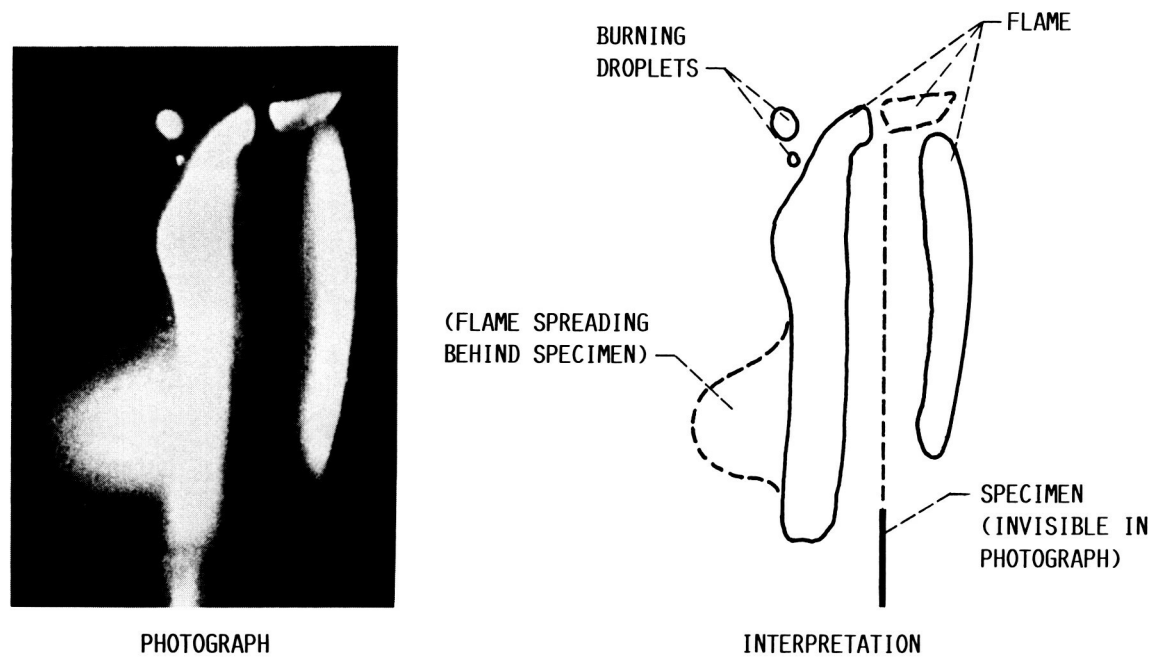

FIGURE 9. - EXPULSION OF BURNING DROPLETS FROM BURNING NYLON VELCRO SPECIMEN IN DROP-TOWER LOW-GRAVITY TEST.

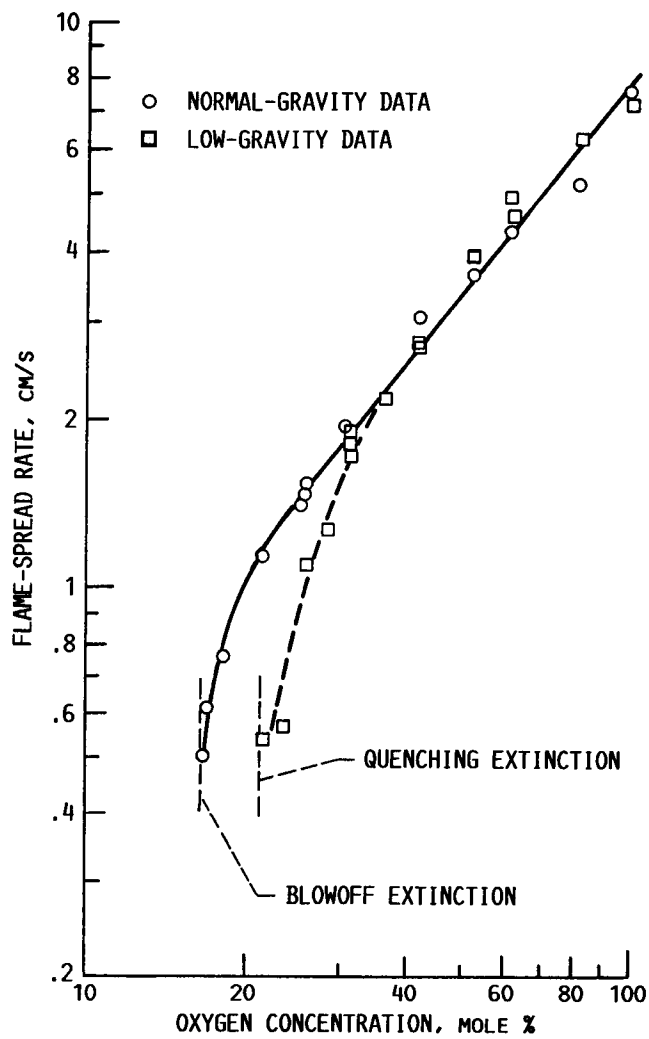

FIGURE 10. - COMPARISON OF FLAME-SPREAD RATES FOR NORMAL AND LOW-GRAVITY COMBUSTION OF THIN-PAPER SPECIMENS IN DROP-TOWER TESTS.

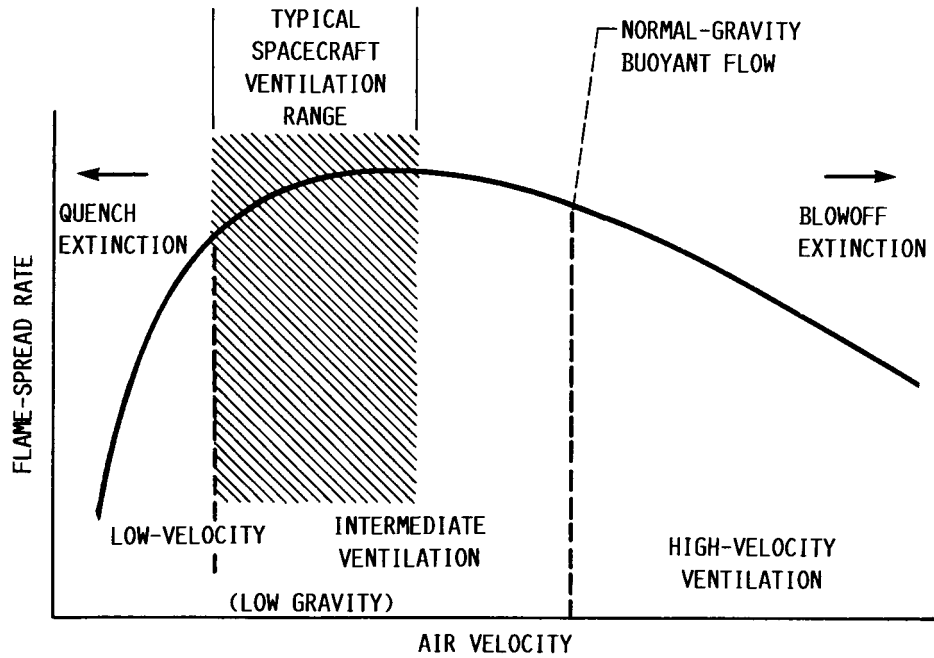

FIGURE 11. - EFFECT OF VENTILATION AIR FLOW ON FLAME-SPREAD RATE FOR THIN-PAPER SPECIMENS.

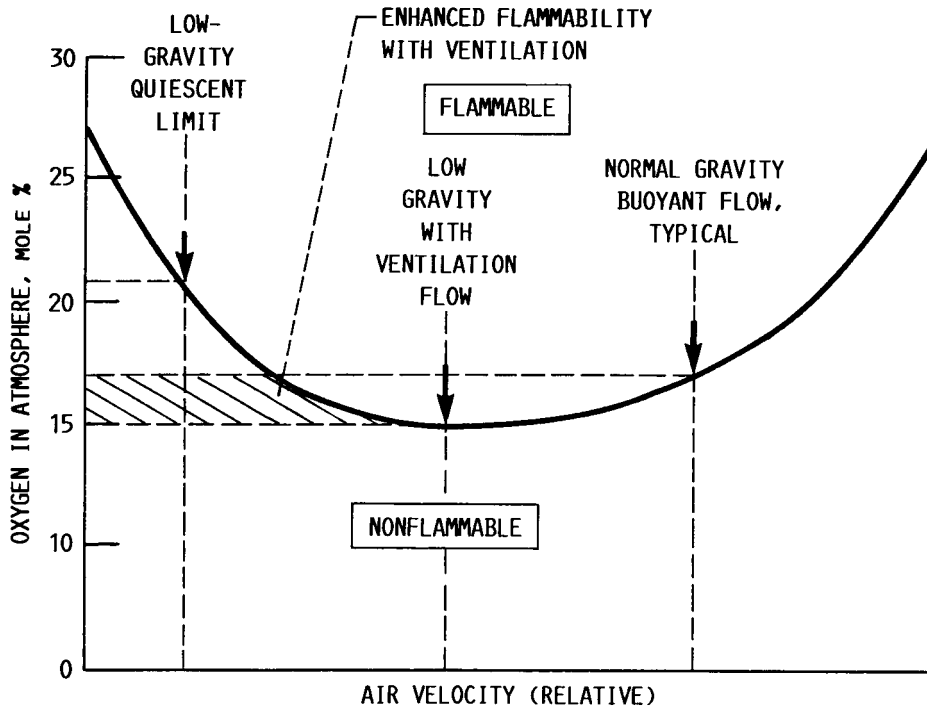

FIGURE 12. - FLAMMABILITY-LIMIT COMPARISON FROM DROP-TOWER LOW-GRAVITY DOWNWARD BURNING THIN-PAPER TESTS.

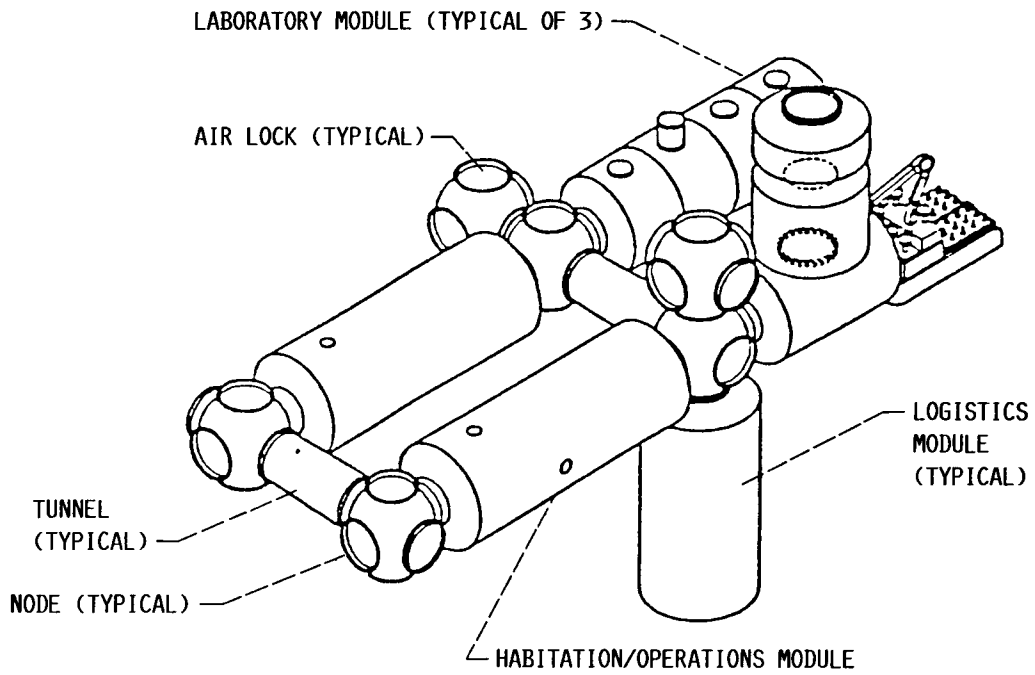

FIGURE 13. - PROPOSED "LADDER" CONFIGURATION OF U.S. SPACE STATION FREEDOM MODULES.

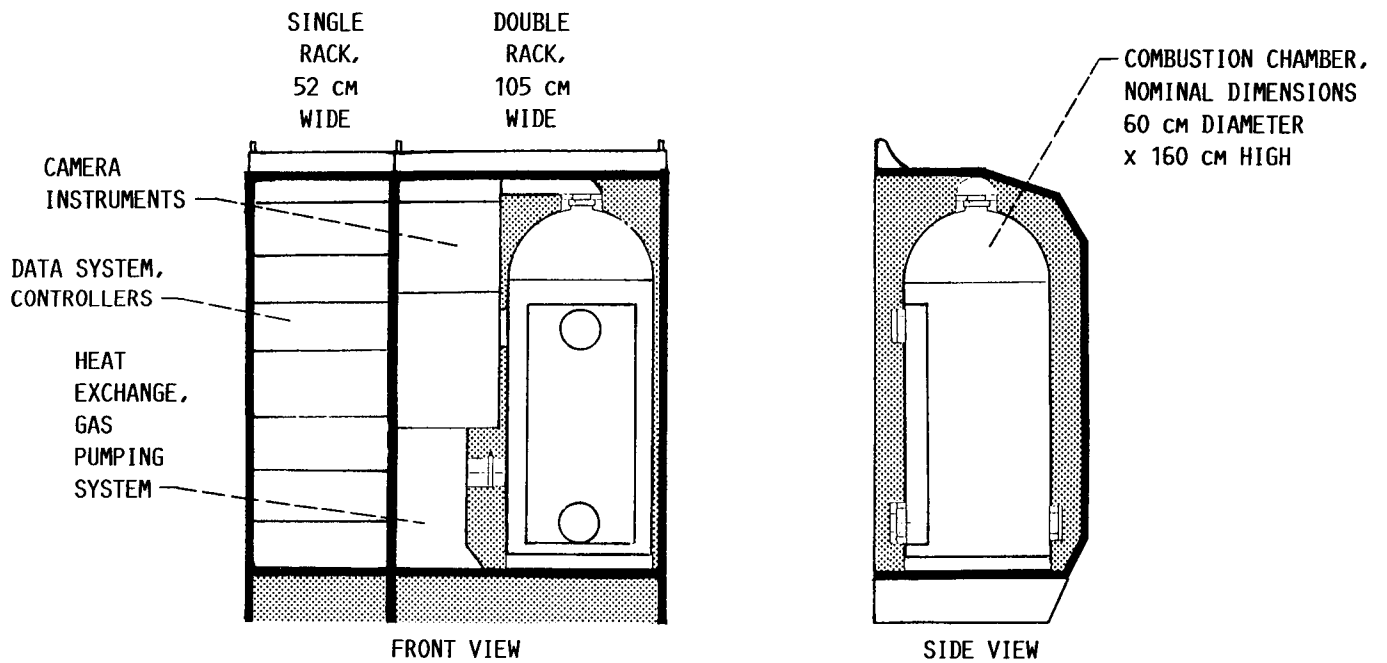

FIGURE 14. - PROPOSED MULTIEXPERIMENT COMBUSTION CHAMBER FOR FIRE-SAFETY EXPERIMENTS IN SPACE STATION FREEDOM EXPERIMENT RACKS.

1. Report No. NASA TM-101463		2. Government Accession No.		3. Recipient's Catalog No.	
4. Title and Subtitle Fire Safety Applications for Spacecraft				5. Report Date	
				6. Performing Organization Code	
7. Author(s) Robert Friedman and Sandra L. Olson				8. Performing Organization Report No. E-4511	
				10. Work Unit No. 323-53-62	
9. Performing Organization Name and Address National Aeronautics and Space Administration Lewis Research Center Cleveland, Ohio 44135-3191				11. Contract or Grant No.	
				13. Type of Report and Period Covered Technical Memorandum	
12. Sponsoring Agency Name and Address National Aeronautics and Space Administration Washington, D.C. 20546-0001				14. Sponsoring Agency Code	
15. Supplementary Notes Prepared for the Symposium on Aircraft Fire Safety sponsored by the AGARD/NATO Propulsion Energetics Panel, Sintra, Portugal, May 22-26, 1989.					
16. Abstract This paper reviews fire safety for spacecraft by first describing current practices, many of which are adapted directly from aircraft. The paper then discusses current analyses and experimental knowledge in low-gravity combustion, with implications for fire safety. In orbiting spacecraft, the detection and suppression of flames are strongly affected by the large reduction in buoyant flows under low gravity. Generally, combustion intensity is reduced in low gravity. There are some notable exceptions, however, one example being the strong enhancement of flames by low-velocity ventilation flows in space. Finally, the paper examines the future requirements in fire safety, particularly the needs of long-duration space stations in fire prevention, detection, extinguishment, and atmospheric control. The goal of spacecraft fire-safety investigations is the establishment of trade-offs that promote maximum safety without hampering the useful human and scientific activities in space.					
17. Key Words (Suggested by Author(s)) Fire safety; Fire detection; Fire extinguishers; Spacecraft fire safety; Microgravity combustion; Space Station Freedom			18. Distribution Statement Unclassified - Unlimited Subject Category 16		
19. Security Classif. (of this report) Unclassified		20. Security Classif. (of this page) Unclassified		21. No of pages 28	22. Price* A03