

N 8 9 - 2 4 6 4 1

NONLINEAR RESPONSE OF A BLADE-STIFFENED GRAPHITE-EPOXY PANEL
WITH A DISCONTINUOUS STIFFENER: WORK IN PROGRESS

Norman F. Knight, Jr., William H. Greene,
and W. Jefferson Stroud
NASA Langley Research Center
Hampton, Virginia

INTRODUCTION

Discontinuities and eccentricities are usually present in practical structures. In addition, potential damage of otherwise perfect structures is often an important design consideration. Predicting the structural response in the presence of discontinuities, eccentricities, and damage is particularly difficult when the component is built from graphite-epoxy materials or is loaded into the nonlinear range. Recent interest in applying graphite-epoxy materials to aircraft primary structures has led to several studies of postbuckling behavior and failure characteristics of graphite-epoxy structural components (e.g., refs. 1-3). However, these studies concentrated on two topics: prediction of the overall response of composite structural components in the postbuckling range or failure mechanisms and analytical failure prediction techniques for fibrous composite materials. The problem of calculating detailed stress distributions around discontinuities in buckled, composite structural components for use with the various analytical failure prediction techniques has not been thoroughly explored.

The purpose of this paper is the application of computational methods to the detailed stress analysis problem which is the focus of this session of the workshop. One approach to uncovering the difficulties of this type of analysis and to providing specific directions for future research in this area is a direct attack on the problem using currently available analysis tools. A candidate problem has been selected and the remainder of the paper describes experiences from calculating its structural response.

PRECEDING PAGE BLANK NOT FILMED

BLADE-STIFFENED GRAPHITE-EPOXY PANEL WITH A DISCONTINUOUS STIFFENER:
FOCUS PROBLEM

The focus problem for the local/global stress analysis session of this workshop is to determine the nonlinear response of a flat blade-stiffened graphite-epoxy panel with a discontinuous stiffener. The material system for the panel is T300/5208 graphite-epoxy with a nominal ply thickness of 0.0055 in. Typical lamina properties for this graphite-epoxy system are 19,000 ksi for the longitudinal Young's modulus, 1,890 ksi for the transverse Young's modulus, 930 ksi for the shear modulus, and 0.38 for the major Poisson's ratio. The panel skin has 25 plies $([+45/0_2/\bar{+45}/0_3/\pm 45/0_3/\bar{+45}/0_3/\pm 45/0_2/\bar{+45}])$ and the blade stiffeners have 24 plies $([+45/0_2/\bar{+45}])$. The overall length of the panel is 30 in., the overall width is 11.5 in., stiffener spacing is 4.5 in., stiffener height is 1.4 in., and the hole diameter is 2 in. The loading is uniform axial compression. The loaded ends of the panel are clamped and the sides are free.

This problem was selected as the focus problem because experimental results are available and because it has characteristics which often require a local/global analysis. These characteristics include a discontinuity, eccentric loading, large displacements, large stress gradients, high inplane loading, and a brittle material system. This problem represents a generic class of laminated composite structures with discontinuities in which the interlaminar stress state becomes important.

- Graphite-epoxy (T300/5208)
- Flat panel with three blade stiffeners
- 30 in. long
- 11.5 in. wide
- Stiffener spacing of 4.5 in.
- Stiffener height of 1.4 in.
- 2.0-in.-diameter hole
- 25-ply panel skin
- 24-ply blade stiffeners
- Axially loaded with loaded ends clamped and sides free



ORIGINAL PAGE
BLACK AND WHITE PHOTOGRAPH

LOCAL/GLOBAL TERMINOLOGY

The definition of a local/global structural analysis is not precise. For example, several levels of detail are considered in the analysis of an aircraft structure, and the concepts of local and global can change with every change in analysis level. To some, the entire aircraft is the global model, and a fuselage section is the local model. To others, lamination theory represents the global model, and micromechanics is used for the local model. For this workshop, a local/global analysis is a local, detailed stress analysis within a larger, less-refined global analysis model. The overall response of the panel is the global problem; the response near the hole is the local problem.

Current areas of research associated with local/global methodologies are described in the literature (e.g., refs. 4 and 5). One research area (discretization procedures) includes finite-element methods, finite-difference methods, and boundary element or boundary integral methods. Adaptive mesh refinement, h- and p-convergence, and error analysis are current research topics in this area which address discretization effects in the presence of a large stress gradient. A second area (refined theories) includes research in transverse shear formulations and three-dimensional elasticity solutions. These topics focus on the mathematical representation of the mechanics of the problem. A third area includes classical and closed-form solutions which are often restricted to simple geometries, specific boundary conditions and material systems, and often to a linear response prediction. A fourth area is hybrid techniques in which two or more methods are used simultaneously but in different domains of the structure. All four of these areas of research are addressed in the local/global session of this workshop.

- **Concept of local/global changes with analysis level**

- **Definitions**

- Global means overall panel response
- Local means response near the hole

- **Local/global methodologies**

- Discretization procedures
- Refined theories
- Classical and closed-form solutions
- Hybrid techniques

APPLICATION OF THE FINITE-ELEMENT METHOD
TO LOCAL/GLOBAL STRESS ANALYSIS

The local/global methodology adopted for this paper is the finite-element method because of its generality. The first step in applying the method was to develop and verify a finite-element model of the focus problem. Model verification involved solving simpler example cases and comparing the results with other analytical results. This model verification process was aided by the development of a flexible mesh generation capability which allowed various finite-element discretizations to be evaluated rapidly and systematically. The mesh generation capability also provided an easy way to construct and study several idealized example cases.

Once an adequate finite-element model for the global response was verified, the nonlinear structural response was calculated. To identify the local modeling detail required to predict accurately the stress distribution near the hole, linear stress analyses were performed on a rectangular plate with a circular hole using several refined 2-D models near the hole.

- Finite-element model development

- Finite-element model verification

- Global nonlinear response prediction

- Local linear stress analysis

FINITE-ELEMENT MODEL DEVELOPMENT

The model development strategy is to predict the global nonlinear response using the complete model and then to construct a refined, local 2-D model for a small distance away from the hole to predict accurately the large stress gradient. Displacements and rotations from the global nonlinear solution obtained using the complete model will be applied to the refined model and the state of stress will be determined. This strategy will be referred to as a multi-level or "zoom-in" approach.

The automated mesh generation capability allowed versatile modeling of the complete problem as well as local regions near the hole. The analyst could specify the number of elements across the stiffener depth and down the length of the panel, the number of rings of elements around the hole, and the number of elements around the hole, and could control the element spacing in the vicinity of the hole. Models could also be generated with the hole and discontinuous stiffener filled-in or with no stiffeners.

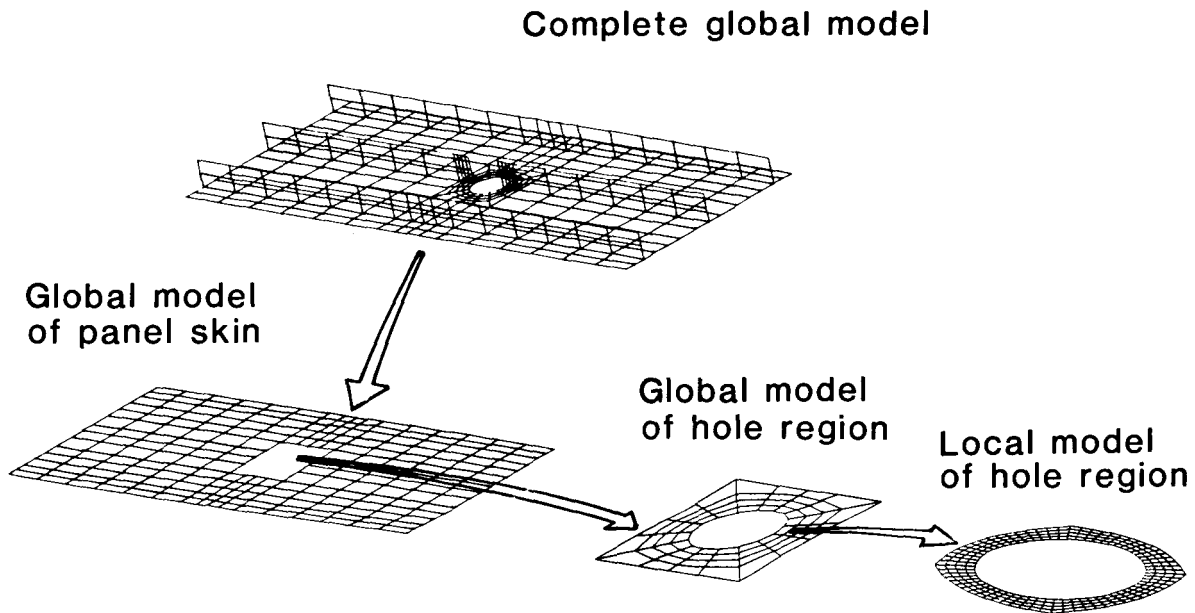

FINITE-ELEMENT MODEL VERIFICATION:
BLADE STIFFENED PANEL

In the first step of the verification process, a simplified version of the focus problem was studied. This simpler problem was identical to the focus problem except that the hole and discontinuous stiffener are filled-in and the end boundary conditions are now simple support conditions. For this prismatic panel, an exact solution was obtained using the PASCO computer code (Panel Analysis and Sizing COde, ref. 6). The finite-element analysis system EAL (Engineering Analysis Language, ref. 7) was used for the finite-element analysis. The finite-element model used in the verification was developed from that of the focus problem to determine if any problems related to element distortion or aspect ratio were present. The prebuckling boundary conditions and end loading are such that a uniform stress state is present in the skin and the blade stiffeners. The three lowest buckling eigenvalues obtained using EAL are very close to the PASCO solutions.

Buckling mode

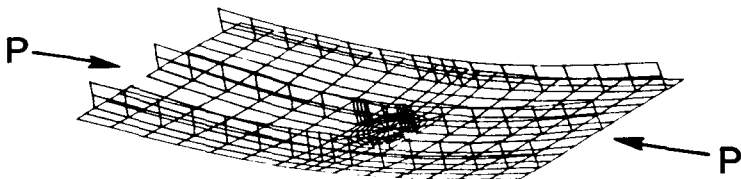

	Eigenvalues		
	1	2	3
PASCO	44536	51063	61601
EAL	44652	51182	60975
Difference	+0.26%	+0.23%	-1.02%

FINITE-ELEMENT MODEL VERIFICATION:
FOCUS PROBLEM

The next step of the verification process was to define an adequate finite-element model for the global response of the focus problem. Finite-element model verification for the focus problem started with a "reasonable grid" of 376 4-node assumed-stress quadrilateral elements and 422 nodes. This discretization is referred to as Mesh 1. A second, refined grid of 1088 4-node quadrilateral elements and 1168 nodes (Mesh 2) was generated for model verification. Linear bifurcation buckling solutions for Mesh 1 and Mesh 2 were compared to establish the adequacy of the models. The three lowest eigenvalues from both discretizations agree within approximately one percent.

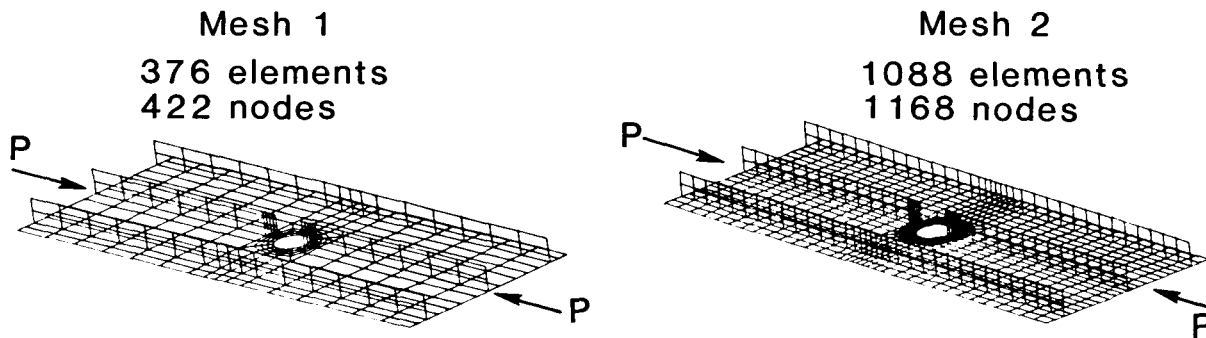

	Eigenvalues			
	1	2	3	4
Mesh 1	41378	52754	54288	55344
Mesh 2	41829	52533	54259	56895
Change	-1.08%	+0.42%	+0.05%	-2.73%

LINEAR BIFURCATION BUCKLING SOLUTION

Oblique views of the prebuckling deformation pattern and the eigenmodes corresponding to the four lowest eigenvalues are shown in this figure. The discontinuous stiffener leads to an eccentric loading condition which causes large out-of-plane displacements to develop near the hole from the onset of loading. Because of this coupling between inplane and out-of-plane displacements, no linear equilibrium path exists and the linear bifurcation buckling results do not have the traditional meaning. The linear buckling solutions may be used as a guide in selecting the initial load for the nonlinear analysis and in choosing a load step size. However, their main use is in studying the effects of spatial discretization.

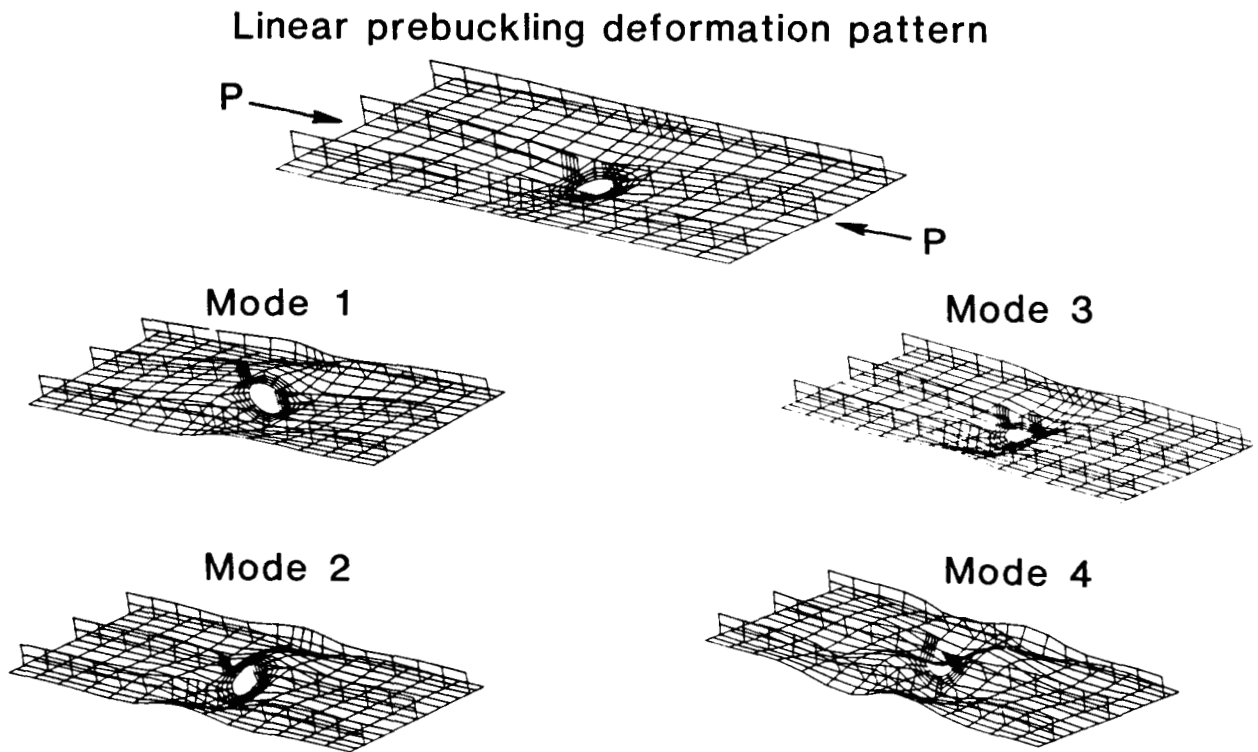

GLOBAL NONLINEAR RESPONSE PREDICTION

The global nonlinear response predicted for the focus problem was obtained using a new release of EAL. This new release has a nonlinear analysis capability using a corotational formulation with linear strain-displacement relations within the elements. For this problem, the loading was applied in increments with a full Newton-Raphson algorithm. Convergence was based on the maximum error in the residual force vector.

An oblique view of the deformed geometry for the last calculated solution is similar to the linear solution shown previously, indicating that the primary equilibrium path is being followed. A global response quantity, end shortening, is nearly a linear function of the applied load. A local response quantity, out-of-plane displacement at the edge of the hole and blade stiffener, indicates large displacements from the onset of loading. Longitudinal inplane stress-resultant distributions for two values of the applied load, as a function of distance from the hole, indicate high inplane stresses and a high stress gradient near the hole.

These high inplane stresses and stress gradients coupled with the large out-of-plane displacements and the free edge of the hole may cause material nonlinearities, local failures, and/or delaminations to develop in order to provide local stress relief mechanisms (like plasticity in metal structures) near the hole and blade stiffener. However, an accurate prediction of the effects of these mechanisms on the global nonlinear response is beyond the current analysis capabilities. Stress fracture criteria are developed in reference 8 for an inplane loading condition in which the influence of these stress relief mechanisms can be accounted for in failure studies without knowing exactly what is happening locally near the hole. The point stress failure criterion developed in reference 8 and applied in reference 9 to a broad class of laminated composite plates with holes will be used in this study as a guide for establishing an adequate finite-element model for predicting the stress distributions near the hole.

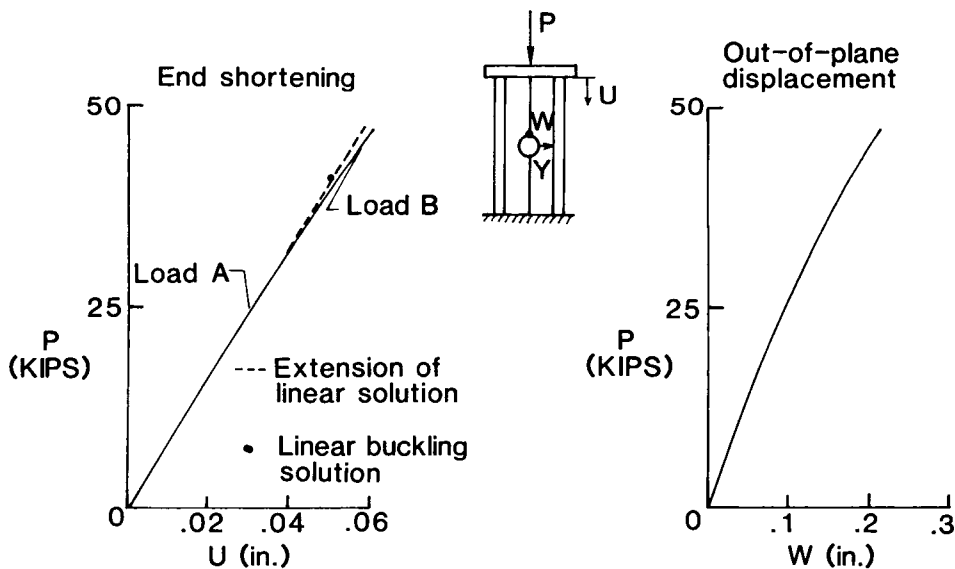

GLOBAL NONLINEAR RESPONSE PREDICTION

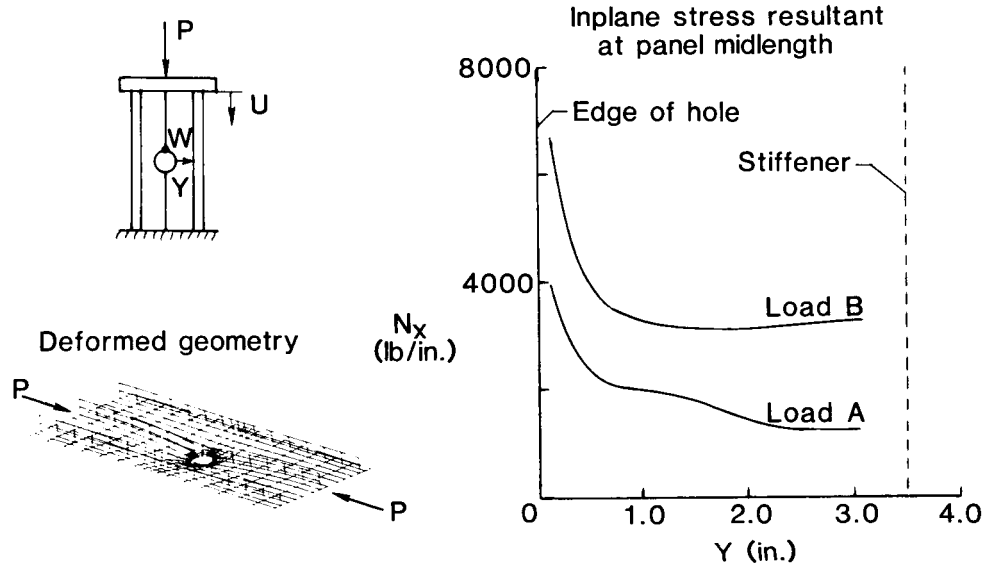

POINT STRESS FAILURE CRITERION

The point stress failure criterion assumes that failure occurs when the stress at a distance d_0 away from the edge of the hole reaches ultimate. The distance d_0 is a characteristic dimension which takes the form of a material property. A consequence of using this criterion is that an accurate prediction of the state of stress precisely at the free edge of the hole is not required. It is only necessary to have an accurate stress prediction at a distance d_0 from the edge of the hole. Based on results of reference 9 with a similar graphite-epoxy material system, a value of $d_0 = 0.05$ inches was assumed. Model A corresponds to the global model near the hole for Mesh 1. Model B is a refined model which more accurately predicts the stress gradient near the hole.

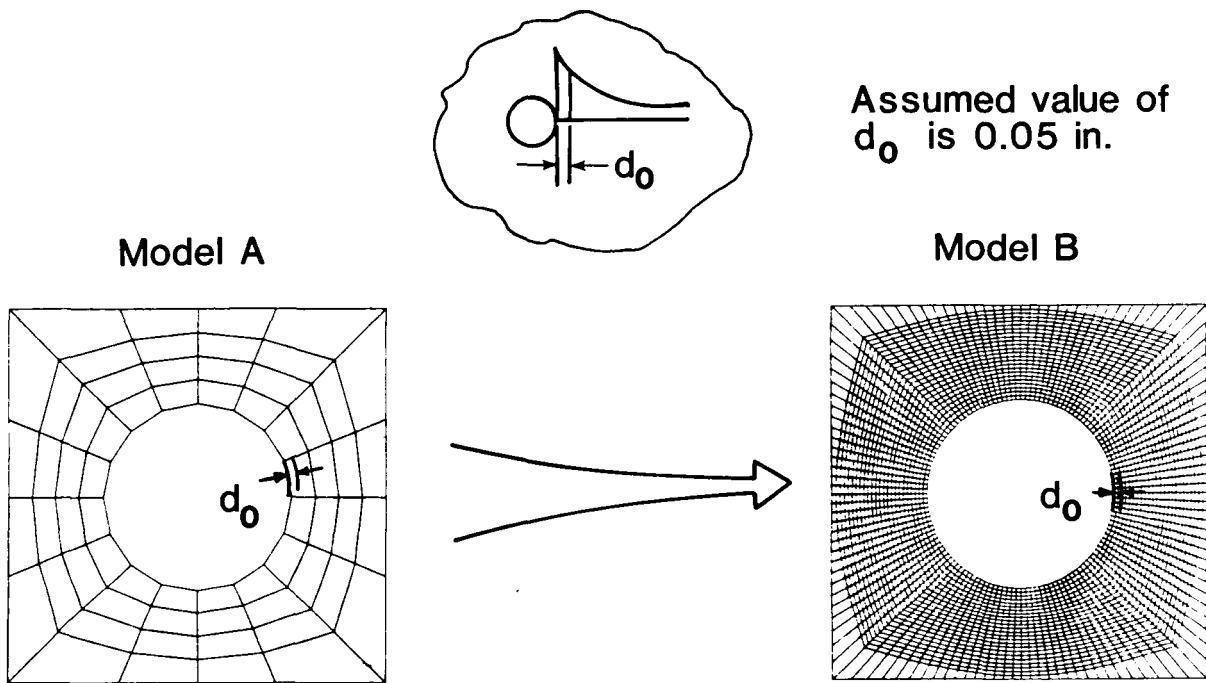

LOCAL LINEAR STRESS ANALYSIS

To understand how the spatial discretization near the hole affects the prediction of the stress at d_0 , a simpler structural configuration was considered which did not include the stiffeners. Using this planar structure, an adequate 2-D finite-element model was identified for the local stress analysis. This approach provided the necessary insight required for a multi-level model of the focus problem. An alternate approach would have been to use an adaptive mesh refinement procedure. However, no such procedure was available. The longitudinal inplane stress resultant distributions as a function of distance away from the edge of the hole are shown for two finite-element models. The results from both models approach one another away from the hole. However, at a distance d_0 from the edge of the hole, the solutions for Models A and B differ by 12.5 percent. The finite-element model in the vicinity of the hole was refined by doubling the number of elements. The inplane stress resultant at d_0 changed by only 2.2 percent between Model B and a model with half as many elements.

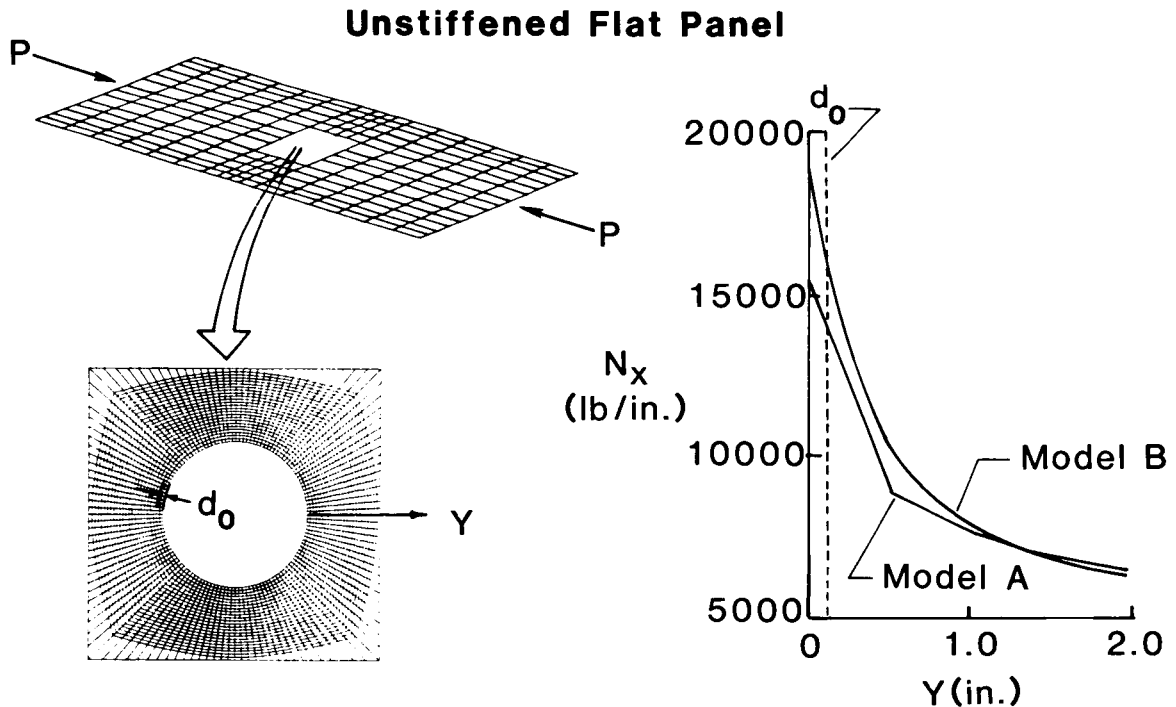

STATUS AND ADDITIONAL TASKS

The overall strategy for this study is to predict the global nonlinear response using the complete global model and then to construct a refined, local 2-D model for a small distance away from the hole. The global nonlinear response has been predicted for the focus problem and the local modeling detail required for an accurate local stress analysis near the hole of an unstiffened panel has been identified. The tasks that remain to be completed for the focus problem include performing the multi-level analysis and applying a failure criterion. The multi-level analysis will involve applying the displacements and rotations from the global nonlinear solution on the refined local 2-D model and determining the state of stress at d_0 . In addition, a three-dimensional model near the discontinuity will be required for an accurate determination of the through-the-thickness state of stress (i.e., normal and transverse shearing stress distributions). The use of 3-D elements within a 2-D model will also require a strategy for the transition or blending of the two models.

Status

- Finite element model developed and verified
- Global nonlinear response predicted
- Required modeling detail identified for stress gradient near the hole for an unstiffened panel

Additional tasks for focus problem

- Perform multi-level 2-D analysis (refined, local 2-D model)
- Apply point stress failure criterion
- Perform multi-level 3-D analysis (refined, local 3-D model)

SUMMARY

The local/global nonlinear stress analysis of a blade-stiffened graphite-epoxy panel with a discontinuous stiffener is indeed a computational challenge. Substantial engineering effort is required in modeling the structure, in verifying that the physics of the problem are modeled, and in interpreting the predicted nonlinear solutions. Approximately fifty percent of the analysis effort to date was devoted to model development and verification. The development of a flexible mesh generation capability was essential for model verification. Several models of similar but simpler structures were required and easily generated using the automated mesh generator.

To complete the analysis effort for the focus problem several issues need to be addressed. The transition or interface between the various levels of the multi-level model needs to be defined. An adaptive mesh refinement procedure is needed to automate the definition of the finite-element models at each stage of the multi-level approach. To obtain a detailed through-the-thickness stress distribution, a three-dimensional analysis will be required and the number of three-D elements through-the-thickness of the laminate needs to be determined. In addition, to predict the response of the structure up to overall structural failure, a progressive failure analysis capability would be required in which various failure mechanism and failure criteria are incorporated.

- Substantial engineering effort required in modeling, model verification, and response interpretation.
- Flexible mesh generation capability essential to model verification.
- Definition of transition/interface region between multi-level models required.
- Required number of 3-D elements through-the-thickness to be determined.
- Nonlinear analysis procedure with progressive failure analysis capability needed.

REFERENCES

1. Starnes, James H., Jr., Dickson, John N. and Rouse, Marshall, "Postbuckling of Graphite-Epoxy Panels," ACEE Composite Structures Technology: Review of Selected NASA Research on Composite Materials and Structures, NASA CP-2321, 1984, pp. 137-160.
2. Starnes, James H., Jr. and Williams, Jerry G., "Failure Characteristics of Graphite-Epoxy Structural Components Loaded in Compression," NASA TM-84552, September 1982. Also, in Mechanics of Composite Materials; Recent Advances, Proceedings of the IUTAM Symposium on Mechanics of Composite Materials, Z. Hashin and C. T. Herakovich (editors), Pergamon Press, Inc., 1983, pp. 283-306.
3. Noor, A. K., Shuart, M. J., Starnes, J. H., Jr., and Williams, J. G. (Compilers), Failure Analysis and Mechanisms of Failure of Fibrous Composite Structures, NASA CP-2278, 1983.
4. Zienkiewicz, O. C., "The Generalized Finite Element Method---State of the Art and Future Directions," Journal of Applied Mechanics, ASME, Vol. 50, December 1983, pp. 1210-1217.
5. Noor, A. K. and Pilkey, W. D. (editors), State-of-the-Art Surveys on Finite Element Technology, ASME, New York, 1983.
6. Anderson, Melvin S. and Stroud, W. Jefferson, "A General Panel Sizing Computer Code and Its Application to Composite Structural Panels," AIAA Journal, Vol. 17, No. 8, August 1979, pp. 892-897.
7. Whetstone, W. D., EISI-EAL Engineering Analysis Language Reference Manual - EISI-EAL System Level 2091, Engineering Information Systems, Inc., San Jose, CA, July 1983.
8. Whitney, J. M. and Nuismer, R. J., "Stress Fracture Criteria for Laminated Composites Containing Stress Concentrations," Journal of Composite Materials, Vol. 8, July 1974, pp. 253-265.
9. Mikulas, Martin M., Jr., "Failure Prediction Techniques for Compression Loaded Composite Laminates with Holes," Selected NASA Research in Composite Materials and Structures, NASA CP-2142, 1980, pp. 1-34.