

N 8 9 - 2 4 6 4 9**FEATURES AND CHARACTERIZATION NEEDS OF
RUBBER COMPOSITE STRUCTURES**

Farhad Tabaddor
Goodrich Company
Akron, Ohio

Abstract

This paper outlines some of the major unique features of rubber composite structures. The features covered are those related to the material properties, but the analytical features are also briefly discussed. It is essential to recognize these features at the planning stage of any long-range analytical, experimental, or application program.

The development of a general and comprehensive program which fully accounts for all the important characteristics of tires, under all the relevant modes of operation, may present a prohibitively expensive and impractical task at the near future. There is therefore a need to develop application methodologies which can utilize the less general models, beyond their theoretical limitations and yet with reasonable reliability, by proper mix of analytical, experimental, and testing activities.

OUTLINE:

1. CORDS
2. RUBBER
3. RUBBER COMPOSITES

Single Ply
Laminate

4. ANALYTICAL AND
COMPUTATIONAL ASPECTS

PRECEDING PAGE BLANK NOT FILMED

INTRODUCTION

The textile-cord-reinforced-rubber composites used in various industrial products differ in many respects from the classical rigid composites. There are a great number of papers, books, and professional journals devoted to rigid composites. The literature on rubber composites, however, is very limited as compared to classical composites. To understand the mechanics of such composites, it is essential to develop an in-depth understanding of the way in which the internal variables of the constituents participate and interact in responding to external agents, i.e., mechanical, thermal or other environmental forces. It is, however, important to first study the properties of each constituent before dealing with the material properties of rubber composites.

CORDS

The textile cord reinforcements are structural members which may be viewed as one dimensional in a microscopic sense. The cords generally consist of several yarns twisted together. The yarns also consist of numerous filament components organized in a geometrical array with the view towards enhancing certain target properties. The cord properties therefore depend on the properties of the filaments and the geometrical organization as well as the interfacial characteristics. The filament itself has also been known to possess an internal structure at the microscopic level.

In view of the above consideration, the cord itself is a complex structure which may be studied at the microscopic level (figs. 1 and 2). The way in which the cord properties are related to filament properties, geometries (ref. 1) and other variables is the subject of textile mechanics (fig. 3). Properties such as strength, stiffness, and fatigue characteristics can be controlled by internal variables when their relationships are well understood.

From a higher scale of continuum mechanics we are, however, concerned only with the phenomenological properties of the cords as experimentally obtained without any attempt for relating such

measured values to the micro-structure in the sense of textile mechanics. The properties of interest at this continuum level are therefore the effective cord properties.

Such an approach enables us to bypass the complexity of the textile mechanics in our formulation of composite properties. The limitation is, however, that such measured properties serve as "averages" only and therefore the continuum elements should be at least in the order of cord diameters.

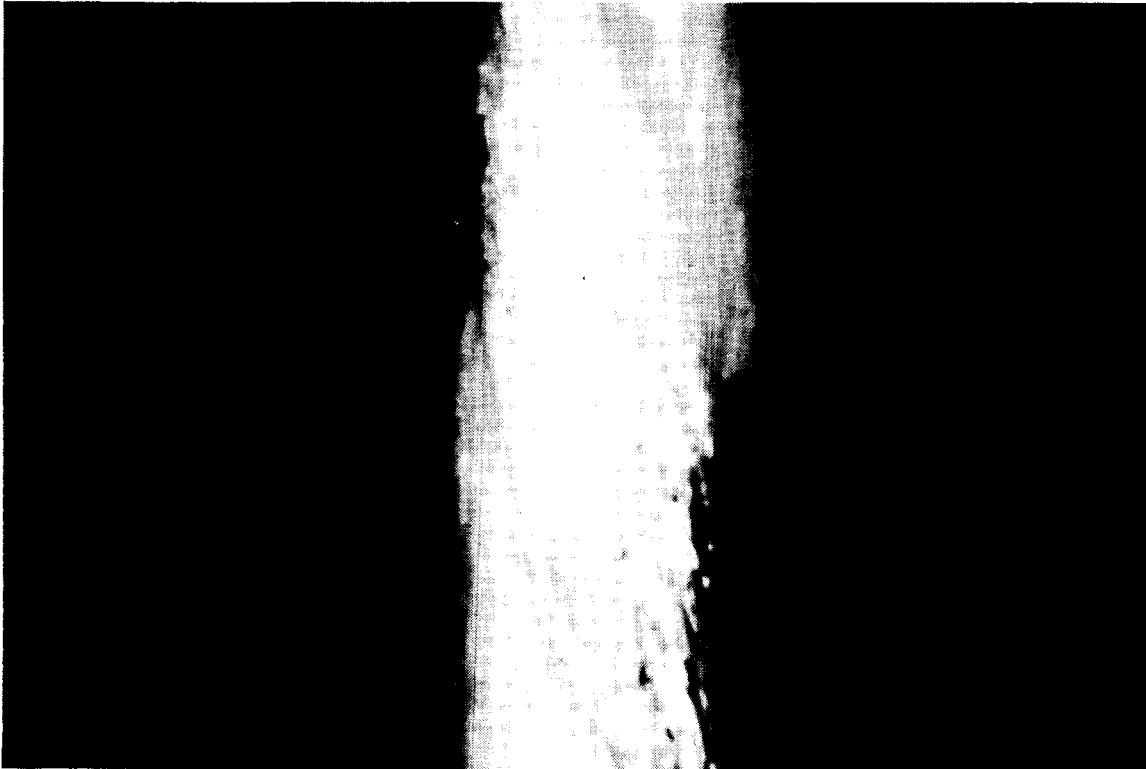
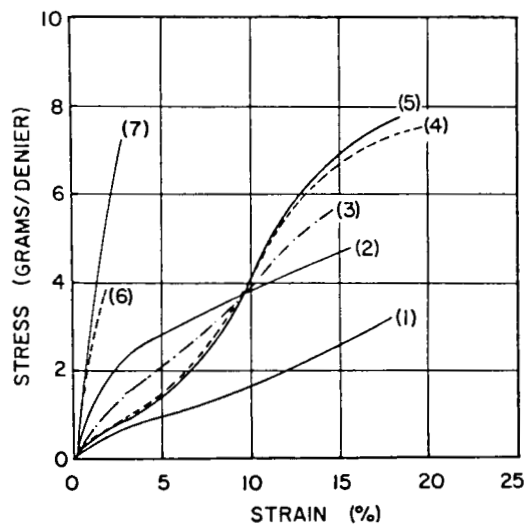

Figure 1. Typical tire cord.

ORIGINAL PAGE
BLACK AND WHITE PHOTOGRAPH



Figure 2. Cross section of tire cord (2).



- | | |
|---------------|--------------|
| (1) RAYON | (5) NYLON-66 |
| (2) NOMEX | (6) STEEL |
| (3) POLYESTER | (7) GLASS |
| (4) NYLON-6 | |

TESTED AT 70°F, 65% R.H.
INSTRON - 100% STRAIN RATE

Figure 3. Stress-strain characteristics of typical tire cords (2).

The cord is the major load-bearing member of rubber composite structures and as such should provide strength and many other characteristics of interest. Some of the expected performance characteristics of the tire, and for that matter any other structure, can be directly related to cord properties. Let us consider some of the tire performance characteristics which are affected by cord properties. A partial list is given in Table 1.

Table 1

TIRE PERFORMANCE AFFECTED BY CORDS

- o Burst Strength
- o Bruise Resistance
- o Tire Endurance (Separations)
- o Power Loss
- o Tread Wear
- o High-Speed Endurance
- o Tire Size and Shape
- o Groove Cracking
- o Flat Spotting and Non-Uniformity
- o Tire Cornering Force
- o Tire Spring Rate
- o Noise

Tables 2 to 4 of reference (3) provide a list of tire requirements and the related cord requirements. Such relations should be viewed with caution and qualifications.

Table 2

(REF. 3)

RADIAL PASSENGER

Vehicle Trends	Tire Requirements	Cord Requirements
High Performance	Low Aspect Ratio (Increased Cornering Forces)	Modulus Lateral Stiffness
Downsizing	Downsizing - Monoply	Dimensional Stability Fatigue Modulus Tenacity
Front Wheel Drive	Improved Tread Wear Retreading	Dimensional Stability Lateral Stiffness Aged Adhesion Thermal Stability Fatigue
Fuel Economy	Rolling Resistance	Tenacity Modulus Hysteresis

Table 3

(REF. 3)

RADIAL TRUCK

Vehicle Trends	Tire Requirements	Cord Requirements
Increased Drive Position Loads	Increased Durability	Tenacity Strength/Area Ratio
Improved Fuel Economy/New Transportation Act	Lighter Weight Low Profile Retreading	Tenacity Fatigue Aged Adhesion Fatigue Thermal Stability
	Rolling Resistance	Tenacity Modulus Hysteresis

Table 4

(REF. 3)

RADIAL AIRCRAFT

Tire Requirements	Cord Requirements
High Deflection	Tenacity Modulus Thermal Stability
Reduced Weight	Tenacity Strength/Area Ratio
Retread	Aged Adhesion Dimensional/Thermal Stability Fatigue

CORD VISCOELASTICITY

The textile cords used in rubber-reinforced composites are often nonlinear viscoelastic. The viscoelastic deformations are associated with the loss of energy. The dissipated energy appears as heat and leads to temperature rise which in turn affects the material properties. The cord is therefore an important contributor to the energy loss in rubber-composite structures such as tires (4). Figures 4 and 5 show some of the viscoelastic properties of polyester cords.

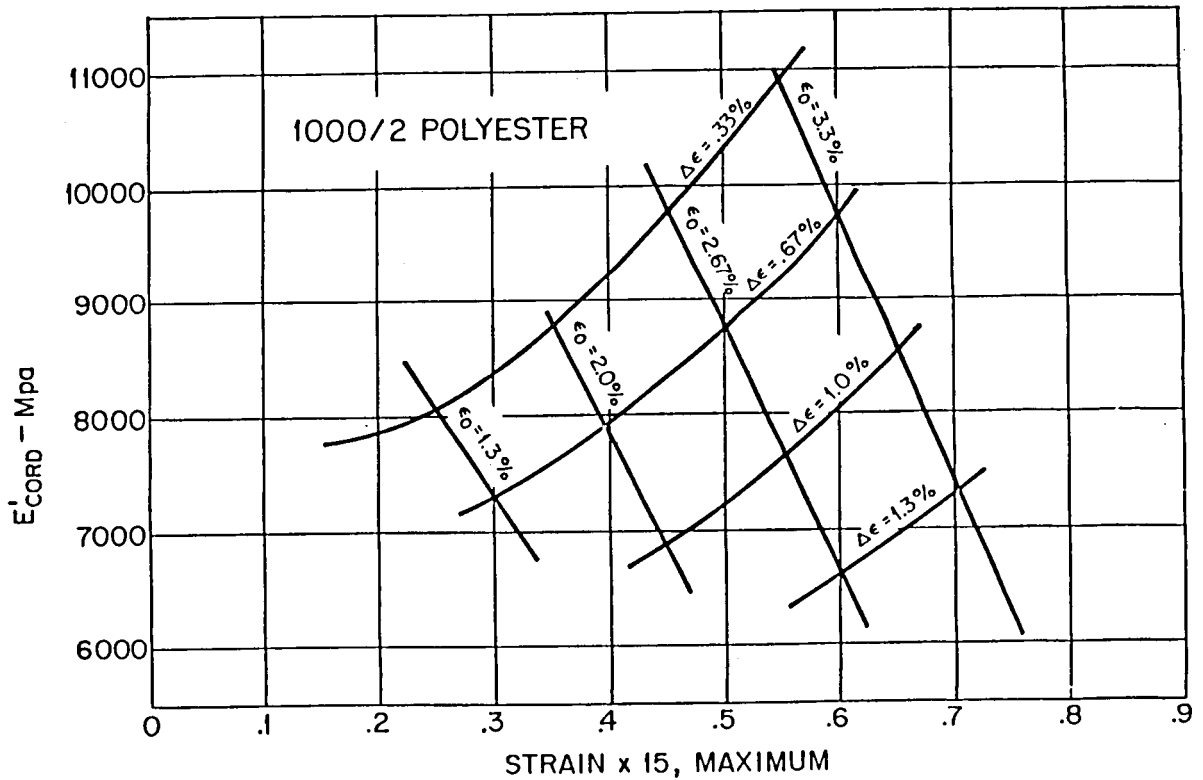

Figure 4. Carpet plot of 1000/2 polyester real modulus.

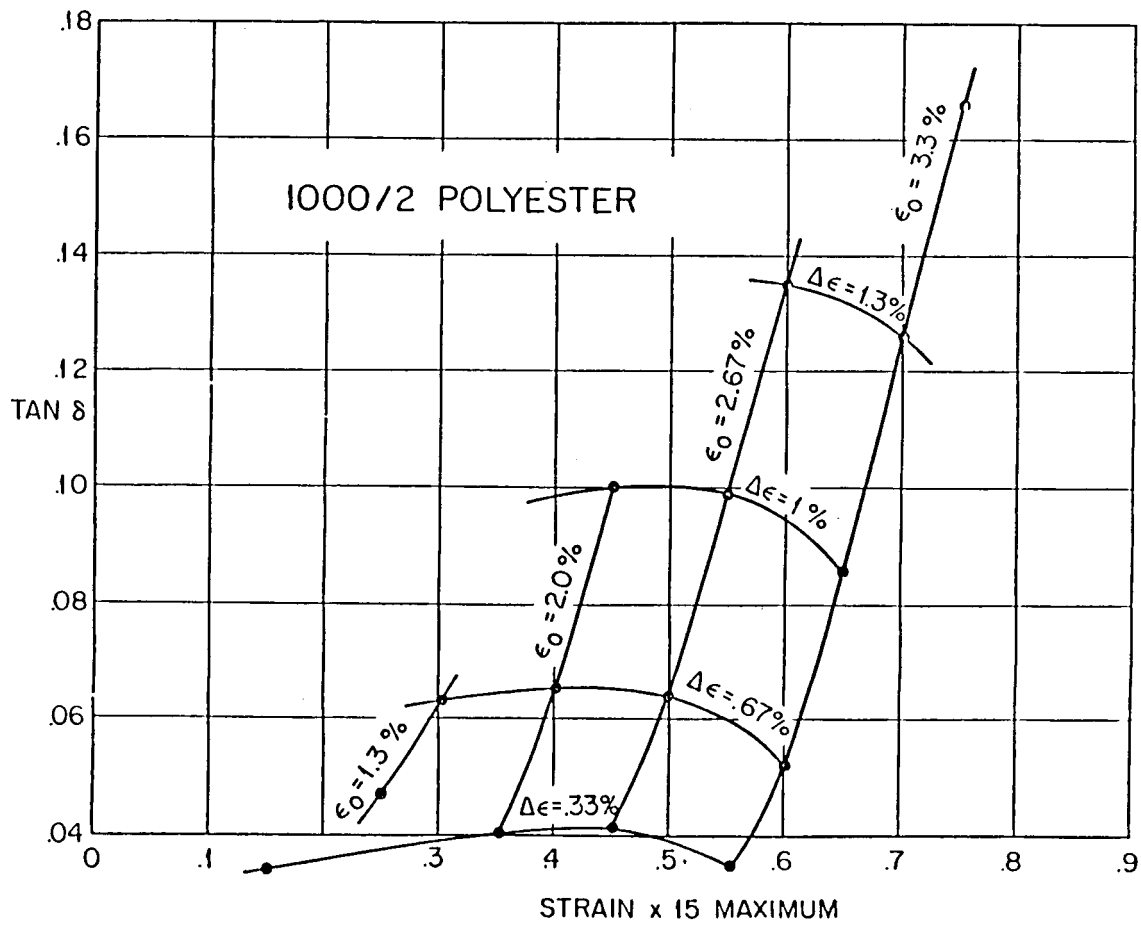

Figure 5. Carpet plot of 1000/2 polyester loss modulus.

SUMMARY ON CORDS DISCUSSION

- o Cords are structures and as such their effective properties are geometry and boundary condition dependent.
- o The effective cord properties are different when cords are embedded in the rubber matrix.
- o The calculation of the three-dimensional effective properties by analytical homogenization is very complex and impractical.
- o The properties of some cords such as nylon are highly temperature sensitive, particularly around the glass transition temperature.
- o The properties are different in tension and compression.
- o Cords are often nonlinear and viscoelastic.

RUBBER

The physical properties of rubber compounds depend on various processing parameters and components. Here again, we are not concerned as how these properties are related to the molecular structure of the rubber and the physics of rubber vulcanization. The focus is on determination of the relevant properties by proper experiment and within the framework of continuum physics. The most important property is the elasticity of the rubber, which is distinctly different from other conventional materials. The most distinctive features of rubber elasticity are the deformability and the rapid recovery of the deformations when loads are removed. Rubber remains elastic at extension ratios of several hundred percent. Such elastic characteristics make the rubber unique in this respect. In fact, the major developments in the theory of large elastic deformations evolved around application to rubber elasticity. The rubber elasticity is an important subject in understanding finite-element analysis of such products.

RUBBER ELASTICITY

To understand rubber elasticity, we may first examine the thermodynamics of reversible processes. The first and the second laws of thermodynamics state that (5)

$$dE = Tds + dw$$

where E is the internal energy, T is the absolute temperature, S is the entropy and w is the work done on the system. Experimental work has shown that the rubber elasticity resides basically in the entropy term. The rubber elasticity therefore has an entirely different molecular origin than other elastic materials whose elasticities are primarily associated with the increase in internal energy through changes in molecular or atomic spaces.

Much work has been carried out to formulate rubber elasticity. One example of the molecular approach is one which considers the molecular chain length having Gaussian distribution. The elasticity parameters are calculated from such quantities as finite molecular length and molecular weight between crosslinks. The entropy change resulting from Gaussian theory leads to

$$\Delta S = -\frac{1}{2}NK (\lambda_1^2 + \lambda_2^2 + \lambda_3^2 - 1)$$

in which N is the number of network chains per unit volume and λ_1 , λ_2 , and λ_3 are the three principal extension ratios along the three mutually perpendicular axes of strain for pure homogeneous strains.

The above equation provides a first order approximation to rubber elasticity but is not adequate over a large range of deformations.

PHENOMENOLOGICAL APPROACH

An entirely different approach (6) is the phenomenological approach of continuum mechanics. In this approach, the existence of a strain energy function is postulated. It has been shown that such a strain energy function should depend on deformation gradients. The equations for isotropic incompressible elastic media are as follows:

$$W = W (I_1, I_2, I_3)$$

$$I_1 = \lambda_1^2 + \lambda_2^2 + \lambda_3^2$$

$$I_2 = \lambda_1^2 \lambda_2^2 + \lambda_1^2 \lambda_3^2 + \lambda_2^2 \lambda_3^2$$

$$I_3 = \lambda_1^2 \lambda_2^2 \lambda_3^2$$

For the incompressible case

$$W = W (I_1, I_2)$$

$$I_3 = 1$$

In series form

$$W = \sum_{ij} C_{ij} (I_1 - 3)^i (I_2 - 3)^j \quad i, j = 0, 1, 2, \dots$$

An alternative form, suggested in (7), is as follows

$$W = \bar{W}(\lambda_1) + \bar{W}(\lambda_2) + \bar{W}(\lambda_3)$$

The stress-strain relations in the principal directions (the stresses are force per deformed area) are

$$\sigma_1 = \frac{\partial W}{\partial I_1} (2\lambda_1^2)^2 + \frac{\partial W}{\partial I_2} 2\lambda_1^2 (\lambda_1^2 + \lambda_3^2) + h(O)$$

$$\sigma_2 = \frac{\partial W}{\partial I_1} (2\lambda_2^2) + \frac{\partial W}{\partial I_2} 2\lambda_2^2 (\lambda_1^2 + \lambda_3^2) + h(O)$$

$$\sigma_3 = \frac{\partial W}{\partial I_1} (2\lambda_3^2) + \frac{\partial W}{\partial I_2} 2\lambda_3^2 (\lambda_1^2 + \lambda_2^2) + h(O)$$

The one-dimensional stress-strain relation can be obtained from the three-dimensional relations as shown in figure 6.

$$\sigma = 2 (\lambda^2 - 1/\lambda) \left(\frac{\partial W}{\partial I_1} + \frac{1}{\lambda^2} \frac{\partial W}{\partial I_2} \right)$$

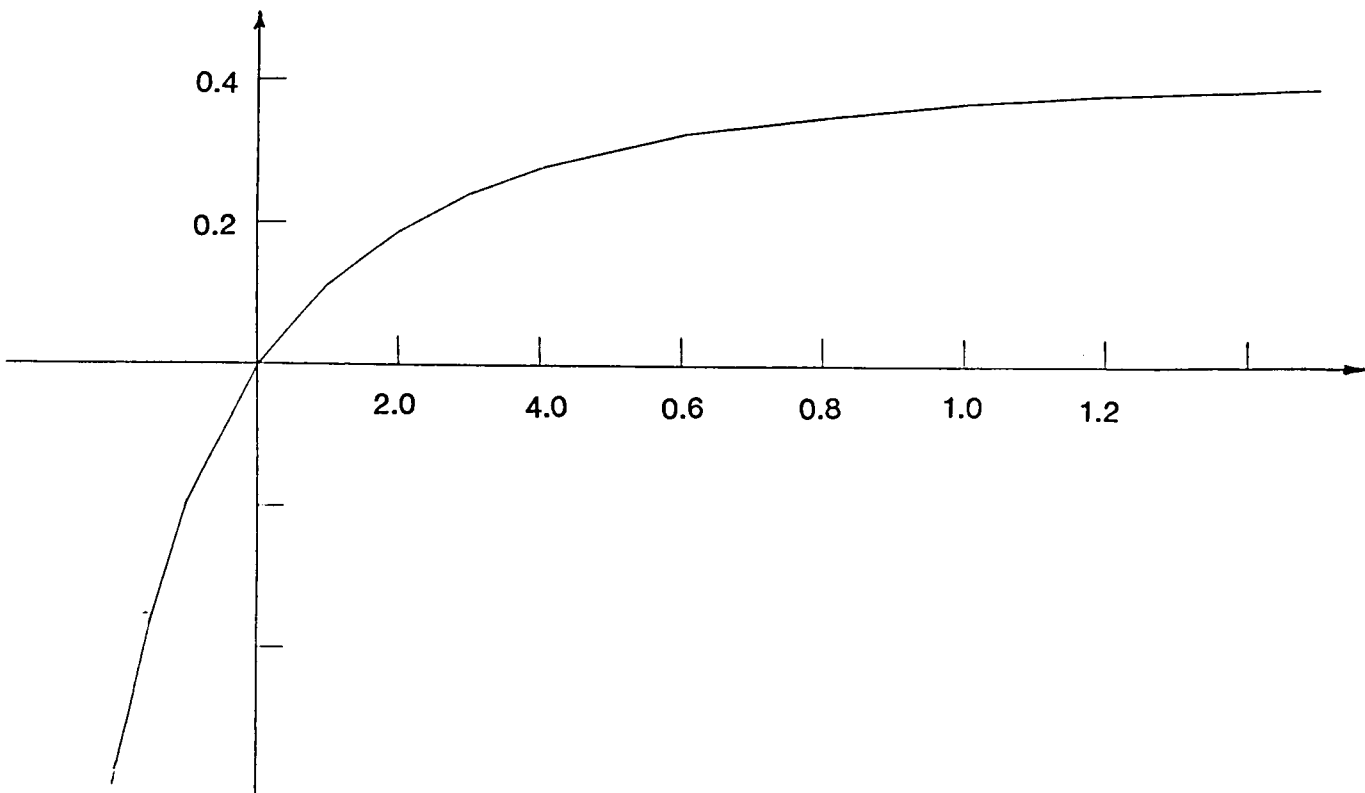

Figure 6. One-dimensional stress-strain relation.

It can be seen that the tangent compressive moduli increase significantly as the compressive strain increases. This feature realistically describes the rubber response in compression. In the finite-element treatment of rubber materials, the rubber is often modeled as linear, on the ground that the strains are small and that the linear constitutive law should then provide a reasonable approximation. This view is very disputable. It suffices to say that the compressive strains remain small due to stiffening of rubber in compression. This feature can only be handled properly by nonlinear constitutive laws. In the linear model of rubber, the material stiffness remains unchanged and therefore moderate compressive forces produce high compressive strains that are not seen in the actual structure. Such exceedingly large strains result in distortion of elements which quickly leads to severe numerical problems.

A difficult problem, in dealing with rubber elasticity, arises from the incompressibility constraint condition. The incompressibility condition leads to certain simplifications in the exact analysis of the problem, basically because of reduction in the number of unknown parameters. Such is not, however, the case with the finite-element approach. In the variational formulation, for example, the Lagrange multiplier introduces an additional unknown scalar function into the finite-element formulation. This unknown should be accommodated at the element level. The procedure results in a significant increase in the number of total unknowns and also may result in an ill-conditioned stiffness matrix. A great deal of research has been carried out to find the most suitable element for handling incompressibility. The subject is still open but the fact remains that the incompressibility imposes an additional burden in numerical analysis. The incompressibility condition, aside from being inconvenient in the finite-element analysis, is an approximation for rubber-like materials. Such an approximation becomes increasingly less accurate as the percentage of carbon black increases in the rubber compound. The exact enforcement of incompressibility is therefore not actually needed.

NEARLY INCOMPRESSIBLE MATERIALS

The strain energy function for nearly incompressible materials can be obtained by a series expansion of the strain energy function about $(I_3 - 1)$, and retaining the leading terms of up to second order in $(I_3 - 1)$, as follows

$$W = W_1 (I_1, I_2) + W_2 (I_1, I_2) \cdot (I_3 - 1) \\ + W_3 (I_1, I_2) \cdot (I_3 - 1)^2 + \dots$$

$$|I_3 - 1| \ll 1$$

$$W = \sum_{ij} C_{ij} (I_1 - 3)^i (I_2 - 3)^j + W_2 - (I_3 - 1) + W_3 (I_3 - 1)^2 + \dots$$

One special case of the above equations is when the function W_2 and W_3 are considered constants. The constants are described as follows:

$$W_2 (I_1, I_2) = H_1$$

$$W_3 (I_1, I_2) = H_2$$

$$H_1 = -(C_{10} + 2C_{01})$$

The near incompressibility can now be enforced by assigning large values to H . In fact, as H approaches infinity, (I_{3-1}) approaches zero so that the strain energy remains finite. The higher the value of H , the closer the incompressibility would be satisfied. H is referred to as the penalty number. In finite-element analysis, however, the large values of H can lead to overriding stiffness which results in numerical problems. The penalty method nevertheless permits the satisfaction of near incompressibility without increasing the number of unknowns in finite-element formulation. Figure 7 shows a set of typical properties for the rubber.

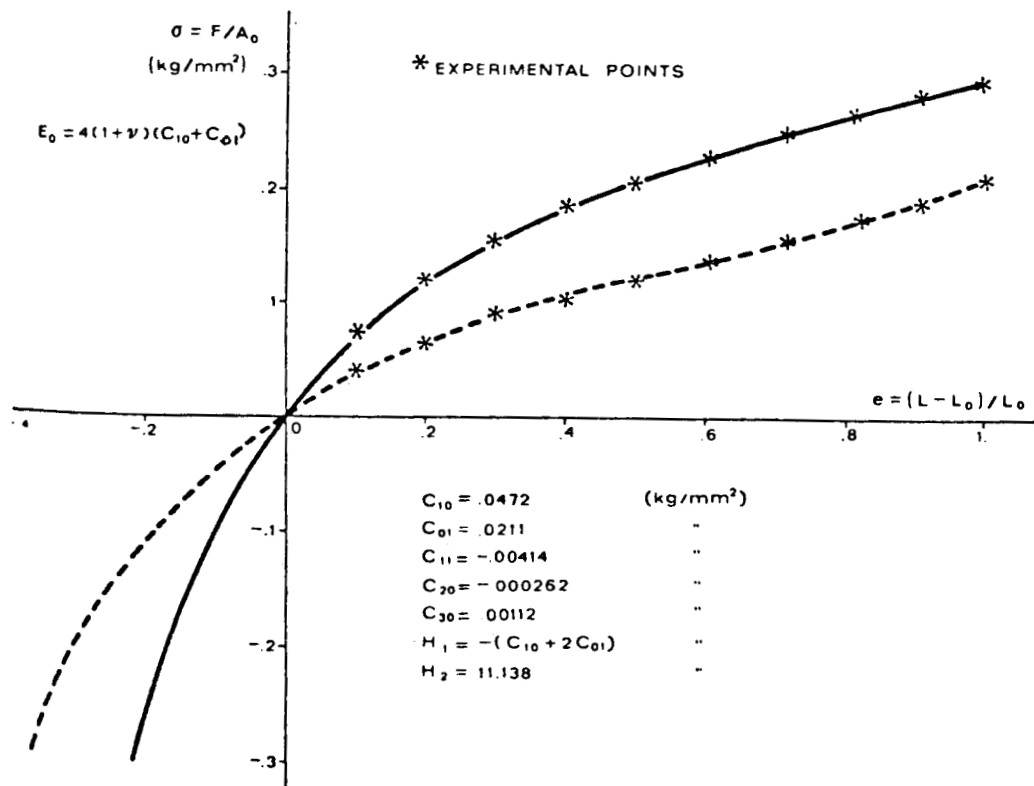

Figure 7. Stress-strain relation, (8).

FRACTURE AND FATIGUE PROPERTIES

The fatigue of the rubber has been the subject of many investigations in the past. The rubber fatigue is intimately related to the nature of rubber fracture and cut growth. The fracture mechanics approach for rubber was first adopted by Rivlin and Thomas (9) and Thomas (10) who promoted the concept of the tear energy in describing the cut growth mechanism. The tear energy approach has been applied to the study of the crack growth problem and to the description of fatigue behavior of rubber. We only consider the mechanically induced fatigue and this therefore excludes the fatigue caused by or resulting from non-mechanical sources such as aggressive environment. Some of the non-mechanical sources, such as ozone cracking in elastomers, may, however, be more damaging than mechanical sources.

Busse's early results (11) on NR compounds, shown in Table 5, clearly demonstrate the unique feature of rubber fatigue.

Table 5

EFFECT OF STRAIN CYCLE

STRAIN CYCLE	LIFE, MINUTE
5 - 60% Extension	10
10 - 60% "	25
15 - 60% "	90
17 - 60% "	150+
20 - 60% 00	00

Some experimental fatigue data on various compounds are shown in Figures 8 to 11 taken from References (12-14).

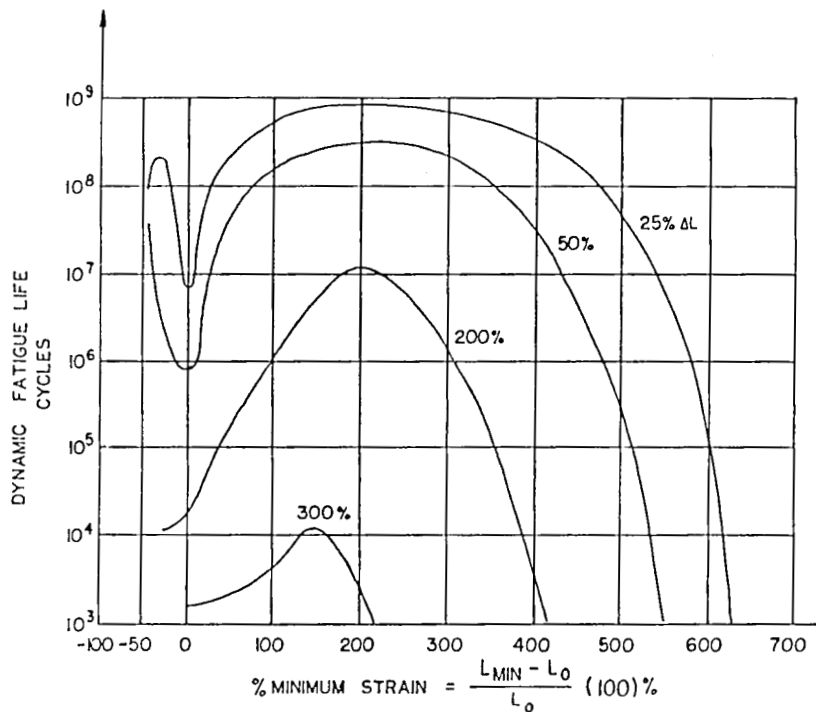

Figure 8. Fatigue life of NR as a function of minimum strain range (from ref. 12).

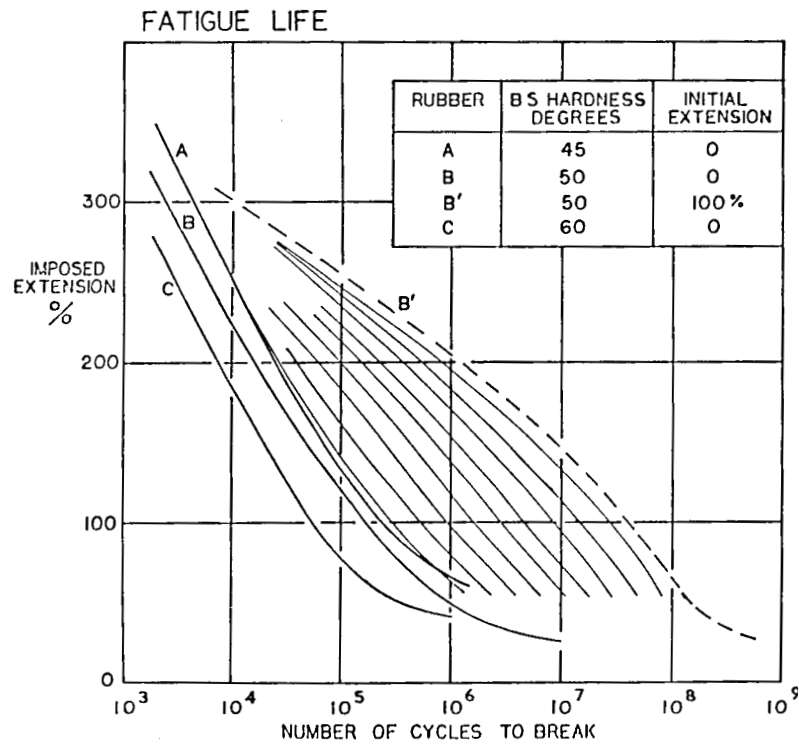

Figure 9. Imposed extension versus number of cycles to break (from ref. 12).

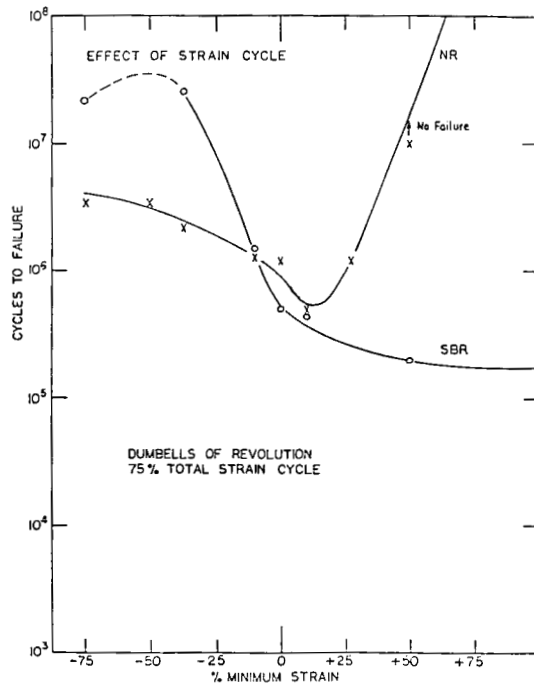

Figure 10. Cycle of failure versus minimum strain for NR and SBR (from refs. 13 and 14).

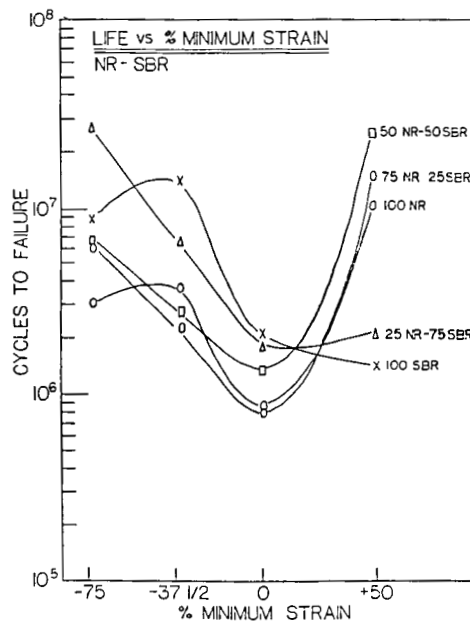

Figure 11. Cycle of failure versus minimum strain for various compositions (from refs. 13 and 14).

SUMMARY ON RUBBER

- o Rubber remains elastic at extension ratios of several hundred.
- o Rubber is almost incompressible.
- o The rubber elasticity can be most conveniently expressed through the strain energy function.
- o Rubber has unique fatigue properties. Extensive experimental work needs to be carried out for fatigue characterization of various rubber compounds.
- o Appropriate failure theories are needed for interpretation of stress data from finite-element analysis.
- o Properties are temperature dependent.

CORD REINFORCED RUBBER COMPOSITE - SINGLE PLY

In the macro-mechanics approach to composites, the actual heterogeneous medium, Figure 12, is replaced by an "equivalent" homogeneous medium. The equivalent medium has the same geometry as the heterogeneous medium but different material properties. The "effective" properties of the latter may belong to a different class of symmetry than those of the constituent materials. For instance, for isotropic constituents, the effective properties may be isotropic, orthotropic or anisotropic depending on the internal geometry of the composite.

Let us consider a two-dimensional composite made of an isotropic matrix and reinforced by doubly periodic arrays of isotropic fibers as shown in Figure 13. A composite representation of the problem is a homogeneous medium with the same external geometry and boundary conditions as those of the heterogeneous case, but with orthotropic properties. The effective orthotropic properties are then defined for a "representative" element. It is very important to first understand what is meant by that. Hashin (15) defined and discussed this question and has drawn some analogies to the case of homogeneous continua. In such continua, the hypothesis is that the continua retain their properties even for infinitesimal elements. Due to the discrete nature and microstructure of homogeneous media, the infinitesimal element of continuum mechanics should be large compared to the scales of the microstructure. The infinitesimal element therefore exhibits properties which are some statistical averages of the microstructure properties. On the other hand, the infinitesimal elements should be very small compared to the dimensions of the continua. It then follows that the physical quantities at a point, such as moduli, stress and strain components, are in reality associated with averages over infinitesimal elements and not with a geometrical point. Due to the complex nature of the microstructure, the properties of the continuum infinitesimal elements are determined experimentally as opposed to calculating the averages from a microstructural theory. The same comments also apply to the "representative" element of composite theories, that is to say that a "representative" element is the infinitesimal element of composite materials. It therefore should be large compared to the dimensions of its material phases. A "representative" element, as defined, would retain and represent the properties of the composite continua and furthermore these properties would be insensitive to boundary conditions.

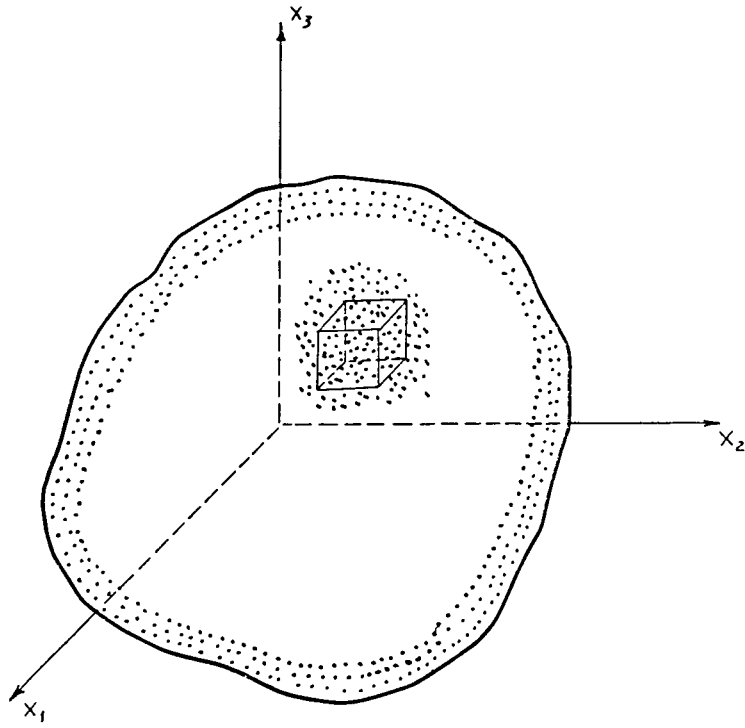

Figure 12. Representative element.

A distinction must be made between a "representative" element and unit elements or unit cells. The latter is defined as building blocks, so that the continua can be constructed by repeated use of such units. For example, consider the composite of Figure 13. There are a number of unit cell configurations which can equally serve as building blocks. Some of these possible choices are shown in Figure 14. Figure 15 shows the boundary effects on shear deformations. The average properties of these units, unlike those of a "representative" element, are highly boundary condition dependent (16). A "representative" element, however, consists of a large number of unit cells.

From the definition of a "representative" element, it is apparent that the properties calculated or experimentally measured would be rather insensitive to boundary conditions. The problem, however, is that such a calculation would be a formidable task. Most published works dealing with a calculation of effective properties use a unit cell as the basis of their computations. Even for unit cells, the exact solutions can be obtained for only some simple geometries and simple boundary conditions. Another approach adopted is to determine the upper and the lower bounds for these properties through approximate solutions of energy formulations. These bounds are, however, far apart for composites with high cord-to-matrix stiffness ratios, such as rubber composites, and are therefore of little practical use.

The immediate question is, therefore, how sensitive these properties are to boundary conditions specified over the surface of the unit cell, and, furthermore, how the element boundary conditions are influenced by global boundary conditions. These questions have not been fully investigated in the literature. It can, however, be stated that such sensitivities should depend on the relative stiffnesses of the cord and the matrix. As the stiffness of the matrix approaches that of the reinforcing materials, the effective properties should become less sensitive to boundary conditions and obviously independent of the boundary conditions in the limiting case of identical constituents' properties. These sensitivities are thus of greater concern in rubber composites than conventional rigid composites. The ratio of cord to rubber stiffness can exceed 30,000 in some composites which is far greater than those of rigid composites.

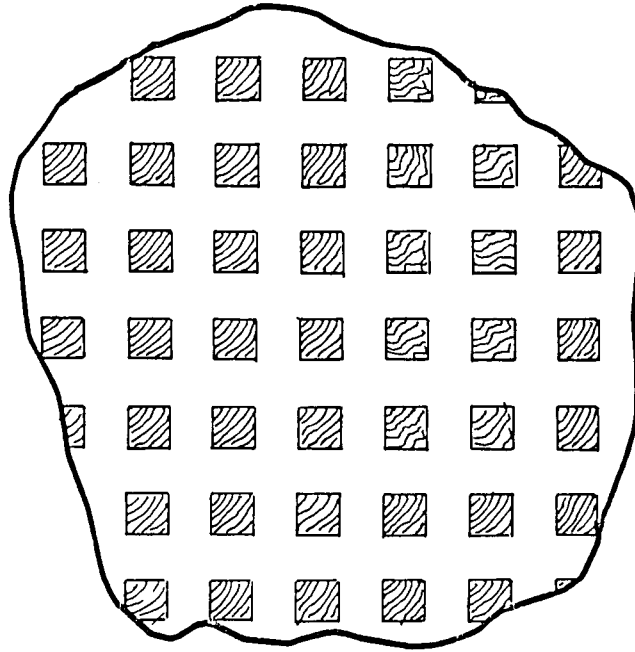
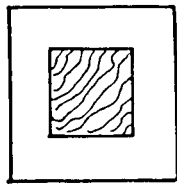
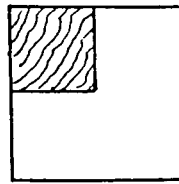

Figure 13. Composite with doubly periodic fiber arrays.



(I)



(II)

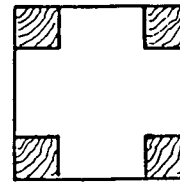

(III)

Figure 14. Several unit cells.

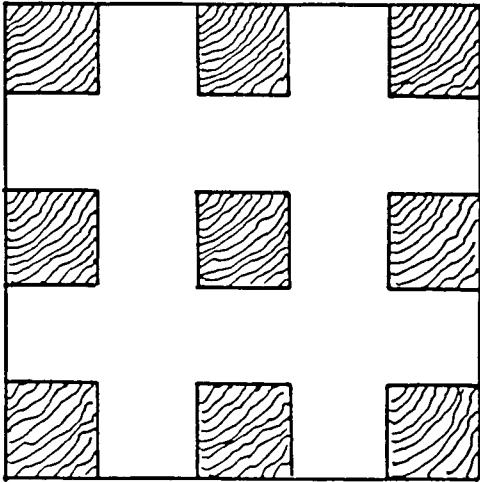

(a) Undeformed

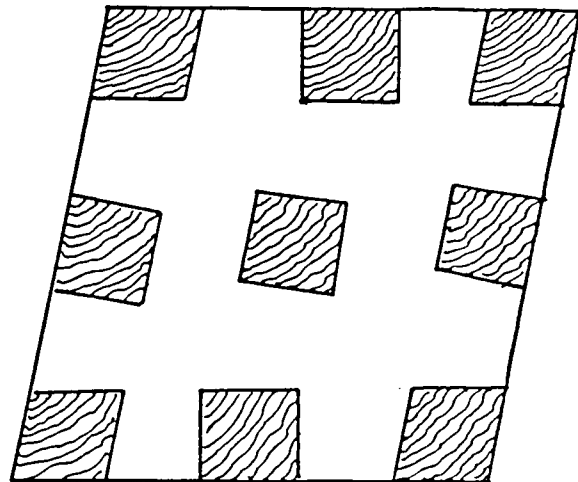

(b) Deformed

Figure 15. Uniform shear strain boundary condition.

SUMMARY ON BASICS OF RUBBER COMPOSITES

- o The calculation of effective properties of rubber composites by homogenization is subject to more limitations than rigid composites. These limitations need to be established on a sound theoretical basis.
- o In experimental determination of the effective properties, the effects of size and the boundary conditions should be investigated.
- o The homogenized properties of a single ply cannot be easily calculated since all the 3-D homogenized cord properties are not generally available, with sufficient accuracy. Some of the effective composite properties, however, may prove to be somewhat insensitive to inaccuracies in cord properties.
- o A necessary characteristic of a composite material is statistical homogeneity. A representative element, used for calculation of the effective properties, should be large compared to typical phase regions. A representative element of a single ply does not have such a characteristic in the thickness direction. The out of plane properties of a single ply, therefore, are subject to question.
- o The effective properties are different in tension and compression.

CHARACTERIZATION OF LAMINATED COMPOSITES

We now consider a laminated structure, composed of N layers of cord-reinforced composite materials, as shown in **Figure 16**. Each layer of heterogeneous composite may then be modeled as homogeneous but orthotropic with respect to the proper local coordinate of each layer. The constitutive equations of the laminated composite, however, must be obtained with respect to a global coordinate system XYZ , as shown in **Figure 16**. The transformation relations may then be used for the appropriate layers to carry out the required transformation. The layers are numbered from top to bottom and no symmetry is assumed with respect to any axis. The stress and moment resultants for the laminated structure in terms of stresses are defined as follows:

$$\begin{aligned} N_x &= \int_0^t \sigma_{xx} dz & N_y &= \int_0^t \sigma_{yy} dz & N_{xy} &= \int_0^t \sigma_{xy} dz \\ M_x &= \int_0^t \sigma_{xx} z dz & M_y &= \int_0^t \sigma_{yy} z dz & M_{xy} &= \int_0^t \sigma_{xy} z dz \\ Q_x &= \int_0^t \sigma_{xz} dz & Q_y &= \int_0^t \sigma_{yz} dz \end{aligned}$$

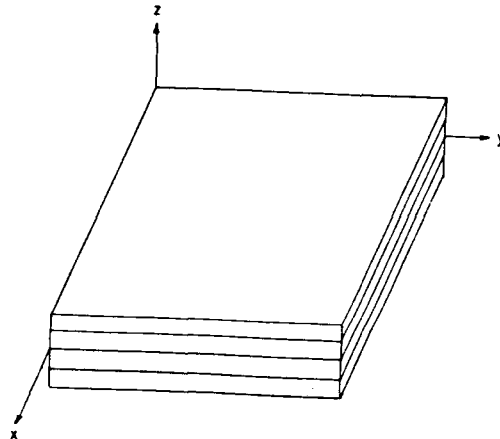

Figure 16. Geometry of typical laminated composites.

The displacement components and the resulting constitutive relations are

$$u = u_0(x, y) + zk_x(x, y)$$

$$v = v_0(x, y) + zk_y(x, y)$$

$$w = w(x, y)$$

$$\begin{bmatrix} N_x \\ N_y \\ Q_x \\ Q_y \\ N_{xy} \\ M_x \\ M_y \\ M_{xy} \end{bmatrix} = \begin{bmatrix} A_{11} & A_{12} & 0 & 0 & A_{16} & B_{11} & B_{12} & B_{16} \\ A_{12} & A_{22} & 0 & 0 & A_{26} & B_{12} & B_{22} & B_{26} \\ 0 & 0 & A_{44} & A_{45} & 0 & 0 & 0 & 0 \\ 0 & 0 & A_{54} & A_{55} & 0 & 0 & 0 & 0 \\ A_{16} & A_{26} & 0 & 0 & A_{66} & B_{16} & B_{26} & B_{66} \\ B_{11} & B_{12} & 0 & 0 & B_{16} & D_{11} & D_{12} & D_{16} \\ B_{12} & B_{22} & 0 & 0 & B_{26} & D_{21} & D_{22} & D_{26} \\ B_{16} & B_{26} & 0 & 0 & B_{66} & D_{16} & D_{26} & D_{66} \end{bmatrix} \begin{bmatrix} \frac{\partial u_0}{\partial x} \\ \frac{\partial v_0}{\partial y} \\ \frac{\partial w}{\partial y} + k_y \\ \frac{\partial w}{\partial x} + k_x \\ \frac{\partial u_0}{\partial x} + \frac{\partial v_0}{\partial y} \\ \frac{\partial k_x}{\partial x} \\ \frac{\partial k_y}{\partial y} \\ \frac{\partial k_y}{\partial x} + \frac{\partial k_x}{\partial y} \end{bmatrix}$$

where the laminate stiffnesses are related to the layer stiffness by:

$$A_{ij} = \int_0^t \sum_{k=1}^n C_{ij}^{(k)} dz \quad i, j = 1, 2, 6$$

$$B_{ij} = \int_0^t \sum_{k=1}^n C_{ij}^{(k)} z dz \quad i, j = 1, 2, 6$$

$$D_{ij} = \int_0^t \sum_{k=1}^n C_{ij}^{(k)} z^2 dz \quad i, j = 1, 2, 6$$

$$A_{ij} = \int_0^t \sum_{k=1}^n C_{ij}^{(k)} k_{ij} dz \quad i, j = 4, 5 \quad \text{No summation on } i \neq j$$

SUMMARY ON LAMINATED COMPOSITES

- o Each ply may be homogenized, subject to the same limitations as those of a single ply.
- o Complete homogenization is not possible since the coupling between the forces and the moments can only be accounted for by preserving nonhomogeneity in the thickness direction.
- o Classical kinematics constraints, such as the Kirchhoff hypothesis, do not apply.
- o Plate/shell type stiffnesses are extremely hard to measure.
- o Constitutive relations are nonlinear due to angle change between the cords of adjacent plies.

ANALYTICAL AND COMPUTATIONAL FEATURES

KINEMATICS

The rubber composite structures undergo large strains as well as large rotations. The major kinematic features are listed in table 6.

Table 6

KINEMATIC FEATURES

LARGE RUBBER STRAINS

LARGE ROTATIONS

CORD ANGLE CHANGES

NEAR INCOMPRESSIBILITY CONDITION

CONSTITUTIVE RELATIONS FOR COMPOSITES

Single ply

The single-ply composites can be considered as linear orthotropic when referred to axes of symmetry. For large displacements but moderately small strains, the rubber and the cords can be considered linear, but the strain-displacement gradient relations are nonlinear. The most appropriate form of constitutive equations, in such case, is

$${}^t S_{ij} = {}^t C_{ijkl} {}^t \epsilon_{kl}$$

where ${}^t C_{ijkl}$ are orthotropic properties referred to coordinates of initial material symmetry. The term ${}^t S_{ij}$ are the components of the second Piolla-Kirchhoff stress tensor and ${}^t \epsilon_{kl}$ are the components of the Lagrangian strain tensor. This form is invariant under a rigid body motion and therefore needs to be updated due to the cord angle change. This does not hold for constitutive equations

which utilize other stress and strain measures. The major drawback of modeling each ply separately is the increased size of the finite-element problem.

Several plies

It is often more convenient to lump several plies together in one element and therefore reduce the size of the problem. The preceding equation can be utilized but not longer remains unchanged due to the change in the angle between the minus and the plus ply. In such models the orthotropic properties of the combined plies continually change as functions of the cord angle.

Composites with nonlinear constituents

It is often necessary to account for the rubber nonlinearities in the finite-element analysis, even for small strains. The reason for such a need is that the typical compressive forces can produce large rubber strains if the rubber stiffening is not properly accounted for in the material modeling. These unrealistic large strains may lead to element distortion and eventual loss of numerical stability in the finite-element model. No rigorous nonlinear composite constitutive equations have appeared in the literature for rubber composites. This awaits further research in this field.

Various modeling levels may be required depending on the nature of the problem. These models and their respective features are listed in Table 7.

Table 7

MODELING FEATURES

<u>ELEMENT TYPE FOR COMPOSITES</u>	<u>FEATURES</u>
MEMBRANE ELEMENTS	REQUIRES 2-D MATERIAL PROPERTIES, INTERPLIES MODELED INDEPENDENTLY ONE ELEMENT PER PLY AND ONE ELEMENT PER INTERPLY IN THE THICKNESS DIRECTION, NO NEED FOR MATERIAL UPDATE DUE TO THE CORD ANGLE CHANGE
TWO- AND THREE-DIMENSIONAL ELEMENTS REPRESENTING:	
SINGLE PLY	REQUIRES 3-D MATERIAL PROPERTIES, ONE ELEMENT PER PLY IN THICKNESS DIRECTION, NO NEED FOR MATERIAL UPDATE DUE TO THE CORD ANGLE CHANGE
SEVERAL PLYS	REQUIRES 3-D MATERIAL PROPERTIES, LESS ELEMENTS, MATERIAL PROPERTIES MUST BE UPDATED DUE TO THE CORD ANGLE CHANGE, CANNOT MODEL THE COUPLING BETWEEN THE BENDING AND IN-PLANE FORCES
SHELL-TYPE ELEMENTS	INCREASED MATERIAL PROPERTY INPUT, LEAST NUMBER OF ELEMENTS, CAN MODEL THE COUPLING BETWEEN THE BENDING AND IN-PLANE FORCES, KINEMATICS CONSTRAINTS OF THE CORRESPONDING SHELL THEORY, MATERIAL PROPERTIES MUST BE UPDATED DUE TO THE CORD ANGLE CHANGE

SUMMARY OF MAJOR ANALYTICAL AND COMPUTATIONAL NEEDS AND FEATURES

- o Large elastic strains.
- o Large rotations.
- o Incompressibility condition, natural rubber can be considered as incompressible, but filled rubber exhibits compressibility.
- o Nonconservative loading.
- o Element type and aspect ratio.
- o Self-adoptive schemes for load increments and step size.
- o Contact algorithms for frictional loadings.
- o Finite-element formulation in rotating coordinate system.
- o Substructuring for localized analysis.
- o Stresses are very erratic at regions of sudden change in stiffness, such as cord-rubber interface. When calculated from the finite-element displacement method, proper smoothing algorithms must be developed for nonlinear problems.
- o Sensitivity analysis for uncertain input, material properties or other variables.

REFERENCES

1. Riding G. "Study of the Geometrical Structure of Multi-Ply Yarns," *Journal of Textile Institute*, vol. 52, pp. 366-381, 1961.
2. Clark, S.K., "Mechanics of Pneumatic Tires," National Bureau of Standards Monograph 122, First Edition, 1971.
3. Oblath, R.M., "Toward 21st Century - The Challenges Ahead of Tire Reinforcements," Akron Rubber Group, Akron, Ohio, Jan. 26, 1984.
4. Tabaddor, F. and Clark, S.K., "Linear and Nonlinear Viscoelastic Constitutive Relations of Cord Reinforced Elastomers," Proceedings of the International Symposium on Constitutive Equations for Non-Linear Materials, University of Arizona, Tuscon, Jan. 1983.
5. Treloar, L.R.G., "The Elasticity of a Network of Long Chain Molecules (I and II)," *Trans. Faraday Society*, vol. 40, p. 59, 1944.
6. Rivlin, R.S. and Saunders, D.W., "Large Elastic Deformations of Isotropic Materials - VII. Experiments on the Deformation of Rubber," *Phil. Trans. Royal Society*, vol. A243, p. 251, 1948.
7. Valanis, K.C. and Landel, R.F., "The Strain Energy Function of a Hyper-Elastic Material in Terms of the Extension Ratios," *Journal of Applied Physics*, vol. 38, no. 7, pp. 2997-3002, 1967.
8. Tavazza, G. and Rimondi, G., "Stress and Strain Calculations of Rubber Goods," Proceedings of the International Rubber Conference, Kiev USSR, 1978.
9. Rivlin, R.S. and Thomas, A.G., *J Polymer Science*, vol. 10, p. 291, 1953.
10. Thomas, A.G., *J. Polymer Science*, vol. 31, p. 467, 1958.
11. Busses, W.F., *Ind. Eng. Chem.*, vol. 26, p. 1194, 1934.
12. Cadwell, S.M., Merril, R.A., Sloman, C.M. and Yost, F.L., *Ind. Eng. Chem. Anal.*, vol. 12(1), p. 19, 1940.
13. Beatty, J.R., *Rubber Chemistry and Technology*, no. 5, pp. 1341-1346, Dec. 1964.
14. Beatty, J.R., *J. of Elastomers and Plastics*, vol. 11, p. 147, April 1974.
15. Hashin, Z., "Analysis of Composite Materials--A Survey," *Journal of Applied Mechanics*, vol. 50, September 1983.

16. Tabaddor, F., "Mechanical Properties of Cord-Rubber Composites," Composite Structures, vol. 3, pp. 33-53, 1985.