

**N89-25160**

# **DEMONSTRATION OF DECOMPOSITION AND OPTIMIZATION IN THE DESIGN OF EXPERIMENTAL SPACE SYSTEMS**

Sharon L. Padula  
NASA Langley Research Center  
Hampton, VA

Chris A. Sandridge  
Virginia Polytechnic Institute and State University  
Blacksburg, VA

Raphael T. Haftka  
Virginia Polytechnic Institute and State University  
Blacksburg, VA

Joanne L. Walsh  
NASA Langley Research Center  
Hampton, VA

## INTRODUCTION

Effective design strategies for a class of systems which may be termed Experimental Space Systems (ESS) are needed. These systems, which include large space antenna and observatories, space platforms, earth satellites and deep space explorers, have special characteristics which make them particularly difficult to design. This paper will argue that these same characteristics encourage the use of advanced computer-aided optimization and planning techniques.

The broad goal of this research is to develop optimization strategies for the design of ESS. These strategies would account for the possibly conflicting requirements of mission life, safety, scientific payoffs, initial system cost, launch limitations and maintenance costs. The strategies must also preserve the coupling between disciplines or between subsystems. For instance, the strategies must recognize that changes in the structural design influence the selection of materials and the design of the control system. This research is unique because it focuses on optimization of multidisciplinary system design problems and because it emphasizes automated decomposition of these system design problems.

The specific purpose of the present paper is to describe a computer-aided planning and scheduling technique. This technique provides the designer with a way to map the flow of data between multidisciplinary analyses. The technique is important because it enables the designer to decompose the system design problem into a number of smaller subproblems. The planning and scheduling technique is demonstrated by its application to a specific preliminary design problem.

## **CHARACTERISTICS OF EXPERIMENTAL SPACE SYSTEM DESIGN**

Experimental space systems have special characteristics which make them difficult to design. Many of these characteristics are a function of the unique environment in which ESS operate. Space-based hardware must perform flawlessly in microgravity, yet must withstand ground-based handling and high launch loads. Exposed to unusual temperature and radiation extremes, they must continue to operate for extended periods of time without servicing. These unique operating conditions call for special mechanisms, built with unusually small tolerances to manufacturing errors. Often, the ESS must be constructed from exotic materials and must be designed to meet weight and packaging constraints.

The design of ESS is further complicated by the fact that these are often "one-of-a-kind" projects. Space satellites and probes are designed to answer questions about our universe. If the original mission is a success, then it need not be repeated. If the mission fails to operate or returns unexplained results, then the system must be redesigned.

Designing "one-of-a-kind" projects is essentially different from the usual task of improving an existing product to meet new specifications. First, there is no body of collected information to consult and there is limited expertise acquired from related experiences. Thus, the designer has less confidence in his intuitive design decisions. Building and testing of prototype designs might supply some of this missing information but this is not always possible. Prototypes are very expensive and hard to justify for a "one-of-a-kind" mission. Moreover, if prototypes are constructed, testing them on the ground to predict their operation in space is problematic if not impossible.

The effect of these characteristics of ESS is an emphasis on analytic prediction of performance and a need for more systematic methods of design.

### **UNIQUE OPERATING CONDITIONS REQUIRE:**

- Special mechanisms**
- Exotic materials**
- Extreme precision**
- Low structural weight**

### **"ONE-OF-A-KIND" PROJECTS IMPLY:**

- No collected body of Information**
- Few "rules of thumb"**
- Prototypes hard to justify**
- No standardized test procedures**

## OPTIMIZATION AS A DESIGN TOOL

There are many reasons to believe that optimization will have an expanded roll in future ESS design. First, it is necessary to rely on analytic prediction of the system behavior. Thus, integration of existing optimization and analysis codes should be practical. Second, ESS design involves many interrelated subsystems, many independent design variables and extremely stringent constraints. Thus, formal optimization may be the only practical way to find a feasible design. Finally, ESS designs are costly to manufacture and launch. A design which can be improved via optimization may result in substantial savings.

There are problems with the use of optimization in ESS. The most obvious problem is that optimization requires repeated execution of the system analysis codes. Often these codes require large amounts of computer resources for even a single execution. Another problem is that the performance of optimization codes often degrades as the number of design variables grows. A final problem is that optimization techniques work best when a single goal can be unambiguously defined. There is no accepted way to deal with the multiple conflicting goals which are required by the current state of the art in ESS design.

Optimization, including mathematical programming and optimal control, has been successfully employed in past experimental space system projects [1-3]. However, for the most part, optimization is used to refine some component of a nearly completed design.

Current optimization research involves extending the use of optimization to the preliminary design of an overall system [4-7]. Formulating the problem correctly is the most difficult part of system optimization. Unfortunately, tricks which facilitate optimization of one problem do not automatically apply to the next one.

### AFFIRMATIVE

**Analytical models exist**

**Feasible designs not obvious**

**Substantial savings possible**

### NEGATIVE

**Enormous compute times**

**Numerous design variables**

**Multiple conflicting goals**

## THE COFS EXPERIMENT

A specific example of an experimental space system is used to illustrate the points to be made in this paper. Control of Flexible Structures (COFS) was a project initiated by NASA Langley to develop validated technology for the control of future large space structures [8,9]. The COFS I Mast Flight System (MFS) is a truss structure, attached to the shuttle, used to study techniques for system identification and active control. It must be designed to maximize the value of scientific data collected while minimizing cost and weight of the structure. Moreover, the system must be safe and reliable to operate and must withstand adverse conditions during launch and deployment.

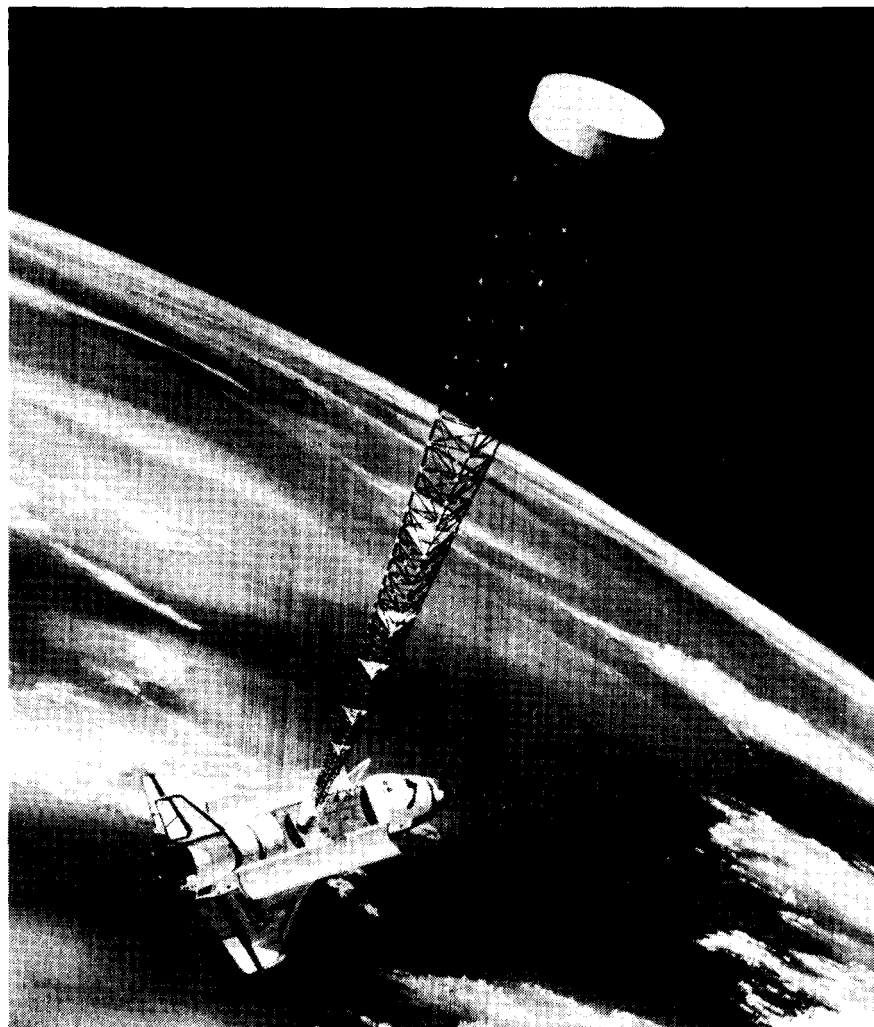

~~ORIGINAL PAGE  
BLACK AND WHITE PHOTOGRAPH~~

ORIGINAL PAGE  
BLACK AND WHITE PHOTOGRAPH

## MULTILEVEL DECOMPOSITION

One promising technique for optimizing a multi-objective system such as the COFS I Mast Flight System is called multilevel decomposition [10]. This technique divides the total system optimization problem into subproblems, each with its own objective and with a reduced number of design variables. For instance, the COFS I problem might be divided into 3 subproblems. The first is to design the structure for minimum weight, the second is to design the control system minimizing a composite objective based on cost and control effort and the last is to design the placement of sensors and the application of dynamic loads to increase the value of the scientific data collected. All of these subproblems must be coordinated so that the final design is feasible and so that the cost of the project is minimized.

Several techniques for solving multilevel problems exist. At least one technique has been tested for a complicated system with a great number of design variables and has proved to be quite effective [11].

The present techniques for multilevel optimization do not include a strategy for decomposing a given system into subproblems. Merely drawing the figure below is insufficient. It is necessary to identify the design variables, analysis steps and constraints which are associated with each subproblem. A first step toward automatic decomposition is described in reference 12. This technique uses the sensitivity derivatives of the multiple objectives to decompose the system. Reference 12 describes an application where each of the objectives is nominally a function of each design variable and where each objective is computationally similar. The present research emphasizes system design problems having many dissimilar objectives, each of which is a function of some subset of all design variables.

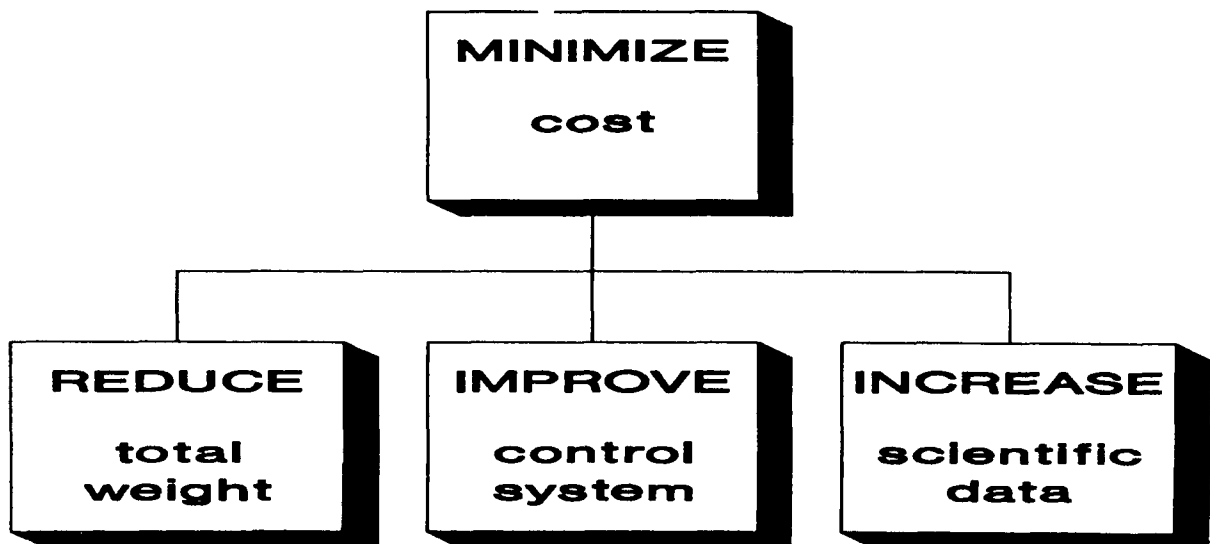

## PLANNING AND SCHEDULING (P&S) TECHNIQUE

This paper explores the use of automatic planning and scheduling (P&S) techniques to assist in the decomposition. These techniques were originally developed as project management tools [13]. They can reorder a set of tasks so that all prerequisites are available when a given task is begun. The input to the P&S computer program is a list of tasks with their prerequisites. The output can be a network graph such as the one in the figure.

In the network graph below, notice that task 2 must be completed before task 4 can begin. This is indicated by the circle at the intersection of lines which exit horizontally from the box marked 2 and enter vertically the box marked 4. Indirectly, task 2 is also a prerequisite to task 5 because task 4 must precede 5 and 2 must precede 4.

A slightly unusual feature of this particular network is the feedback path from task 7 to task 4. This indicates that tasks 4,5,6 and 7 are their own prerequisites. Such a set of tasks is called a circuit. Some P&S programs can identify circuits and temporarily replace them with a single task so that the network graph can be completed. The presence of circuits in a network graph alerts the project manager that this set of tasks may have to be repeated several times before the results are satisfactory.

A planning and scheduling computer program which can handle circuits may be a useful decomposition tool. If the tasks in this network are thought of as design variables and constraints then circuits can be interpreted as optimization loops. This idea will be illustrated using the COFS I MFS example.

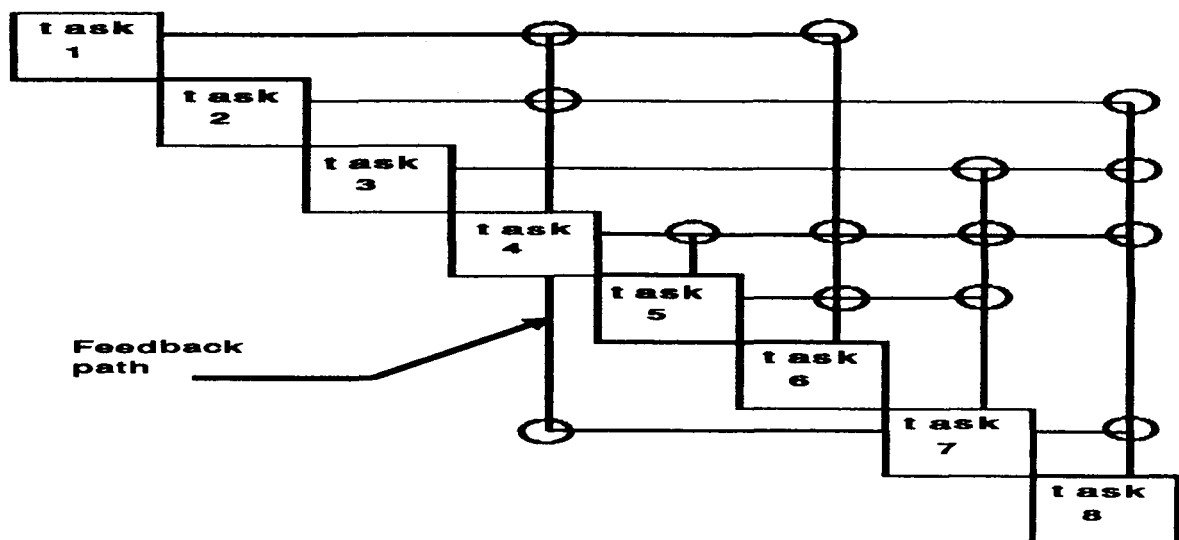

## COFS I MINI-EXAMPLE

First, consider a much simplified version of the COFS I experiment. Assume that the problem is to design a space truss for testing system identification techniques. The ultimate objective is to reduce the cost of the system. Other objectives are to design a structure that can carry the required loads and which is challenging to test based on its closely spaced vibrational frequencies.

**minimize:**

**SYSTEM COST**

**subject to:**

- (1) STRUCTURE FEASIBLE**
- (2) SYSTEM I.D. INTERESTING**

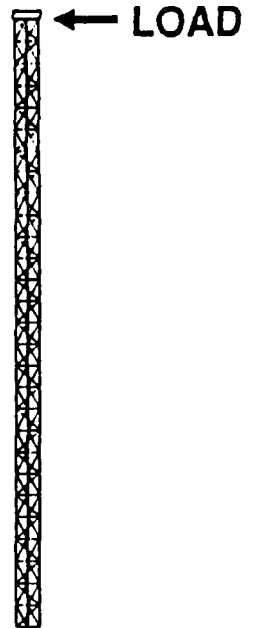



## P&S STEP 1. LIST DESIGN VARIABLES

In order to apply planning and scheduling to the COFS I problem, first the design variables ( $v_i$ ) must be identified. There are many possible design variables, but the length of one bay of the truss and the number of bays in the MFS are certainly important. Other possibilities are the diameter and thickness of truss elements and the number and location of sensors. Notice that some of the variables mentioned are scalars while others, such as the location of all sensors, are arrays. This is done to condense the amount of information processed by the planning and scheduling program. It will not be a problem if all the elements in the array are updated and used as a group.

<u>symbol</u>	<u>meaning</u>
v1	length of bay
v2	number of bays
v3	number of sensors
v4	truss element sizes
...	...

## P&S STEP 2. LIST BEHAVIOR VARIABLES

The next step is to identify important quantities which are calculated from known values of the design variables. For the purpose of this paper, these calculated quantities will be termed behavior variables ( $b_i$ ). Examples are the bending stiffness of the beam and the extra weight associated with the joints between elements. For instance, the symbol  $b_3$  is used to represent the results of an eigenvalue analysis routine. That is,  $b_3$  represents all of the mode shapes and vibration frequencies of the MFS.

<u>symbol</u>	<u>meaning</u>
<b>b1</b>	<b>bending stiffness</b>
<b>b2</b>	<b>extra weight of joints</b>
<b>b3</b>	<b>mode shapes &amp; frequencies</b>
...	...

### P&S STEP 3. LIST GOALS AND CONSTRAINTS

The next step in applying planning and scheduling is to quantify all known constraint functions ( $g_i$ ). The COFS I experiment has constraints on the total weight of the system and on the vibration frequencies of the MFS and of the individual truss elements.

<u>symbol</u>	<u>meaning</u>
<b>g1</b>	<b>total wt &lt; allowable</b>
<b>g2</b>	<b>member freq. &gt;&gt; mast freq.</b>
<b>g3</b>	<b>fundamental freq. near target</b>
<b>g4</b>	<b>closely spaced frequencies</b>
...	...

#### P&S STEP 4. PREPARE INPUT

The final step is to prepare the input to the planning and scheduling program. For each design variable, behavior variable and constraint function, there is a separate line in the input file. This line contains a symbol, an alphanumeric name and a list of dependencies. For example, the last line in the figure shows the symbol *g4* is associated with the name *COUPLING* and that the value of this constraint function depends on *b3*. In physical terms, this means that there is a test to determine if two vibration frequencies are close together. Thus, the value of this constraint only depends on the values of all vibration frequencies.

The list of dependencies for constraints like *g4* (*COUPLING*) or behavior variables like *b3* (*MODES*) is simply a list of the design variables and behavior variables needed to evaluate that function. The meaning of dependencies in the case of a design variable such as *v1* (*LONGL*) may not be as obvious. However, the task of selecting a new value for a design variable such as the length of a longeron is influenced by the values of one or more constraint functions. If any constraint is violated then the optimizer will adjust the value of *v1*.

<b>symbol</b>	<b>name</b>	<b>depends_on</b>
<b>v1</b>	<b>LONGL</b>	<b>g1,g2,g3,g4,g10</b>
...	...	...
<b>b3</b>	<b>MODES</b>	<b>v1,v3,b1,b4</b>
...	...	...
<b>g4</b>	<b>COUPLING</b>	<b>b3</b>
...	...	...

## COFS I NETWORK GRAPH

This figure shows the network graph for the simplified COFS I problem. The planning and scheduling program identified three circuits in the network. These circuits correspond to three optimization subproblems:

- 1) determine the structural sizing for minimum weight,
- 2) determine dynamic excitation strategy for safe testing of the MFS, and
- 3) determine the best placement of the sensors for identification of mode shapes and frequencies.

This example is relatively simple. However, it illustrates a decomposition technique which can be applied to much more complicated experimental space system designs where the decomposition is not at all obvious.

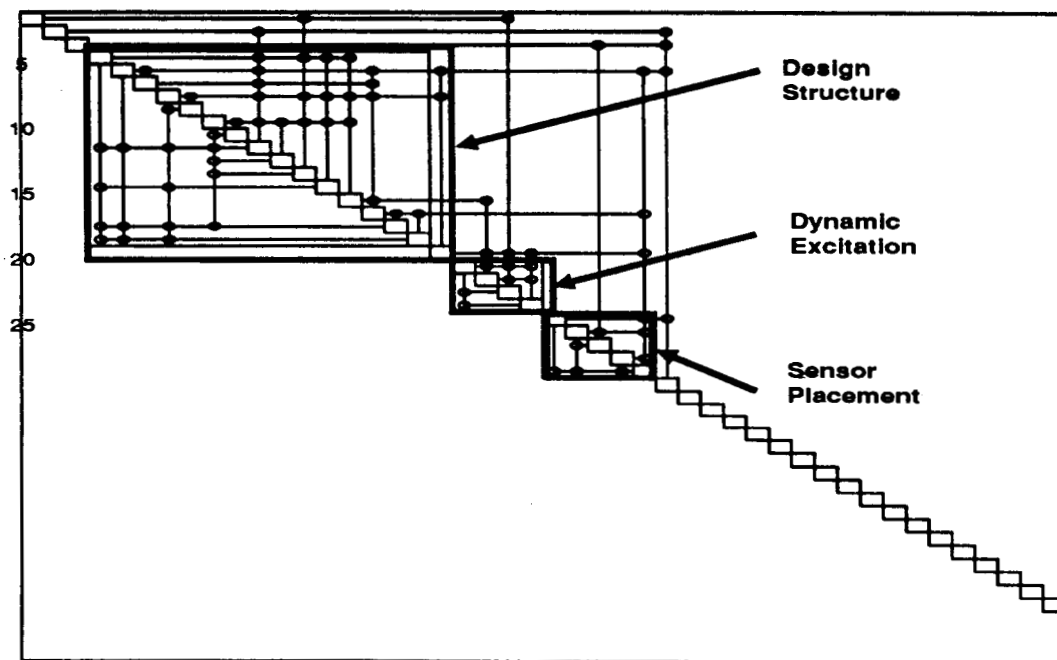

## UPDATE THE INPUT

The beauty of the planning and scheduling technique is evident when the design problem requires updating. The effect of new variables and constraints can be examined by simply adding them to the P&S input file.

For example, consider modifying the simple COFS I problem above to account for a number of actuators attached to the COFS I MFS. These actuators are used for dynamic excitation of the MFS.

The figure illustrates the addition of two design variables and one constraint to the P&S input file. The design variables control the number and location ( $L_A$ ), and the mass ( $M_A$ ) of actuators. One of these variables, the mass, is marked "no-input". This means that the mass of each actuator is initialized along with other system level variables and is not changed by any optimization subproblem. One constraint which evaluates the effectiveness of actuator placement (CONTROL) is also added.

Besides adding new lines to the input file, the designer must check whether any of the existing variables depend on those added. In the present example, the actuators have a significant mass and therefore they will effect the calculation of mode shapes and vibration frequencies. Notice that  $v_{11}$  ( $L_A$ ) and  $v_{12}$  ( $M_A$ ) have been added to the list of dependencies of behavior variable  $b_3$  (MODES).

<u>symbol</u>	<u>name</u>	<u>depends on</u>
$v_1$	LONGL	$g_1, g_2, g_3, g_4, g_{10}$
$v_{11}$	$L_A$	$g_{11}, g_{14}$
$v_{12}$	$M_A$	no-input
...	...	...
$b_3$	MODES	$v_1, v_3, b_1, b_4, v_{11}, v_{12}$
...	...	...
$g_4$	COUPLING	$b_3$
...	...	...
$g_{14}$	CONTROL	$v_{11}, v_{12}, b_3$

## MODIFIED NETWORK GRAPH

The network graph produced for the updated COFS I design problem is shown here. Notice that the P&S program identified just a single large circuit. This suggests that either the COFS I design must be solved as a single large optimization problem, or that the input file must be revised to permit decomposition.

Careful examination of the network graph reveals that there are just two feedback paths which prevent this network from decomposing the way the last one did. These feedback paths begin at the shaded box associated with the power requirement (POW\_REQ) constraints. At least one of these feedbacks can be easily removed. Notice that POW\_REQ is connected to both L\_A and L\_S tasks. This expresses the fact that the total power required by the system is influenced by the number of actuators and by the number of sensors. However, actuators require orders of magnitude of more power than do passive sensors. Thus, the design will not be greatly effected if both connections between POW\_REQ and L\_S tasks are removed. The other long feedback path expresses the correct assumption that the location of actuators is an important design variable in both the structures subproblem and in the dynamic excitation subproblem. One solution is to let the structures subproblem decide the value of this variable and force the dynamics subproblem to adjust other variables to compensate.

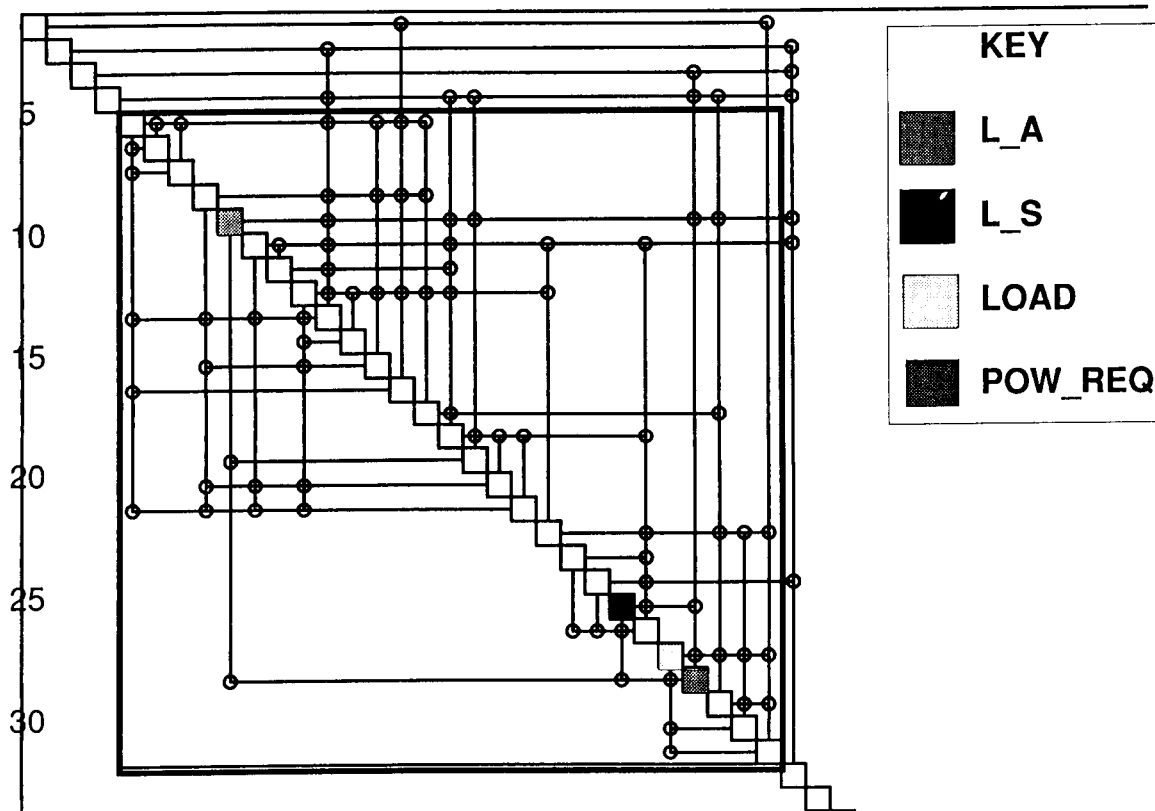

## FINAL COFS I NETWORK

By gradually refining the P&S input and by adding design variables and constraints to represent the design of a control system, a final network chart was produced. This network has 6 major circuits: actuator placement, sensor placement, structures and materials design, dynamic excitation specification and a two step controls design. These are identified on the figure.

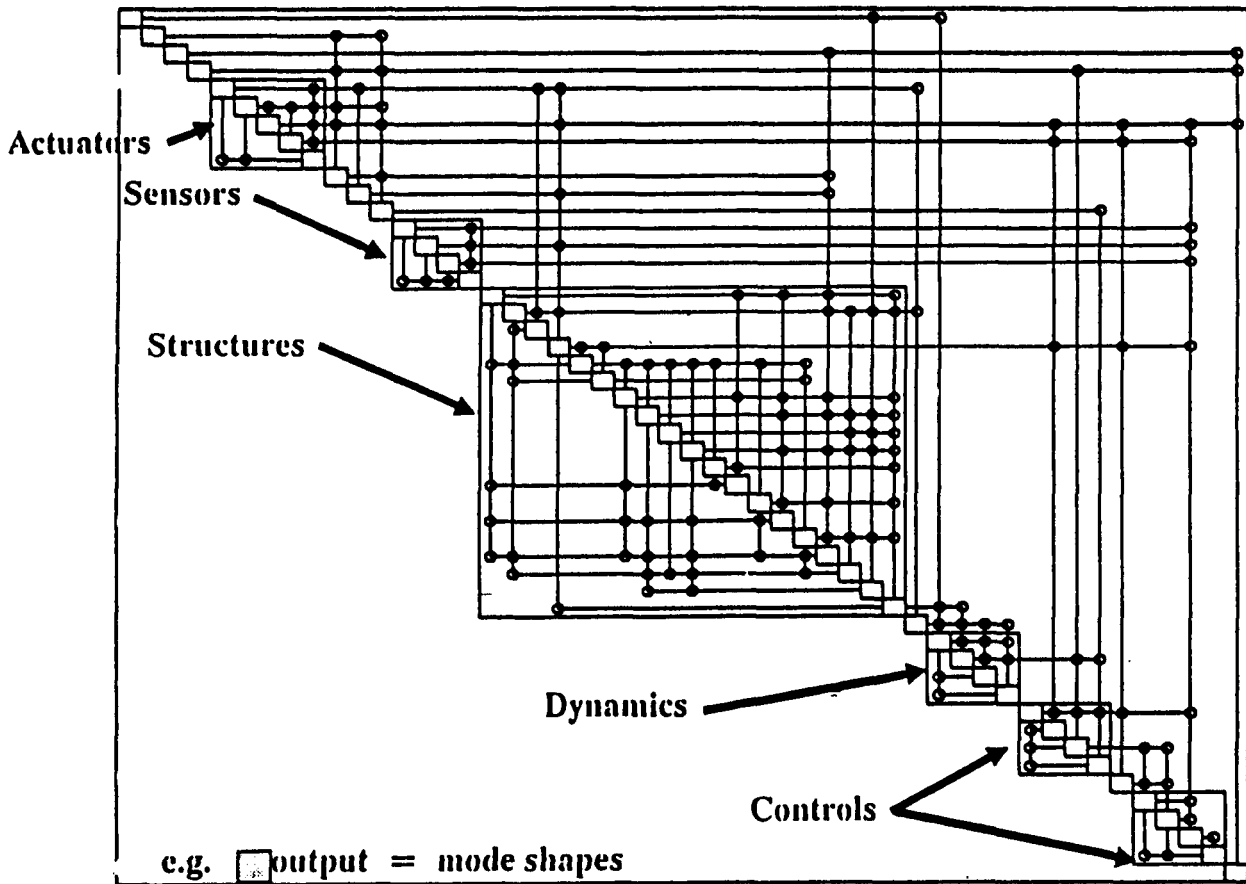



## COFS I MULTI-OBJECTIVE OPTIMIZATION PROBLEM

The multi-objective optimization for designing the COFS I MFS is defined by the network graph on the preceding page. The graph indicates which analysis steps must be performed in what order and identifies the flow of data from one step to another. The actual integration of computer codes will be much easier given the wealth of information contained in the P&S network graph.

The plan which emerges for solving the COFS I design problem is summarized by this flow chart. First, system level variables are initialized. These include the mass of an actuator, the target weight of the system, the power provided to the system and the maximum buckling load allowed for any truss element. Next, actuators and sensors are located along the length of the MFS. This can be accomplished manually or using a knowledge-based system similar to that of reference 14. This is followed by a standard optimization to size the structural elements for minimum weight and another optimization to prescribe safe amounts of dynamic excitation. The final step is to design the control algorithm. At the end of the process, the system design is evaluated. If the design is acceptable and no further improvement is likely, then the process terminates. Otherwise, the system level variables can be adjusted and the process repeated. Methods for adjusting the system level variables are explained in reference 15 which contains several options for calculating the sensitivity of the subproblem outputs to changes in the values of the system level variables.

### COFS I SYSTEM DESIGN

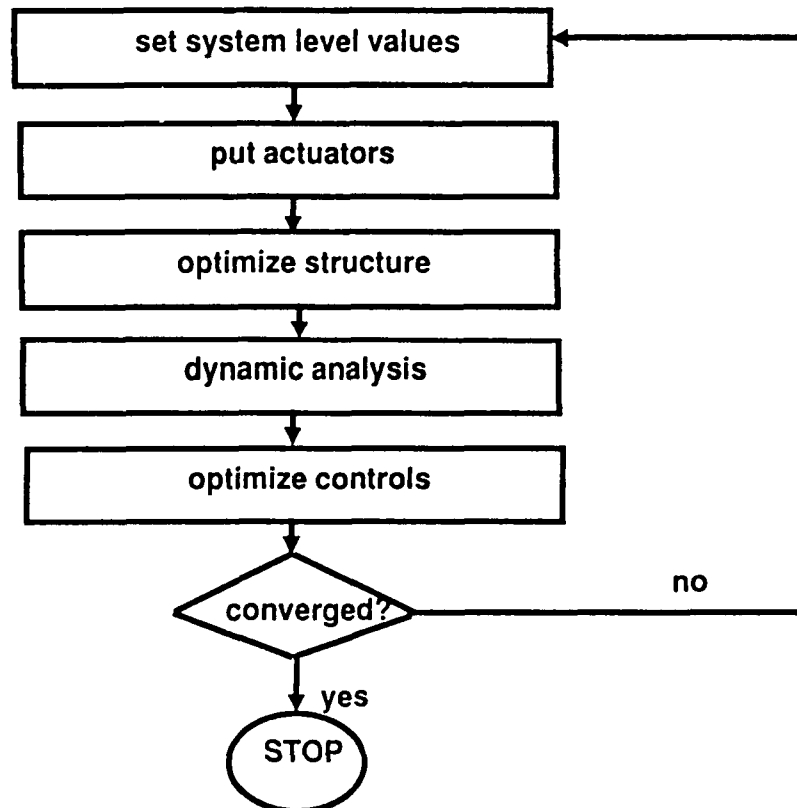

## CRITIQUE OF PLANNING AND SCHEDULING

One purpose of the present study is to evaluate the usefulness of automatic planning and scheduling as a tool for decomposition of complicated systems design problems. By applying the technique to the COFS I design, it is seen that P&S is especially helpful in revealing the subtle interaction between disciplines so that the design problem can be decomposed into smaller subproblems. A second benefit of P&S is that it condenses a huge amount of information into a single chart. This chart is easy to store and to update as new information becomes available. More importantly, the network chart provides a "strawman" for experts from different disciplines to discuss.

On the other hand, planning and scheduling does require an investment of time to prepare and refine the inputs. This investment may not be justified for a rather simple problem or for a problem whose decomposition is well understood. Rather, planning and scheduling is proposed as a tool for systematically unraveling a new design problem where the interaction between disciplines is still hazy. As illustrated by the COFS I example, the process of decomposing a new design problem requires engineering judgment. The list of variables and constraints do not appear by magic. Identifying a reasonable set of independent design variables is by no means an easy task. However, this must be done eventually, and the planning and scheduling technique offers a systematic way to attack the problem early in the design cycle.

**Reveals Interaction between disciplines**

**Stores and updates Info in convenient form**

**Facilitates communication between experts**

**Calls for Initial Investment of time**

**Requires engineering judgment to complete the decomposition**

## REFERENCES

1. Sobieski, J. (compiler): Recent Experiences in Multidisciplinary Analysis and Optimization. NASA CR-2327, September 1984.
2. Grandhi, R. V. and Venkayya, V. B.: Structural Optimization with Frequency Constraints. AIAA Paper No. 87-0787, AIAA/ASME/ASCE/AHS 28th Structures, Structural Dynamics and Materials Conference, Monterey, CA, April 1987.
3. Walsh, J. L.: Optimization Procedure to Control the Coupling of Vibration Modes in Flexible Space Structures. AIAA Paper No. 87-0826, AIAA/ASME/ASCE/AHS 28th Structures, Structural Dynamics and Materials Conference, Monterey, CA, April 1987.
4. Barthelemy, J.-F. M.: Development of a Multilevel Optimization Approach to the Design of Modern Engineering Systems. NASA CR-17218, August 1983.
5. Padula, S. L. and Sobieszczanski-Sobieski, J.: A Computer Simulator for Development of Engineering System Design Methodologies. NASA TM-89109, February 1987.
6. Vanderplaats, G. N., Yang, Y. J. and Kim, D. S.: An Efficient Multilevel Optimization Method for Engineering Design. AIAA Paper No. 88-2226, AIAA/ASME/ASCE/AHS 29th Structures, Structural Dynamics and Materials Conference, Williamsburg, VA, April 1988.
7. Mistree, F., Marinopolous, S., Jackson, D. and Shupe, J.: The Design of Aircraft using the Decision Support Problem Technique. NASA CR-4134, April 1988.
8. Wright, R. L. (compiler): NASA/DOD Control/Structures Interaction Technology 1986. NASA CR-2447, November 1986.
9. Ryan, Robert S., and Scofield, Harold N. (editors): Structural Dynamics and Control Interaction of Flexible Structures. NASA CP-2467, April 1987.
10. Sobieszczanski-Sobieski, J.: A Linear Decomposition Method for Large Optimization Problems - A Blueprint for Development, NASA TM-83248, Feb. 1982.
11. Wrenn, G.A., and Dovi, A. R.: Multilevel/ Multidisciplinary Optimization Scheme for Sizing a Transport Aircraft Wing, AIAA Paper No. 87- 0714-CP, AIAA/ASME/ASCE/AHS 28th Structures, Structural Dynamics and Materials Conference, Monterey, CA, April 1987.
12. Bandler, John W. and Zhang, Qi-Jun: An Automatic Decomposition Approach to Optimization of Large Microwave Systems. IEEE Transactions on Microwave Theory and Techniques, Vol. MTT-35, December 1987, pp. 1231-1239.
13. Steward, D. V.: Systems Analysis and Management: Structure, Strategy and Design. Petrocelli Books, Inc., New York, NY, 1981.

14. Rogers, J. L., Feyock, S., and Sobieszczanski-Sobieski, J.: STRUTEX - A Prototype Knowledge-Based System for Initially Configuring a Structure to Support Point Loads in Two Dimensions. NASA TM-100613, April 1988.

15. Sobieszczanski-Sobieski, J.: On the Sensitivity of Complex, Internally Coupled Systems. AIAA Paper No. 88-2226, AIAA/ASME/ASCE/AHS 29th Structures, Structural Dynamics and Materials Conference, Williamsburg, VA, April 1988. (also available as NASA TM-100537)