

N89-25196

An Approximation Function for Frequency Constrained Structural Optimization

R. A. Canfield

**Flight Dynamics Laboratory
Air Force Wright Aeronautical Laboratories *
Wright-Patterson AFB, Ohio**

*** Now the Wright Research Development Center**

PRECEDING PAGE BLANK NOT FILMED

Introduction

The purpose of this study is to examine a function for approximating natural frequency constraints during structural optimization. The nonlinearity of frequencies has posed a barrier to constructing approximations for frequency constraints of high enough quality to facilitate efficient solutions. A new function to represent frequency constraints, called the Rayleigh Quotient Approximation (RQA), is presented. Its ability to represent the actual frequency constraint results in stable convergence with effectively no move limits.

The objective of the optimization problem is to minimize structural weight subject to some minimum (or maximum) allowable frequency and perhaps subject to other constraints such as stress, displacement, and gage size, as well. A reason for constraining natural frequencies during design might be to avoid potential resonant frequencies due to machinery or actuators on the structure. Another reason might be to satisfy requirements of an aircraft or spacecraft's control law. Whatever the structure supports may be sensitive to a frequency band that must be avoided. Any of these situations or others may require the designer to insure the satisfaction of frequency constraints. A further motivation for considering accurate approximations of natural frequencies is that they are fundamental to dynamic response constraints. Techniques for natural frequency constraints may have application to transient response and frequency response problems.

Problem

Minimize Weight of Structure

Subject to Constraints on Structural Response (Natural Frequencies)

For a Finite Element Model (Cross-Sectional Properties as Design Variables)

With a Given Geometric Configuration.

Obstacle

Highly Nonlinear Frequency Constraints

Difficult to Approximate

Solution

Better Approximation Using Modal Energies

“Best” Choice of Intermediate Design Variables

Engineers have long used the Taylor Series Approximation (TSA) as a tool to simplify problems. In 1974 Schmit and Farshi exploited the use of TSAs to form approximate problems to the actual design problem.¹ Since then much attention has been focused on finding the most appropriate intermediate design variables to use for the best TSA. Schmit and Miura originally championed the use of reciprocal variables.² Starnes and Haftka³ and Fleury and Braibant⁴ have shown that a hybrid constraint using mixed variables (*i.e.*, a combination of direct and reciprocal variables) yields a more conservative approximation. Woo generalized the concept in his Generalized Hybrid Constraint (GHC) Approximation where a variable exponent controls how conservative is the convex approximation.⁵ Fleury devised a means of selecting an “optimal” intermediate variable based on second order information.⁶ Vanderplaats and Salajegheh demonstrated improved quality for frequency constraint approximations in the element property space of frame elements when the optimization design variables are cross-sectional dimensions.⁷ All of these approaches have sought improvement through the “best” choice of intermediate variables. Yet all of them have used a Taylor series of some sort for the eigenvalue.

- **Taylor Series Approximation (TSA)—Reciprocal Variables**
 - Schmit & Farshi, 1974
 - Schmit & Miura, 1976
- **Hybrid Constraint—Mixed Variables**
 - Starnes & Haftka, 1979
 - Fleury & Braibant, 1984
- **Generalized Hybrid Constraint (GHC)**
 - Woo, 1986 (Frequencies)
- **Cross-Sectional Property Space for Frames**
 - Mills-Curran, Lust & Schmit, 1983
 - Vanderplaats & Salajegheh, 1988 (Frequencies)

Alternatives to Conventional TSA

The nonlinearity of frequencies is readily observed through the appearance of cross-sectional variables in both the numerator and denominator of Rayleigh's quotient. Venkayya has pointed out that in practical structures, the denominator (kinetic energy) is typically dominated by the non-structural mass.⁸ In this case, frequency eigenvalues are more nearly linear in the cross-sectional property (direct design variable) space. Based on this assumption some researchers have preferred a Taylor series constructed in the direct design variable space.⁷ On the other hand, Miura and Schmit presented results that were better in the reciprocal design space than in the direct design space.⁹ Nevertheless, their studies revealed that the eigenvalues are highly nonlinear in both direct and reciprocal design variable space, requiring strict move limits. As a result, they used a second order Taylor series. Although the second order approximation provided stable convergence without strict move limits, they reported the total computational time was "comparable with that required using first order approximations with move limits."

In 1987 Vanderplaats and Salajegheh demonstrated for stress constraints that using a Taylor series to approximate the internal loads, instead of the stresses themselves, could increase the rate of convergence and reduce the need for move limits.¹⁰ They observed that internal loads are a more fundamental quantity than stresses. Venkayya's approach in formulating the optimality conditions for frequency constraints^{8,11} suggests that for frequencies modal energies may be a more fundamental quantity than the eigenvalue. A frequency constraint might be better approximated by a separate Taylor series for the numerator and denominator in the Rayleigh quotient. In fact, the concept is similar to an alternative approximation proposed by Fox and Kapoor.¹²

- **Miura & Schmit, 1978**
 - **Frequencies are Highly Nonlinear**
 - **2nd Order TSA**
 - **Generous Move Limits Offset by Added Cost**
- **Vanderplaats, 1987**
 - **Approximate Internal Loads Instead of Stresses**
 - **Loads—More Fundamental Quantity**
- **Venkayya, 1983**
 - **Modal (Strain) Energy Resizing**
- **Rayleigh Quotient Approximation (RQA)**
 - **Separate TSA for Modal Energies**

Mathematical Statement of Problem.

The structural optimization problem is stated mathematically as minimizing an objective function, the weight, W , subject to constraints on response quantities, g , where \mathbf{x} is a vector of n design variables, x^l and x^u represent their lower and upper bounds, respectively, and g are the m inequality constraints. The design variables are linked to one or more of the p physical variables, represented by the vector, \mathbf{d} , through a transformation matrix, \mathbf{T} . In general the \mathbf{T} matrix may be fully populated; however, each row of \mathbf{T} is limited to only one non-zero element (so-called group linking) when reciprocal variable approximations are considered. In this case the summation in eq (4) is unnecessary. The examples below use rod and membrane elements exclusively. Their design variables are the cross-sectional properties: rod areas and membrane thicknesses.

Frequency constraints are formed using the eigenvalue, (square of the angular frequency, ω) normalized by its allowable value. The positive sign is used for upper bounds and the minus sign for lower bounds. Only lower bound frequency allowables, λ^l , are given in the following examples, since minimizing structural weight drives frequencies toward zero. Other constraints are also cast in the form of eq (3) using the positive sign and replacing the λ 's with the appropriate response quantity (Von Mises stress or displacement value).

Minimize Structural Weight

$$\min W(\mathbf{x}) \quad (1)$$

Subject to

$$g_j(\mathbf{x}) \leq 0; \quad j = 1, \dots, m \quad (2)$$
$$x_i^l \leq x_i \leq x_i^u; \quad i = 1, \dots, n$$

Frequency Constraint

$$g = \pm \left(\frac{\lambda}{\lambda_{allow}} - 1 \right) \quad (3)$$

Design Variable Linking

$$d_k = \sum_{i=1}^n T_{ki} x_i; \quad k = 1, \dots, p \quad (4)$$

Approximate Sub-Problem

An approximation to the actual optimization problem is constructed by approximating the constraints using a first order Taylor series. If the approximate problem is solved in the reciprocal design variable space (*i.e.*, $\beta=1/x$), then the approximate constraint function is given by eq (6).

The Method of Mixed Variables uses either a direct or reciprocal variable depending on the sign of the the constraint's derivative for each design variable. This creates a convex and more conservative approximation. As generalized by Woo, the equations for the GHC are given in eqs (7) where p is a real number and n is a positive integer. When $p=0$ and $n=1$ the GHC reduces to the Method of Mixed Variables.

The approximate sub-problem formed with eqs (5), (6), or (7) is solved by a nonlinear programming optimization algorithm. Appropriate move limits are employed to insure that the design remains in the vicinity of the point about which the Taylor series was made. The move limits are applied as side constraints, eq (2), if they are more restrictive than the minimum and maximum gage constraints which are otherwise used. Move limits are typically specified as a percentage of the current design variables. Alternatively, a move limit factor, f , determines the upper and lower bounds.

Direct TSA	$\bar{g}_j = g_{o_j} + \sum_{i=1}^n \frac{\partial g_j}{\partial x_i} (x_i - x_{o_i})$	(5)
-------------------	--	-----

Reciprocal TSA	$\bar{g}_j = g_{o_j} - \sum_{i=1}^n \frac{\partial g_j}{\partial x_i} x_{o_i}^2 \left(\frac{1}{x_i} - \frac{1}{x_{o_i}} \right)$	(6)
-----------------------	---	-----

Generalized Hybrid Constraint (GHC) Approximation

$\bar{g}_j = g_{o_j} + \sum_{i=1}^n \frac{\partial g_j}{\partial x_i} f_i(x_i)$	$r = \begin{cases} p & \text{if } \frac{\partial g_j}{\partial x_i} \geq 0 \\ p - n; & \text{if } \frac{\partial g_j}{\partial x_i} < 0 \end{cases}$	(7)
$f_i(x_i) = (x_i - x_{o_i}) \left(\frac{x_i}{x_{o_i}} \right)^r$		

Move Limits	$\frac{x_i}{f} \leq x_i \leq f x_i; \quad i = 1, \dots, n$	(8)
--------------------	--	-----

Rayleigh Quotient

The structural system's mass and stiffness matrices can be represented by eqs (10), where \mathbf{K}' and \mathbf{M}' are the sensitivity of the stiffness and mass, respectively, to all the elements controlled by the i th design variable. For rod and membrane elements the element stiffness and mass matrices are linear in the design variables, so that eqs (10) are exact. For frames the element matrices are functions of several dependent cross-sectional properties. If cross-sectional dimensions are used as design variables instead, eqs (10) are approximate. As Vanderplaats and Salajegheh point out, the cross-sectional dimensions are appropriate intermediate design properties for the constraint approximation even when designing for the cross-sectional dimensions directly.¹¹ The RQA below is entirely compatible with their approach of constructing constraint approximations in the cross-sectional property space.

The relationship of a natural frequency, ω , to its associated eigenvector, ϕ , and the system's stiffness and mass is expressed by Rayleigh's quotient, eq (9), where the modal strain energy, U , and the modal kinetic energy, T , are the sum of the strain and kinetic energies, respectively, from each of the elements. This is expressed for modal strain energy in eq (11) and for modal kinetic energy in eq (12). Eqs (13) defines the element energies where u_o is strain energy from undesigned elements, and t_o is the kinetic energy due to non-structural mass and undesigned elements. The gradient of a frequency constraint, used in eqs (5) or (6), is given by eq (14).

$$\lambda = \omega^2 = \frac{\phi^t \mathbf{K} \phi}{\phi^t \mathbf{M} \phi} = \frac{U}{T} \quad (9)$$

$$U = u_o + \sum_{i=1}^n u_i x_i \quad (11)$$

$$T = t_o + \sum_{i=1}^n t_i x_i \quad (12)$$

$$\mathbf{K} = \mathbf{K}_o + \sum_{i=1}^n \mathbf{K}'_i x_i \quad (10)$$

$$u_i = \phi^t \mathbf{K}'_i \phi \quad (13)$$

$$\mathbf{M} = \mathbf{M}_o + \sum_{i=1}^n \mathbf{M}'_i x_i$$

$$t_i = \phi^t \mathbf{M}'_i \phi$$

$$\frac{\partial \lambda}{\partial x_i} = \frac{u_i - \lambda t_i}{T} \quad (14)$$

Rayleigh Quotient Approximation (RQA)

Instead of using eqs (5) or (6), Taylor series approximations to the strain and kinetic energies can be used to construct the approximate constraint. In deriving eqs (15) and (16) the eigenvectors were assumed invariant with respect to changes in the design variables. In fact, Miura and Schmit recommend this assumption as a means of reducing the computational burden of calculating the second derivative of a frequency. The assumption is also implicit in Venkayya's derivation of a scaling factor for frequency constraints.¹³ The two approximations of eqs (15) and (16) are next combined to form a single approximate frequency constraint, eq (17).

The same issue of an appropriate intermediate design variable is as pertinent for eqs (15) and (16) as for constructing a Taylor series directly for the eigenvalue. Starnes and Haftka proposed that the sign of the constraint's derivative should determine the appropriate variable. A positive derivative indicates a direct variable approximation, a negative derivative signals a reciprocal variable approximation. Therefore a conservative approximation for a lower bound frequency constraint should employ reciprocal variables for the strain energy and direct variables for the kinetic energy. The reverse is true for an upper bound frequency constraint. For the former, more typical case eq (15) is replaced by eq (18).

For a lower bound frequency the approximate frequency's derivative is by eqs (19) and (20), where $\bar{\lambda} = \bar{U}/\bar{T}$. The sign of eq (19) can change as the design changes. This behavior is consistent with intuition which says that the frequency tends toward zero as the cross-sectional properties go to zero. This trait is not characteristic of TSAs to the eigenvalue in direct or reciprocal design space, nor for Woo's GHC.

Modal Strain Energy Approximation

$$\bar{U} = U_o + \sum_{i=1}^n u_i (x_i - x_{o_i}) \quad (15)$$

Modal Kinetic Energy Approximation

$$\bar{T} = T_o + \sum_{i=1}^n t_i (x_i - x_{o_i}) \quad (16)$$

Approximate Frequency Constraint

$$\bar{g} = 1 - \frac{\bar{U}}{\lambda' \bar{T}} \quad (17)$$

Reciprocal TSA to Modal Strain Energy

$$\bar{U} = U_o - \sum_{i=1}^n u_i x_{o_i} \left(\frac{x_{o_i}}{x_i} - 1 \right) \quad (18)$$

RQA gradient

$$\frac{\partial \bar{\lambda}}{\partial x_i} = \frac{\left(\frac{x_{o_i}}{x_i} \right)^2 u_i - \lambda' t_i}{\bar{T}} \quad (19) \quad \frac{\partial \bar{g}}{\partial x_i} = \frac{-1}{\lambda'} \frac{\partial \bar{\lambda}}{\partial x_i} \quad (20)$$

Special Case of High Non-Structural Mass

Structural designs with high non-structural mass constitute a limiting case for the RQA. Venkayya introduced modal mass ratios to characterize the degree of structural versus non-structural mass. If the mass matrix is considered as the sum of a structural mass matrix, \mathbf{M}_s , and a constant (non-structural) mass matrix, \mathbf{M}_c , then the modal mass ratios are defined in eqs (21) and (22). By definition $\eta + \gamma = 1$. In the limit as non-structural mass becomes dominant, $\gamma \rightarrow 1$ and $\eta \rightarrow 0$, the modal kinetic energy can be considered constant with respect to design changes, and the second term in the derivatives of the eigenvalue in eqs (14) and (19) can be neglected. In this case the RQA reduces to a TSA—either the reciprocal or direct variety depending on which design space was used to approximate the modal strain energy. Starnes and Haftka's hybrid constraint reduces the reciprocal TSA in this case, as well. The same reasoning for choosing the reciprocal design space indicates that it would be more successful than the direct design space for conventional TSAs when optimizing structures with a low modal structural mass ratio. A graphical illustration of this point is seen in a later figure for the beam problem.

COMPUTATIONAL CONSIDERATIONS.

The only computational penalty for using RQA is that the optimizer has to deal with explicit nonlinear instead of linear constraints. The sensitivity analysis is the same except that two gradients must be stored for each frequency constraint instead of one. Additional "bookkeeping" is required to distinguish a frequency constraint from other types in order to apply the RQA. Otherwise the method involves no more complexity than a conventional TSA.

Modal Mass Ratios

$$\text{Structural } \eta = \frac{\phi^t \mathbf{M}_s \phi}{\phi^t \mathbf{M} \phi} \quad (21)$$

$$\text{Non-Structural } \gamma = \frac{\phi^t \mathbf{M}_c \phi}{\phi^t \mathbf{M} \phi} \quad (22)$$

RQA reduces to TSA in λ as $\gamma \rightarrow 1$

Computational Considerations

- **Explicit Non-Linear Constraint**
- **1st Order Information only**
- **2 gradients per Frequency Constraint**
- **Gradient of RQA can Change Sign**

Three Bar Truss

A simple three bar truss is used to illustrate the differences among approximation techniques. A 10 lb point mass is at the free node. All three bars have an elastic modulus of 10×10^6 psi, density of 0.1 lb/in^3 , initial areas of 5.0 in^2 , and minimum sizes of 0.001 in^2 . The fundamental frequency is constrained to be at least 1300 Hz. As in the remaining examples, TSAs are made in both direct and reciprocal design space. For RQA the kinetic energy Taylor series is always made in the direct design space. In reference to RQA “direct” and “reciprocal” distinguish the design space used for approximating the strain energy. Effectively no move limits were imposed, *i.e.*, $f=10,000$ in eq (8). Due to symmetry the two mode shapes for this system are always the same: one horizontal and one vertical. Since a constant mode shape was the only assumption made in deriving the RQA, when strain energy is found with direct variables, RQA calculates the exact frequency and finds the optimum in a single iteration. Because signs of the constraint’s derivatives are not all the same, a TSA in either space creates an infeasible design that is corrected the next iteration. RQA with strain energy in reciprocal space is conservative, producing only feasible designs. The initial design has $\gamma=0.51$ and the final design, $\gamma=0.65$.

The design can be controlled by a single variable by recognizing two simplifications: symmetry forces the two diagonal bars to have the same area, and because the vertical bar contributes no strain energy to the fundamental mode, it goes to minimum. The constraint functions are plotted in as a function of the single variable controlling the two diagonal bars. Using the direct RQA, the optimum area of 3.736 in^2 for these two bars can be calculated by hand. The conservative nature of approximating strain energy in the reciprocal space is also evident. In general the reciprocal RQA will compensate for changes in the eigenvector; however, in this instance with an invariant mode shape, it is overly conservative.

- A Direct RQA
- B Reciprocal RQA
- C Direct TSA
- D Reciprocal TSA

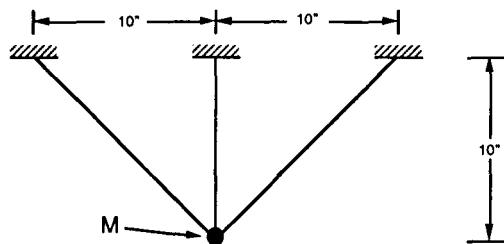

	A	B	C	D
1	19.14	19.14	19.14	19.14
2	10.57	11.50	10.36	0.015
3	10.57	10.67	10.56	141.3
4		10.57	10.56	24.02
5		10.57		13.30
6				10.87
7				10.57

Table 1: Iteration History (Weight)—3 DV

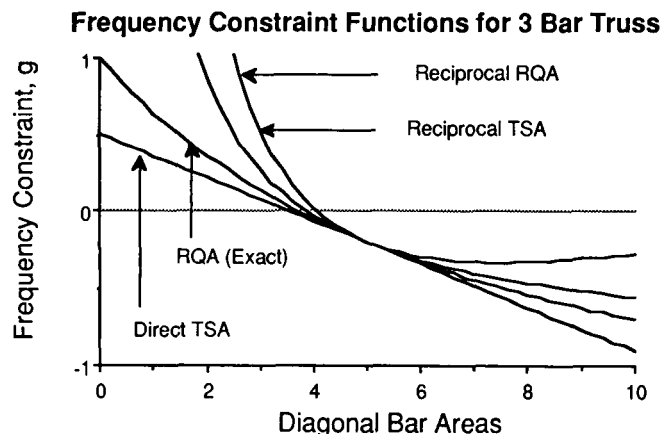

Cantilever Beam

The cantilever beam, originally used by Turner,¹⁴ is modelled using rod and shear panel elements. It is symmetric about the mid-plane and supports three non-structural masses, each 30 lb. Chord areas (A_1, A_2, A_3) and web thicknesses (t_1, t_2, t_3) are optimized for minimum weight subject to a minimum fundamental frequency of 20 Hz. No other constraints are applied except minimum gages of $A_i=0.01 \text{ in}^2$ and $t_i=0.001 \text{ in}$. Initial values are $A_i=1.0 \text{ in}^2$ and $t_i=0.2 \text{ in}$. Young's Modulus is $10.3 \times 10^6 \text{ psi}$, Poisson's ratio is 0.3, and the density is 0.1 lb/in^3 .

Designs were feasible at every iteration using RQA without move limits ($f=100$) and the rate of convergence was faster than for Woo's results.

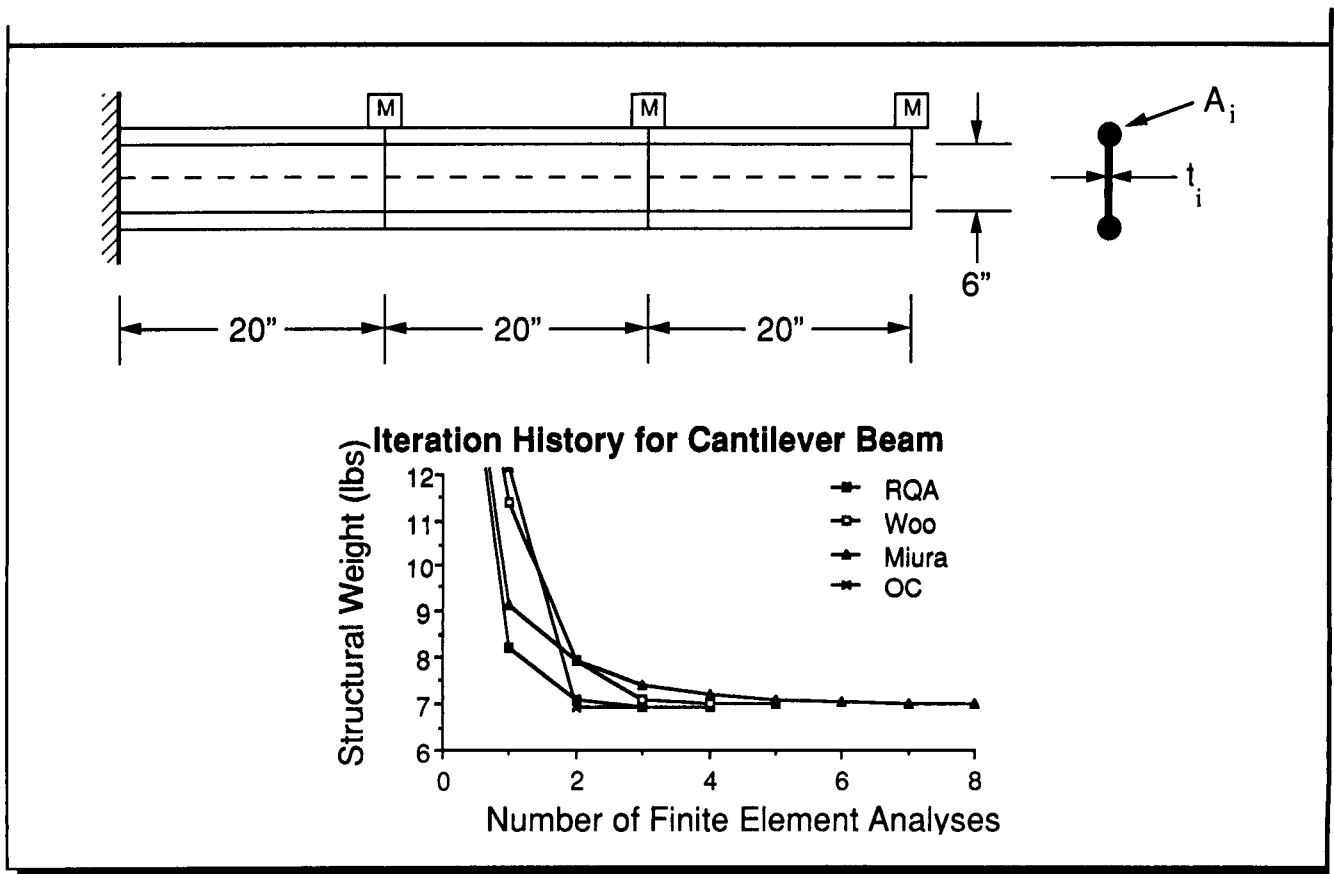

Cantilever Beam Results

The final design is similar to those obtained by Turner,¹⁴ Miura,⁹ and Woo;⁵ however, the weight is slightly higher than for the latter two—entirely as a result of modelling and analysis differences. When Miura and Woo's final designs were analyzed in the small optimization program used for this paper, as well as in ASTROS*, the frequency was 19.3 *hz*. When the lower bound frequency was set to this value, the final designs were more nearly the same.

In order to examine the design space, the number of variables was reduced at a point near the optimum design. One design variable was linked to all the rod areas and one linked to the web thicknesses in the ratios given in Table 3. Contours of the resulting constraint surfaces are plotted for the approximate functions along with the actual constraint surface. The failure of the direct TSA reported by Miura and Woo is evident in the poor quality of the approximating constraint surface to the actual highly nonlinear surface. In fact since the direct TSA constitutes a linear programming problem, the optimizer always moves to a vertex in the design space, choosing to maximize the most effective variable while minimizing the rest. In the absence of severely restrictive move limits or other constraints to cut off the design space, a feasible design is never achieved. Also, because the final modal non-structural mass ratio is 0.98, the RQA closely follows the reciprocal TSA. Since the sign of both constraint derivatives is negative, Woo's GHC with $p=0$ and $n=1$ (equivalent to Fleury's Method of Mixed Variables) would be identical to the Reciprocal TSA.

	A.1	A.2	A.3	t.1	t.2	t.3	Weight	Frequency*
Turner**	0.91	0.485	0.14	0.037	0.034	0.023	7.27	19.8
Miura	0.871	0.441	0.108	0.044	0.041	0.026	7.00	19.3
Woo	0.866	0.442	0.109	0.046	0.041	0.025	7.01	19.3
RQA	0.875	0.466	0.129	0.035	0.031	0.020	6.92	19.3
RQA	0.955	0.484	0.140	0.038	0.034	0.022	7.44	20.0

*Frequencies calculated using CROD and CSHEAR elements (lumped mass) in ASTROS.

**Areas for Turner's design are the average for a linearly tapered rod.

Table 2: Cantilever Beam Final Designs

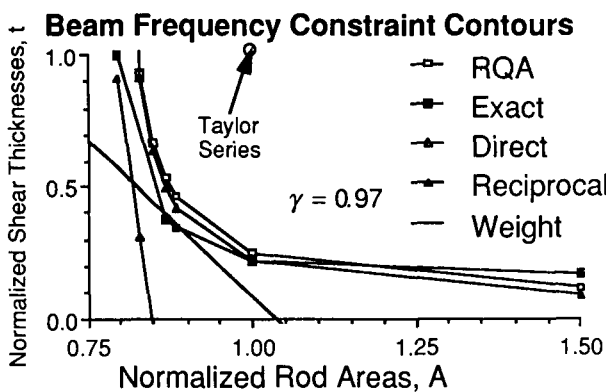

A.1	A.2	A.3
1.0	0.56	0.125
t.1	t.2	t.3
0.10	0.08	0.06

Table 3: Cantilever Beam Intermediate Design

*Automated Structural Optimization System

Cantilever Beam Single Design Variable Constraint Functions

Consider next the constraint surfaces as a function of a single variable, the tip rod's area (A_3). The first plot shows a cut along the A_3 axis through the six-dimensional design space for the constraint functions near the same nearly optimum design point ($\gamma=0.97$). It reflects the same comments mentioned above. The second plot shows the same functions constructed at the initial design point ($\gamma=0.88$) where the constraint derivative with respect to A_3 is positive instead of negative. Here the difference between the RQA and other approximations stands out. The RQA closely follows the actual constraint surface. Its derivative can change sign to match the curvature of the actual surface, whereas the TSA's derivative cannot change sign. In fact, the TSA's derivative is constant in the design space in which it was constructed. The advantage of Woo's GHC is that, based on the constraint's sign, it chooses the direct TSA surface which is more conservative than the reciprocal TSA surface in this case. Neither TSA, however, represents the actual constraint surface well.

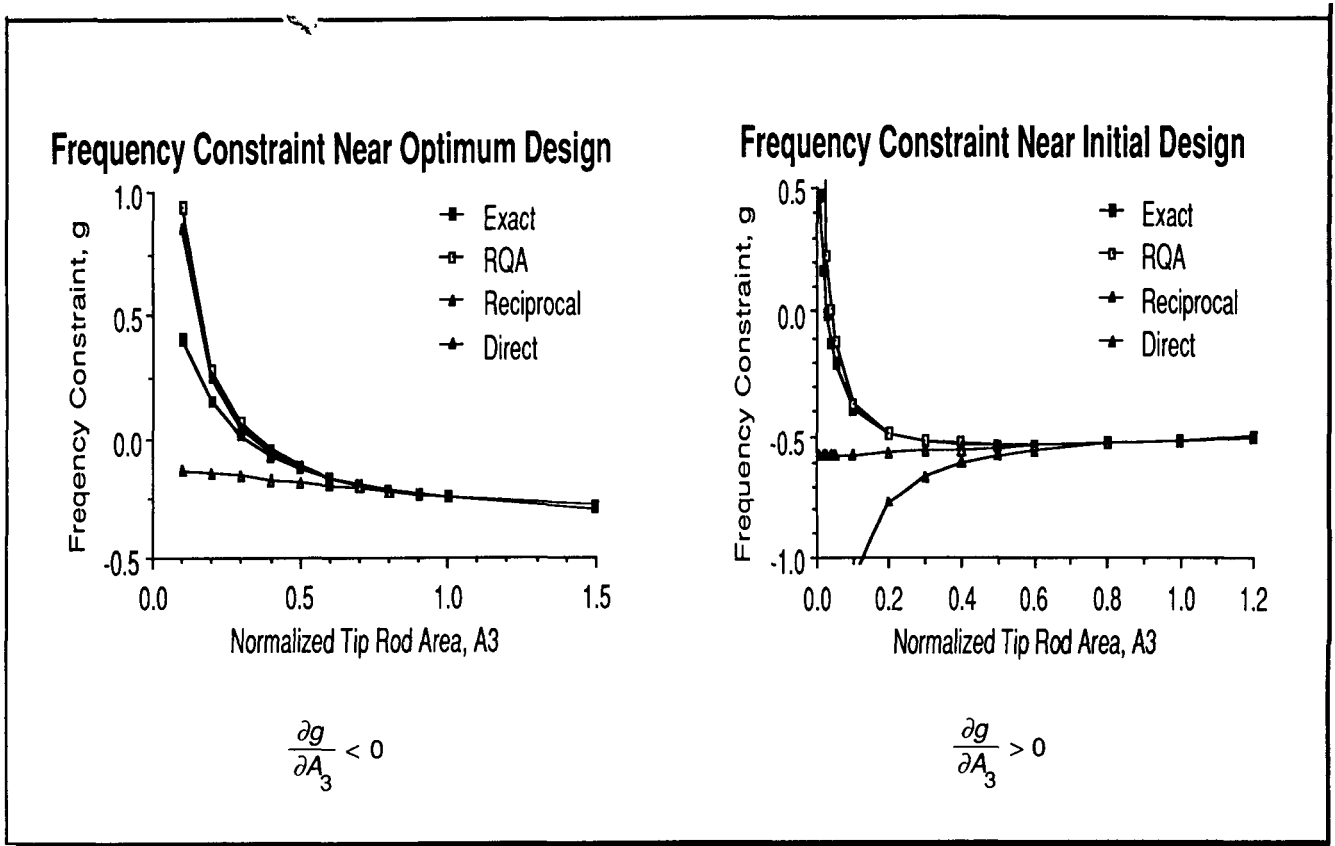

ACOSS

The Active Control Of Space Structures (ACOSS) model II was developed by the Charles Stark Draper Laboratory.¹⁵ The structure consists of two subsystems: (1) the optical support structure and (2) the equipment section. The two are connected by springs at three points to allow vibration isolation. In this problem the equipment section at the base was disregarded and only the optical support structure fixed at the three connection points was considered. The finite element model for this modified ACOSS II has 33 nodes (90 degrees of freedom), 18 concentrated masses, and 113 rod elements made of graphite epoxy with Young's Modulus of 18.5×10^6 psi, Weight Density of 0.055 lb/in^3 , and initial areas of 10.0 in^2 for the truss members.

ACOSS Figures

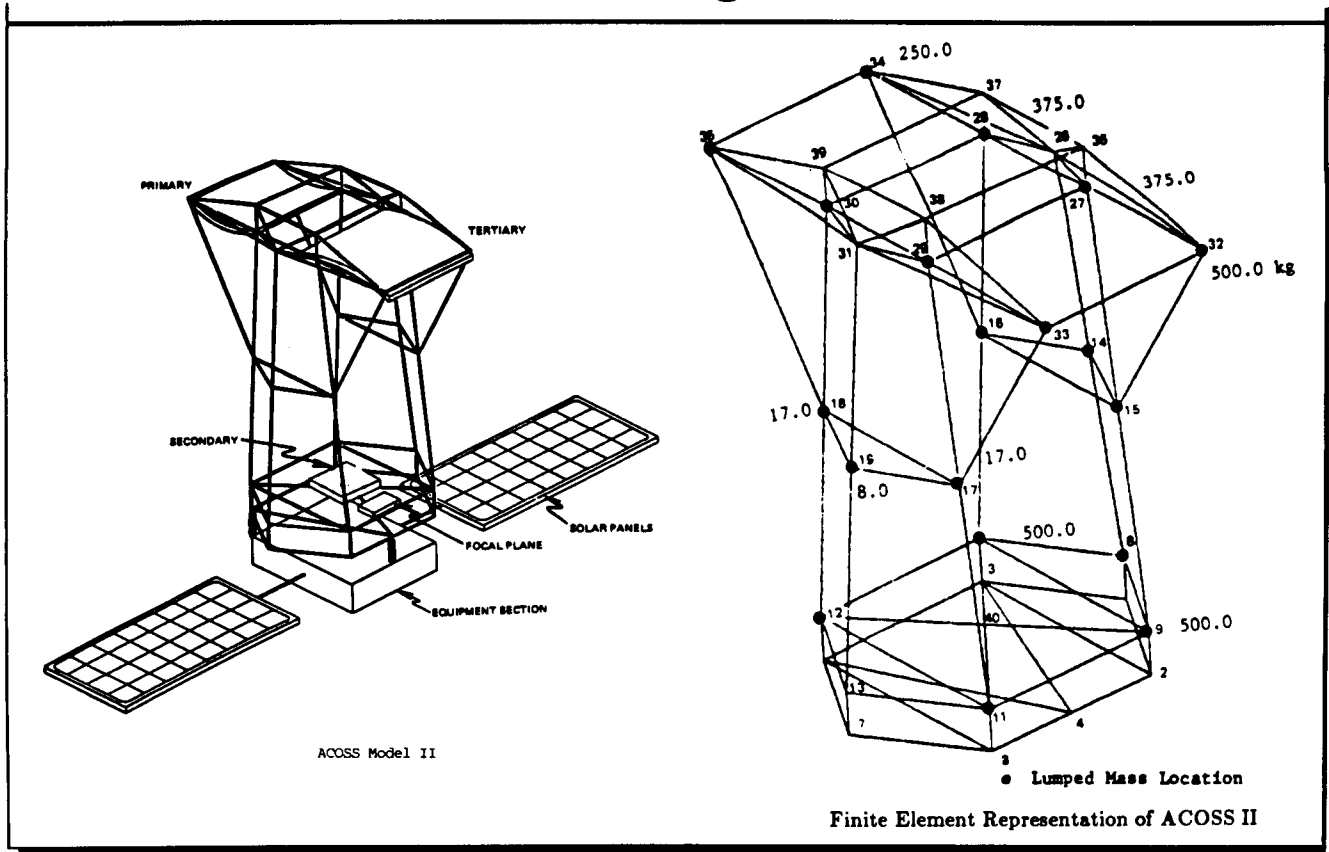

ACOSS Results

The structural weight was minimized using all 113 elements as design variables subject to a lower bound frequency of 2.0 *hz* and minimum sizes of 0.1 *in*². The results show that RQA achieves a final design significantly better than TSA or the Optimality Criteria (OC) method.¹² A reciprocal TSA fails to converge to a feasible design even with $f=1.5$. The results in the figure are for $f=1.5$ at iteration one, exponentially reduced at each iteration to a lower limit of $f=1.2$. Still, the constraint is violated ($g>0.1\%$) in the first 11 iterations and violated by more than 1% in the first 5 iterations. For RQA the move limit scale factor ($f=2$) prevented a feasible design until after the second iteration, after which all subsequent designs were feasible. With less restrictive move limits ($f=100$ initially, exponentially reduced to $f=2$) RQA's first iteration was feasible; however, some subsequent intermediate designs were violated by 1–3%. RQA still has an infeasible design after increasing the weight in the first iteration and then subsequent designs are feasible. Initially $\gamma=0.42$ and at the final design $\gamma=0.86$, showing why a reciprocal TSA eventually becomes more conservative, producing a feasible final design.

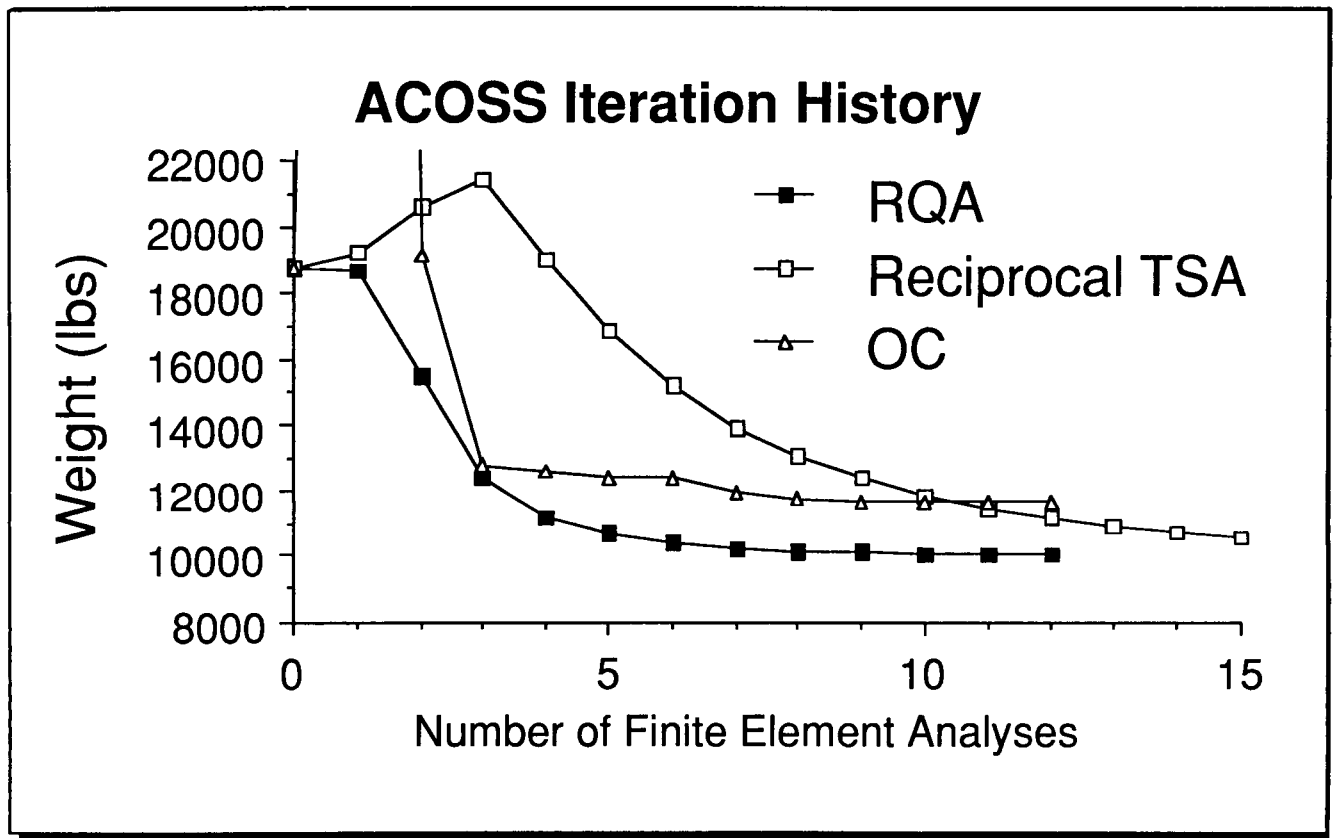

Conclusions.

A new function for approximating the frequency constraints during the solution of a structural optimization's approximate subproblem was developed. The motivation for this Rayleigh Quotient Approximation was to approximate some quantity more fundamental than the eigenvalue itself in order to improve the quality of the constraint approximation. Constructing approximations to the modal strain and kinetic energies independently results in more accurate constraint evaluation without any additional computational burden. The numerical examples demonstrate that the RQA is more conservative than other approximations and permits stable convergence without stringent move limits. Future work should be directed toward examining multiple frequency constraint problems, more direct comparisons to Woo's GHC approach, and application to space frames.

- **RQA—Frequency Constraint Approximation Function**
 - **Separate TSAs for Modal Energies**
- **Higher Quality Approximation**
 - **Generous Move Limits**
 - **Quick Convergence to Feasible Design (Conservative)**
 - **Derivative Changes Sign to Follow Constraint Surface**
- **No User Supplied Parameters**
- **Future Work**
 - **Multiple Frequencies**
 - **Frames**
 - **More Comparisons to GHC (Mixed Variables)**

References

1. Schmit, L.A.; and Farshi, B.: Some Approximation Concepts for Structural Synthesis. *AIAA J.*, vol. 2, no. 5, 1974, pp. 692–699.
2. Schmit, L.A.; and Miura, H.: Approximation Concepts for Efficient Structural Synthesis, NASA CR–2552, 1976.
3. Starnes, J.H.; and Haftka, R.T.: Preliminary Design of Composite Wings for Buckling, Strength, and Displacement Constraints, *J. Aircraft*, vol. 16, no. 8, 1979, pp. 564–570.
4. Fleury, C.; and Braibant, V.: Structural Optimization—A New Dual Method Using Mixed Variables, *I.J. Num. Methods in Engr.*, vol. 23, pp. 409–428, 1986.
5. Woo, T.H.; Space Frame Optimization Subject to Frequency Constraints, Proc. 27th AIAA/ASME/ASCE/AHS Structures, Structural Dynamics, and Materials Conference, San Antonio, TX, May 19–21, 1986, pp. 103–115.
6. Fleury, C.: Efficient Approximation Concepts Using Second Order Information, Proc. 29th AIAA/ASME/ASCE/AHS Structures, Structural Dynamics, and Materials Conference, Williamsburg, VA, April 18–20, 1988, pp. 1685–1695.
7. Vanderplaats, G.N.; and Salajegheh, E.: An Efficient Approximation Technique for Frequency Constraints in Frame Optimization, *I.J. Num. Methods*, vol. 26, 1988, pp. 1057–1069.
8. Venkayya, V.B.; and Tischler, V.A.: Optimization of Structures with Frequency Constraints, *Comp. Methods Nonlinear Solids and Structural. Mech.*, ASME, AMD–54, 1983, pp. 239–259.
9. Miura, H.; and Schmit, L.A.: Second Order Approximation of Natural Frequency Constraints in Structural Synthesis, *I.J. Num. Methods in Engr.*, vol. 13, 1978, pp. 337–351.
10. Vanderplaats, G.N.; and Salajegheh, E.: A New Approximation Method for Stress Constraints in Structural Synthesis, Proc. 28th AIAA/ASME/ASCE/AHS Structures, Structural Dynamics, and Materials Conference, Monterey, CA, April 6–8, 1987, pp. 314–321.
11. Grandhi, R.V.; and Venkayya, V.B.: Structural Optimization with Frequency Constraints, 28th AIAA/ASME/ASCE/AHS Structures, Structural Dynamics, and Materials Conference, Monterey, CA, April 6–8, 1987, pp. 32–329.
12. Fox, R.L.; and Kapoor, M.P.: Rates of Change of Eigenvalues and Eigenvectors, *AIAA J.*, vol. 6, no. 12, 1968, pp. 2426–2429.
13. Canfield, R.A.; Grandhi, R.V.; and Venkayya, V.B.: Structural Optimization with Stiffness and Frequency Constraints, *Mechanics of Structures and Machines*, vol. 17, no. 1, 1989.
14. Turner, M.J.: Design of Minimum Mass Structures with Specified Natural Frequencies, *AIAA J.*, vol. 5, no. 3, March, 1967, pp. 406–412.
15. Handerson, T.: Active Control Of Space Structures (ACOSS) Model 2, Report C–5437, Charles Stark Draper Laboratory, Inc, Sept, 1981.