

N89-25211

**OPTIMIZING CONCEPTUAL AIRCRAFT DESIGNS
FOR MINIMUM LIFE CYCLE COST**

**Vicki S. Johnson
NASA Langley Research Center
Hampton, Virginia**

IMPORTANCE OF COST IN CONCEPTUAL DESIGN

Engineers have traditionally designed systems that maximize performance while minimizing size and weight. Current practice in the conceptual design process tends toward approximation of minimum cost by either using minimum takeoff gross weight, empty weight, or fuel burned. It is generally accepted that between 70 and 80 percent of the life cycle cost of a configuration is locked in during the concept stage of development when very little actual money has been spent, as shown for military aircraft in figure 1 (taken from ref. 1). Reference 2 illustrates the same trend for commercial aircraft programs at the Boeing Company. During the early stages of development, commitments are made to increased performance over existing systems, thus implying the need to consider new technologies.

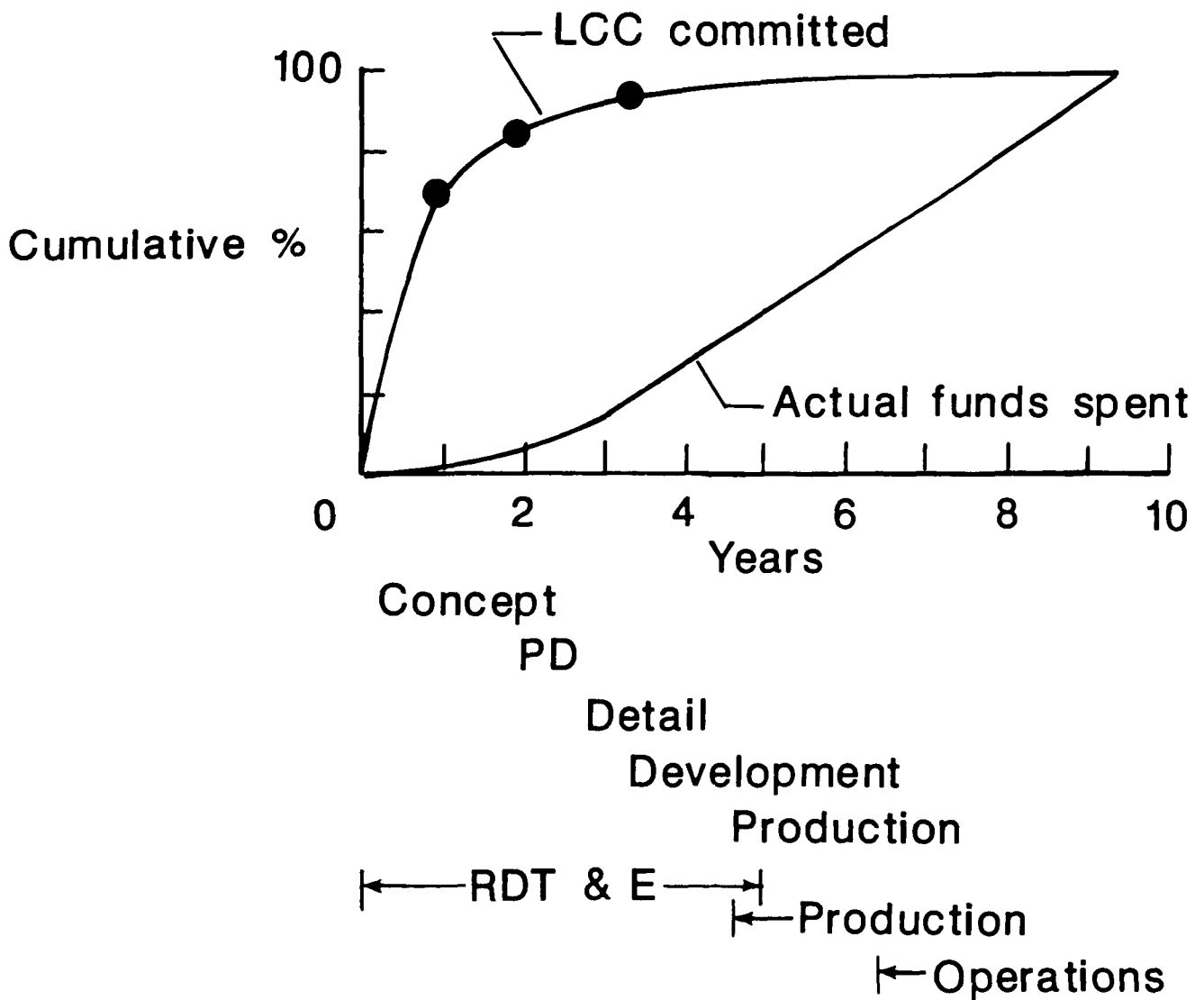
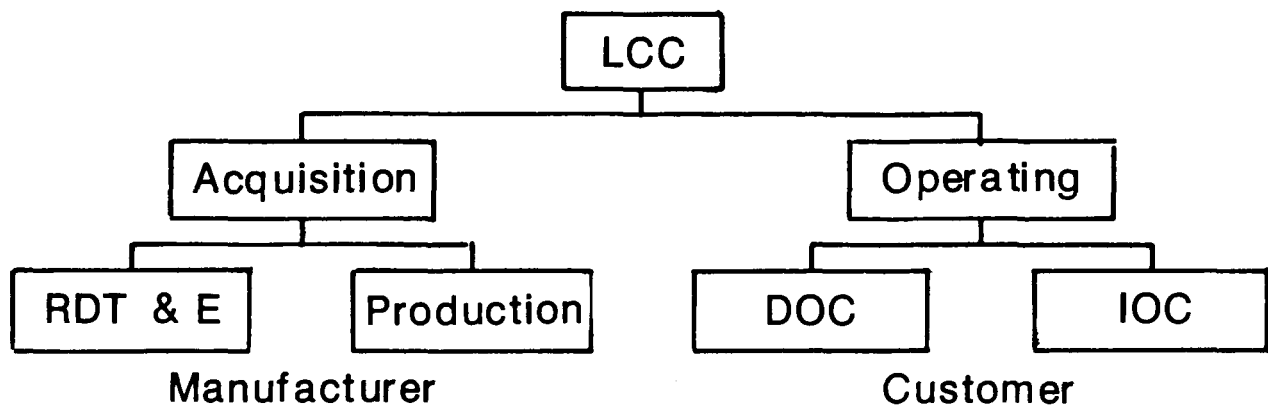

Figure 1

LIFE CYCLE COST

The life cycle cost (LCC) of an aircraft is the total cost associated with that aircraft from initial inception through the aircraft leaving service at the end of its life. The two major components of LCC are acquisition and operating costs (fig. 2). Acquisition cost is composed of research, development, testing and evaluation (RDT&E), and production costs, and is primarily associated with the manufacturer. Operating cost includes DOC (direct operating cost) and IOC (indirect operating cost) and is primarily associated with the customer or airline. Using LCC in the conceptual design process emphasizes the importance of balancing the design between potentially conflicting parameters. For example, low acquisition cost may be associated with low technology level and high operating cost. The prevailing economic conditions strongly influence how much technology can be included on the aircraft.



Considering LCC in the conceptual design process emphasizes the importance of balancing the design between potentially conflicting parameters

Figure 2

LCC CONCEPTUAL DESIGN SYSTEM

Figure 3 shows a schematic diagram of the system developed to include LCC in the conceptual design process. The system includes an existing conceptual design and analysis code called FLOPS (Flight Optimization System) and a LCC model developed for this effort. Input to the system includes a baseline mission, aircraft (geometry and propulsion data minimally), and economic assumptions. FLOPS and the LCC model will be described in more detail in the following two figures.

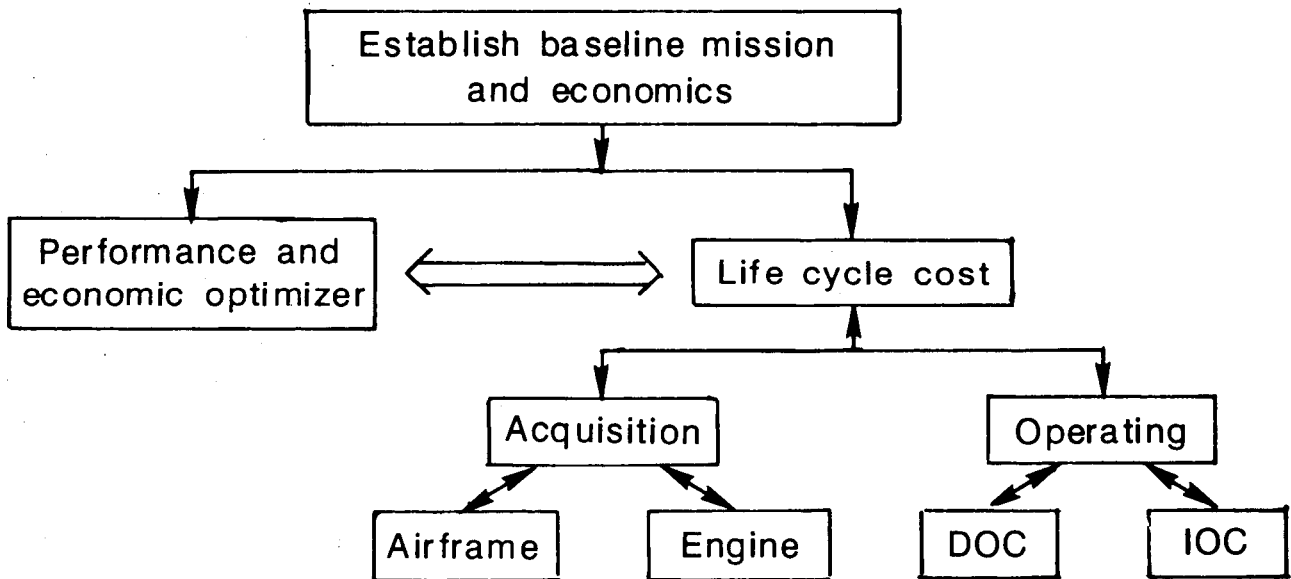

Figure 3

FLOPS CONCEPTUAL DESIGN PROGRAM

The major features of FLOPS (ref. 3) are discussed in figure 4. FLOPS is a multidisciplinary system of computer programs for conceptual and preliminary design and evaluation of advanced aircraft concepts. It originally consisted of four primary modules: weights, aerodynamics, mission performance, and takeoff and landing. FLOPS may be used to analyze a point design, parametrically vary certain design variables, or optimize a configuration with respect to these design variables using nonlinear programming techniques. The available design variables are wing area, wing sweep, wing aspect ratio, wing taper ratio, wing thickness-chord ratio, gross weight, thrust (size of engine), cruise Mach number, and maximum cruise altitude. Additionally, complexity factors can be used to account for advanced technologies in weights, aerodynamics, and propulsion. Previously, optimization could be done for minimum gross weight, minimum fuel burned, maximum range, or some combination of these. The addition of the LCC module to this conceptual design system allows cost to become an additional optimization parameter, making it possible to specify life cycle cost, acquisition cost, direct operating cost, total operating cost, or return on investment as the parameter to be optimized.

- ORIGINAL MODULES FOR WEIGHTS, AERODYNAMICS, MISSION PERFORMANCE, AND TAKEOFF AND LANDING
- ANALYZE DESIGN, VARY DESIGN PARAMETERS, OR OPTIMIZE CONFIGURATION
- DESIGN VARIABLES ARE S , Λ , AR , λ , T/C , T_{GW} , T_{MAX} , M_{CR} AND H_{CR}
- TECHNOLOGY LEVEL VARIATION THROUGH COMPLEXITY FACTORS
- OPTIMIZE FOR MINIMUM GROSS WEIGHT, MINIMUM FUEL BURNED, MAXIMUM RANGE, OR SOME COMBINATION

Figure 4

LCC MODEL

The LCC model is composed of elements to calculate RDT&E cost, production costs, DOC and IOC. Existing cost models (fig. 5) were selected for each of these elements based on their applicability to subsonic commercial aircraft and their connection to the conceptual design phase of development. These models are described in greater detail in reference 4.

The airframe acquisition cost is computed from the RDT&E cost model of reference 5 and the SAI (Scientific Associates, Inc.) production cost model of reference 6. The RDT&E model uses weight, speed and production quantity; weight and quantity are the primary cost drivers in the SAI model but weight is dependent on conceptual design type variables. A Rand model (ref. 7) is used to predict engine acquisition cost. The model uses engine size, weight, and performance parameters as variables affecting cost. The model is for military turbojet and turbofan engines; it was modified to produce results correct for commercial engines. The operating cost models include the American Airlines DOC model (ref. 8) and the Lockheed-Georgia IOC model (ref. 9). The DOC model is a modification of the ATA-67 model (ref. 10) which accounts for more of the conceptual design variables and includes more recent real world experience. The IOC model is the industry standard and includes some conceptual design variables.

ACQUISITION COST

AIRFRAME

RDT&E - EIDE MODEL (WEIGHT, SPEED, QUANTITY)

PRODUCTION - SAI MODEL (WEIGHT, QUANTITY)

- WEIGHT FUNCTION OF CONCEPTUAL DESIGN VEHICLES

ENGINE - MODIFIED RAND MODEL

- COST FUNCTION OF ENGINE SIZE, WEIGHT, AND PERFORMANCE

OPERATING COST

DOC - AMERICAN AIRLINES DOC

- MODIFICATION OF ATA-67 MODEL

- INCLUDES CONCEPTUAL DESIGN VARIABLES AND REAL WORLD EXPERIENCE

IOC - LOCKHEED GEORGIA IOC

- INDUSTRY STANDARD

- SOME CONCEPTUAL DESIGN VARIABLES

Figure 5

BASELINE MISSION AND ECONOMICS

For this study, three different classes of subsonic commercial aircraft were used (short*, medium,† and medium-to-long range‡). The baseline missions and economic assumptions are shown in figure 6. The missions are intended to be representative of realistic missions; therefore, range is not the only difference. The same economic assumptions were used for all aircraft. Baseline aircraft geometries were developed from existing aircraft of the same class. Scalable engine data appropriate to each vehicle size was used as input to FLOPS. Design variables for these aircraft were aspect ratio, wing area, wing sweep, wing thickness-chord ratio, engine thrust, and takeoff gross weight. In order to see the full effect of the optimization process, the design variables were not constrained to realistic values. The mission requirements (in particular takeoff field length) did help maintain a certain amount of realism in the designs. Only selected results of the study will be presented in the following discussion due to limitations of time and space.

| | * <u>SRAC</u> | + <u>MRAC</u> | ‡ <u>LRAC</u> |
|----------------------|---------------|---------------|---------------|
| RANGE, N.MI. | 1000 | 2500 | 4500 |
| CRUISE MACH | 0.78 | 0.80 | 0.82 |
| MAX CRUISE ALT., FT. | 35000 | 40000 | 45000 |
| PASSENGERS | 100 | 200 | 500 |
| TOFL, FT. | 6000 | 7000 | 10000 |
| NO. OF ENGINES | 2 | 2 | 4 |

BASELINE ECONOMIC ASSUMPTIONS (FOR ALL AIRCRAFT)

YEAR FOR CALCULATIONS = 1987
 SPARES FACTOR FOR AIRFRAME = 0.10
 SPARES FACTOR FOR ENGINES = 0.30
 AIRFRAME PRODUCTION QUANTITY = 400
 NO. OF PROTOTYPE AIRCRAFT = 2
 NO. OF FLIGHT TEST AIRCRAFT = 2
 PRIOR NO. OF ENGINES PROCURED = 0
 DEPRECIATION PERIOD = 14 YEARS
 LIFETIME = 14 YEARS
 RESIDUAL VALUE AT END OF LIFE = 15%
 FUEL PRICE = \$0.50/GALLON

Figure 6

EFFECT OF OPTIMIZATION PARAMETER ON WING PLANFORM

A comparison of the wing planform obtained for the medium-range aircraft when optimized for minimum acquisition cost, takeoff gross weight, life cycle cost, direct operating cost, and minimum fuel burned is shown in figure 7. The aspect ratio, wing area, and wing sweep are represented in the planform sketch. The wings are drawn with a common root quarter-chord location. In terms of increasing aspect ratio and wing area, the planforms start with minimum acquisition cost, TOGW, LCC, DOC, and end with minimum fuel. Aspect ratio can be used as a measure of technology by recognizing that a larger aspect ratio wing is going to be more aerodynamically efficient but also more expensive to build. The minimum acquisition cost airplane is primarily dependent on the structural weight of the airplane, the minimum fuel airplane is primarily dependent on the fuel weight, and the TOGW airplane depends on both the structural weight and the fuel weight. The DOC airplane is dependent on the cost of fuel, the cost of maintenance, and has a secondary dependence on the acquisition cost of the aircraft. The LCC airplane balances both the operating and acquisition costs of the airplane. The next three figures will investigate the differences between these configurations further.

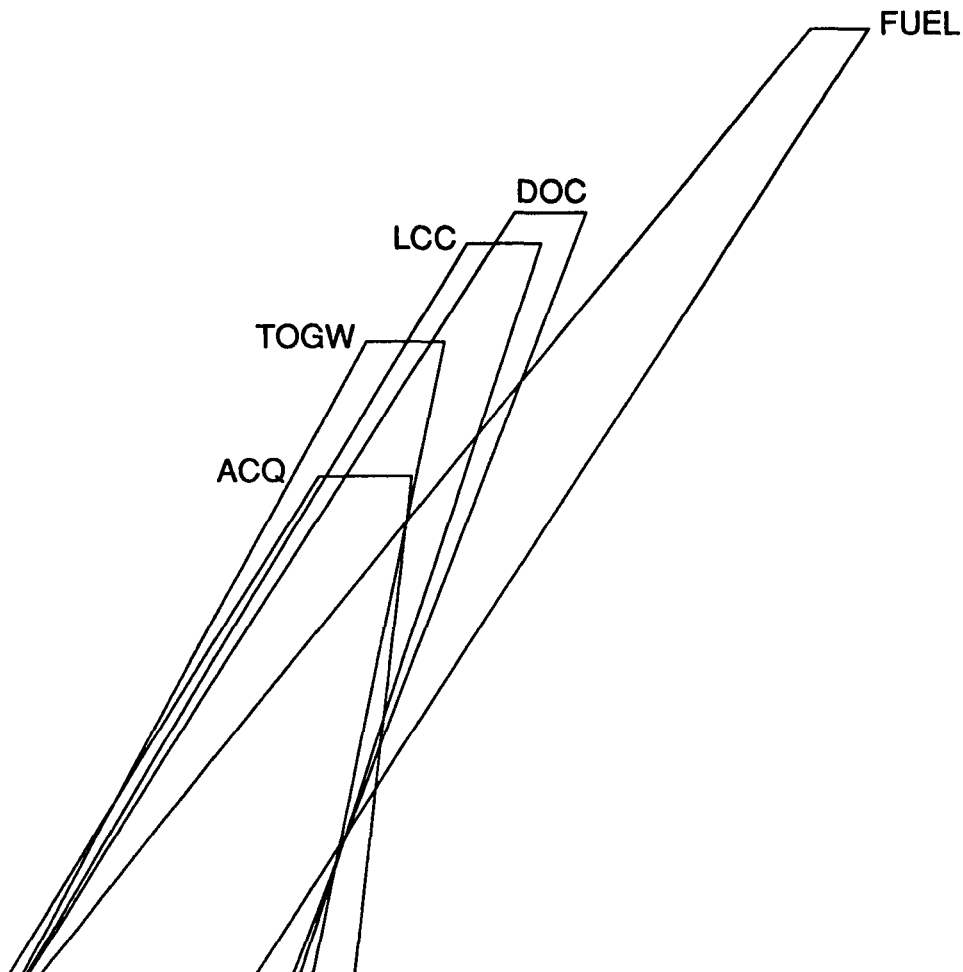

Figure 7

GROSS WEIGHT AND FUEL CONSUMPTION

The bars in the graphs of figure 8 each represent the value of TOGW and fuel burned per flight associated with the medium-range aircraft which have been optimized for minimum acquisition cost, TOGW, LCC, DOC, and fuel burned. The minimum fuel airplane has the highest TOGW while the minimum acquisition cost airplane burns the most fuel. With the exception of the minimum acquisition cost airplane, TOGW increases with increasing aspect ratio and wing area. The amount of fuel burned decreases for all cases with increasing aspect ratio.

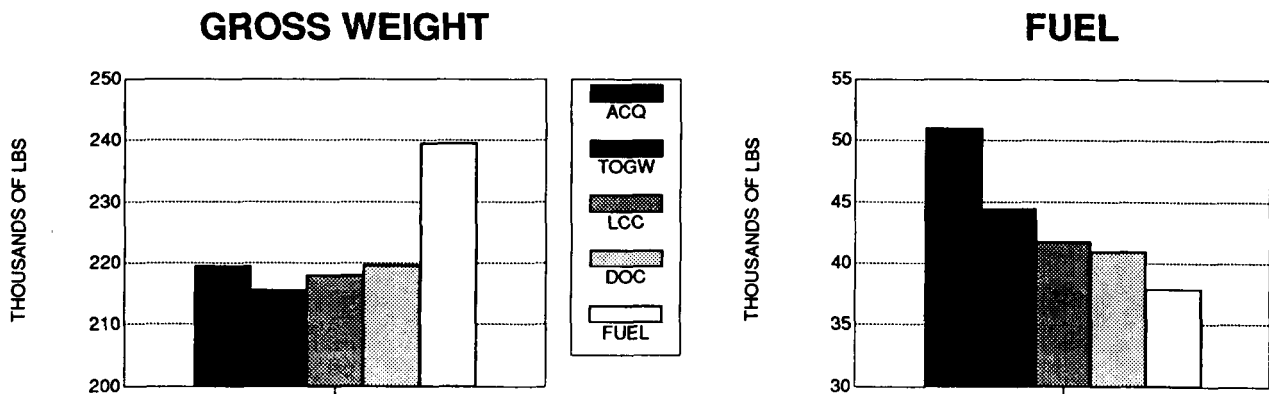

Figure 8

WEIGHT AND COST

Figure 9 illustrates the direct relationship between empty weight, acquisition cost and technology level. The minimum acquisition cost airplane has the lowest empty weight while the minimum fuel airplane has both the highest empty weight and highest acquisition cost. The minimum LCC airplane has a slightly higher empty weight and acquisition cost than the minimum TOGW airplane.

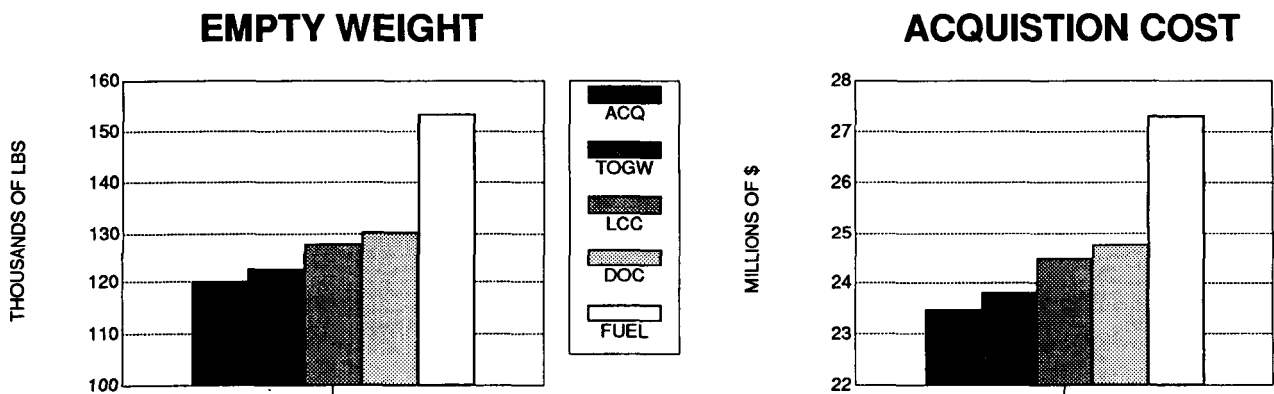

Figure 9

DIRECT OPERATING AND LIFE CYCLE COSTS

The direct operating cost and life cycle cost for the various optimized aircraft are shown in figure 10. Direct operating cost is the total over the lifetime of the aircraft. With the exception of the minimum fuel airplane, DOC decreases with increasing aspect ratio. The LCC of the configuration follows the technology trends with the extremes (minimum fuel and acquisition cost airplanes) having very high LCC and the minimum TOGW, LCC, and DOC airplanes having lower LCC. Both the short- and medium-to-long range airplanes showed similar results, although fuel played a much more important role in the medium-to-long range airplane. The minimum LCC and DOC airplanes are dependent on the economic assumptions. The DOC and LCC airplanes are very similar because with these economic conditions the elements that determine DOC (fuel, maintenance, salaries, acquisition cost, and so on) are of equal importance with the elements that determine LCC (acquisition cost and DOC). In the following discussion the effects of economic assumptions such as fuel cost and lifetime will be examined.

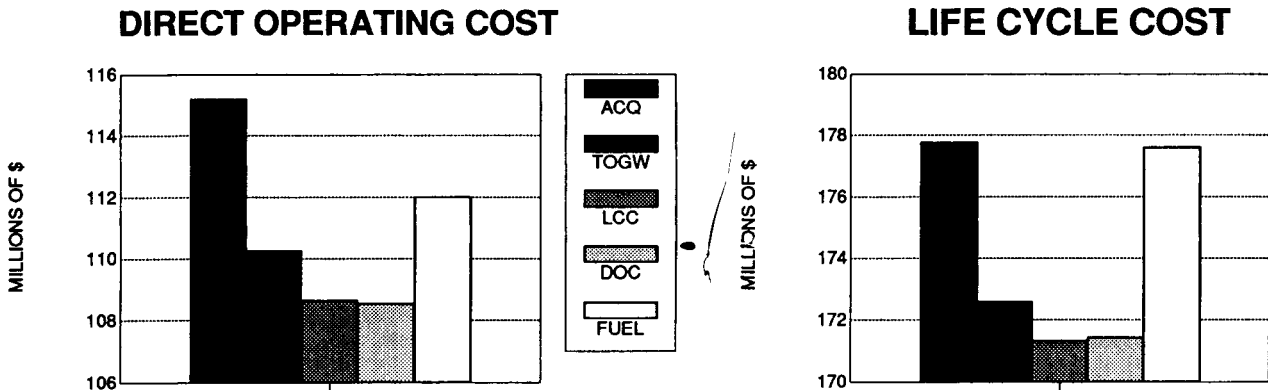

Figure 10

FUEL PRICE SENSITIVITY

Wing planforms resulting from optimization runs for minimum LCC and DOC for the medium-range airplane with fuel at \$2.00 per gallon are shown in figure 11. For reference the baseline minimum fuel, LCC, and DOC planforms are also shown. The effect of increasing fuel price is to increase the amount of technology that can be included for both the minimum LCC and DOC airplanes. In fact, the minimum DOC wing planform becomes nearly identical to the minimum fuel planform.

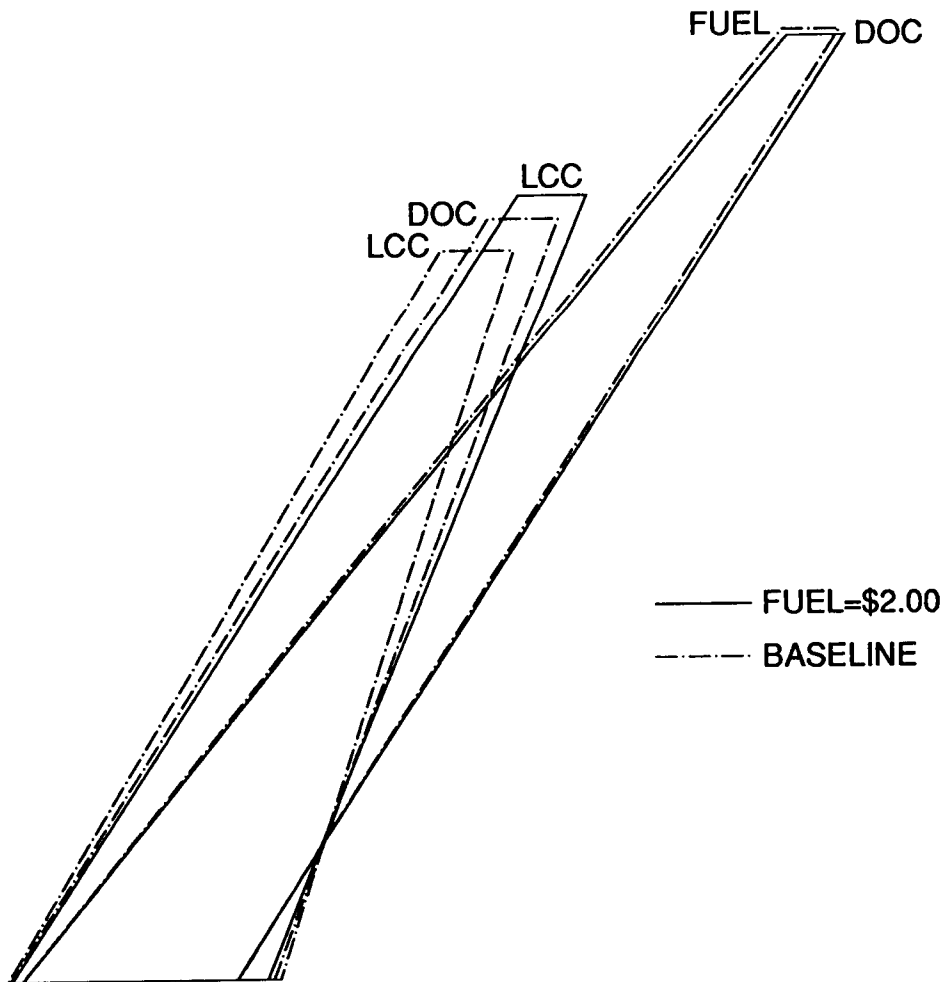

Figure 11

COSTS FOR INCREASED FUEL PRICE

Acquisition and life cycle cost for all of the medium-range aircraft with fuel cost of \$2.00 per gallon are shown in figure 12. Once again acquisition cost increases with increasing technology level. The minimum LCC and DOC airplanes have higher acquisition costs than before. As might be expected, the minimum DOC and minimum fuel aircraft have nearly identical acquisition cost and life cycle cost. This is because the fuel cost has become a much more important element than acquisition cost in determining DOC. The amount of technology that can be included on the minimum LCC airplane is restricted by the balance between increases in acquisition cost and decreases in direct operating cost. Additionally, the difference in life cycle cost between the minimum LCC, DOC, and fuel airplanes is not that great.

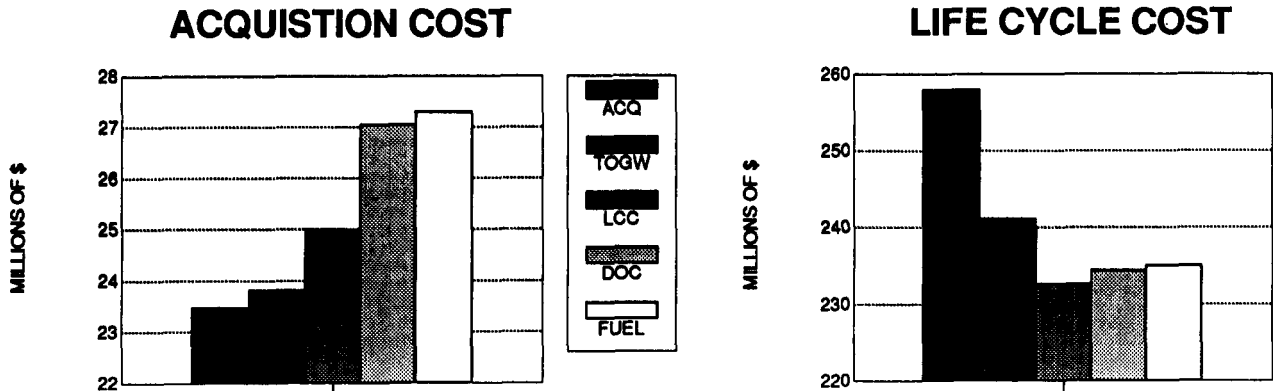

Figure 12

EFFECT OF LIFETIME AND RESIDUAL ON PLANFORM

Another important set of economic assumptions are the lifetime of the aircraft and its residual value at the end of that lifetime. Figure 13 shows the wing planform resulting from optimizing the medium-range aircraft for minimum DOC and LCC with a lifetime of eight years and a residual of 30 percent. For reference, the baseline minimum TOGW, LCC, and DOC airplane planforms are shown. Utilization of these aircraft in terms of number of flights per year is identical to the baseline. In this case, the LCC and DOC airplanes are identical. They have greater sweep but less aspect ratio than the baseline DOC and LCC aircraft. Wing areas are nearly identical.

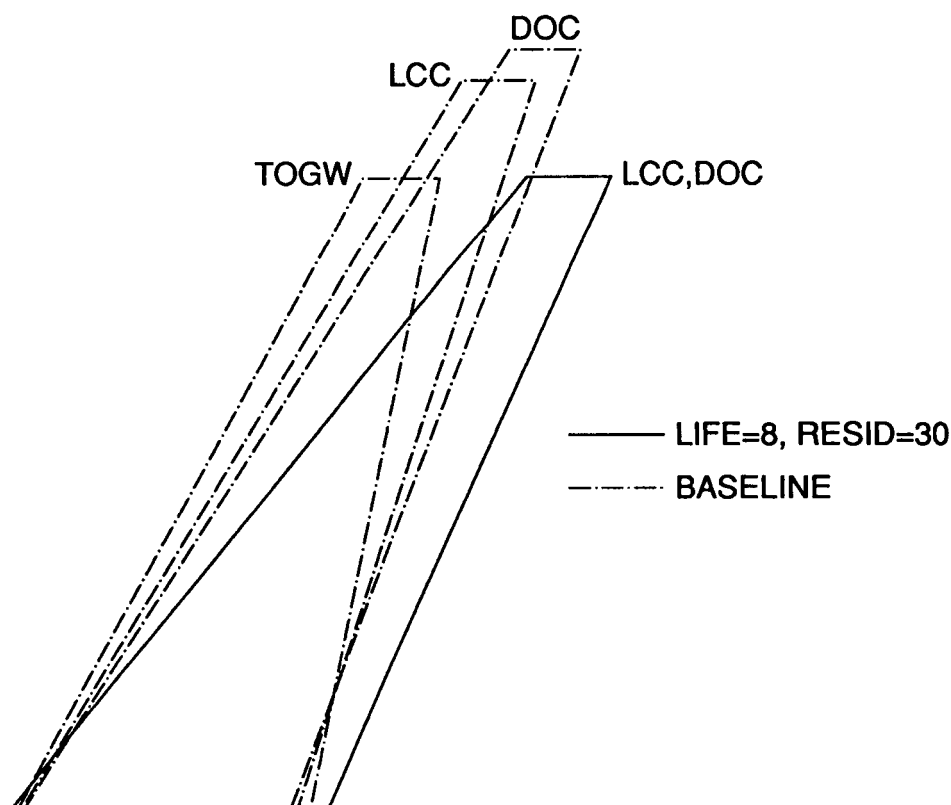

Figure 13

EFFECT OF LIFE AND RESIDUAL ON COST

Figure 14 shows the acquisition cost and LCC for all medium-range airplanes with a lifetime of eight years and residual value of 30 percent. The trends are the same as before but the reduced lifetime makes lowered acquisition cost and technology level more important than saving fuel in order to keep the life cycle cost low for both the minimum LCC and DOC airplanes.

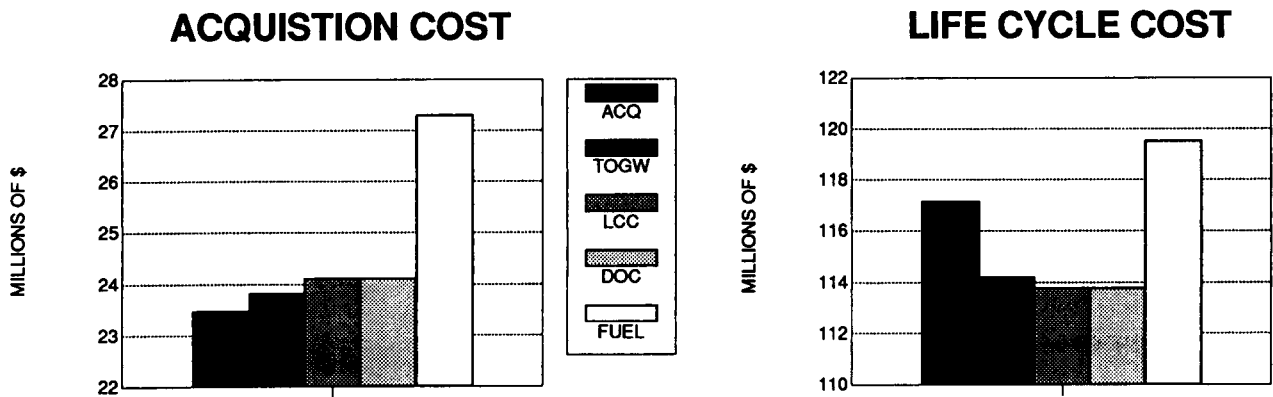

Figure 14

NUMBER OF ENGINES

The table in figure 15 illustrates one of the real payoffs of including cost in conceptual design. Each of the three classes of aircraft was optimized for minimum life cycle cost with two, three, and four engines. If the number of engines is selected based on minimum TOGW, empty weight, or fuel burned, in all cases four engines would be chosen. However, if the number of engines is based on minimum LCC or DOC, only in the case of the medium-to-long range aircraft would four engines be chosen. The short- and medium-range aircraft both have minimum DOC and LCC with two engines. If minimum acquisition cost is the criterion for selection, four engines would be chosen for the medium- and medium-to-long range aircraft; once again two engines would be selected for the short-range aircraft. For the short- and medium-range aircraft, the total cost for two engines is less than the cost for four engines. Additionally, the maintenance cost is a much greater function of number of engines than it is of engine size. Therefore, from an economic viewpoint, two engines is the logical choice. For the medium-to-long range aircraft, however, the total engine cost is approximately constant. The one-engine out requirements drive this very large airplane to very large engines. All costs increase with decreasing number of engines, making four the correct choice. This exercise was also conducted based on minimum TOGW aircraft; the results were identical. This type of application makes a very strong argument for considering cost in the conceptual design process.

| | SRAC | | | MRAC | | | LRAC | | |
|--------------------|--------|--------|--------|--------|--------|--------|--------|--------|--------|
| | 4 | 3 | 2 | 4 | 3 | 2 | 4 | 3 | 2 |
| TOGW, LB | 86705 | 92014 | 90064 | 201616 | 215645 | 218086 | 753658 | 807769 | 948147 |
| EW, LB | 50386 | 54939 | 52613 | 113551 | 125856 | 127938 | 379740 | 409937 | 497152 |
| FUEL, LB | 12402 | 13031 | 13541 | 39686 | 41212 | 41784 | 251055 | 274610 | 327932 |
| THRUST, LB | 5218 | 8184 | 13839 | 14384 | 21437 | 34542 | 33750 | 54994 | 122863 |
| T/W | 0.24 | 0.27 | 0.31 | 0.29 | 0.30 | 0.32 | 0.18 | 0.20 | 0.26 |
| LCC, M\$ | 114.50 | 118.36 | 114.14 | 173.11 | 176.25 | 171.32 | 395.40 | 414.28 | 457.42 |
| DOC, M\$ | 79.20 | 81.62 | 78.37 | 111.28 | 112.39 | 108.67 | 250.03 | 264.55 | 301.71 |
| ACQ, M\$ | 11.90 | 12.92 | 11.81 | 23.49 | 25.44 | 24.48 | 55.92 | 59.48 | 64.14 |
| COST/ENG, M\$ | 0.38 | 0.51 | 0.72 | 0.71 | 0.86 | 1.15 | 1.14 | 1.49 | 2.26 |
| TOT. ENG COST, M\$ | 1.52 | 1.53 | 1.44 | 2.84 | 2.58 | 2.30 | 4.56 | 4.47 | 4.52 |

Figure 15

TECHNOLOGY EFFECT ASSUMPTIONS

As mentioned earlier, FLOPS has the capability to account for advanced technologies through the use of complexity factors. Similar factors were included in the LCC module. Complexity factors can be applied to airframe RDT&E, engine RDT&E, and manufacturing and operating costs associated with the individual aircraft components and systems. Using these factors it is possible to specify a technology improvement (or decrement) and a corresponding cost increase (or decrease). If these increments are known, they may be used to determine their effect on the configuration. However, one of the true values of this conceptual design system is the capability to evaluate the sensitivities of the aircraft to these technology and cost increments. An example is presented for an increase in aerodynamic technology for the medium-range aircraft. Figure 16 shows the aerodynamic performance improvements assumed and the corresponding cost increments. Three sets of cost increments (no additional cost, 20 percent additional cost and 40 percent additional cost in each element shown) were used to evaluate the sensitivity of this configuration to the change in cost. (All other economics are the baseline assumptions.) The results will be described in the next three figures.

PERFORMANCE IMPROVEMENTS IN AERODYNAMICS

ADVANCED TECHNOLOGY AIRFOIL
40% LAMINAR FLOW ON
WING, HORIZONTAL TAIL, VERTICAL TAIL,
BODY AND NACELLES

COST INCREASES

| | | | |
|----|-----|-----|---|
| 0% | 20% | 40% | IN AIRFRAME R&D |
| 0% | 20% | 40% | IN MANUFACTURING OF WING, BODY, NACELLES, TAIL |
| 0% | 20% | 40% | IN OPERATING OF WING, BODY, NACELLES |
| 0% | 20% | 40% | IN MAINTENANCE LABOR RATE |

Figure 16

TECHNOLOGY EFFECT ON WING PLANFORM

The wing planform for the medium-range aircraft when optimized for minimum life cycle cost with the aerodynamic performance improvements and 40% cost increase is shown in figure 17. For comparison the baseline minimum LCC planform is also shown. The advanced aerodynamic technology allows the wing to use less sweep, span, and area and more thickness to obtain an optimum wing for minimum LCC.

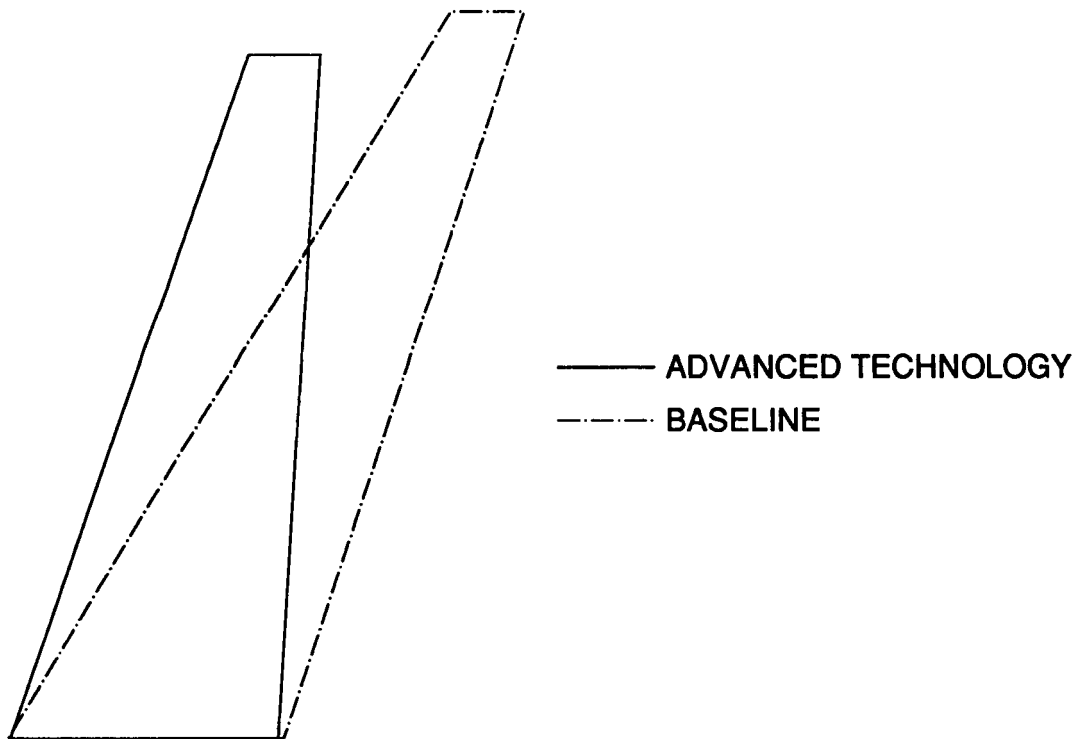

Figure 17

TECHNOLOGY EFFECT ON TOGW AND LCC

The TOGW and LCC of the medium-range aircraft when optimized for minimum LCC are shown in figure 18. Applying the aerodynamics technology results in a large decrease in TOGW. When there is no associated cost increase, the LCC is also dramatically reduced. With a 20 percent cost increase the LCC is still less than the baseline. If the cost increase is as much as 40 percent, the resulting LCC is greater than the baseline. For this set of economic conditions, a cost increase of up to approximately 30 percent appears to be tolerable for this technology set.

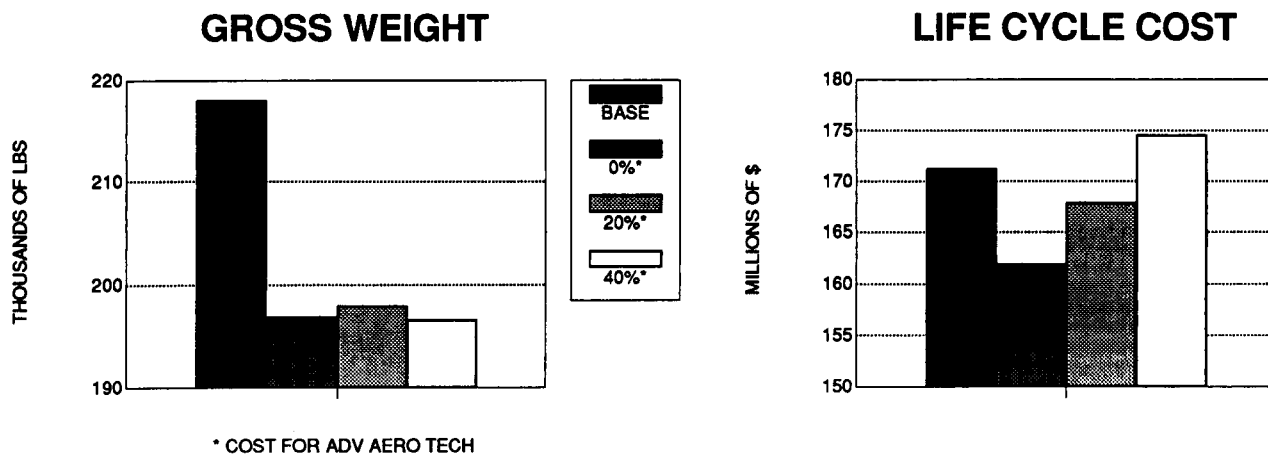

Figure 18

TECHNOLOGY EFFECT ON ACQUISITION COST AND DOC

Figure 19 shows the acquisition cost and direct operating cost for the configuration discussed in the previous figure. As would be expected, for no increase in cost associated with advanced technology, the acquisition and direct operating costs are less than for the baseline aircraft. For a 20 percent increase in cost, the acquisition cost is somewhat greater than the baseline and the direct operating cost is still significantly less. A 40 percent increase in cost leads to higher acquisition and direct operating costs. Similar results were obtained for the configuration when optimized for minimum takeoff gross weight. The point where advanced technology is affordable is highly dependent on the assumed economic conditions. In addition to aerodynamics this system can handle weight, propulsion and systems technologies and costs. They may be evaluated individually or combined.

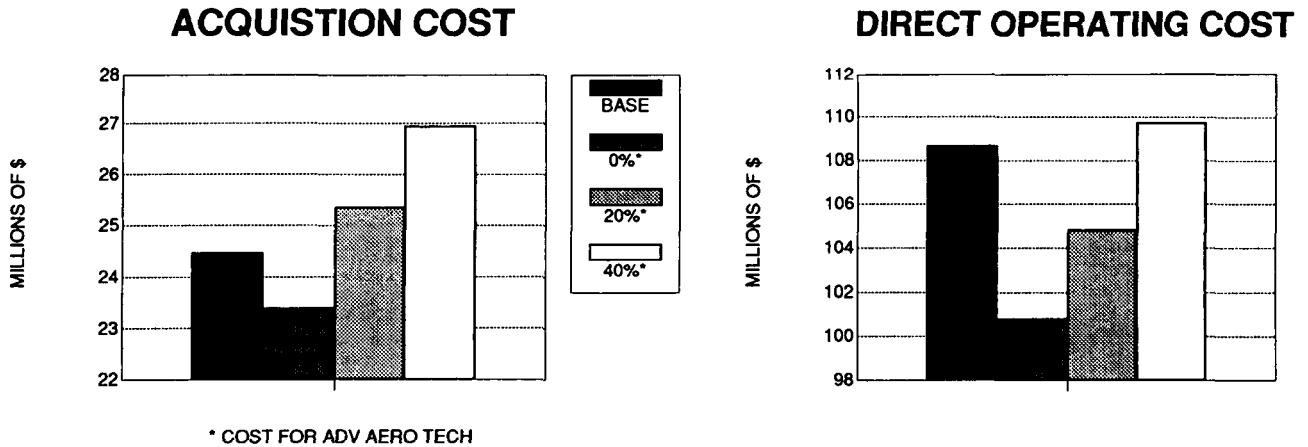

Figure 19

OPTIMIZATION OBSERVATIONS

The FLOPS optimization capability already existed and was in current use. The goal of this study was to extend the capability to include cost in the process. The modularized nature of FLOPS made this extension relatively easy. Some observations about the optimization process for this study are summarized in figure 20. For the airplanes used in this study the optimizations for TOGW and fuel generally converged without any problem. The acquisition cost optimization also succeeded in finding the global minimum during the first run. The LCC and DOC optimizations generally converged but not to the global minimum the first time. It was usually necessary to restart the runs at least once. During all of the optimization runs there was a lot of movement of the design variables. However, runs did tend to encounter problems and abort if the starting point was too far from the optimum. It was interesting to note that this study did uncover two problems with the FLOPS analysis. In trying to optimize the medium-range aircraft for minimum fuel burned, the aspect ratio went to 26, the wing sweep to 88 degrees, and the wing span to 225 feet. The problem was an error in the sweep portion of the wing weight equation. When that was corrected everything worked fine. Another problem uncovered was a weakness between the aerodynamics and weights for taper ratio. For all aircraft the taper ratio optimized to near zero. The final solution to this problem was to recognize that taper ratio is not a critical parameter and to leave it fixed for all configurations.

- EXISTING FLOPS OPTIMIZATION FOR TOGW AND FUEL WORKED VERY WELL FOR THESE AIRPLANES
- TYPICALLY GLOBAL MINIMUM FOUND DIRECTLY FOR MINIMUM ACQUISITION COST
- GENERALLY NECESSARY TO RESTART DOC AND LCC OPTIMIZATIONS AT LEAST ONCE
- DESIGN VARIABLES CHANGED SIGNIFICANTLY DURING OPTIMIZATION PROCESS; HOWEVER, SOMETIMES TOO MUCH CHANGE ABORTED THE PROCESS
- THIS STUDY DID UNCOVER TWO PROBLEMS WITH THE ANALYSIS:
 - ERROR IN WING SWEEP EQUATION FOUND BY MEDIUM-RANGE AIRCRAFT MINIMUM FUEL CASE
 - WEAK LINK BETWEEN AERODYNAMICS AND WEIGHTS FOR TAPER RATIO -- ALWAYS OPTIMIZED TO TAPER RATIO ≈ 0

Figure 20

CONCLUSIONS

Figure 21 summarizes conclusions from this study. A life cycle cost module has been added to FLOPS, allowing the additional optimization variables of life cycle cost, direct operating cost, and acquisition cost. Extensive use of the methodology on short-, medium-, and medium-to-long range aircraft has demonstrated that the system works well. Results from the study show that optimization parameter has a definite effect on the aircraft, and that optimizing an aircraft for minimum LCC results in a different airplane than when optimizing for minimum TOGW, fuel burned, DOC, or acquisition cost. Additionally, the economic assumptions can have a strong impact on the configurations optimized for minimum LCC or DOC. Also, results show that advanced technology can be worthwhile, even if it results in higher manufacturing and operating costs. Examining the number of engines a configuration should have demonstrated a real payoff of including life cycle cost in the conceptual design process: the minimum TOGW or fuel aircraft did not always have the lowest life cycle cost when considering the number of engines.

- A LCC MODULE HAS BEEN ADDED TO FLOPS, ALLOWING THE ADDITIONAL OPTIMIZATION VARIABLES OF LCC, DOC, AND ACQUISITION COST
- EXTENSIVE USE OF THE METHODOLOGY ON THREE DIFFERENT SUBSONIC TRANSPORT AIRCRAFT HAS DEMONSTRATED THAT THE SYSTEM WORKS WELL AND IS USEFUL
- RESULTS SHOW THAT
 - OPTIMIZATION PARAMETER HAS A DEFINITE EFFECT ON THE AIRCRAFT
 - OPTIMIZING FOR LCC RESULTS IN A DIFFERENT AIRCRAFT THAN OPTIMIZING FOR TOGW, FUEL BURNED, DOC, OR ACQUISITION COST
 - THE MINIMUM LCC AND DOC AIRPLANES TEND TO BE SIMILAR AND ARE DEPENDENT ON ECONOMIC CONDITIONS
 - THE MINIMUM TOGW OR FUEL AIRCRAFT DO NOT ALWAYS HAVE THE LOWEST LIFE CYCLE COST WHEN CONSIDERING THE NUMBER OF ENGINES
 - ADVANCED TECHNOLOGY CAN BE WORTHWHILE EVEN IF IT RESULTS IN HIGHER MANUFACTURING AND OPERATING COSTS

Figure 21

SYMBOLS

| | |
|-------|---|
| ACQ | Acquisition cost |
| ATA | Air Transport Association |
| DOC | Direct operating cost |
| IOC | Indirect operating cost |
| LCC | Life cycle cost |
| RDT&E | Research, development, testing and evaluation |
| TOGW | Takeoff gross weight |

REFERENCES

1. Nicolai, Leland M.: Fundamentals of Aircraft Design. METS, Inc., 6520 Kingsland Court, San Jose, California, 95120, 1975.
2. Brown, Robert B.: Design of Very Large Airplanes for Least System Cost. Aircraft Design, Integration and Optimization--Volume 1. AGARD CP-147, 1973, paper 15.
3. McCullers, L. A.: Aircraft Configuration Optimization Including Optimized Flight Profiles. Multidisciplinary Analysis and Optimization--Part I. NASA CP-2327, 1984, pp. 395-412.
4. Johnson, Vicki S.: Life Cycle Cost in the Conceptual Design Process. AIAA Paper 87-2889, 1987.
5. Eide, Donald G.: Cost Estimating Relationships for Airframes in the Development and Production Phases. NASA TM-80229, 1980.
6. Beltramo, Michael N.; and Morris, Michael A.: Application of Parametric Weight and Cost Estimating Relationships to Future Transport Aircraft. SAE Paper 1292, 1979.
7. Nelson, J. R.; and Timson, F. S.: Relating Technology to Acquisition Costs: Aircraft Turbine Engines. The Rand Corporation, R-1288-R, 1974.
8. A New Method for Estimating Current and Future Transport Aircraft Operating Economics. American Airlines, NASA CR-145190 (Revised), 1978.
9. Stoessel, Robert R.: A Proposed Standard Method for Estimating Airline Indirect Operating Expense. Lockheed-Georgia Company, LW70-500R, 1970.
10. Standard Method of Estimating Comparative Direct Operating Costs of Turbine Powered Transport Airlines. Air Transport Association of America, December 1967.