

**N89-25212**

**AIRCRAFT DESIGN OPTIMIZATION  
WITH MULTIDISCIPLINARY PERFORMANCE CRITERIA**

**Stephen Morris and Ilan Kroo  
Department of Aeronautics and Astronautics  
Stanford University  
Stanford, California**

**PRECEDING PAGE BLANK NOT FILMED**

## ABSTRACT

The presence of multidisciplinary performance criteria and constraints complicates the process of aircraft design and optimization. This paper addresses some of the problems that arise as performance measures from very different fields are compared and tradeoffs are made. The work focuses on the interaction between structural weight, aerodynamic performance, and handling qualities. A method for dealing with such design problems is described and several example cases are considered.

By minimizing a cost function consisting of both conventional performance criteria and a measure of aircraft handling qualities, a design with maximum performance for a specified level of handling can be achieved. Handling qualities are measured using a quadratic cost function similar to that used in the design of optimal feedback control systems. This function is proportional to the difference between the unforced response of the aircraft and a "model" case with dynamics that are considered acceptable. The variables to be optimized may include both aircraft design parameters (e.g. span, tail area, skin thickness) and control system feedback gains. The design variables are determined by an unconstrained numerical optimization procedure, using penalty functions to enforce both explicit and implicit constraints. The method is most useful in the simultaneous design of airframe and flight control systems to achieve improved handling, and for cases in which the handling and performance are highly coupled by the design parameters. In certain cases results obtained by this simultaneous design procedure are substantially better than those obtained by the usual sequential design methods.

Three example design problems using this methodology are discussed: tail sizing for minimum trimmed drag with longitudinal handling qualities constraints; wing weight minimization with aeroelastic constraints; and oblique-wing aerodynamic design for dynamic mode decoupling.

## INTRODUCTION

The dynamic response of an aircraft is often an important aspect of its design; yet the analysis of handling qualities and control system design are often performed after the major aerodynamic and structural properties have been established. In many cases, this sequential approach to multidisciplinary design leads to suboptimal results. The current work was motivated by one such case — the design of an oblique wing aircraft — in which achieving the desired aerodynamic performance with acceptable handling requires an integrated approach.

The design method used in this case and in the two other examples discussed here, includes a measure of the aircraft dynamic response as an integral part of the overall objective function. Numerical optimization is used to determine the values of various design parameters which minimize the composite performance index. These design variables may include both geometric properties and control system feedback gains but are not limited to full state feedback. This means that the method can be used to design a system to meet desired dynamic response requirements without a feedback control system at all, provided sufficient degrees of freedom are available in the design variables.

### Sequential Design

- Sub-optimal performance achieved with sequential disciplinary approach to design optimization

### Integrated Design

- Objective function is a weighted combination of a handling qualities measure and other performance quantities
- Aircraft configuration variables and / or control system gains used as design variables
- Method is not restricted to full-state feedback (optimal control theory) — passive designs possible

## COMPOSITE OBJECTIVE FUNCTION

A variable-metric, quasi-Newton method (QNMDIF, Ref. 1) is used to determine values of the design variables that minimize the composite objective function. This function consists of three terms: the non-dynamic performance measure, the weighted dynamic performance, and the constraint violation penalty function.

The non-dynamic performance variable may include such quantities as structural weight, drag, or direct operating cost. This component may be excluded if the goal is solely to improve dynamics.

$J_d$  provides a measure of the aircraft's dynamic response by comparison with the unforced response of a model case. This term is identical to the performance index used in optimal control design, but the feedback controller in this method is not restricted to full-state feedback. As the weighting parameter,  $K_d$ , is varied from zero to a large number, the optimal solution moves from one in which dynamics are not considered to one which is required to achieve the specified dynamics. This permits a designer to evaluate the significance of dynamic performance constraints on the final solution.  $J_d$  is normalized so that it approaches 1.0 as the design approaches neutral stability.

The third term in the objective function includes penalty functions, used to enforce explicit and implicit constraints in the synthesis.

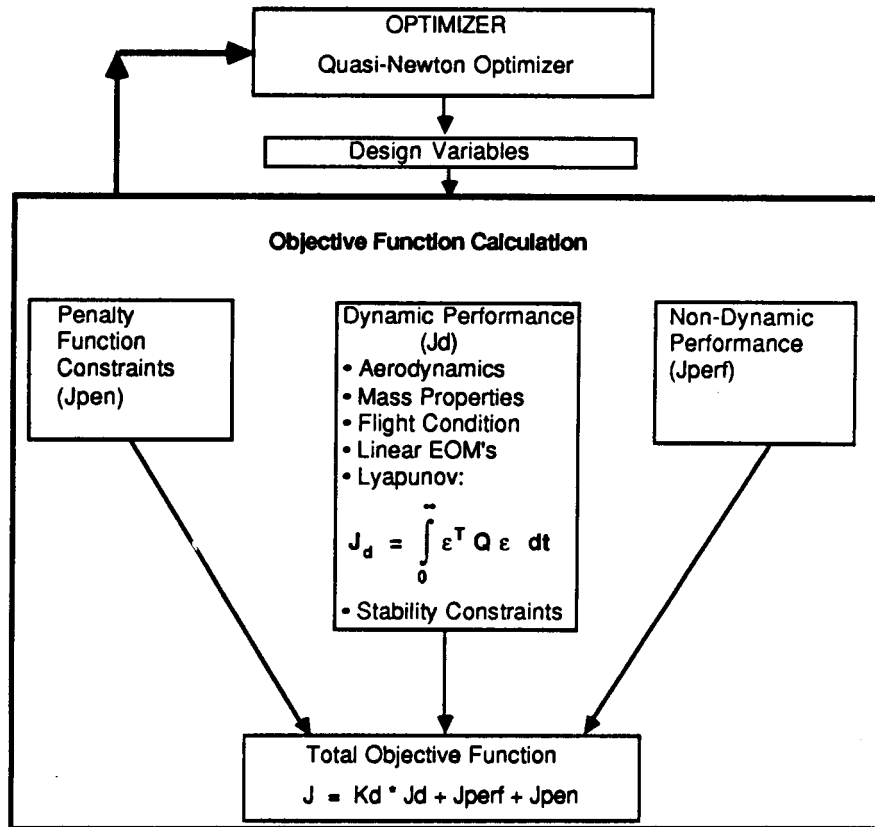

## DYNAMIC PERFORMANCE INDEX

A key aspect of this approach is the calculation of the dynamic performance index,  $J_d$ . It consists of a weighted integral over time of the difference in the state vectors of the current system and a model system whose dynamics are considered ideal. An additional term representing the control surface activity may also be included. The matrices  $[Q]$  and  $[R]$  (see below) contain weighting factors for the state error and control activity, respectively. The solution for the scalar handling quality index is obtained by solving three Lyapunov matrix equations.

The non-dynamic performance and penalty function constraints are problem specific quantities and their evaluation will be discussed in the design examples only. The dynamic performance index calculation requires that the linearized equations of motion for the aircraft be created as a function of the design variables at each objective function evaluation. This portion of the synthesis can be the most costly in terms of CPU time, particularly if the aerodynamic stability derivatives must be re-evaluated. The overall utility of this method relies on the careful choice of the analysis routines which evaluate the matrices shown in the equations of motion below. Methods which capture the essential physical phenomena and minimize computation time are desired.

Because the control gains are design variables in the optimizer loop, the controller can have any linear feedback architecture, including no controller (passive design). If full-state feedback is desired the optimal control gains may be calculated within the objective function evaluation by solving the associated algebraic Riccati equation (Refs. 2,3). This removes the control gains from the optimization loop but fixes the control system architecture.

### Linearized Equations of Motion

$$\dot{X} = [A]X + [B]U$$

$$U = [C]X \quad (\text{Any Linear Feedback Control Law})$$

### Model Following Design

$$\varepsilon = X - X_m \quad \text{where} \quad \dot{X}_m = [A_m]X_m$$

### Dynamic Performance

$$J_d = \int_0^{\infty} (\varepsilon^T Q \varepsilon + U^T R U) dt$$

Solution is found from three Lyapunov Equations:

$$1. [A - BC]^T [P1] + [P1][A - BC] + [Q + C^T R C] = 0$$

$$2. [A - BC]^T [P2] + [P2][A_m] + [Q] = 0$$

$$3. [A_m]^T [P3] + [P3][A_m] + [Q] = 0$$

$$J_d = \text{Trace} [P1 - P2 - P2^T + P3]$$

## AFT TAIL DESIGN FOR MINIMUM TRIMMED DRAG

Three examples are presented to illustrate the use of this method. The first of these, and the simplest, is the design of a wing and tail system. The configuration is required to trim at a selected lift coefficient while minimizing drag and retaining adequate longitudinal handling qualities. Variables include horizontal tail area, and wing location; in some of the designs a reduced order controller (consisting of angle of attack feedback to the elevator) is also synthesized.

The performance index is a weighted combination of drag and  $J_d$ , the handling quality parameter.  $J_d$  is computed based on a "model" case with tail area and wing location that provide Mil. Spec. 8785C level 1 response.

In this simple example the trimmed drag is calculated analytically assuming elliptic loading on the wing and tail. Drag includes parasite drag, lift dependent viscous drag, and the vortex drag associated with the interfering lifting surfaces. Designs are also required to trim at maximum lift without tail stall. This constraint is enforced using penalty functions.

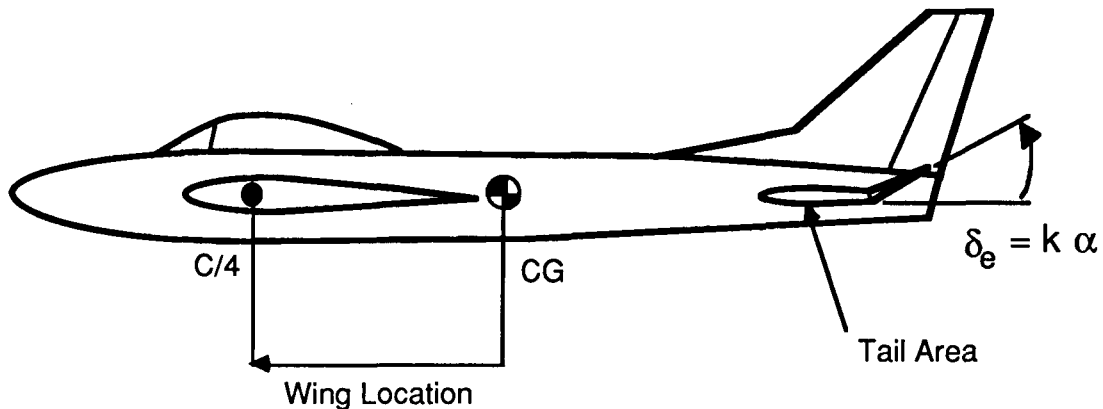

Goal: Minimize Trimmed Drag With a Given Level of Handling Quality

Design Variables: Tail Area, Wing Location, Feedback Gain (optional)

## AFT TAIL DESIGN RESULTS

The plot below shows the tradeoff between trimmed drag and handling quality parameter for the aft tail design synthesis. Curves are shown for designs with and without a feedback control system. Each point on the curves represents a unique design which is optimal for a fixed weighting of handling qualities. As the weighting on handling is increased,  $J_d$  decreases and the dynamic response of the designed aircraft approaches that of the model case. Note also that the trimmed drag increases with improved handling quality. This occurs because tail size and static margin increase as  $J_d$  decreases, with a subsequent increase in parasite and trim drag. Designs with feedback control show reduced trimmed drag for a fixed level of handling compared to designs without control systems. The synthesis method has recognized that relaxed static stability and smaller tail size can reduce trimmed drag, while feedback control can ensure adequate handling qualities by providing artificial stability. As a result, designs are automatically synthesized which are statically unstable and have an optimally designed reduced order controller to provide stability. The values of  $J_d$  where the longitudinal dynamics meet the Mil. Spec. 8785C level (1) handling quality requirements are marked on each curve.

Because the control system does not provide rate feedback, adequate damping requires some tail area; thus it is not possible to eliminate the tail completely. Even if large values of  $J_d$  (poor handling) are accepted, trim constraints still yield a non-zero tail area when the wing pitching moment at zero lift is not zero. This leads to the flat part of the curve with feedback at higher values of  $J_d$ .

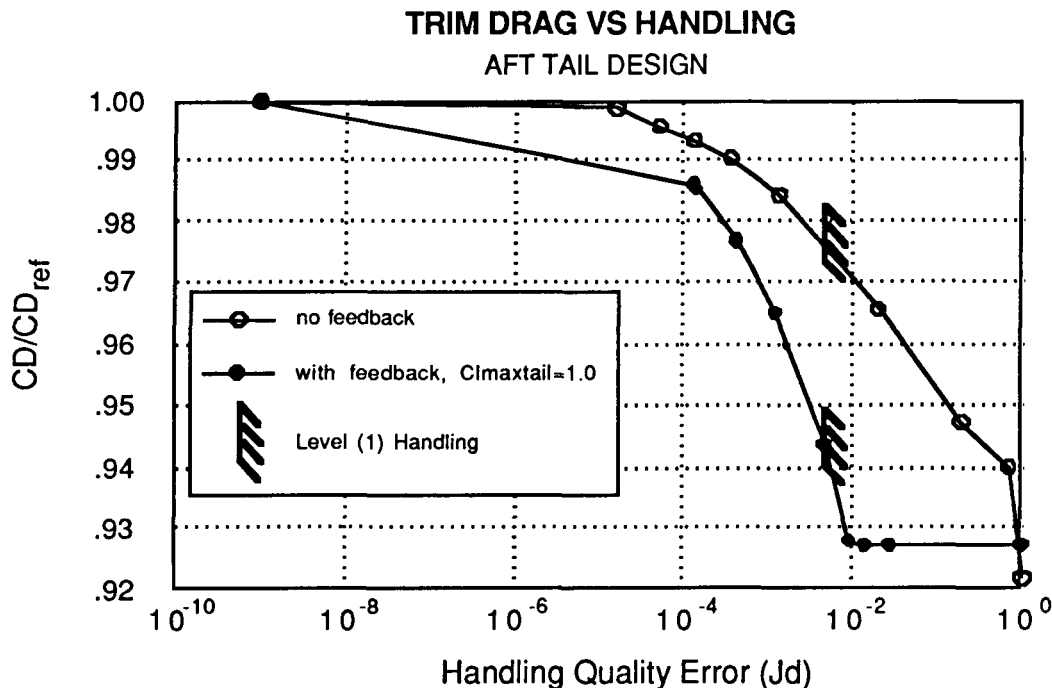

## AFT TAIL RESULTS (CONTINUED)

This plot shows the eigenvalues of each optimal design as the handling qualities weighting factor  $K_d$  is increased. When the weighting is large, the eigenvalues associated with both the short period and phugoid modes are driven to those of the model case.

The synthesis method ensures that designs with small  $J_d$  will handle better than those for which  $J_d$  is large, but because  $J_d$  is only a scalar quantity representing the sum of dynamic errors in all modes, additional information is required to determine when the response of particular modes becomes acceptable. Analysis of eigensystems or time histories of the motion allows the designer to transform the values of  $J_d$  into standard handling quality ratings (e.g. Mil. Spec. 8785).

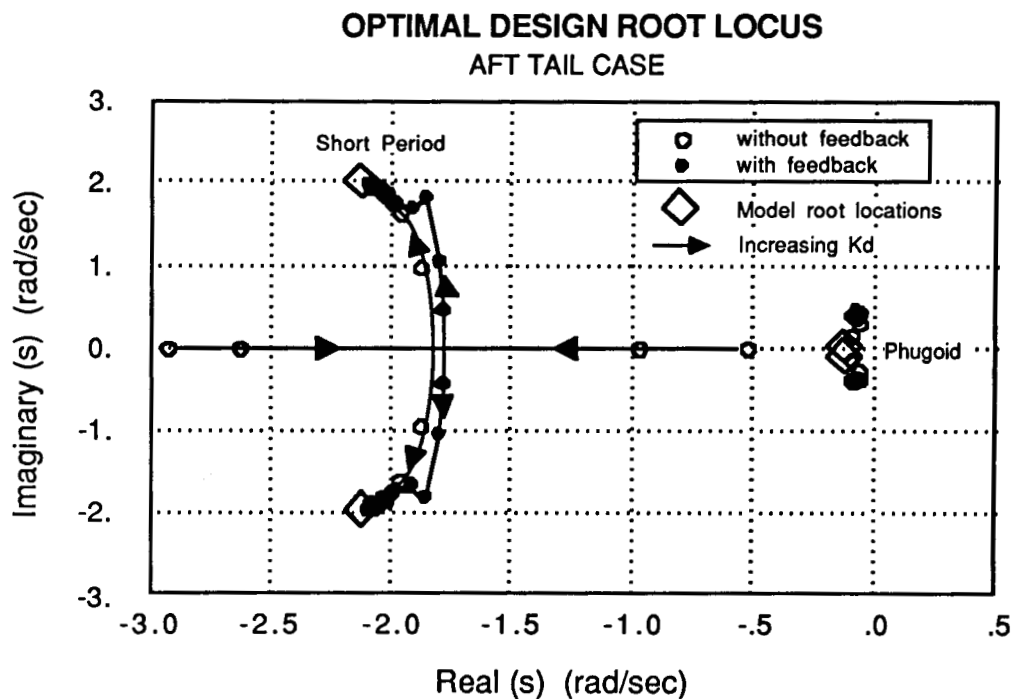



## TAILLESS AIRCRAFT FLUTTER SUPPRESSION

The second example deals with the design of a tailless aircraft for minimum wing weight and an acceptable level of handling quality. The trimmed flight condition is at a high enough speed that flutter will occur unless the wing is stiffened. The goal of this design problem is to find the wing skin thickness (along the span) which achieves acceptable longitudinal dynamics with the smallest weight penalty. Two classes of designs are considered, those without any control system and those with a reduced order feedback controller consisting of wing tip deflection fed back to symmetric elevon deflection. The dynamics model for handling quality evaluation is the same tailless aircraft with a rigid wing. The integrated design procedure improves the handling by simultaneously suppressing the flutter and driving the unrestrained dynamic modes to be most like that of a rigid aircraft. This differs from conventional flutter suppression techniques which only guarantee flutter stability and do not attempt to restore acceptable handling qualities to the unrestrained modes of the free flying aircraft.

The critical flutter mode experienced by a high aspect ratio, swept tailless aircraft consists of a coupling between the aircraft's short period and wing bending modes (Ref. 4). The unstable mode is of low frequency (2 Hz) because the structural dynamics are coupled to the rigid body modes (i.e. short period mode). The reduced frequency of this motion is small enough that quasi-steady aerodynamic theory is appropriate for modelling this instability. The equations of motion describing these dynamics include all longitudinal rigid body degrees of freedom and two elastic wing bending modes. Aerodynamic stability derivatives are predicted by a vortex lattice method (quasi-steady aerodynamics) and all mass properties in the equations of motion are updated as skin thickness changes.

Constraints are imposed on maximum allowable stress (at a maximum load factor of 3 g's) and minimum skin gauge. Maximum skin stresses are calculated using a static aeroelastic analysis which accounts for inertia relief and the effect of wing deformation on the spanwise loading.

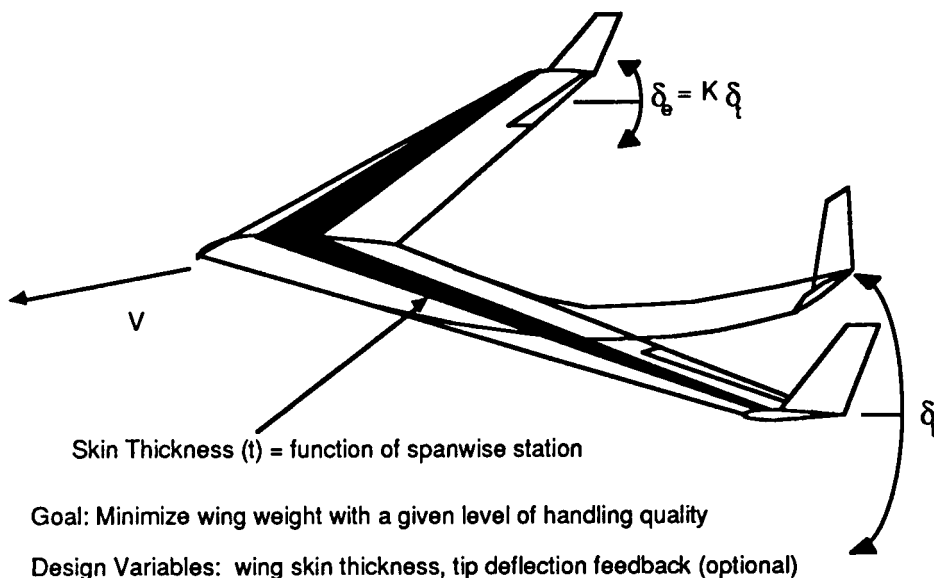

## UNRESTRAINED VEHICLE AEROELASTIC ANALYSIS

Formulation of the elastic, unrestrained vehicle's equations of motion in state vector form:

$$dX / dt = [A] X + [B] U$$

is necessary to evaluate the dynamic performance index,  $J_d$ , in this example. This is done by defining a new state vector that consists of both rigid body modes and a finite number of elastic degrees of freedom. Lagrange's method is then used to derive the equations of motion, given below in linearized form. With the equations expressed in this way, the designer can see the influence of structural flexibility explicitly, as an addition to the already familiar rigid body dynamic terms. The method can be extended to include unsteady aerodynamics by augmenting the state vector to include additional aerodynamic states with Pade approximates for the unsteady loading functions.

$$\begin{array}{cccc}
 \frac{d}{dt} \begin{bmatrix} \text{Rigid Body Terms} \\ \text{Elastic Deformation Terms} \end{bmatrix} \begin{bmatrix} X_R \\ X_E \end{bmatrix} & = & \begin{bmatrix} \text{Rigid Body Terms} \\ \text{Elastic Deformation Terms} \end{bmatrix} \begin{bmatrix} X_R \\ X_E \end{bmatrix} & + & \begin{bmatrix} \text{Rigid Body Terms} \\ \text{Elastic Deformation Terms} \end{bmatrix} \begin{bmatrix} X_R \\ X_E \end{bmatrix} & + & \begin{bmatrix} \text{Rigid Body Terms} \\ \text{Elastic Deformation Terms} \end{bmatrix} \begin{bmatrix} U \end{bmatrix} \\
 \text{Inertia \& Mass Properties} & & \text{Kinematics \& Elastic Terms} & & \text{Aerodynamic Stability Terms} & & \text{Aerodynamic Control Terms}
 \end{array}$$

$$X = \begin{bmatrix} X_R \\ X_E \end{bmatrix}$$

$$\dot{X} = [A] X + [B] U$$

## TAILLESS FLUTTER DESIGN RESULTS

Results for the tailless aircraft design example are shown below. As in the previous case, each point on the curves represents an optimal design with a specific value of handling quality weighting. Smaller values of  $J_d$  indicate improved handling, and increased values of weight ratio correspond to increased wing weight. The regions in which handling quality becomes acceptable lie to the left of the "level 1" limiting marks. Designs with feedback control show reduced wing weight since elevon deflection can provide artificial stiffness without additional material in the skins.

In a sequential design procedure the wing structure is first sized for minimum weight based on static aeroelastic loading and minimum gauge requirements. The control system (reduced order) is then designed for the best handling quality with a fixed wing design. The resulting sequentially designed aircraft has a stable flutter mode but its short period and phugoid dynamics are still highly coupled to the wing bending mode giving poor handling qualities. This design is represented by the point marked with an asterisk in the plot below.

By contrast, the integrated design procedure achieves a stable flutter mode with acceptable rigid body dynamics and does so with the least penalty in wing weight. Examination of the eigenvalues and eigenvectors shows that each of these approaches the model case as the handling quality weighting is increased. This is important to note, because the handling qualities for this example only become acceptable when the short period, phugoid, and wing bend modes are distinct and properly damped.

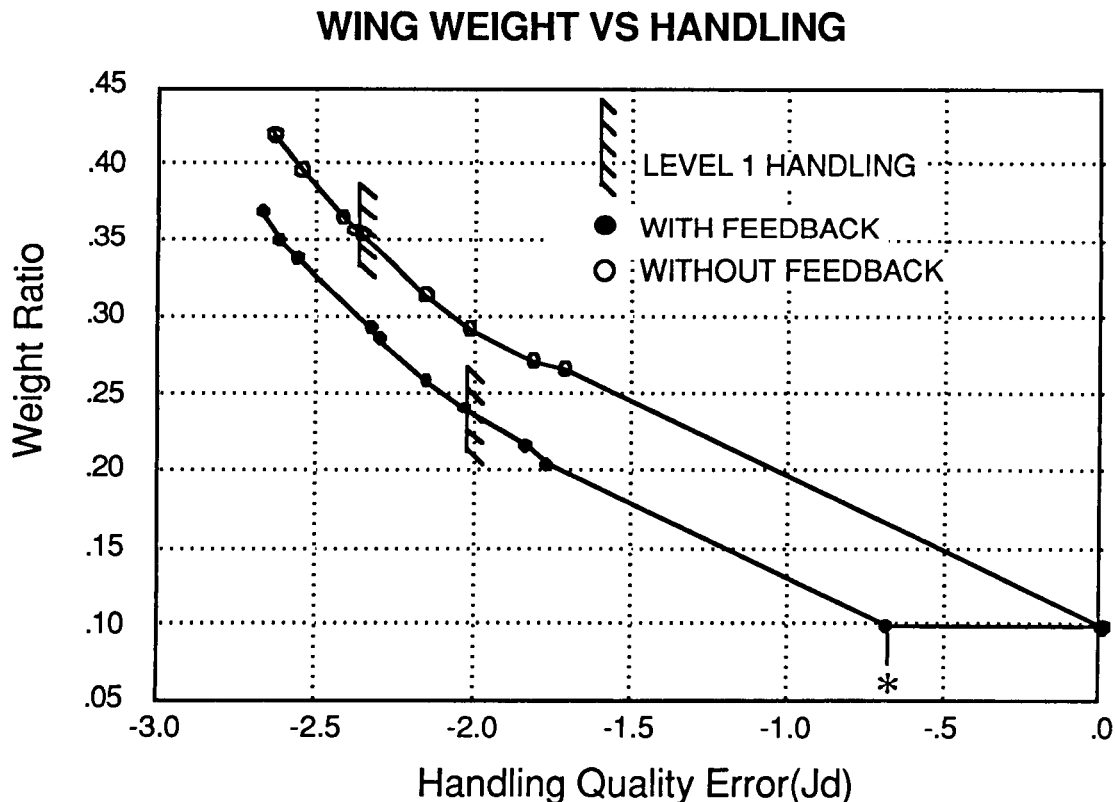

## OPTIMAL SKIN THICKNESS DISTRIBUTION

The optimal solutions for the skin thickness as a function of semi-span are shown below. Aeroelastic stability requires that the skin thickness be increased at the wing root with greater thickness required for cases without a feedback controller. Interestingly, the results also show increased skin thickness at the wing tip, which acts as a concentrated tip mass. The presence of this material further separates the frequencies of wing bending and short period dynamic modes and is a significant factor in achieving flutter stability.

In a sequential design procedure skin thickness might be increased uniformly to achieve flutter stability. It is evident from these results that a uniform distribution is far from optimal and the weight penalty incurred in the sequential design procedure would be significant.

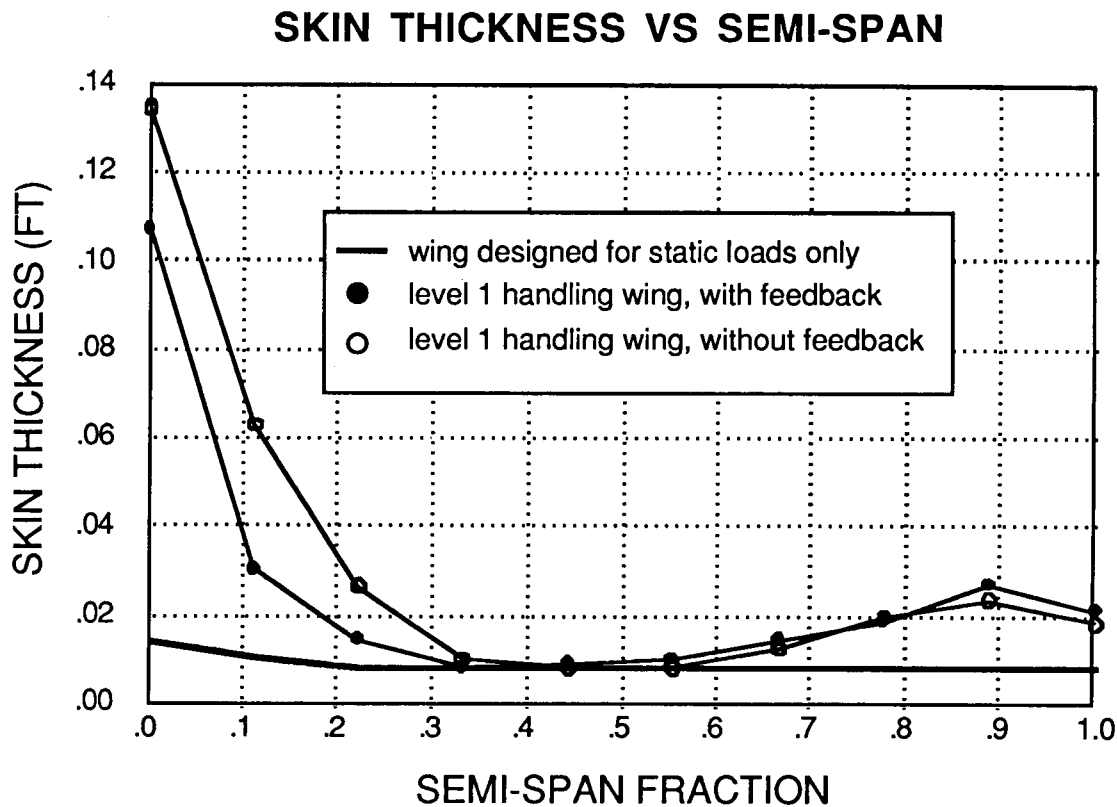

## DYNAMIC DECOUPLING OF OBLIQUE WING AIRCRAFT

The oblique wing configuration exhibits reduced transonic and supersonic drag in a lightweight variable sweep configuration. At high sweep angles (greater than 25 degrees) asymmetries in the design produce a strong coupling between the lateral and longitudinal dynamics, which results in poor handling qualities. Previous efforts to decouple the response with feedback controllers have produced less than acceptable results because of insufficient control authority and lack of controllability in certain modes (Ref. 5). By including variables related to the aircraft's geometry within the feedback control system design, however, additional degrees of freedom are available to more thoroughly decouple the aircraft's dynamic response.

In this example, six variables are optimized to achieve the maximum decoupling of lateral and longitudinal dynamics. These variables include the x and y location of the pivot relative to the fuselage and wing, the wing bank angle with respect to the fuselage, and the wing dihedral. Control system feedback gains are purposely omitted from the design variables to illustrate the use of the method for "passive" design. The results show that small variations in geometric parameters can be utilized to reduce the demands placed on the control system design. The design could be improved further by including both geometric variables and feedback gains in the optimization.

### Vortex Lattice Geometry of NASA/Rockwell F-8 OWRA

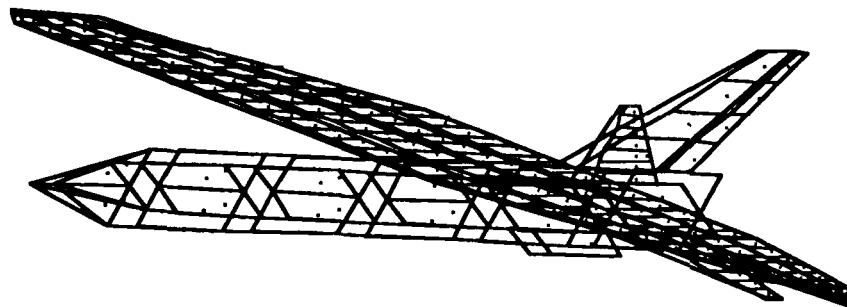

Goal: Achieve maximum decoupling in lateral and longitudinal dynamic modes by changing wing position relative to fuselage

Design Variables: Wing pivot location on fuselage, pivot location on wing, wing bank angle, dihedral

## OBLIQUE WING AERODYNAMIC COUPLING

The oblique wing asymmetry gives rise to aerodynamic and inertial couplings which are not experienced by conventional symmetric aircraft. The first figure below shows the sideforce produced as angle of attack changes with zero sideslip. This coupling force is due to the low pressure region on the leading edge which produces a sideforce when the wing is swept obliquely. Rolling moments (lower figure) are caused by a distorted wing lift distribution and wing sideforce acting above the c.g. The nonlinear character of the aerodynamic coupling suggests that consideration of multiple flight conditions is required. Additional aerodynamic coupling exists in all six forces and moments.

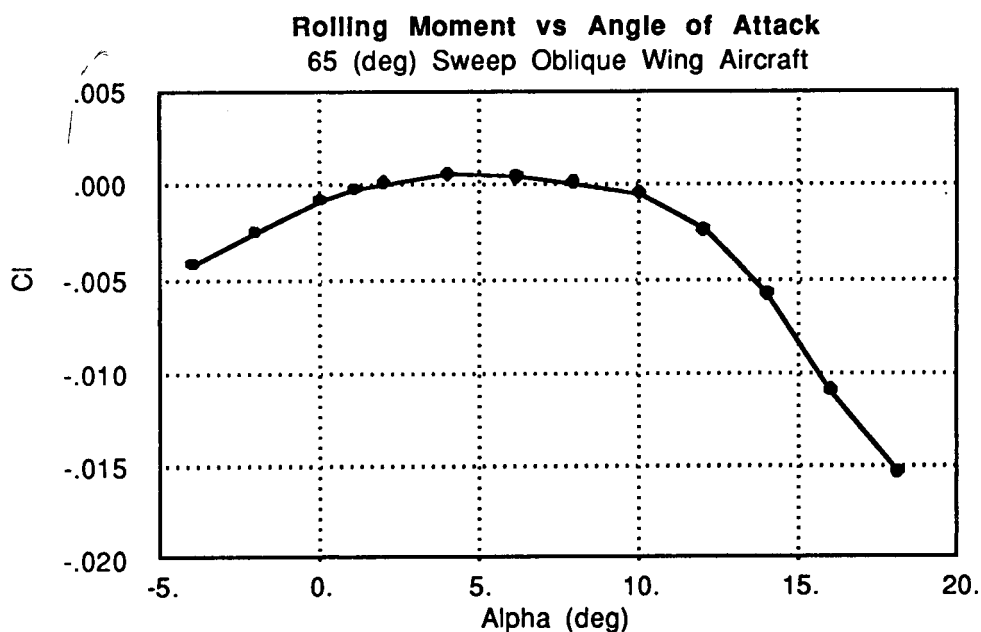
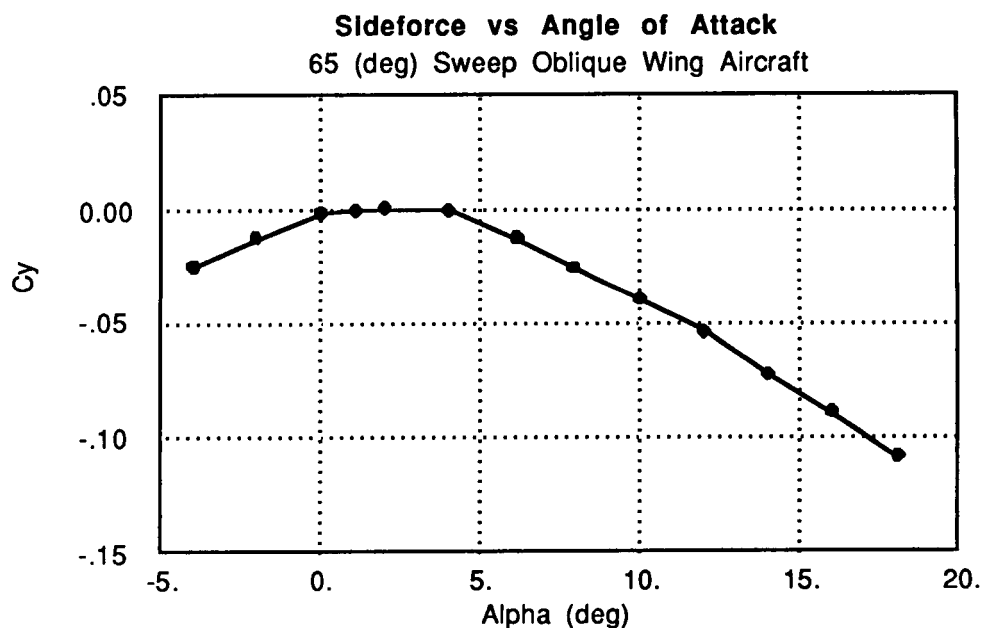

## OBLIQUE WING DESIGN RESULTS

The vortex lattice geometries for the initial guess and the optimal solution configurations are shown below. The design synthesis is carried out for a fixed oblique wing sweep of 45 degrees. The optimizer forces the dynamic response to be as close as possible to the model case, a configuration with zero oblique sweep. The optimal solution shows the wing banked 8 degrees (forward wing low) and the wing displaced slightly from the initial guess position.

All six degrees of freedom are modeled in the equations of motion. As the configuration shape is changed, the aerodynamic stability derivatives and mass properties of the aircraft are recalculated. All aerodynamics are modeled using a vortex lattice method. The final design is constrained to satisfy trim requirements (with constraints on control surface deflection) at a specified design flight condition.

In this example vertical gusts are modeled as initial condition disturbances on angle of attack. The basic design procedure weights all possible initial conditions equally, but specific perturbations can be included by using a weighted trace of the three matrices associated with the Lyapunov equations. The integrated error in the vehicle's response to these excitations is weighted for minimum lateral acceleration and roll rate response by using an appropriate Q matrix. (See discussion of dynamic performance index.)

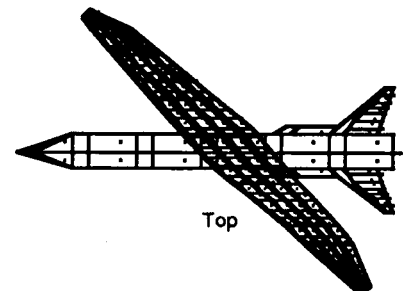
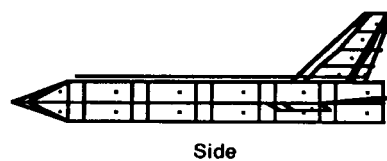
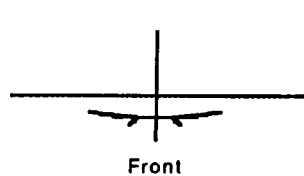

Initial Design

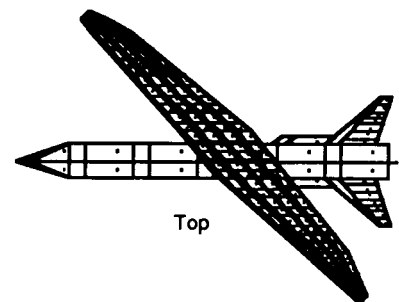
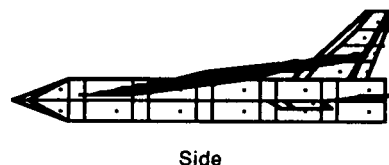
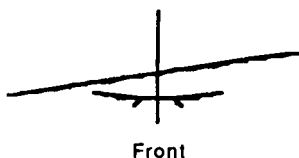

Final Design

## OBLIQUE WING DYNAMIC RESPONSE

The performance of the optimized design is shown below in terms of the time histories of the aircraft's motion in response to a 50 ft/sec vertical gust. The results show significant reductions in peak lateral acceleration and roll angle when compared with the initial design case. Similar reductions occur in the sideslip and yaw rate response for the same gust excitation.

It was previously assumed that the best way to improve the oblique wing's handling qualities was to minimize the aerodynamic couplings present in the design. The optimal solution for this design synthesis shows, however, that the aerodynamic coupling terms for the optimal design are nonzero. This is understandable because decoupled dynamic response requires that the aerodynamic and inertial couplings cancel each other. Only an integrated design procedure, which simultaneously analyzes the effects of configuration changes on the inertia and aerodynamics of the vehicle, is capable of solving for the configuration which maximizes the dynamic response decoupling.

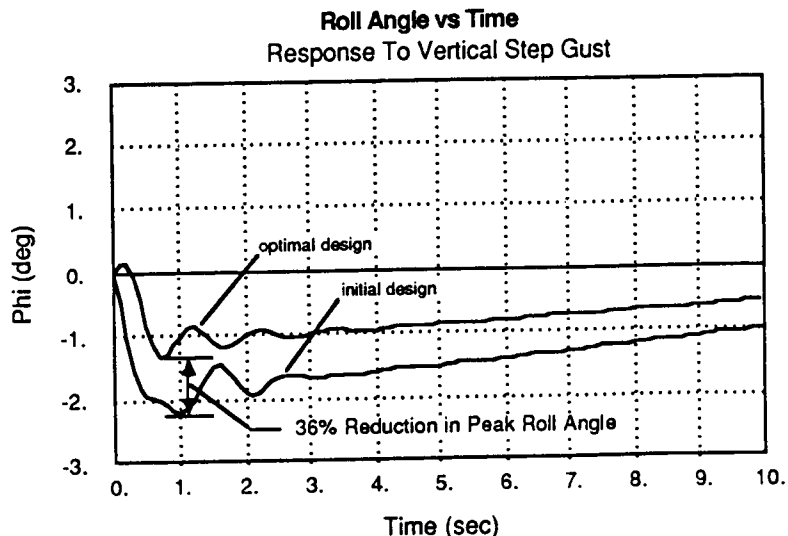
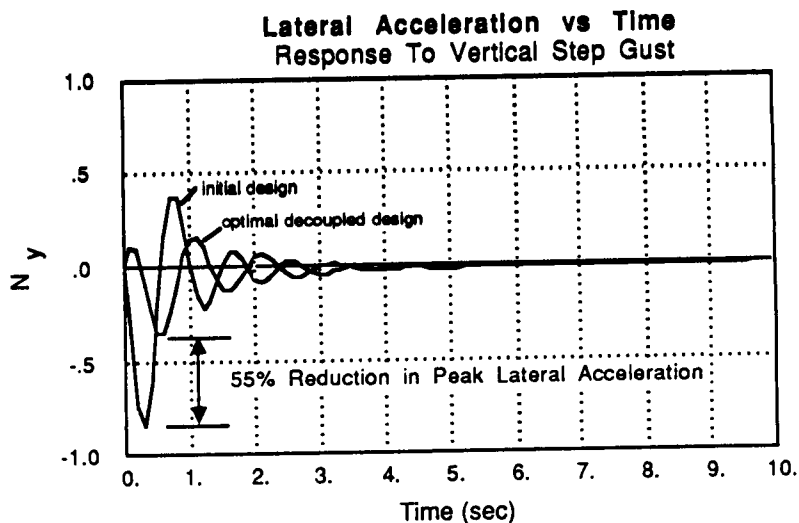



## SUMMARY AND CONCLUSIONS

The method described here for aircraft design optimization with dynamic response considerations provides an inexpensive means of integrating dynamics into aircraft preliminary design. By defining a dynamic performance index that can be added to a conventional objective function, a designer can investigate the trade-off between performance and handling (as measured by the vehicle's unforced response.) The procedure is formulated to permit the use of control system gains as design variables, but does not require full-state feedback. The examples discussed here show how such an approach can lead to significant improvements in the design as compared with the more common sequential design of system and control law.

## REFERENCES

1. Gill, P., Murray, W., Pitfield, R., "The Implementation of Two Revised Quasi-Newton Algorithms for Unconstrained Optimization," National Physical Laboratory Rpt. NAC 11, April 1972.
2. Zeiler, T., Weisshaar, T., "Integrated Aeroservoelastic Tailoring of Lifting Surfaces," *Journal of Aircraft*, Vol 25, No. 1, Jan. 1988, pp 76-83.
3. Sawaki, E., Kobayakawa, M., Imai, H., "A Design Method of an Aircraft with ACT by Nonlinear Optimization," *Trans. Japan Soc. of Aerospace Sciences*, Vol. 29, No. 85, Nov. 1986, pp 142-162.
4. Schweger, J., Sensburg, O., Berns, H., "Aeroelastic Problems and Structural Design of a Tailless CFC Sailplane," 2nd International Symposium on Aeroelasticity in Structural Dynamics, 1985.
5. Alag, G., Kempel, R., Pahle, J., "Decoupling Control Synthesis for an Oblique-Wing Aircraft," NASA TM 86801, June 1986.

- Method provides an inexpensive way of integrating dynamic performance considerations into aircraft preliminary design
- Composite performance index allows designers to investigate tradeoffs between handling and performance
- Control gains or configuration variables are selected simultaneously permitting reduced-order controllers
- Approach can yield increased performance compared with sequential design of configuration and control system