

NASA Technical Memorandum 102106

Advanced Methods for 3-D Inelastic Structural Analysis for Hot Engine Structures

(NASA-TM-102106) ADVANCED METHODS FOR 3-D
INELASTIC STRUCTURAL ANALYSIS FOR HOT ENGINE
STRUCTURES (NASA, Lewis Research Center)
12 p

CSCI 20K

N89-25490

G3/39

Unclass
0219564

C.C. Chamis
*Lewis Research Center
Cleveland, Ohio*

Prepared for the
2nd National Congress on Mechanics
sponsored by the Hellenic Society for Theoretical and Applied Mechanics
Athens, Greece, June 29—July 1, 1989

NASA

ADVANCED METHODS FOR THREE-DIMENSIONAL INELASTIC STRUCTURAL ANALYSIS
FOR HOT ENGINE STRUCTURES

C.C. Chamis*
National Aeronautics and Space Administration
Lewis Research Center
Cleveland, Ohio 44135

SUMMARY

Three-dimensional inelastic analysis methods are described. These methods have been incorporated into a series of new computer codes embodying a progression of mathematical models (mechanics of materials, specialty finite element, boundary element) for streamlined analysis of hot engine structures such as: (1) combustor liners, (2) turbine blades, and (3) turbine vanes. These models address the effects of high temperatures and thermal/mechanical loadings on the local (stress/strain) and global (dynamics, buckling) structural behavior of the three respective components. The methods and the three computer codes, referred to as MOMM (Mechanics of Materials Model), MHOST (MARC-Hot Section Technology), and BEST (Boundary Element Stress Technology), have been developed and are briefly described in this paper.

INTRODUCTION

Hot section durability problems appear in a variety of forms, ranging from oxidation/corrosion, erosion and distortion (creep deformations) to occurrence of fatigue cracking. Even modest changes in shape, from erosion or distortion of airfoils, for example, can lead to measurable performance deterioration that must be accurately predicted during propulsion system design to insure that long-term efficiency guarantees can be met. Larger distortions introduce serious problems such as hot spots and profile shifts resulting from diversion of cooling air, high vibratory stresses associated with loose turbine blade shrouds, difficult disassembly/reassembly of mating parts at overhaul, etc. These problems must be considered and efforts made to eliminate their effect during the engine design/development process. Initiation and propagation of fatigue cracks represents a direct threat to component structural integrity and must be thoroughly understood and accurately predicted to insure continued safe and efficient engine operation. To address the durability problems three-dimensional inelastic analysis methods/codes were developed as a part of the NASA Lewis Research Center Hot Section Technology program.

These methods/codes are based on function-specific theory in the sense that stress/strains and temperatures in generic modeling regions are specified functions of the spatial coordinates, and solution increments for load, temperature and/or time are extrapolated from previous information using the specified functions. The codes embodying the respective methods are referred to as MOMM (Mechanics of Materials Model), MHOST (MARC-Hot Section Technology), and BEST (Boundary Element Stress Technology). The codes are user friendly, stand alone, and transportable. Collectively these methods and their respective computer codes constitute recent advances in three-dimensional inelastic

*Senior Aerospace Scientist, Structures Division.

structural analysis for hot structures. The objective of the present paper is to summarize these methods/computer codes. Extensive details are described in NASA reports (refs. 1 to 5).

MECHANICS OF MATERIALS MODEL (MOMM)

The three-dimensional inelastic analysis in MOMM is based on intersecting networks of beams (fig. 1) which are modeled using nonlinear finite element methods. The theory is incorporated into a computer program following well-known finite element coding and solution procedures. The program calculates the total strain as a linear function of position in the cross section and along the length of the beam. Three material constitutive models are included in the code: the simplified material model, coupled viscoplastic material model, and the state-of-the-art material model. Static and transient analyses can be performed with applied loads, thermal loads, and enforced displacements. Frequencies and mode shapes using either initial or tangent stiffness are calculated; and buckling analysis is computed using initial or tangent stiffness.

Input parameters to the computer code consist of information defining the model itself and information describing the method of solution desired. The model is defined by nodal information which is internally discretized into beams (ref. 3). The element coordinate system of a given beam is defined by an orientation grid point, or vector. The geometry of a beam is rectangular in cross section, with the dimensions of the cross section along the element coordinate axes. The material properties are specified for each beam, including Young's modulus, Poisson's ratio, mass density, coefficient of thermal expansion, and yield stress. The initial temperature of the beam network is input, and the time at initial conditions is set to zero. A hardening slope for use with the simplified material model can be specified with zero slope representing, perfectly-plastic behavior. Boundary conditions are specified by indicating at each node a constrained or nonconstrained condition for the 6° of freedom allowed.

Representative results obtained using the MOMM computer code are compared with NASTRAN plane elements in figures 2 and 3. As can be seen the results show good agreement. MOMM has the advantage of including this non-linear methodology in only 10 300 FORTRAN statements.

SPECIALTY FINITE ELEMENTS

The specialty finite elements for performing three-dimensional inelastic analysis of hot section components are based on mixed finite element methods derivable from an augmented Hu-Washizu principle. These specialty finite elements are incorporated into a computer code MHOST. The code follows finite element programming procedures and is programmed using FORTRAN 77. The MHOST element capability is summarized in table I and the various solution algorithms are summarized in table II. The number of program lines is over 150 000.

Other unique features in MHOST are:

(1) Three different constitutive formulations for describing material behavior. They include secant elasticity (simplified plasticity) in which the material tangent is generated for use with Newton-Raphson type iterative algorithms, von Mises plasticity with the associated flow rule treated by using

the radial return algorithm, and the nonlinear viscoplastic model developed by Walker, in which an initial stress iteration using the elastic stiffness is utilized. A linear elasticity option is also included. The default is the conventional von Mises plasticity model. Anisotropic plasticity is handled by user supplied subroutines.

(2) Creep Effects. These are taken into account by integrating the time history in an explicit manner. An optional self-adaptive time step size control algorithm is also available.

(3) Duplicate Nodes. The continuity of stresses at nodal points can be broken by defining two nodal points at the same geometrical location and connecting them to enforce compatibility of displacements only. This is used to define the connections between generic modeling regions.

(4) Core Allocation. Core allocation is performed for the nodal and element quantities on the basis of maximum storage space requirements among the types of elements specified. All the element types must be specified here including those only appearing in the subelement regions.

(5) Global/Local Solution. The subelement iteration method is used to solve local stress concentration problems within the global solution. The code allocates the working storage for the subelement data in a hierarchical manner. The actual subelement mesh definition and the nodal and element-data storage allocation take place when the individual subelements are defined.

(6) Generic Modeling Regions (GMRS). Generic modeling regions are defined as collections of elements that model geometrically parametrized parts of hot section components. Multiple generic modeling regions in a given mesh are connected using the duplicate nodes. Different parameters are specified for each generic modeling region, and the input data can be prepared separately. Internally, the complex of the generic modeling regions is treated as a single mesh for the purpose of constructing and solving the finite element equations. A table is prepared to report results separately for each generic modeling region.

(7) Loubignac Iteration. Parameters for the numerical quadrature used in the mixed iterative processes are defined in a very precise way. Full integration, selective integration, or selective integration with filtering can be chosen for construction of the stiffness matrix. For residual vector integration, full and reduced integration can be selected. The strain integration can be performed either by using uniformly reduced integration, trapezoidal integration with the reduced shear strain approximation or the previous quadrature with the filtering option.

(8) Nodal Description. All the variables are defined and reported at nodal points. In the incremental processes, deformation and stress histories are integrated and stored only at the nodal points. Note that this architecture economizes storage substantially compared with fully integrated finite element displacement methods.

(9) Stress Boundary Conditions. Boundary conditions for stress can be specified by the user as an option, although no mathematical justification is

yet available for this type of constraint. Any stress component can be prescribed at any nodal point. Simple numerical tests have shown that inconsistent imposition of stress boundary conditions can lead to rapid divergence in the iterative process.

Typical results obtained by using the MHOST method/code are shown in figures 4 and 5. The local substructuring feature of MHOST for a stress concentration problem is shown in figure 6.

BOUNDARY ELEMENT METHODS

The boundary element method for three-dimensional nonlinear and transient problems was mainly developed during this research effort. The formulations required several break-throughs which are described in detail in references 1, 2 and 5. The methods developed are incorporated into a computer code BEST3D. Significant features of the method/code are briefly described below.

(1) Global Program Structure. The BEST3D code consists of a common input section, followed by three branches, for static, forced response and transient analysis. The static analysis branch is the model for the entire code, since the other branches largely employ generalized forms of the same algorithms used in the static analysis. The branch used for natural frequency/mode shape calculation is actually part of the static analysis loop.

The governing equations are discretized and assembled similar to finite element.

The assembled equations are solved to evaluate the unknowns, at boundary nodes for every increment of loading. The present formulation is similar to the variable stiffness approach used in the finite element method since the system matrix on the boundary as well as the right hand side vector is modified for each increment of loading.

(2) Particular Integrals. The particular integrals are used for the solution of problems with thermal loading, inhomogeneity and/or embedded holes or cracks. The solution algorithm is closely related to the algorithm for the determination of natural frequencies.

Following the calculation and storage of the coefficient matrices for both the boundary and interior stress equations, the displacements and tractions due to the particular solution are calculated. The full matrices containing the particular solution values are never stored, since the required multiplications with already existing boundary element matrices are carried out as the calculation proceeds. After the system matrix assembly, the weights used in the initial strain approximation are eliminated from the system, leading to a modified system matrix similar to that used in variable stiffness plasticity. This matrix is then decomposed and the remainder of the problem solved exactly.

(3) Extracation of Eigenvalues. The routine used is that for the solution of the generalized algebraic eigenvalue problem. It is especially suitable for the extraction of the largest few eigenvalues of a very large, very sparse system arising in the development of multigrid methods. Two processes, an iteration and a purification step can be used with this method. In order to

employ the algorithm in BEST3D it was necessary to reformulate it for the generalized eigenvalue problem and adapt it to the block storage used in BEST3D. Analogous methods are used for the solution of nonlinear dynamics and dynamic plasticity problems.

Representative results obtained by using the BEST3D methods/code to a nonlinear dynamic problem are shown in figure 7.

CONCLUSIONS

A research program is being conducted by NASA Lewis with the objective to develop three-dimensional inelastic structural analysis methods for hot structures. These methods are incorporated into a series of new computer codes embodying a progression of mathematical models (mechanics of materials, specialty finite element, boundary element) for streamline analysis of: (1) combustor liners, (2) turbine blades, and (3) turbine vanes. These models address the effects of high temperatures and thermal/mechanical loadings on the local (stress/strain) and global (dynamics, buckling) structural behavior of the three selected components. Three computer codes, developed and referred to as MOMM (Mechanics of Materials Model), MHOST (MARC-Hot Section Technology), and BEST (Boundary Element Stress Technology), are user friendly, stand alone and transportable. These are described in some detail and sample solution cases are included to illustrate significant features and versatility of the methods/codes. The methods and computer codes described in this paper constitute the only focused recent developments in advanced structural analysis for hot structures.

REFERENCES

1. Wilson, R.B.; Bak, M.J.; Nakazawa, S.; and Banerjee, P.K.: 3-D Inelastic Analysis Methods for Hot Section Components - First Annual Status Report, NASA CR-174700, 1984.
2. Wilson, R.B.; Bak, M.J.; Nakazawa, S.; and Banerjee, P.K.: 3-D Inelastic Analysis Methods for Hot Section Components - Second Annual Status Report, NASA CR-175060, 1986.
3. Meister, J.P.: Plate Analysis by the Framework Analogy. Master Thesis, The University of Akron, Department of Civil Engineering, Akron, Ohio, 1988.
4. Nakazawa, S.: 3-D Inelastic Analysis Methods for Hot Section Components, vol. 1, Special Finite Element Models, NASA CR-180893, 1988.
5. Wilson, R.; and Banerjee, P.K.: 3-D Inelastic Analysis Methods for Hot Section Components, vol. 2, Advanced Special Function Methods, NASA CR-179517, 1987.

TABLE 1. - MHOST SOLUTION CAPABILITY

Element definition options	Beam	Plane stress	Plane strain	Axi-symmetric solid	Three-dimensional solid	Three-dimensional shell
Linear isotropic elasticity	X	X	X	X	X	X
Anisotropic ^a elasticity		X	X	X	X	
Composite ^a laminate						X
Simplified plasticity		X	X	X	X	X
Elasto-plasticity		X	X	X	X	X
Unified creep-plasticity		X	X	X	X	X
Stress stiffening	X	X	X	X	X	X
Centrifugal mass	X	X	X	X	X	X
Thermal ^b strain	X	X	X	X	X	X
Creep ^b strain	X	X	X	X	X	X

^aApplicable only to linear elasticity.

^bNot applicable to the unified creep-plasticity in which the quantities are integrated as part of the model.

TABLE 2. - MHOST SOLUTION ALGORITHM LIBRARY

Analysis module option	Beam	Plane stress	Plane strain	Axi-symmetric solid	Three-dimensional solid	Three-dimensional shell
Quasi-static analysis	X	X	X	X	X	X
Buckling analysis	X	X	X	X	X	X
Modal analysis	X	X	X	X	X	X
Modal superposition	X	X	X	X	X	X
Transient dynamics	X	X	X	X	X	X

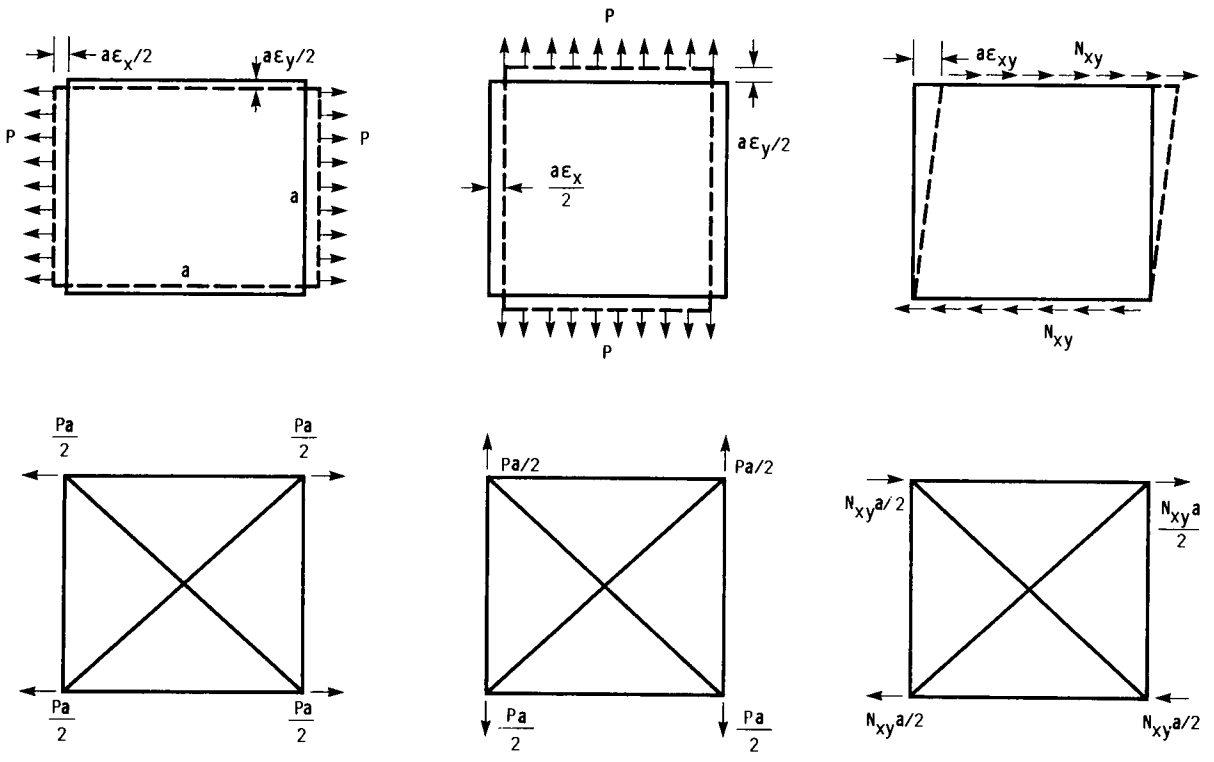
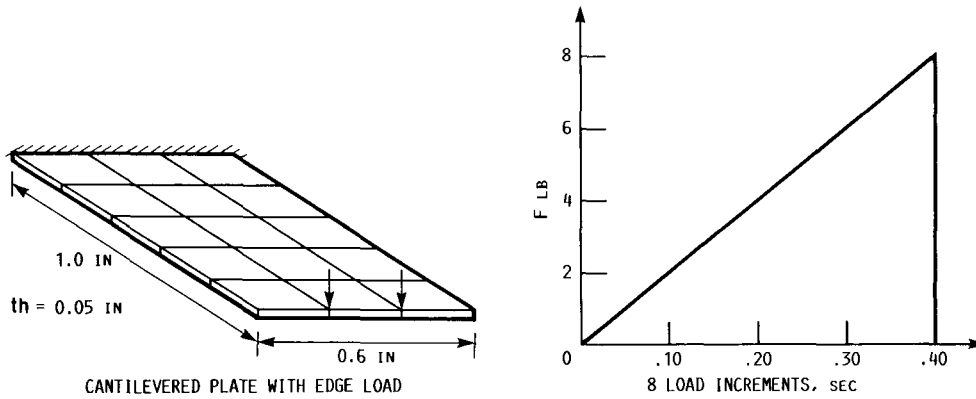

FIGURE 1. - PLATE AND FRAMEWORK CELL SUBJECT TO STATICALLY EQUIVALENT IN-PLANE FORCES.

	MAXIMUM DISPLACEMENT			MAXIMUM STRESS (psi)		
	MOMM	NASTRAN	PERCENT	MOMM	NASTRAN	PERCENT
	4.17×10^{-6}	3.83×10^{-6}	8.9	1.02×10^3	9.55×10^2	7.2
	1.70×10^{-4}	1.80×10^{-4}	-5.7	1.07×10^4	1.15×10^4	-7.4
	3.27×10^{-3}	3.22×10^{-3}	-1.5	2.00×10^4	2.11×10^4	-5.2
	1.15×10^{-2}	1.18×10^{-2}	-2.7	4.13×10^4	4.29×10^4	-3.7

PLATE DESCRIPTION: $L/w = 1.67$ $L/t = 40$ $E = 2.0 \text{ mpsi}$ $\nu = 0.3$

FIGURE 2. - MOMM ANALYSIS RESULTS AND COMPARISONS.



MOMM - SIMPLIFIED MATERIAL MODEL
 MOMM - ELASTIC-PLASTIC-CREEP MODEL
 MOMM - MODIFIED WALKERS MODEL
 MARC - MODIFIED WALKERS MODEL
 (4 NODE PLATE ELEMENT
 MOMM - SOURCE CODE 10300 LINES
 MARC - SOURCE CODE 150,000 LINES

LOAD HISTORY

CPU TIME	MAX. DISPL. IN
29 SEC	.0309
35 SEC	.0351
73 SEC	.0361
47 SEC	.0376

FIGURE 3. - MOMM CPU TIME COMPARISON.

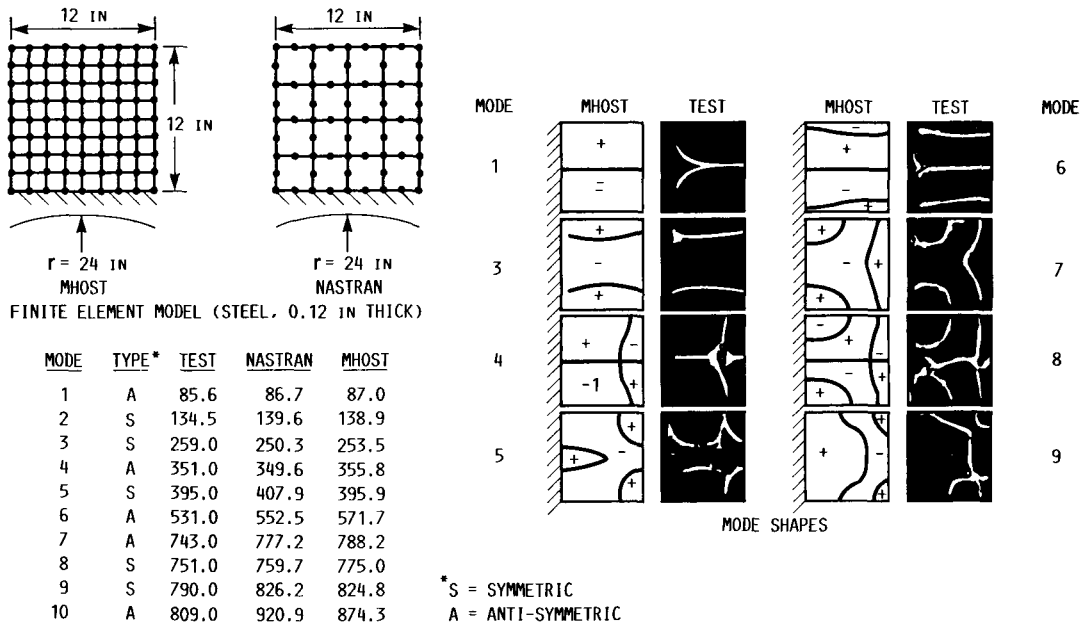

FIGURE 4. - MHOST VIBRATION ANALYSIS/COMPARISONS.

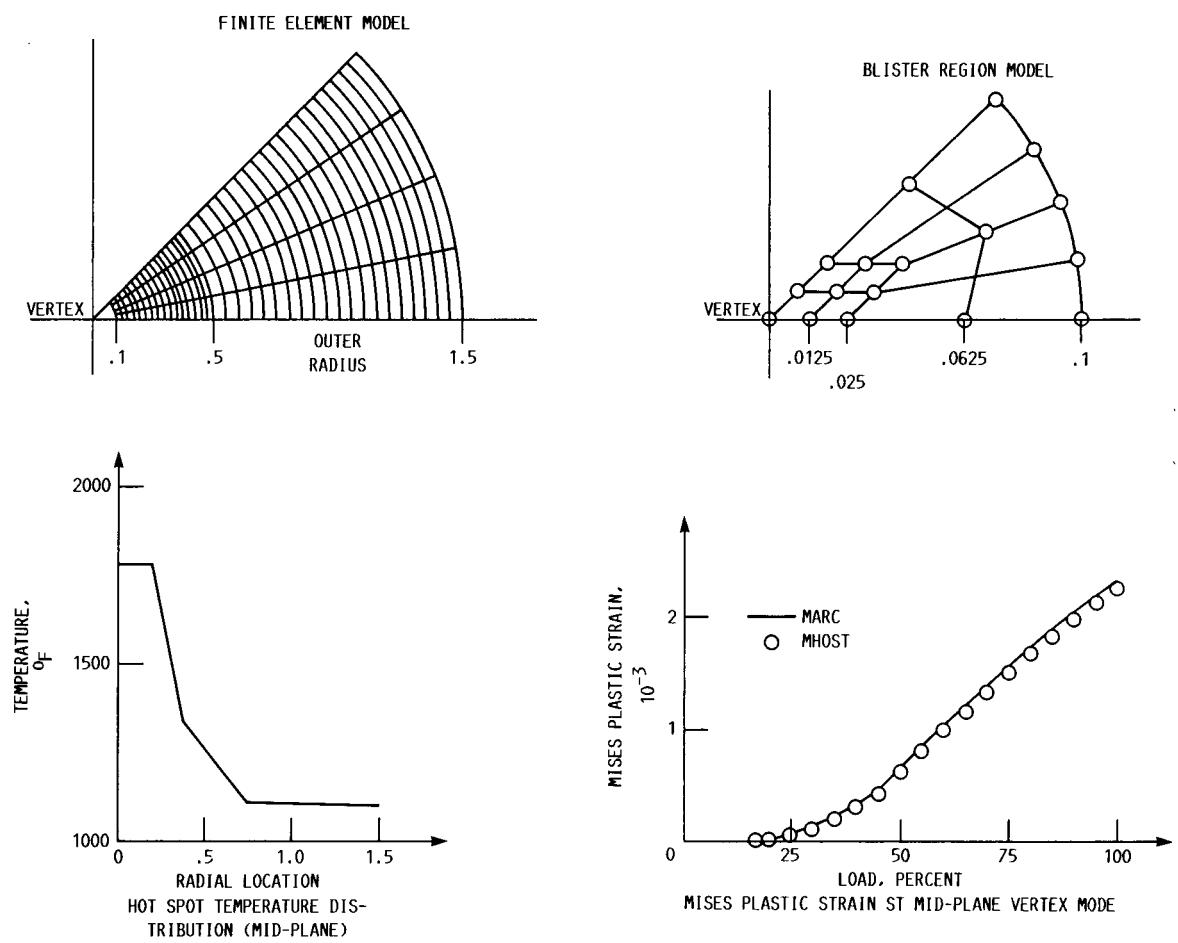

FIGURE 5. - BURNER BLISTER MHOST ANALYSIS. -

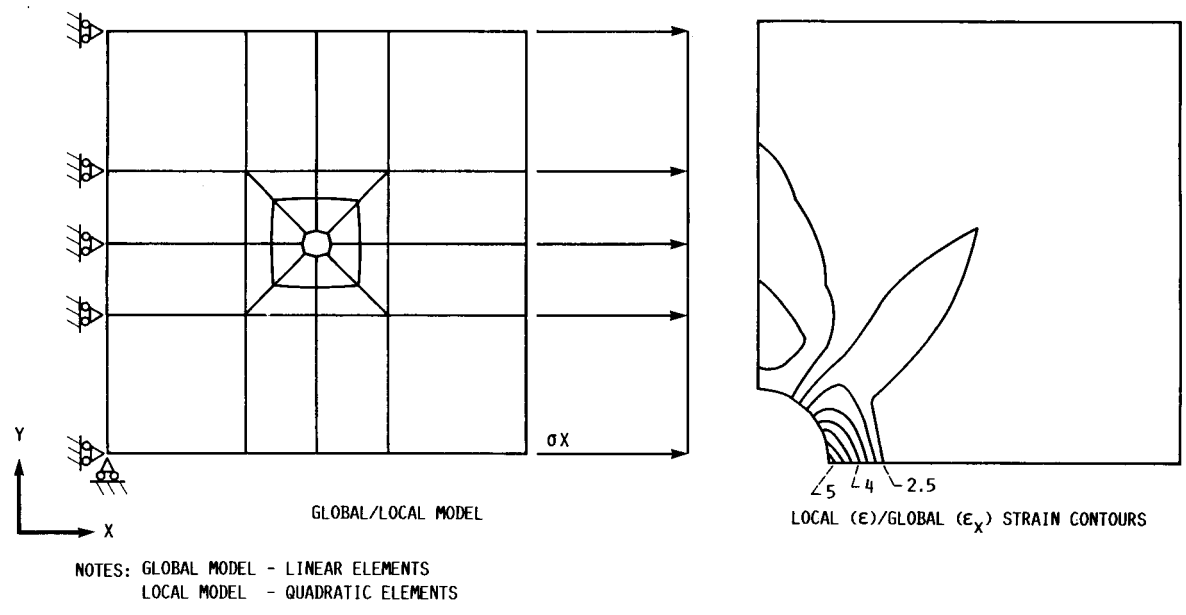

FIGURE 6. - MHOST ILLUSTRATIVE EXAMPLE OF VERSATILE GLOBAL/LOCAL ANALYSIS CAPABILITIES FOR INELASTIC STRESS CONCENTRATION PROBLEMS.

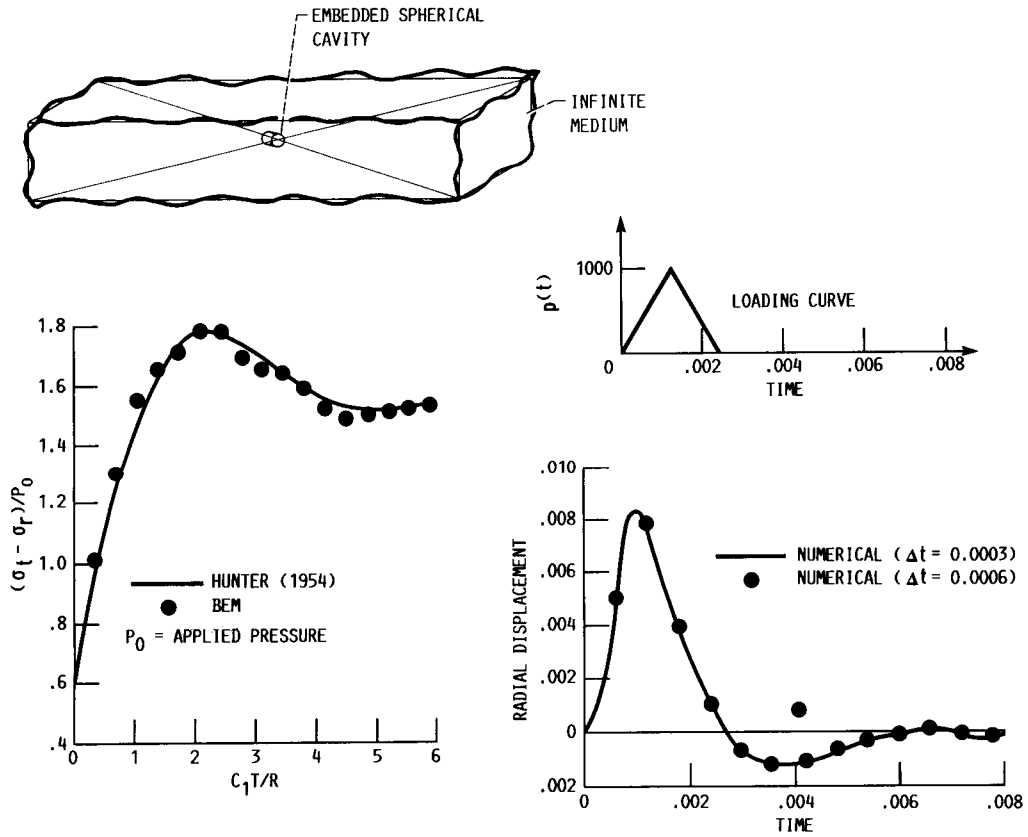

FIGURE 7. - BEST 3D DYNAMIC (TRANSIENT) ANALYSIS RESULTS SPHERICAL CAVITY IN INFINITE MEDIUM SUBJECTED TO DYNAMIC PRESSURE.



National Aeronautics and
Space Administration

Report Documentation Page

1. Report No. NASA TM-102106		2. Government Accession No.		3. Recipient's Catalog No.	
4. Title and Subtitle Advanced Methods for 3-D Inelastic Structural Analysis for Hot Engine Structures				5. Report Date	
				6. Performing Organization Code	
7. Author(s) C.C. Chamis				8. Performing Organization Report No. E-4873	
				10. Work Unit No. 505-63-11	
9. Performing Organization Name and Address National Aeronautics and Space Administration Lewis Research Center Cleveland, Ohio 44135-3191				11. Contract or Grant No.	
				13. Type of Report and Period Covered Technical Memorandum	
12. Sponsoring Agency Name and Address National Aeronautics and Space Administration Washington, D.C. 20546-0001				14. Sponsoring Agency Code	
15. Supplementary Notes Prepared for the 2nd National Congress on Mechanics sponsored by the Hellenic Society for Theoretical and Applied Mechanics, Athens, Greece, June 29—July 1, 1989. Invited key lecture.					
16. Abstract Three-dimensional Inelastic Analysis Methods are described. These methods have been incorporated into a series of new computer codes embodying a progression of mathematical models (mechanics of materials, specialty finite element, boundary element) for streamlined analysis of hot engine structures such as: (1) combustor liners, (2) turbine blades, and (3) turbine vanes. These models address the effects of high temperatures and thermal/mechanical loadings on the local (stress/strain) and global (displacements, frequencies, amplitudes, buckling) structural behavior of the three respective components. The methods and the three computer codes, referred to as MOMM (Mechanics of Materials Model), MHOST (MARC-Hot Section Technology), and BEST3D (Boundary Element Stress Technology), have been developed and are briefly described in this paper.					
17. Key Words (Suggested by Author(s)) Approximate methods; Mixed finite elements; Boundary elements; Computer codes; Sample problems			18. Distribution Statement Unclassified—Unlimited Subject Category 39		
19. Security Classif. (of this report) Unclassified		20. Security Classif. (of this page) Unclassified		21. No of pages 20	22. Price* A03