

70

188132

An Optical Processor for Object Recognition and Tracking

J. Sloan and S. Udomkesmalee
Perkin-Elmer Corporation
Garden Grove, CA 92641

PR 633322

1. Abstract

This paper describes the design and development of a miniaturized optical processor that performs real time image correlation. The optical correlator utilizes the Vander Lugt matched spatial filter technique. The correlation output, a focused beam of light, is imaged onto a CMOS photodetector array. In addition to performing target recognition, the device also tracks the target. The hardware, composed of optical and electro-optical components, occupies only 590 cm^3 of volume. A complete correlator system would also include an input imaging lens. This optical processing system is compact, rugged, requires only 3.5 watts of operating power, and weighs less than 3 kg. It represents a major achievement in miniaturizing optical processors. When considered as a special-purpose processing unit, it is an attractive alternative to conventional digital image recognition processing. It is conceivable that the combined technology of both optical and digital processing could result in a very advanced robot vision system.

2. Introduction

Coherent optical correlators have been successfully used in pattern recognition for years [1]. These correlators work on the familiar optical reconstruction property of holograms. The holograms are called Vander Lugt matched filters. A hologram of the target is made by simultaneously exposing the film plate to a reference beam and the 2-dimensional fourier transform of that target. Later, when the 2-dimensional fourier transform of a scene containing the target is imaged onto the hologram, it selectively re-directs the target's energy into a reconstructed reference beam which is focused onto a detector (see Fig. 1). The detector will see a "correlation spot" for every target in the scene, at a location that corresponds to that target's direction. The rest of the scene does not correlate, and appears essentially blank. This is an ideal format for position detection and video tracking.

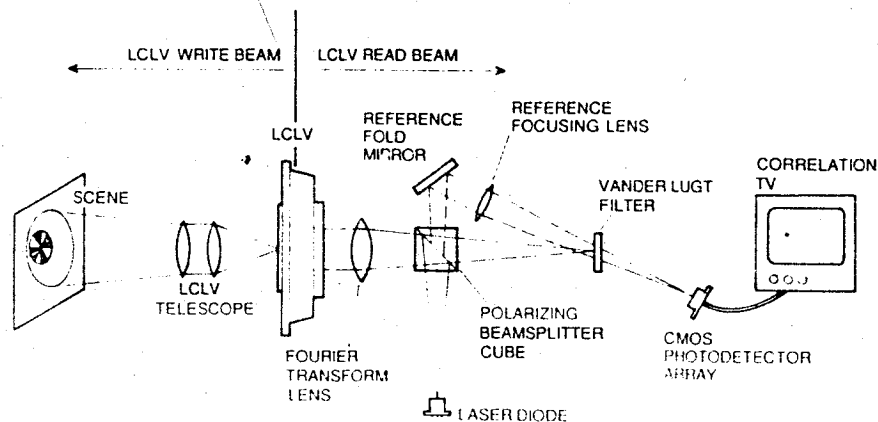

Fig. 1. The layout of the Solid Block Correlator. The correlator does not have a reference beam. When a target is correlated, the hologram reconstructs this beam, which was present in the HeNe system used to expose the hologram. The hologram focuses it onto a detector as a correlation spot.

The operation of optical correlators utilizing Vander Lugt matched spatial filters has thus far been primarily restricted to laboratory environments. In order to fully employ such correlators in real-world situations they need to be redesigned to survive field conditions, and deal with varying scene illuminations and realistic fields of view [2]. This paper presents the design and development of a miniaturized correlator that addresses these problems, and offers some future applications to which it is well suited.

The Perkin-Elmer Corp. has recently built the first of three optical correlation systems small enough to be gimballed inside a 150mm diameter missile (see Fig. 2). This Miniature Correlation Seeker System (MCSS) has been developed under contract to the Army's Missile Command (MICOM) to specifically demonstrate that an optical processor can be built rugged enough to operate inside a missile, and home it in on a pre-determined target. The correlator uses a Hughes Aircraft Co. Liquid Crystal Light Valve (LCLV) to convert the incoherent scene that the missile views to a coherent version suitable for optical processing by a Vander Lugt matched filter. The ability to immediately recognize and track a pre-selected target makes this system a viable option for navigation and guidance, docking maneuvers, robotic vision, and triangulation applications.

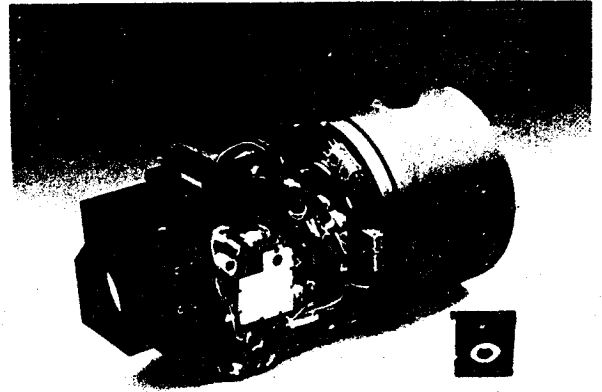

Fig. 2. Photograph of the Miniaturized Correlation Seeker Head, and a target's hologram.

3. The Miniature Correlator Seeker System

The MCSS contains four key components: the Hughes LCLV, the Solid Block Correlator (SBC) module, the hologram, and a high-performance two-axis stabilized imaging platform.

The LCLV

The Hughes device is a hybrid field effect light valve utilizing the birefringence of the liquid crystal molecules, and their orientation, to modulate the polarization of the read light beam (see Fig. 3) [1]. The light valve is sensitive over a very narrow wavelength band on its write side ($\lambda = 520\text{nm} \pm 20\text{nm}$), and over a slightly broader band encompassing $\lambda = 780\text{nm}$, for reading. The difference in wavelengths, along with an internal light-blocking layer, effectively eliminates crosstalk between the two beams.

During operation of the light valve, an incoherent scene containing the target is imaged onto the write side of the LCLV with a telephoto lens. The variations in scene intensity locally alter the electric field permeating the liquid crystal layer which overlays the mirror on the LCLV's read side. The disturbed electric field changes the orientation of the liquid crystal molecules, thereby creating local rotations of the polarization of the read beam as it enters and exits the liquid crystal layer. Thus, the LCLV imprints an incoherent scene's intensities as rotations of the polarization of the independent read beam.

The SBC Module

The SBC module, so called because the optical path is confined inside a folded glass prism assembly, fits in a cylindrical housing 100mm in diameter and 75mm high. The prism assembly is roughly octagonal in shape, and about 88mm across the corners (see Fig. 4). This solid configuration eliminates mounting problems, guarantees mirrors of good figure, and is easy to fabricate since all but two prism angles are 45° . Most importantly, alignments are permanent because the prism assembly is cemented together. Once the hologram is kinematically registered, it too is potted in place. The prism assembly rides piggyback on the LCLV. A coherent light source, fourier transform lens, hologram correlation spot detector, and input imaging system for the LCLV complete the package (see Fig. 5).

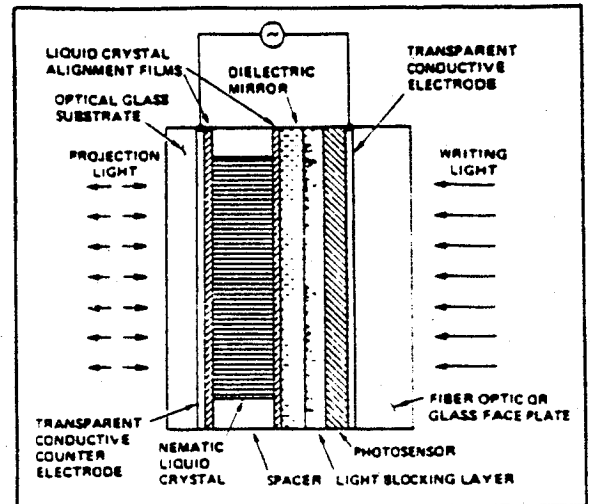

Fig. 3. A cross-section of the Hughes Liquid Crystal Light Valve. The liquid crystal molecules are aligned in a bias AC electric field. When a scene is imaged onto the write side, the electric field changes, and re-orientates the liquid crystal molecules. This locally alters the degree of rotation applied by the molecules to the polarized read laser beam. Thus, write image intensities are converted to varying polarizations in a separate read beam. (Courtesy of Hughes)

A 30mW laser diode ($\lambda = 780\text{nm}$) is the coherent light source. Its polarized beam is apertured to reduce scattered light from its fan-shaped output. Spatial filtering is not required. A polarizing beam-splitter cube reflects the laser beam into the prism assembly. The beam is internally reflected around one half of the prism assembly by its 45° corners, and exits perpendicularly through the center of the assembly via a dove prism. There, a 2-element lens of 160mm focal length collimates the beam, which strikes the LCLV on its read side. The useful diameter of this read beam is 12mm. The LCLV modulates the polarization of the read beam according to the scene imaged on its write side. The reflected read beam then retraces its path through the collimating lens, which now acts as a fourier transform lens, and continues backwards through the prism assembly to the polarizing beam-splitter cube. Light that was not rotated by the LCLV is reflected back towards the laser diode. The rotated portions are transmitted by the beam-splitter cube to the hologram.

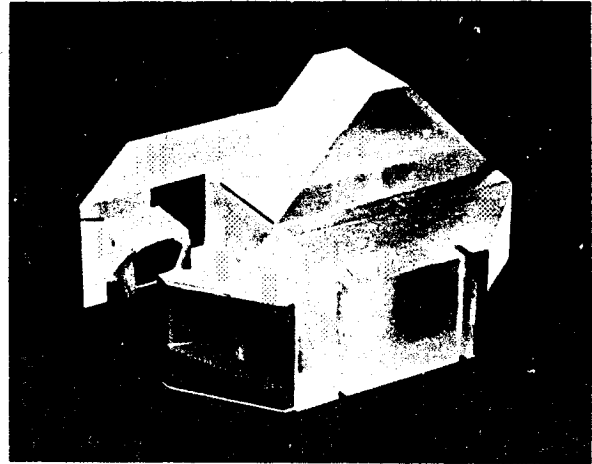

Fig. 4. Photograph of the Solid Block Correlator prism assembly. The prism assembly is 88mm across the corners.

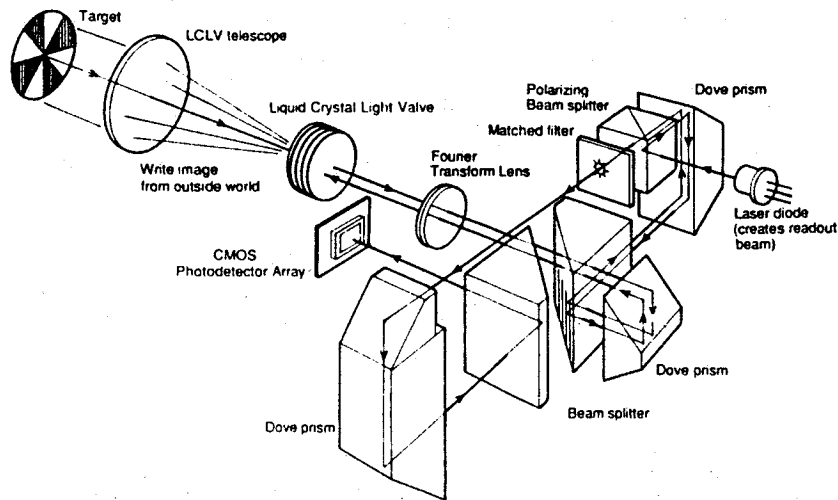

Fig. 5. Exploded view of the Solid Block Correlator module. The LCLV converts an incoherent white light scene into a version suitable for coherent optical processing. The fourier transform of this image is focused onto the Vander Lugt matched filter (hologram). If correlation occurs, the beam continues to the detector, a CMOS photodetector array, and appears as a focused spot. The location of the spot corresponds to the direction to the identified target.

The Hologram

The hologram of the target acts as both a Vander Lugt matched filter, and a holographic lens. A target's "matched" energy is diffracted and focused through the second half of the prism assembly to a detector, in this case a CMOS photodetector array. A target's correlation appears as a focused spot on the array at a position corresponding to the target's direction. If more than one target is in view at once, the correlator identifies and locates them simultaneously. With multiple exposures, the hologram becomes a multiplexed matched filter, capable of recognizing more than one view, scale, or type of target. The level of multiplexing depends on the method used. Overlaid holograms suffer from reduced efficiency, while separated holograms require multiple optical paths [3].

By using a laser diode, the SBC module is kept small. However, the photographic emulsion (Kodak 131-02) is not very sensitive at $\lambda = 780\text{nm}$, and a separate correlator system operating with a HeNe laser ($\lambda = 633\text{nm}$) is used to expose the holograms. (The laser diode can expose the film, given a long enough exposure, and this ability is used to great advantage to align the position of the hologram to the SBC's optical axis. The hologram's alignment is accurate to within a micron.) The HeNe system is precisely aberrated to compensate for the change in operating wavelengths, and is aligned to match the SBC's optical axis. A transparency of the selected target is placed in the collimated object beam, and its 2-dimensional fourier transform, properly scaled, is imaged onto the 13mm diameter film plate. A reference beam, brought to a focus behind the film plate, is also required. This beam is the one reconstructed when the hologram finds a target correlation.

The ratio of intensities between the object and reference beams determines what details of the target will be used for correlation. To get high diffraction efficiency in a hologram, the local intensity in both beams should be equal at the film plane. When these two beams meet and interfere, fringes are formed in the film's emulsion. These create a diffraction grating at the locations of energy in the target's 2-dimensional fourier transform, or power spectrum. Very intense spatial frequencies in a target's power spectrum will over-expose the hologram, whereas very weak spatial frequencies will fail to interfere with the reference beam and won't produce fringes. Thus, only a restricted range of power spectrum intensities of a target can be adequately matched by the reference beam at any one exposure (see Fig. 6). For a target with a wide range of spatial frequencies, a determination of what features to use for correlation must be made, in keeping with the film's limitations.

Once the discriminating feature size is determined, the focal length of the LCLV's imaging system can be found. The correlating features must be magnified enough to be resolved by the LCLV. The MTF of the Hughes device extends out to 35 lp/mm, with 50% MTF around 20 lp/mm. The MCSS uses a 128mm f/4 lens system to image scenes onto the LCLV. This short focal length was in part determined by space restrictions inside the MICOM test missile, and a required field of view and field of regard.

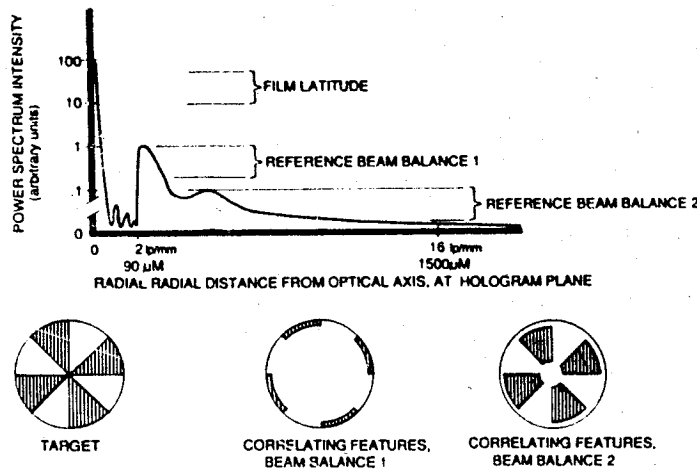

Fig. 6. A target, bottom left, and its power spectrum, top. The film's exposure latitude limits the range of intensities that the reference beam can match. If beam balance 1 is used, the filter will correlate against low frequency features, bottom middle. If beam balance 2 is used, mid-frequency features will correlate, bottom right. Beam balances must be chosen to correlate only on a target's distinguishing features, and yet be as generic as possible to accommodate different scales, angles of view, and changing aspect ratios.

The Stabilized Platform

While the resolution of the LCLV is not affected by the write light intensity, its time response is highly dependent. Low write light levels ($30\mu\text{W}/\text{cm}^2$ at $\lambda = 520\text{nm}$) result in slow (≥ 150 msec) rise or fall times depending on the driving frequency used to operate the light valve [1,4]. This makes it necessary to stabilize the input image on the LCLV. Even slight image motion will suppress fine detail or faint targets, rendering them invisible to the correlator. Until more responsive devices with the same resolution capability become available, a stabilized platform will be a required adjunct for a dynamic optical correlator using a LCLV. An improved light valve could reduce the size of the MCSS to only 100mm in diameter and 200mm long. When mounted in a two-axis gimbal, the system becomes 150mm in diameter and 350mm in length. In order to keep the imaging platform aligned with the line-of-sight, rate integrating gyroscopes are mounted on each gimbal axis. These are coupled to a motor on the gimbal system such that a line-of-sight error command from a video tracker moves the platform at a rate proportional to the line-of-sight rate. The gimbal system has a pointing repeatability of 0.3 mrad, and a jitter stability of 10 μrad .

4. Missile Application

Presently, the MCSS will be used in a U.S. Army test program. It is a test of hardware concept only. The correlator will be mounted inside a missile, and perform target recognition as well as provide a guidance signal to direct the missile to its target. The missile is launched from a helicopter flying at an altitude of 5000 feet (see Fig. 7). The video tracker and guidance control computer are located at a ground command station and communicate with the missile via radio-frequency transmission channels. (The ground station is a hold-over from previous test programs. It would be possible to incorporate a guidance module in the missile, making the system completely autonomous.) When the target has been recognized (correlated), the missile is dropped from its carrier, but retains communication with the carrier through a fiber optic link. By continuously monitoring the rate integrating gyros, guidance information pertaining to the bearing of the line-of-sight can be directly obtained. Line-of-sight rates are transmitted to the missile steering system to maintain a constant-bearing course. The video tracker locates the correlation spot in the TV field by finding the peak pixel intensity. Correlation spot position errors are also transmitted to the rate integrating gyroscopes, enabling the seeker to track the target (see Fig. 8).

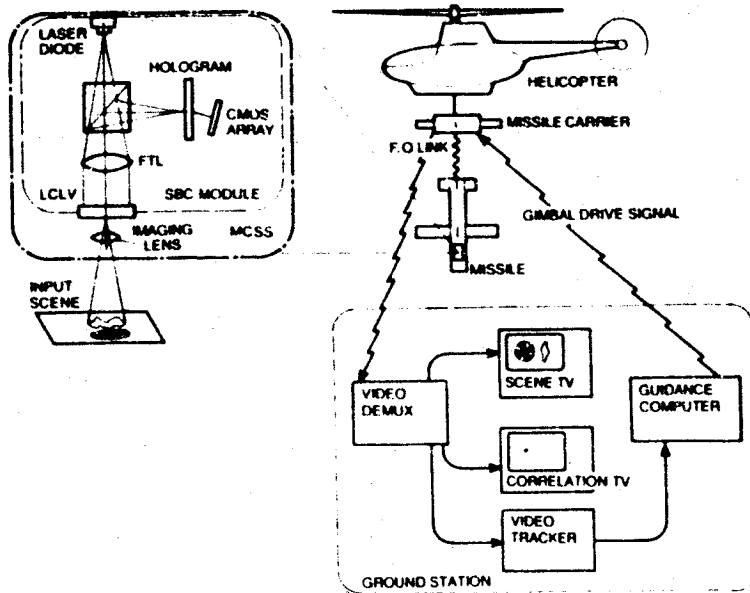

Fig. 7. A schematic view of the Army test program using the MCSS. The MCSS is installed in the front of the missile and will identify and track a specific target. Guidance commands will be generated from a ground control station, based on the information generated by the optical correlator.

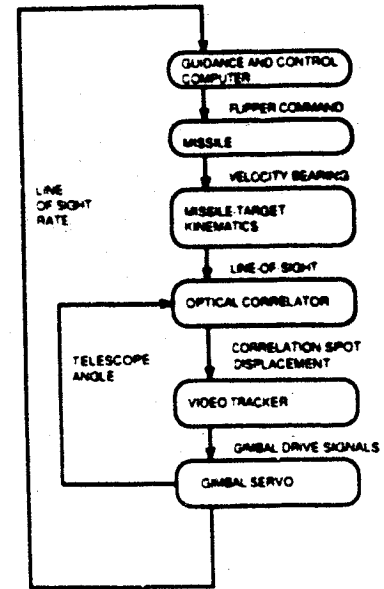

Fig. 8. A flow chart of the guidance loop used in the missile tests. The optical correlator allows the missile to find its own target without assistance from an operator.

5. Targets

In the Army's test program, the MCSS must track an approaching target over a 10:1 zoom ratio. This means that the spatial frequencies of the target also change scale by a factor of ten. A simple matched filter cannot correlate over this range unless some feature of the target is "invariant", i.e. unchanging in the spatial frequency domain. This includes not only the distance from the DC zero frequency, but the angular orientation too. For this reason, a special target is used. The MCSS uses a "cooperative" target which has this property. The target is a circle divided into 10° wedges, with 18 black sectors alternating with 18 white ones (see Fig. 9). As the target approaches the correlator, some mid-frequency detail will shrink out of the hologram's correlating zone while a higher frequency detail shrinks into that same zone. There is always some portion of the target that precisely matches the required correlation features. Additionally, a rotation of 10° has the effect of returning the pattern to its original orientation.

Unfortunately, a rotation of 5° is sufficient to displace the target's power spectrum at the hologram plane from the diffracting fringes, and correlation will not occur. This is remedied by double exposing the hologram so the correlator recognizes the original pattern as well as one rotated by 5° . In this manner, the "cooperative" target avoids the two problems of scale and orientation that plague optical correlators. (Instead of doubly exposing the hologram, the target could have twice the number of sectors. Now, a rotation of 5° restores the pattern to its original orientation and correlation is continuous throughout the rotation. However, this finer pattern would necessitate twice the magnification to the LCLV. This is impractical for the MCSS since the LCLV telescope is restricted by missile size. A minimum target image area is necessary to provide the SBC with enough reflected laser energy to correlate. The small image scale, coupled with the insensitivity of the LCLV, has already forced the target size to 10.66m in diameter.)

The determination of optimum feature size for discrimination was found by experiment. The requirement for correlation at 5000 feet altitude meant the hologram had to be capable of correlating on fine detail. In this case, the hologram filter generator system was outfitted with a target

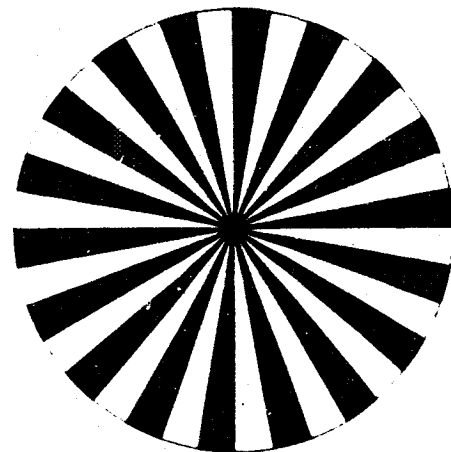

Fig. 9. The "cooperative" target used in the MICOM test program. This target is scale and orientation invariant, so it is easily correlated over a wide range of distances, and orientations.

transparency representing the angular subtense of the real target as viewed from 1/3 the maximum correlation distance. This is close to the geometric mean of the target's subtense over a correlation run. It represents a compromise of many parameters: energy available for correlation at maximum range (laser diode power per solid angle times the target image size on the LCLV times the sensitivity of the LCLV), emulsion exposure latitude, power spectrum energy per hologram area, number of correlating features of the target, and the quality of the generator's optical system. This compromise changes for different targets, including different views of the same object.

6. Future Space Applications

Although the difficulties in designing a scale and rotation insensitive optical correlator are not addressed in this paper, the MCSS can still perform useful machine sensing and perception functions. It can be used for object identification, docking maneuvers, and robotics, and is small enough to be used as a field unit. The correlator reduces a complex scene to a black background with a correlation spot, perfect for tracking computers and position analysis. There are some advantages to using "cooperative" targets instead of specific targets however.

A spacecraft with one "cooperative" target provides identification and directional information only (see Fig. 10). Two targets on a craft provides a twin spot correlation whose separation gives target distance information too. An asymmetric array of three targets provides relative angular orientation in addition. The same correlator can be used for any craft that carries the same cooperative target or target array. Targets can be used to guide a robot vehicle home as well. Multiple correlators can be used for accurate triangulation networks. In the current configuration, the MCSS can point to an accuracy of 0.2 mrad, as defined by the correlation CMOS photodetector pixel size. With pixel averaging, this can be improved significantly. These same principles can be used to guide a robot's arm to an object and pick it up. Targets need to be well illuminated, but not entirely visible to the correlator. With increased LCLV image scaling, target size can be markedly reduced, or detection range increased.

7. Future Correlators

The SBC has limited "intelligence" in that it can only recognize those targets stored in its matched filter, some or all of which may be of the same object as viewed from different distances or directions. Experiments indicate that a maximum of about 30 targets can be stored on a 1 cm² hologram [3]. An additional handicap is the requirement that SBC holograms be made in a separate precision optical system. The future of the SBC lies in the incorporation of a larger target "memory", preferably one that can be actively manipulated and easily expanded.

One way to accomplish this would be to substitute a Programmable Spatial Light Modulator (PSLM) for the holographic matched filter. With a built-in EPROM of power spectra for various targets, and software to scale and rotate them, the SBC would become a much more versatile processor. A candidate PSLM is the Sight-Mod, a magneto-optical device manufactured by Semetex Inc. It uses core memory addressing to magnetically flip pixels from one optical polarity to another. An external analyzer converts the two states to transmissive or opaque (see Fig. 11). The erase/re-write cycle for the entire array is only a few milliseconds, and the array's state is non-volatile. Current devices have arrays of 128 x 128 pixels, with a pixel size of 76µm square. This coarse array would require a much longer focal length transform lens to scale the power spectrum to the large pixel size. A 3rd generation version with a 256 x 256 pixel array is in development. The Semetex package is relatively huge compared to the hologram in the SBC, with a size of 150mm x 150mm x 50mm thick.

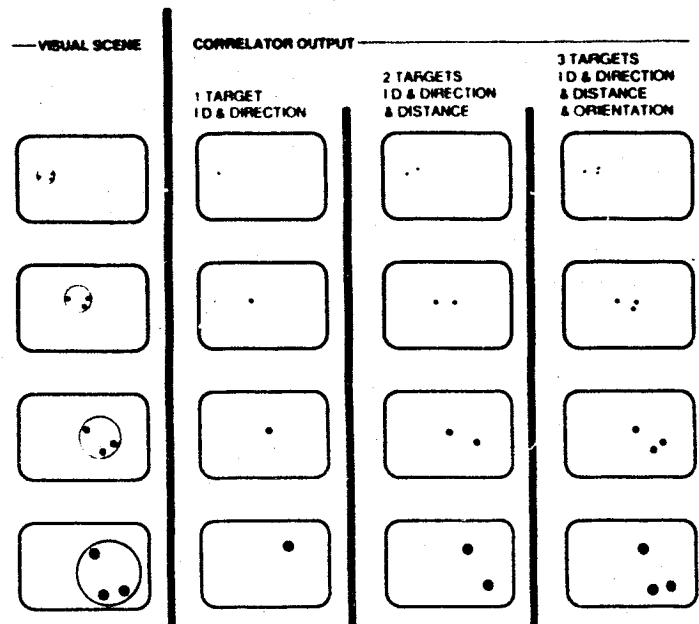

Fig. 10. Arrays of targets provide more information than single targets. A spacecraft, or single target, can be identified and tracked. Two targets will also yield distance data, and three will unambiguously resolve relative orientations.

Initial studies with the Sight-Mod have shown that it can perform simple optical processing [5]. More work is needed to explore its capabilities and limitations as a PSLM. The Semetex device is not the only one to consider, but the others also suffer from poor resolution or slow response times. There is no ideal PSLM yet, but the area is being actively researched. If progress follows the integrated circuit field, within a few years these devices will operate twice as fast, have twice the resolving capability, and use less power.

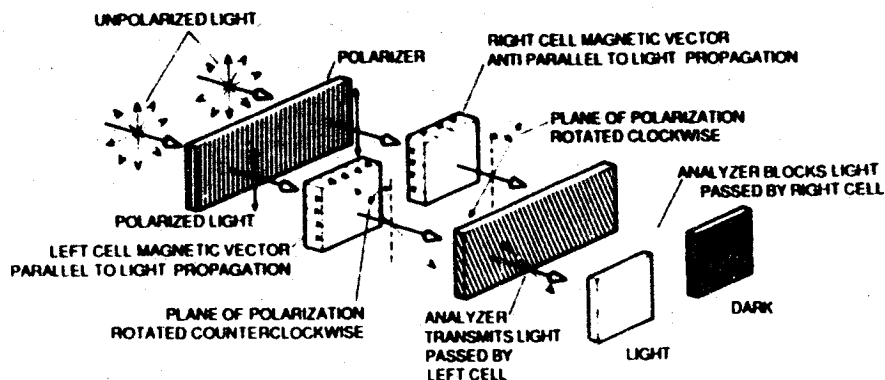

Fig. 11. Operation of the SIGHT-MOD as a light valve. Signals to the SIGHT-MOD array change the magnetic orientation of each pixel. Light passing through all of the "on" pixels is projected onto a display surface to create an image or character. (Courtesy of Semetex)

8. Conclusion

The miniaturization of a coherent optical correlator is an important achievement. It dismisses the idea that optical computers consist of a roomful of sensitively aligned optics and shows that they can be redesigned into rugged, independent units. The present missile application of this device demonstrates the feasibility of adapting image correlation technology towards real-world problems, but does not demonstrate the full potential. Scale and orientation changes severely limit the versatility of current optical processors. More work is needed to increase the memory capability of matched filters. The next generation of optical correlators may solve this problem with an electrically programmed hologram that has an easily manipulated and expandable memory of target spectra and quick time response.

Nevertheless, the SBC has immediate application opportunities in space and robotics. By using an array of three asymmetrically placed "cooperative" targets, information pertaining to identity, direction, distance, and orientation can be derived. Such capabilities are crucial for designing an autonomous robot system. Experience in using the correlator module in guidance and navigational applications, or robot vision systems, will prove invaluable for the design of future optical correlators.

9. References

- [1] W. Bleha, et al., *Opt. Eng.*, 17, 4, (1978)
- [2] J. Duthie, J. Upatneiks, C. Christensen, R. McKenzie Jr., *Proc SPIE* 231, (1980)
- [3] K. Leib, R. Bondurant, S. Hsiao, R. Wohlers, R. Herold, *App. Opt.*, 17, 18, (1978)
- [4] R. Buzzard, J. Sloan, *Proc. SPIE*, 684, (1986)
- [5] D. Psaltis, F. Mok, E. Paek, *Proc. SPIE*, 465 (1984)