

34-51
188202
108

Model Reduction for Discrete Bilinear Systems

A.M. King and R.E. Skelton
Purdue University
West Lafayette, IN 47907

P9391092
= actu

1. Abstract

A model reduction method for discrete bilinear systems is developed which matches q sets of Volterra and covariance parameters. These parameters are shown to represent both deterministic and stochastic attributes of the discrete bilinear system. A reduced order model which matches these q sets of parameters is defined to be a q -Volterra covariance equivalent realization (q -Volterra COVER). An algorithm is presented which constructs a class of q -Volterra COVERS parameterized by solutions to a Hermitian, quadratic, matrix equation. The algorithm is applied to a bilinear model of a robot manipulator.

2. Introduction

While model reduction of linear systems has been extensively researched over the past few years, little work has been done in the area of model reduction for nonlinear systems. One class of nonlinear systems which is especially appealing are bilinear systems ([1]-[4]). Bilinear systems are linear in the state variables, linear in the control variables, but nonlinear in the state and control. One reason that this class is of interest is that nonlinear systems which are linear in the control variables can be accurately approximated by bilinear models ([5],[6]). Bilinear approximations will in general have a higher order than the original nonlinear system and effective means for reducing bilinear models are needed.

Most approaches to model reduction of linear systems have strived to preserve or approximate a certain characterizing property of the full order model. For deterministic systems this property is typically the impulse response sequence or the system Hankel matrix (e.g., [7]-[10]). Model reduction of linear stochastic systems usually involves the output covariance sequence or the corresponding Hankel matrix (e.g., [11] and [12]). A model reduction technique which considers both deterministic and stochastic properties has also been developed ([13]-[15]) and the resulting reduced order models have been called q Markov COVERS (covariance equivalent realizations). The model reduction problem for discrete bilinear systems has recently received some attention. Hsu et al. [16] develop a method for deterministic, discrete, bilinear systems using a generalized Hankel matrix. Desai has proposed an approach to stochastic model reduction based on his realization theory ([17]).

In this paper we develop a model reduction algorithm analogous to the q Markov covariance equivalent realization approach for linear systems. The algorithm produces a class of reduced order models which exactly match a specified number of deterministic and stochastic parameters. This class of reduced order models is parameterized by the solutions to a Hermitian, quadratic, matrix equation. Section 3 presents the deterministic and stochastic attributes of a bilinear system which we will preserve in our method and defines a q -Volterra covariance equivalent realization. Next, in section 4 the model reduction algorithm is outlined. In section 5 a parameterization of reduced order models which match q Volterra parameters and q covariance parameters is formulated. Section 6 contains an application of the proposed algorithm to a two degree of freedom robot manipulator. The final sections are our concluding remarks, acknowledgements and references.

3. q -Volterra Covariance Equivalent Realizations

Consider the time invariant discrete bilinear system

$$\begin{aligned} x(k+1) &= Ax(k) + \sum_{i=1}^{n_u} (N_i x(k) + b_i) u_i(k) \\ y(k) &= Cx(k) \end{aligned} \quad (1)$$

where A and N_i , $i=1, \dots, n_u$ are $n_x \times n_x$ matrices, b_i , $i=1, \dots, n_u$ are $n_x \times 1$ matrices and C is an $n_y \times n_x$ matrix. The state vector $x(\cdot)$ is $n_x \times 1$, the inputs $u_i(\cdot)$, $i=1, \dots, n_u$ are scalar, zero mean, independent Gaussian white noise processes with $E u_i(j) u_i(k) = \delta_{jk}$ and for $j > k$, $E x(k) u_i(j) = 0$. The output $y(\cdot)$ is an $n_y \times 1$, zero mean, stationary stochastic process. We assume that the bilinear system driven by unit intensity Gaussian white noise is stable in the sense that the state covariance

$$X \stackrel{\Delta}{=} \lim_{k \rightarrow \infty} E x(k) x^*(k) > 0 \quad (2)$$

is finite. It can be shown that for these input processes the state covariance will satisfy the bilinear Liapunov equation

$$X = AXA^* + \sum_{i=1}^{n_u} N_i X N_i^* + BB^*, \quad B \stackrel{\Delta}{=} [b_1 \dots b_{n_u}] \quad (3)$$

We also assume that there are no redundant inputs or outputs (B has linearly independent columns and C has linearly independent rows).

Ruberti et al. [3] define the product $*$ for an $s \times 1$ vector a and an $r \times 1$ vector b and the product \square for an $m \times n$ matrix L and an $n \times s$ matrix M by

$$a * b \stackrel{\Delta}{=} \begin{bmatrix} ab_1 \\ \vdots \\ ab_r \end{bmatrix}, \quad L \square M = [L_1 \dots L_r] \square M \stackrel{\Delta}{=} [L_1 M \dots L_r M] \quad (4)$$

They also establish the following identity,

$$L[(Ma * b)] = (L \square M)(a * b) \quad (4)$$

With these definitions (1) becomes

$$\begin{aligned} x(k+1) &= Ax(k) + N[x(k) * u(k)] + Bu(k) \\ y(k) &= Cx(k) \end{aligned} \quad (5)$$

and (3) may be expressed as

$$X = AXA^* + (N \square X)N^* + BB^*, \quad N \stackrel{\Delta}{=} [N_1 \dots N_{n_u}] \quad (6)$$

The zero initial state response of the bilinear system (5) is an infinite Volterra series [4]. This series in regular form is found to be

$$\begin{aligned} y(k) &= \sum_{i_1=1}^k CA^{i_1-1} Bu(k-i_1) + \sum_{i_2=1}^k \sum_{i_1=1}^{k-i_2} CA^{i_2-1} N \square A^{i_1-1} B [u(k-i_1-i_2) * u(k-i_2)] + \\ & \sum_{i_3=1}^k \sum_{i_2=1}^{k-i_3} \sum_{i_1=1}^{k-i_2-i_3} CA^{i_3-1} N \square A^{i_2-1} N \square A^{i_1-1} B [u(k-i_1-i_2-i_3) * u(k-i_2-i_3) * u(k-i_3)] + \dots \end{aligned}$$

where identity (4) has been used repeatedly. The matrix valued function in each of the summations is called a Volterra kernel, the j^{th} Volterra kernel in regular form is then

$$h_j(i_j, i_{j-1}, \dots, i_1) \stackrel{\Delta}{=} CA^{i_j-1} N \square A^{i_{j-1}-1} \dots N \square A^{i_1-1} B \quad (7)$$

where $i_m > 1, m=1, \dots, j$ and the matrix N occurs exactly $j-1$ times. The step response, $u(k)=1_{n_u}$ for all $k>0$, is

$$y(k) = \sum_{j=1}^k \sum_{i_j=1}^k \sum_{i_{j-1}=1}^{k-i_j} \dots \sum_{i_1=1}^{k-i_2 \dots -i_j} h_j(i_j, i_{j-1}, \dots, i_1) 1_{n_u}^j$$

where 1_m is a column vector of ones with m elements. We shall call the coefficients in the step response the Volterra parameters of the bilinear system (5). The Volterra parameters of the j^{th} Volterra kernel are $n_y \times n_u^j$ matrices. We define the set of q^{th} order Volterra parameters as those coefficients in which the matrices A and N occur a total of q times. For example,

$$V_2 \stackrel{\Delta}{=} \{ CA^2 B, CAN \square B, CN \square AB, CN \square N \square B \}.$$

We now see that the step response is completely characterized by the sets of Volterra parameters. We also observe that for each k a new set of Volterra parameters effects this response. That is, if a reduced order model matches the first q sets of Volterra parameters of the full order model then it will also match the step response for $k=0, 1, \dots, q+1$.

In addition to Volterra parameters we are concerned with a covariance sequence for the bilinear system. Desai [17] and Frazho [18] utilize a covariance sequence which includes both second moments of the output and higher moments between the output and input processes in their bilinear stochastic realization theories. We also

use this type of sequence, in particular the sequence of concern is

$$\begin{aligned}
 R_0(0) &\triangleq E y(k) y^*(k) = CXC^* \\
 R_1(1) &\triangleq E y(k+1) y^*(k) = CAXC^* \\
 R_1(0,0) &\triangleq E y(k+1) [y(k) \circ u(k)]^* = CN \square XC^* \\
 R_2(2) &\triangleq E y(k+2) y^*(k) = CA^2XC^* \\
 R_2(0,1) &\triangleq E y(k+2) [y(k) \circ u(k+1)]^* = CN \square AXC^* \\
 R_2(1,0) &\triangleq E y(k+2) [y(k) \circ u(k)]^* = CAN \square XC^* \\
 R_2(0,0,0) &\triangleq E y(k+2) [y(k) \circ u(k) \circ u(k+1)]^* = CN \square N \square XC^* \\
 &\vdots \qquad \qquad \qquad \vdots \qquad \qquad \qquad \vdots
 \end{aligned}$$

where the subscript indicates the total number of occurrences of A and N, and the integers in parenthesis represent the powers of A from left to right. A typical element of the sequence is then

$$\begin{aligned}
 &R_{j-1+i_j+i_{j-1}+\dots+i_1} (i_j, i_{j-1}, \dots, i_1) \\
 &\triangleq E y(k+j-1+i_j+i_{j-1}+\dots+i_1) [y(k) \circ u(k+i_1) \circ u(k+1+i_2+i_1) \circ \dots \circ u(k+j-2+i_{j-1}+\dots+i_1)]^* \\
 &= CA^{i_j} N \square A^{i_{j-1}} N \dots N \square A^{i_1} XC^* .
 \end{aligned} \tag{8}$$

As with the Volterra parameters we shall define the set of q^{th} order covariance parameters, R_q , as those covariances in which the matrices A and N occur a total of q times, that is the set of second order covariance parameters is

$$R_2 \triangleq \{ CA^2XC^*, CN \square AXC^*, CAN \square XC^*, CN \square N \square XC^* \} .$$

These sets of covariance parameters completely characterize the stochastic bilinear system. It is worth noting that if a reduced order model matches the first q sets of covariance parameters of the full order model it will also match exactly the mean square value of the output and all output and input correlations up to q steps in time.

Consider now a reduced-order bilinear model

$$\begin{aligned}
 x_R(k+1) &= A_R x_R(k) + N_R [x_R(k) \circ u(k)] + B_R u(k) \\
 y_R(k) &= C_R x_R(k)
 \end{aligned} \tag{9}$$

where $x_R(\cdot)$ is an $n_r \times 1$ vector, $n_r < n_x$, $y_R(\cdot)$ is an $n_y \times 1$ vector, and A_R, N_R, B_R, C_R are matrices of appropriate dimensions. In addition, we assume that the state covariance X_R of the reduced model driven by zero mean Gaussian white noise is the unique positive definite solution to

$$X_R = A_R X_R A_R^* + (N_R \square X_R) N_R^* + B_R B_R^* . \tag{10}$$

We now define a particular type of reduced order model for discrete bilinear systems.

Definition: The reduced order model (9), with state covariance X_R satisfying (10) is a q-Volterra COVARIANCE Equivalent Realization (q-Volterra COVER) of the bilinear system (5) whenever

$$V_{R_i} = V_i, \quad i=0,1,\dots,q-1$$

and

$$R_{R_i} = R_i, \quad i=0,1,\dots,q-1$$

where V_{R_i} and R_{R_i} denote the sets of i^{th} order Volterra and covariance parameters of the reduced order model, respectively.

An algorithm which constructs the q-Volterra COVERS of a full order model is our main objective. One such algorithm is presented next.

4. A Model Reduction Algorithm

Suppose that a full order model (5) and a state covariance satisfying (6) are given. The q^{th} observability matrix $([3],[4],[16])$ of this model is

$$O_q \triangleq \begin{bmatrix} Q_0 \\ Q_1 \\ \vdots \\ Q_{q-1} \end{bmatrix}, \quad Q_0 \triangleq C, \quad Q_i \triangleq \begin{bmatrix} Q_{i-1}A \\ Q_{i-1}N_1 \\ \vdots \\ Q_{i-1}N_{n_u} \end{bmatrix}, \quad i=1, \dots, q-1. \quad (11)$$

The matrix partitions Q_i have dimension $(n_u+1)^{i-1} n_y \times n_x$, $i=0,1, \dots, q-1$. We observe that the matrices $Q_i B$ and $Q_i X C^*$ contain the same information as the sets V_q and R_q , respectively. Using the full order model we construct the following matrices

$$D_q \triangleq O_q X O_q^* \quad (12)$$

$$\bar{D}_q \triangleq O_q (A X A^* + (N \square X) N^*) O_q^* = O_q [A (N \square X^{1/2})] [A (N \square X^{1/2})]^* O_q^*. \quad (13)$$

As a consequence of the quadratic form and using the Liapunov equation (6) it immediately follows that the range spaces of these matrices are

$$R(D_q) = R([A X^{1/2} (N \square X^{1/2}) B]), \quad R(\bar{D}_q) = R([A X^{1/2} (N \square X^{1/2})]) \quad (14)$$

and it is obvious that $R(\bar{D}_q)$ is contained in $R(D_q)$.

We now compute a full rank factorization of D_q

$$D_q = P A P^* \quad (15)$$

where $\text{rank}(D_q) = r < n_x$. By virtue of the full rank factorization the columns of P form a basis for the range space of D_q . Introducing P^+ , the Moore-Penrose inverse of P , then it is well known that $P P^+$ is an orthogonal projector onto the range of D_q ([19]). We now partition P into blocks whose row dimensions are compatible with the partitions of O_q (11)

$$P = \begin{bmatrix} P_0 \\ P_1 \\ \vdots \\ P_{q-1} \end{bmatrix}, \quad P_i = \begin{bmatrix} P_i^A \\ N_1 \\ P_i^1 \\ \vdots \\ N_{n_u} \\ P_i^1 \end{bmatrix}, \quad i=1, \dots, q-1 \quad (16)$$

and define new matrices

$$P_A \triangleq \begin{bmatrix} P_1^A \\ \vdots \\ P_{q-1}^A \end{bmatrix}, \quad P_{N_j} \triangleq \begin{bmatrix} P_1^{N_j} \\ \vdots \\ P_{q-1}^{N_j} \end{bmatrix}, \quad j=1, \dots, n_u, \quad F \triangleq [P_A \ P_{N_1} \ \dots \ P_{N_{n_u}}], \quad \bar{P} \triangleq \begin{bmatrix} F \\ G \end{bmatrix}. \quad (17)$$

The matrix G is $(n_u+1)^{q-1} n_y \times (n_u+1)r$ and it must be determined such that

$$\bar{D} = \bar{P} \bar{\Lambda} \bar{P}^*, \quad \bar{\Lambda} = \text{diag}(\Lambda)_{n_u+1}. \quad (18)$$

where $\bar{\Lambda}$ is a block diagonal matrix with n_u+1 blocks. Given these constructions we now state our main result.

Theorem 1: Given a discrete bilinear system (A, N, B, C, X) and a matrix G in (17) such that (18) is satisfied the reduced order model $(A_R, N_R, B_R, C_R, X_R)$ of order n_r defined by

$$[A_R \ N_R] \triangleq P^+ P, \quad B_R \triangleq P^+ O_q B, \quad C_R \triangleq P_0, \quad X_R \triangleq \Lambda, \quad n_r \triangleq r \quad (19)$$

where r, P, Λ are from the full rank decomposition of D_q (15), P_0 is from the partition of P (16), and satisfies (18), is a q -Volterra COVER.

Proof: First we will show that P is the q^{th} observability matrix of the reduced order model (19). Using

decompositions (15), (18) and the range space descriptions (14) we find that \bar{P} is in the range space of P so that (19) leads to

$$P \begin{bmatrix} A_R & N_R \end{bmatrix} = \bar{P}$$

which implies that the partitions of P have the required structure (11)

$$P_0 = C_R \cdot P_1 = \begin{bmatrix} P_{1-1} A_R \\ P_{1-1} N_{R_1} \\ \vdots \\ P_{1-1} N_{R_{n_u}} \end{bmatrix}, \quad i=1, \dots, q-1.$$

To show that the reduced order model satisfies the bilinear Liapunov equation we first substitute (19) into (10) which leads to

$$A = P^+ P A P^+ P^* + P^+ O_q B B^+ O_q^* P^*.$$

Using (12), (13), (15), (18), and by pre and post multiply by P and P^* , respectively, we have

$$O_q X O_q^* = P P^+ O_q A X A^+ O_q^* P^+ P^* + P P^+ O_q (N \square X) N^+ O_q^* P^+ P^* + P P^+ O_q B B^+ O_q^* P^+ P^*.$$

Now using the projection property of $P P^+$ we find that

$$O_q (X = A X A^+ + (N \square X) N^+ + B B^+) O_q^*$$

which is known to be satisfied (6). To show that the model (19) matches Volterra parameters we again use the projection property

$$O_q B_R = P P^+ O_q B = O_q B$$

and the matching of covariance parameters follows directly from (12), (15)

$$O_q X_R O_q^* = P A P^+ = O_q X O_q^*.$$

Our remaining task is to determine the unknown matrix G in (17) in order to satisfy (18). This is the topic of the next section.

5. Parameterization of q -Volterra COVERS

To obtain a characterization of the matrix G we first examine the structure of the matrices \bar{D}_q and \bar{P} . We observe that \bar{D}_q can be partitioned as

$$\bar{D}_q = \begin{bmatrix} \bar{d}_{q-1} & \bar{d}_q \\ \bar{d}_q^* & \bar{d}_{qq} \end{bmatrix} \quad (20)$$

and that the partitioned form of the constraint (18) leads to the three relations

$$F \bar{A} F^* = \bar{d}_{q-1}, \quad F \bar{A} G^* = \bar{d}_q^*, \quad G \bar{A} G^* = \bar{d}_{qq}. \quad (21)$$

The first relation is satisfied by virtue of the construction of \bar{P} (17). It is easily seen that \bar{d}_q is contained in the range space of F so that the second relation is consistent and G^* may be expressed as ([19])

$$G^* = \bar{\Lambda}^{-1} (F^+ \bar{d}_q + (I - F^+ F) Y) \quad (22)$$

where Y is an unknown matrix with dimension $(n_u + 1) r \times (n_u + 1)^{q-1} n_y$. Substituting for G in the last relation we find that Y must satisfy the Hermitian, quadratic, matrix equation

$$Y^* K Y + L^* Y + Y^* L + M = 0 \quad (23)$$

$$K \triangleq (I - F^+ F) \bar{\Lambda}^{-1} (I - F^+ F) = K^*, \quad L \triangleq (I - F^+ F) \bar{\Lambda}^{-1} F^+ \bar{d}_q, \quad M \triangleq \bar{d}_q^* F^+ \bar{\Lambda}^{-1} F^+ \bar{d}_q - \bar{d}_{qq} = M^*. \quad (24)$$

By inspection we see that the matrix K is nonnegative definite, and that the columns of the matrix L are contained in the range space of K . Based on these observations we now state a theorem which is motivated by a result of Crone [20].

Theorem 2: Let K be an $m \times m$ nonnegative definite matrix with rank t , L an $m \times n$ matrix whose columns are contained in the range space of K and M an $n \times n$ Hermitian matrix. Then the matrix equation

$$Y^*KY + L^*Y + Y^*L + M = 0 \quad (25)$$

has a solution if and only if

$$L^*K^+L - M > 0 \quad \text{and} \quad \text{rank}(L^*K^+L - M) = s < t = \text{rank}(K). \quad (26)$$

When these conditions hold Y is a solution if and only if it has the form

$$Y = K^{+/2}(V\Sigma^{1/2}U^* - K^{+/2}L) + (I - K^{+/2}K^{1/2})\bar{Y} \quad (27)$$

where $K^{1/2}$ is the unique nonnegative definite square root of K and $K^{+/2}$ is the Moore-Penrose inverse of $K^{1/2}$. The matrix V is an $m \times s$ matrix, Σ is $s \times s$ and U is $n \times s$ and they must satisfy

$$V^*V = I, \quad R(V) \text{ is contained in } R(K), \quad U^*U = I, \quad \Sigma > 0, \quad U\Sigma U^* = L^*K^+L - M.$$

\bar{Y} is an arbitrary $m \times n$ matrix.

Proof: It is well known that if $K = W\Omega W^*$ is a full rank singular value decomposition (SVD), then

$$K^{1/2} = W\Omega^{1/2}W^*, \quad K^{+/2} = W\Omega^{+/2}W^*$$

and it follows that $K, K^{1/2}, K^{+/2}$ all have the same range space which is spanned by the columns of W , an $m \times m$ column unitary matrix. By the hypothesis that the columns of L are in the range space of K , equation (25) is satisfied if and only if

$$(K^{1/2}Y + K^{+/2}L)^*(K^{1/2}Y + K^{+/2}L) = L^*K^+L - M$$

which is consistent if and only if $L^*K^+L - M > 0$. All matrix factors of this relation are

$$K^{1/2}Y + K^{+/2}L = V\Sigma^{1/2}U^*$$

where $U\Sigma U^*$ is the full rank SVD of $L^*K^+L - M$ and V is any column unitary matrix of appropriate dimension, $m \times s$. To find a solution Y we must solve the following linear equation

$$K^{1/2}Y = V\Sigma^{1/2}U^* - K^{+/2}L. \quad (28)$$

This equation is consistent if and only if V is contained in the range space of K . Since V is column unitary the range space of V may be any m dimensional space with rank s , solutions of (28) exist if and only if $\text{rank}(L^*K^+L - M) = s < t = \text{rank}(K)$. Given that equation (28) is consistent then Y is a solution if and only if it has the following form

$$Y = K^{+/2}(V\Sigma^{1/2}U^* - K^{+/2}L) + (I - K^{+/2}K^{1/2})\bar{Y}$$

where \bar{Y} is an arbitrary $m \times n$ matrix.

The results of this theorem show that the matrix $L^*K^+L - M$ is the key to solutions of the quadratic matrix equation (23). Substituting for K, L, M from equations (24), and using the rules for the Moore-Penrose inverse of a matrix product ([21]), we find that

$$L^*K^+L - M = \bar{d}_{qq} - \bar{d}_{qF}^* \bar{\Lambda}^{-1/2} (I - (\bar{\Lambda}^{-1/2} (I - F^*F)) (\bar{\Lambda}^{-1/2} (I - F^*F))^+) \bar{\Lambda}^{-1/2} F^* \bar{d}_q. \quad (29)$$

From this equation we find an interesting result on the Moore-Penrose inverse of a quadratic form which we state without proof.

Fact: The Moore-Penrose inverse of the quadratic form $F\bar{\Lambda}F^*$ is

$$(F\bar{\Lambda}F^*)^+ = F^* \bar{\Lambda}^{-1/2} (I - (\bar{\Lambda}^{-1/2} (I - F^*F)) (\bar{\Lambda}^{-1/2} (I - F^*F))^+) \bar{\Lambda}^{-1/2} F^+ \quad (30)$$

where $\bar{\Lambda}$ is a positive definite matrix and F is any matrix which is multiplication compatible.

Using this result and equation (21) in (29) we find that

$$L^*K^+L - M = \bar{d}_{qq} - \bar{d}_{qF}^* \bar{d}_{qF}^+ \bar{d}_{q-1} \bar{d}_q \quad (31)$$

which is guaranteed to be nonnegative definite ([22]). Thus the first part of the constraint (26) of theorem will always be satisfied.

To show that the second part of the constraint (26) will also be satisfied we note that from the range space description (14),

$$r = \text{rank}(D_q) > \text{rank}(\bar{D}_q) \quad (32)$$

and from the definition of K (24), the relations (21) and the column dimension of F,

$$t \stackrel{\Delta}{=} \text{rank}(K) = \text{rank}(I - F^+F) = (n_u + 1)r - \text{rank}(\bar{D}_{q-1}) \quad (33)$$

Rohde [23] has shown that the partitioning (20) of the nonnegative definite matrix \bar{D}_q implies

$$\text{rank}(\bar{D}_q) = \text{rank}(\bar{D}_{q-1}) + \text{rank}(\bar{d}_{qq} - \bar{d}_{q,q-1}^+ \bar{d}_q) \quad (34)$$

and by using (31)

$$s \stackrel{\Delta}{=} \text{rank}(L^+K^+L - M) = \text{rank}(\bar{D}_q) - \text{rank}(\bar{D}_{q-1}) \quad (35)$$

Collecting equations (32), (33) and (34) we find that $s < t$ and therefore the second part of the constraint (26) in theorem 2 will always be satisfied.

We have shown that solutions of (23), (24) always exist and by theorem 2 they will have the form

$$Y = K^{+/2}(V\bar{E}^{1/2}U^* - K^{+/2}L) + (I - K^{+/2}K^{1/2})\bar{Y} \quad (36)$$

where $U\bar{E}U^*$ is the full rank singular value decomposition of $L^+K^+L - M$, V is any column unitary matrix whose range space is contained in the range space of K and \bar{Y} is arbitrary. We observe that the second term of (36) is in the null space of K which is also the range space of F^+ . It follows that when (36) is substituted into the expression for G^* (22) that this term will be annihilated by $(I - F^+F)$ which represents a projection onto the null space of F along the range space of F^+ . The first term of (36) is in the range space of K , or the null space of F , so that under the projection $(I - F^+F)$ it remains unchanged. Therefore G^* becomes

$$G^* = \bar{K}^{-1}(F^+\bar{d}_q + K^{+/2}(V\bar{E}^{1/2}U^* - K^{+/2}L))$$

or by using equation (24) and conjugate transposing

$$G = \bar{d}_q^+ F^+ \bar{K}^{-1} (I - (I - F^+F)((I - F^+F)\bar{K}^{-1}(I - F^+F))^+ \bar{K}^{-1}) + (\bar{d}_{qq} - \bar{d}_{q,q-1}^+ \bar{d}_q)^{1/2} UV^* ((I - F^+F)\bar{K}^{-1}(I - F^+F))^+ / 2 \bar{K}^{-1} \quad (37)$$

Equation (37) is an explicit expression for G which was the objective of this section. All of the freedom in G is contained in the column unitary matrix V whose range space is constrained to be in the null space of F .

6. Application to a Robot Manipulator

Consider the two degree of freedom manipulator illustrated in Figure 1. The arm has its center of mass at point C, and it may be translated through or rotated about the fixed point O by the force F and torque T , respectively. The manipulator carries a load at the point L.

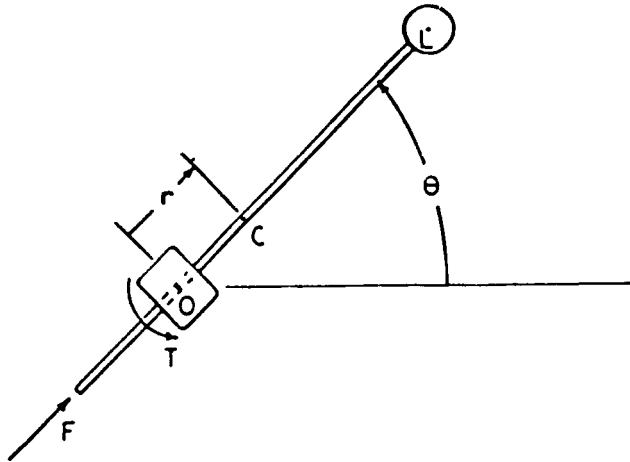

Figure 1. Two Degree of Freedom Manipulator

Treating the load as a point mass and allowing for joint stiffness and damping, the equations of motion are

$$(m + M)\ddot{r} + b_r \dot{r} + k_r r - (m + M)r\dot{\theta}^2 - M a \dot{\theta}^2 = F$$

$$(J + I + M a^2 + 2M a r + (m + M)r^2)\ddot{\theta} + b_\theta \dot{\theta} + k_\theta \theta + 2(m + M)r\dot{r}\dot{\theta} + 2M a r \ddot{\theta} = T$$

where a is the distance from C to L , M is the mass of the load, J is the moment of inertia of the joint, m is the mass of the arm and I is its moment of inertia about C . Joint stiffness and damping are represented by k_r , k_θ and b_r , b_θ , respectively. Introducing the state vector and the control

$$z = [r \dot{r} \theta \dot{\theta}]^T, u = [F T]^T$$

then the equations of motion have the generic form

$$\dot{z} = f(z) + g(z)u.$$

A bilinear model of the manipulator can be constructed by expanding each of the functions $f(\cdot)$ and $g(\cdot)$ into a power series and introducing a new state vector which contains higher order terms in z ([4]-[6]). Using the first three terms of the Taylor series expansions of $f(\cdot)$ and $g(\cdot)$ and letting

$$x = [r \dot{r} \theta \dot{\theta} r^2 \dot{r}\dot{r} \dot{\theta}\dot{\theta} r^2 \dot{r}\dot{\theta} \dot{\theta}^2 \dot{\theta}\dot{\theta}^2 r^3 \dots \dot{\theta}^3]^T$$

then we have a 34th order bilinear model and after discretization it has the form (1).

For purposes of illustration, the following numerical values are chosen: $a = 1$ m, $m = 100$ kg, $M = 50$ kg, $J = I = 100$ kg-m², and $k_r = 6$ N/m, $k_\theta = 2.5$ N/m, $b_r = 3$ N-sec/m, $b_\theta = 5$ N-sec/m. Figure 2 shows the step response of the nonlinear equations of motion and the full order bilinear model. The bilinear model provides a fair approximation to the true nonlinear system. A more accurate approximation could be made by retaining higher order terms in the power series expansions.

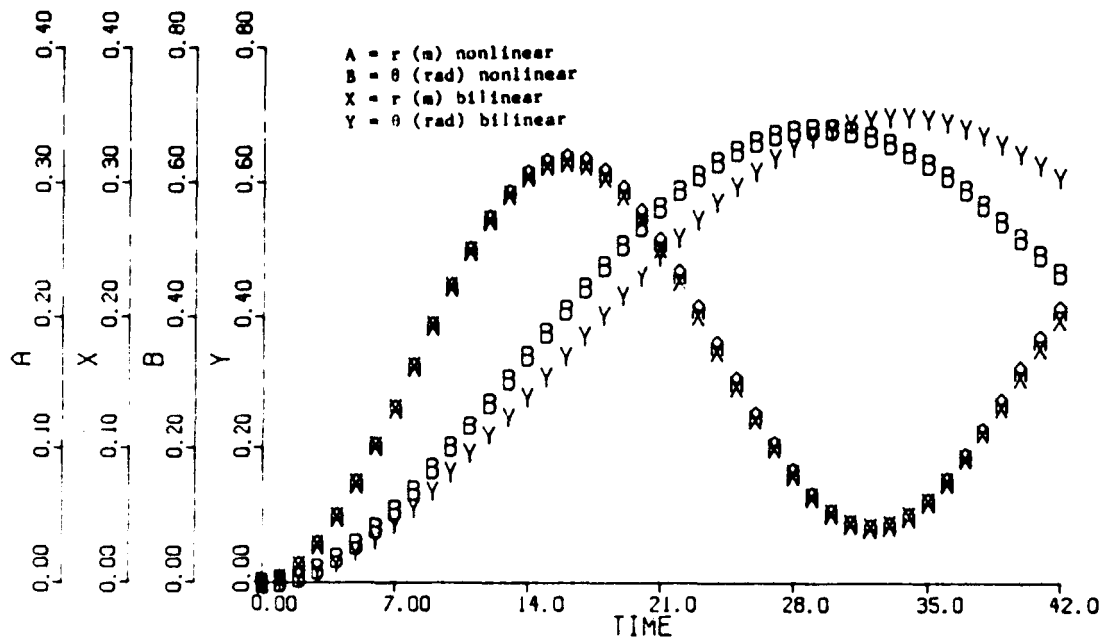

Figure 2. Step Response of Nonlinear and Full Order Bilinear Models

Applying the model reduction algorithm with $q=3$ (matching three sets of Volterra and covariance parameters) a class of 3-Volterra COVERS was obtained. These reduced models have 14 states which is a greater than fifty percent reduction in model order. Figure 3 shows the response of a reduced model from the class of 3-Volterra COVERS and the response of the full order model to a unit pulse input with a 3 second duration. Figure 4 shows the response of these models driven by a unit intensity Gaussian white noise process. In Figure 3 we see that the response of the full and reduced order bilinear models are nearly identical for the first 10 seconds. Similarly, in Figure 4 the reduced order model mimics the full order model initially. These observations are in accordance with the theory which states that the response of the reduced order model equals that of the full order system for q steps in time. However, in both cases the quality of the response of the reduced order model deteriorates with time and it eventually goes unstable. This instability is input dependent and possibly in a closed loop setting the model behavior would be acceptable for greater periods in time.

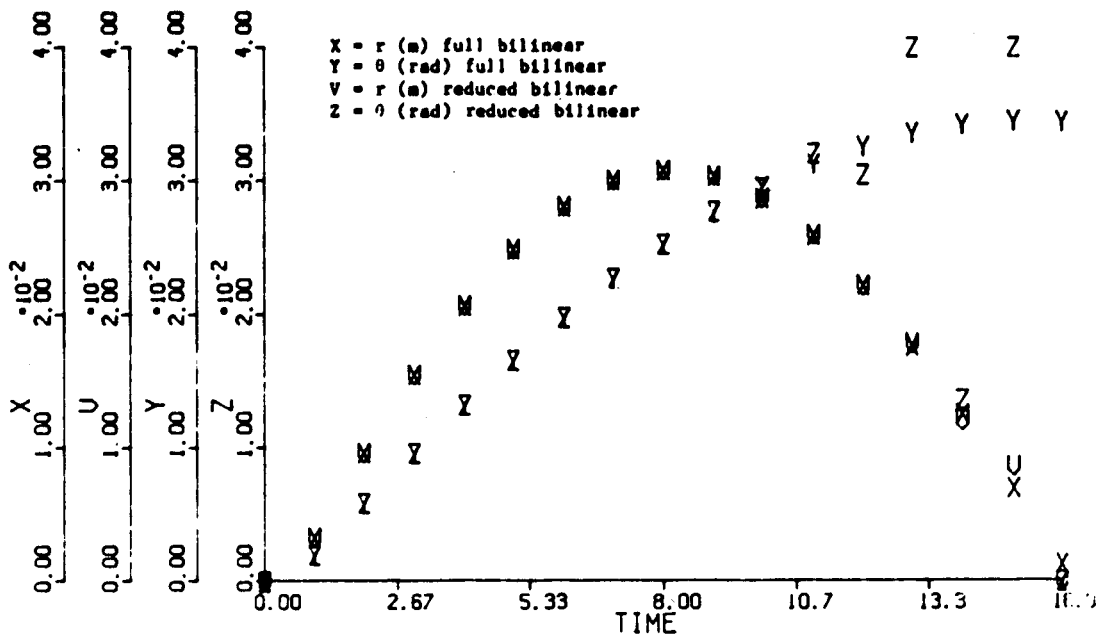

Figure 3. Deterministic Response of Full and Reduced Order Bilinear Models

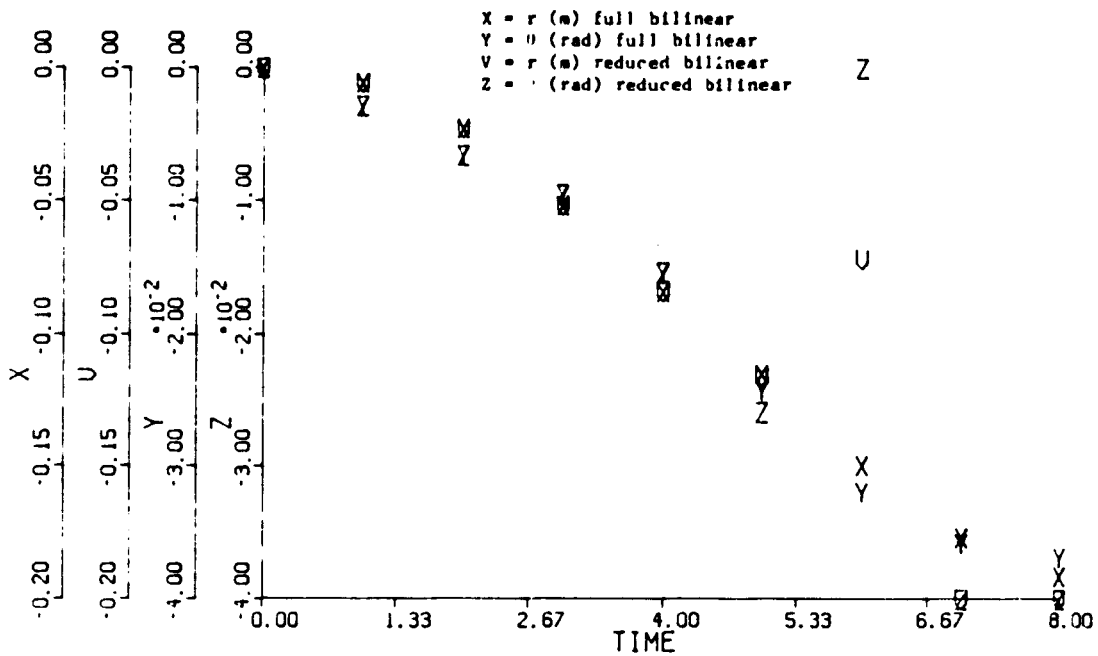

Figure 4. Stochastic Response of Full and Reduced Order Bilinear Models

7. Conclusions

A sequence of sets of Volterra parameters characterizes the deterministic bilinear system, and a sequence of sets of covariance parameters describes the stochastic bilinear system. A model reduction technique was developed for discrete bilinear systems which generates a class of reduced order models which exactly match the first q sets of Volterra and covariance parameters of the full order model. These models are therefore called q -Volterra covariance equivalent realizations, or q -Volterra COVERS. Methods to choose specific models from within the class to satisfy additional modelling considerations is a topic of future research.

8. Acknowledgements

Part of this research was sponsored by the National Science Foundation, grant MEA-8405133, and by the Hughes Aircraft Company through the Hughes Fellowship Program. We also acknowledge Uday B. Desai of Washington State University whose assistance was invaluable.

9. References

- [1] C. Bruni, G. DiPillo, and G. Koch, "Bilinear Systems: An Appealing Class of "Nearly Linear" Systems in Theory and Applications," IEEE Trans. Autom. Contr. Vol. AC-19, No. 4, Aug. 1974, pp. 334-348.
- [2] R.R. Mohler, Bilinear Control Processes, Academic Press, New York, U.S.A., 1973.
- [3] A. Ruberti, A. Isidori and P. D'Alessandro, Theory of Bilinear Dynamical Systems, Springer-Verlag, New York, U.S.A., 1972.
- [4] W. J. Rugh, Nonlinear System Theory: The Volterra/Wiener Approach, Johns Hopkins University Press, Baltimore, U.S.A., 1981.
- [5] A. J. Krener, "Linearization and Bilinearization of Control Systems," Proc. Allerton Conf. Circuits and Systems, Champagne-Urbana, U.S.A., 1974, pp. 834-843.
- [6] S. Svoronos, G. Stephanopoulos and R. Aris, "Bilinear Approximation of General Nonlinear Dynamic Systems with Linear Inputs," Int. J. Control, Vol. 31, No. 1, 1980, pp. 109-126.
- [7] B. C. Moore, "Principle Component Analysis in Linear Systems: Controllability, Observability, and Model Reduction," IEEE Trans. Auto. Control, Vol. 26, No. 1, Feb. 1981, pp. 17-32.
- [8] L. Pernebo, and L. M. Silverman, "Model Reduction via Balanced State Space Representations," IEEE Trans. Auto. Control, Vol. AC-27, No. 2, April 1982, pp. 382-287.
- [9] S. Kung and D. Lin, "Optimal Hankel-Norm Model Reductions: Multivariable Systems," IEEE Trans. Auto. Control, Vol. AC-26, No. 4, Aug. 1981, pp. 832-853.
- [10] K. Glover, "All Optimal Hankel Norm Approximations of Linear Multivariable Systems and their L_2 Error Bounds," Int. J. Control, Vol. 39, No. 6, 1984, pp. 1115-1193.
- [11] U. B. Desai, D. Pal, and R Kirkpatrick, "A Realization Approach to Stochastic Model Reduction," Int. J. Control, Vol. 42, No. 4, 1985, pp. 821-838.
- [12] B. J. Baron and A. E. Frazho, "A Hankel Matrix Approach to Stochastic Model Reduction," IEEE Trans. Auto. Control, Vol. 30, No. 11, Nov. 1985, pp. 1138-1140.
- [13] R. E. Skelton and B. D. O. Anderson, "q Markov Covariance Equivalent Realizations," Int. J. Control, Vol. 44, No. 5, 1986, pp. 1477-1490.
- [14] D. A. Wagie and R. E. Skelton, "A Projection Approach to Covariance Equivalent Realizations of Discrete Systems," IEEE Trans. Auto. Control, Vol. AC-31, No. 12, Dec. 1986, 1114-1120.
- [15] A. Youseff, D. A. Wagie and R. E. Skelton, "Linear System Approximation Via Covariance Equivalent Realizations," J. Math. Analysis and Application, Vol. 106, No.1, Feb. 1985, pp. 91-115.
- [16] C. S. Hsu, U. B. Desai and C. A. Crawley, "Realization and Approximation of Discrete Bilinear Systems," in Applied Digital Control, S. G. Tzafestas, Ed. North Holland, Amsterdam, The Netherlands, 1985, pp. 171-187.
- [17] U. B. Desai, "Realization of Bilinear Stochastic Systems," IEEE Trans. Auto. Control, Vol. AC-31, No. 2, Feb. 1986, pp. 189-192.
- [18] A. E. Frazho, "Schur Contractions and Stochastic Bilinear Systems," Proc. Conf. Inform. Sci. and Syst., Princeton, U.S.A., 1984, pp. 190-196.
- [19] A. Ben-Israel and T. N. E. Greville, Generalized Inverses: Theory and Applications, Wiley, New York, U.S.A., 1974.
- [20] L. Crone, "Second Order Adjoint Matrix Equations," Linear Algebra and its Applications, Vol. 39, 1981, pp. 61-72.
- [21] T. N. E. Greville, "Note on the Generalized Inverse of a Matrix Product," Soc. Indust. Appl. Math. Review, Vol. 8, No. 4, Oct. 1966, pp. 518-521.
- [22] A. Albert, "Conditions for Positive and Nonnegative Definiteness in Terms of Pseudoinverses," J. Soc. Indust. Appl. Math., Vol. 17, No. 2, Mar. 1969, pp. 434-440.
- [23] C. A. Rohde, "Generalized Inverses of Partitioned Matrices," J. Soc. Indust. Appl. Math., Vol. 13, No. 4, Dec. 1965, pp. 1033-1035.