

N89-27875

TDA Progress Report 42-97

January–March 1989

New Ion Trap for Atomic Frequency Standard Applications

J. D. Prestage, G. J. Dick, and L. Maleki
Communications Systems Research Section

A novel linear ion trap that permits storage of a large number of ions with reduced susceptibility to the second-order Doppler effect caused by the radio frequency (RF) confining fields has been designed and built. This new trap should store about 20 times the number of ions a conventional RF trap stores with no corresponding increase in second-order Doppler shift from the confining field. In addition, the sensitivity of this shift to trapping parameters, i.e., RF voltage, RF frequency, and trap size, is greatly reduced.

I. Introduction

There has been much recent activity directed toward the development of trapped ion frequency standards, in part because ions confined in an electromagnetic trap are subjected to very small perturbations of their atomic energy levels. The inherent immunity to environmental changes that is afforded by suitably chosen ions suspended in DC or radio frequency (RF) quadrupole traps has led to the development of frequency standards with very good stability [1], [2]. Indeed, the trapped $^{199}\text{Hg}^+$ ion clock of [1] is the most stable clock yet developed for averaging times $\geq 10^6$ seconds [3]. However, certain applications, such as millisecond pulsar timing [4] and low frequency gravity wave detection across the solar system [5], require stabilities beyond that of present day standards.

Although the basic performance of the ion frequency source depends fundamentally on the number of ions in the trap, the largest source of frequency offset stems from the motion of the atoms caused by the trapping fields via the

second-order Doppler or relativistic time dilation effect [6].¹ Moreover, instability in certain trapping parameters (e.g., trap field strength, temperature, and the actual number of trapped particles) influences the frequency shift and leads to frequency instabilities. Since this offset also depends strongly on the number of ions, a trade-off situation results, where fewer ions are trapped in order to reduce the (relatively) large frequency offset that would otherwise result.

A hybrid RF/DC linear ion trap that should allow an increase in the stored ion number with no corresponding

¹ RF and Penning traps are both subject to second-order Doppler problems related to the trapping fields. In this article, attention is confined specifically to the case of RF traps. It is simply noted that, for the same number of stored ions, magnetron rotation of the ion cloud in a Penning trap leads to a second-order Doppler shift of magnitude comparable to that for an RF trap. A Penning trap-based clock is described in [6].

increase in second-order Doppler instabilities has been designed and constructed. The 20 times larger ion storage capacity should improve clock performance substantially. Alternatively, the Doppler shift from the trapping fields may be reduced by a factor of 10 below comparably loaded hyperbolic traps.

II. Second-Order Doppler Shift for Ions in an RF Trap

Figure 1 shows a conventional RF ion trap along with the applied voltages. The trapping forces are generated by the driven motion of the ions (at frequency Ω) in the inhomogeneous electric field created by the trap electrodes [7]. Ions are trapped around the node point of the oscillating electric field at the center of the trap for certain trap voltages, ionic masses, etc. The motion in each of three directions for a single ion in an RF trap is characterized by two frequencies, the fast driving frequency Ω and a slower secular frequency ω . An exact solution to the equations of motion shows that frequencies $k\Omega \pm \omega$, $k = 2, 3, \dots$ are also present. However, in the limit $\omega/\Omega \ll 1$, the ω and $\Omega \pm \omega$ frequencies dominate, and the kinetic energy (K.E.) of a particle, averaged over one cycle of Ω , separates into the kinetic energy of the secular motion and the kinetic energy of the driven motion. The average kinetic energy is transferred from the secular to the driven motion and back while the sum remains constant, just as a harmonic oscillator transfers energy from kinetic to potential and back. The second-order Doppler shift for a small and/or hot ion cloud, where interactions between ions are negligible, is

$$\begin{aligned} \left(\frac{\Delta f}{f}\right)_{\text{hot}} &= -\frac{1}{2} \frac{\langle v^2 \rangle}{c^2} = -\frac{\langle \text{total K.E.} \rangle}{mc^2} \\ &= -\frac{\langle \text{secular K.E.} + \text{driven K.E.} \rangle}{mc^2} \\ &= -2 \frac{\langle \text{secular K.E.} \rangle}{mc^2} \\ &= -\frac{3k_B T}{mc^2} \end{aligned} \quad (1)$$

where $\langle \rangle$ indicates a time average over one cycle of Ω . An average over one cycle of ω was obtained to equate the secular and driven K.E. This is the same as a simple harmonic oscillator where the average K.E. is equal to the average potential.

Now consider the case in which many ions are contained in a trap and interactions between ions dominate. In this cold cloud model [8], [9] of the trapped ions, displacements of

individual ions from the trap center are primarily due to electrostatic repulsion between the ions, and random thermal motion associated with temperature can be assumed to be small compared to driven motion due to the trap fields. Such clouds have a constant ion density out to the edge of the plasma where the density falls off in a distance characterized by the Debye length [9]

$$\lambda_D = \sqrt{\frac{k_B T \epsilon_o}{n_o q^2}} \quad (2)$$

This cold cloud model should be useful provided the ion cloud size is large compared to the Debye length. For room temperature Hg ions held in a trap with 50 kHz secular frequency, the Debye length is about 0.2 mm.

The trap shown in Fig. 1 is described by a pseudo-potential energy [7]

$$\phi = \frac{1}{2} (m\omega_\rho^2 \rho^2 + m\omega_z^2 z^2) \quad (3)$$

where

$$\omega_\rho^2 = \frac{2q^2 V_o^2}{m^2 \Omega^2 \epsilon^4} + \frac{2qU_o}{m\epsilon^2} \quad (4)$$

and

$$\omega_z^2 = \frac{8q^2 V_o^2}{m^2 \Omega^2 \epsilon^4} - \frac{4qU_o}{m\epsilon^2} \quad (5)$$

and ϵ describes the trap size. It is assumed that the DC and RF voltages are adjusted to make the trapping forces spherical so that the ion cloud is a sphere containing N ions out to radius R_{sph} . The pseudo-potential depicts trap forces as arising from a uniform “background” charge density computed from Poisson’s equation with the above pseudo-potential:

$$n_o = \frac{3\epsilon_o m\omega^2}{q^2} \quad (6)$$

Trapped positive ions neutralize the negative background of charge, matching its density out to a radius where the supply of ions is used up.

The oscillating electric field that generates the trapping force grows linearly with distance from the trap center. The corresponding amplitude of any ion’s driven oscillation is proportional to the strength of the driving field (i.e., also increas-

ing linearly with the distance from the trap center). The average square velocity of the driven motion for an ion at position (ρ, z) is

$$\langle v^2 \rangle = \frac{1}{2} \omega^2 (\rho^2 + 4z^2) \quad (7)$$

For a given trapping strength, reflected in force constant ω^2 , the density is fixed by Eq. (6), and the radius of the spherical cloud is determined once the ion number N has been specified. The second-order Doppler shift due to the micromotion is the spatial average of $-(1/2)\langle v^2 \rangle/c^2$ over the spherical ion cloud. Using Eq. (7) for the spatial variation of the micromotion

$$\left(\frac{\Delta f}{f}\right)_{sph} = -\frac{1}{2} \frac{\overline{\langle v^2 \rangle}}{c^2} \quad (8)$$

$$= -\frac{3}{10} \frac{\omega^2 R_{sph}^2}{c^2} \quad (9)$$

$$= -\frac{3}{10} \frac{1}{c^2} \left(\frac{N\omega q^2}{4\pi\epsilon_o m}\right)^{2/3} \quad (10)$$

For typical operating conditions [8], $N = 2 \cdot 10^6$ and $\omega = (2\pi) 50$ kHz, $\Delta f/f = 2 \cdot 10^{-12}$. This corresponds to a second-order Doppler shift that is about 10 times higher than the shift for free ^{199}Hg ions at room temperature, $\Delta f/f = 3k_B T/2mc^2 = 2 \cdot 10^{-13}$.

For increased signal-to-noise in the measured atomic resonance used in frequency standard applications, it is desirable to have as many trapped ions as possible. However, as has just been seen, larger ion clouds have larger second-order Doppler shifts. This frequency offset must be stabilized to a high degree in order to prevent degradation of long-term performance. To reduce this susceptibility to second-order Doppler shift, a hybrid RF/DC ion trap has been designed and constructed that replaces the single-field node of the hyperbolic trap with a line of nodes. The RF electrode structure producing this line of nodes of the RF field is shown in Fig. 2. The ions are trapped in the radial direction by the same RF trapping forces used in a conventional RF trap, and a secular motion in that direction of frequency ω is assumed. To prevent ions from escaping along the axis of the trap, DC biased "endcap" needle electrodes are mounted on each end. Unlike conventional RF or Paul traps, this linear trap holds positive or negative ions but not both simultaneously.

Near the central axis of the trap, one assumes a quadrupolar RF electric field

$$\phi = \frac{V_o(x^2 - y^2) \cos(\Omega t)}{2R^2} \quad (11)$$

which gives the corresponding pseudo-potential energy

$$\Phi = \frac{q^2 V_o^2}{4R^4 m \Omega^2} (x^2 + y^2) \quad (12)$$

$$\equiv m \frac{\omega^2}{2} \rho^2 \quad (13)$$

Poisson's equation leads to a limiting charge density

$$n_o = \frac{2\epsilon_o m \omega^2}{q^2} \quad (14)$$

for ions held in this linear trap, where

$$\omega^2 = \frac{q^2 V_o^2}{2m^2 \Omega^2 R^4} \quad (15)$$

The motion induced by the RF trapping field is purely transverse and is given by

$$\langle v^2 \rangle = \omega^2 \rho^2 \quad (16)$$

As before, this quantity is averaged over the ion cloud to find the second-order Doppler shift

$$\left(\frac{\Delta f}{f}\right)_{lin} = -\frac{1}{2} \frac{\overline{\langle v^2 \rangle}}{c^2} = -\frac{\omega^2 R_c^2}{4c^2} \quad (17)$$

A cylindrical ion cloud of radius R_c and length L is assumed for simplicity. Equation (17) can be written in terms of total ion number, N , and trap length, L ,

$$\left(\frac{\Delta f}{f}\right)_{lin} = \left(\frac{q^2}{8\pi\epsilon_o mc^2}\right) \frac{N}{L} \quad (18)$$

In contrast to the spherical case, this expression contains no dependence on trap parameters except for the linear ion density N/L . This is also true for the relative Debye length:

$$\left(\frac{\lambda_D}{R_c}\right)^2 = \frac{1}{24} \frac{\left(\frac{\Delta f}{f}\right)_{hot}}{\left(\frac{\Delta f}{f}\right)_{lin}} \quad (19)$$

which must be small to ensure the validity of the ‘‘cold cloud’’ model. From this it is seen that the transverse dimension R of the trap may be reduced without penalty of performance, providing that operational parameters are appropriately scaled. This requires ω and Ω to vary as R^{-1} , and the applied voltage V_o to be held constant.

Assuming the traps hold the same number of ions, the second-order Doppler shift for the two traps can be compared

$$\left(\frac{\Delta f}{f}\right)_{lin} = \frac{5}{3} \frac{R_{sph}}{L} \left(\frac{\Delta f}{f}\right)_{sph} \quad (20)$$

As more ions are added to the linear trap, their average second-order Doppler shift increases. It equals that of the spherical ion cloud in the hyperbolic trap when

$$N_{lin} = \frac{3}{5} \frac{L}{R_{sph}} N_{sph} \quad (21)$$

A linear trap can thus store $(3/5)(L/R_{sph})$ times the ion number a conventional RF trap stores with no increase in average second-order Doppler shift. For the JPL-built trap, $L = 75$ mm. Taking $R_{sph} = 2.5$ mm for $2 \cdot 10^6$ $^{199}\text{Hg}^+$ ions [8], one sees that this linear trap should hold about 18 times the number of ions as that of [8].

III. Construction of a Linear Ion Trap

The linear trap built consists of four molybdenum rods equally spaced on an approximately 1-cm radius. Oxygen-free high-conductivity copper pins with DC bias are located at each end to confine ions in the axial direction and are about 75 mm apart.

The input optical system that performs state selection and also determines which hyperfine state the ions are in has been modified from the previous system [2]. The present system illuminates about 1/3 of the 75-mm long cylindrical ion cloud. An ion’s room temperature thermal motion along the axis of the trap gives an average round-trip time of 1.4 msec, a value

that is much smaller than any optical pumping, interrogation, or microwave resonance time. Thus, all the ions are illuminated, but with a lower average intensity.

In order to operate within the Lambe–Dicke regime [10], the 40.5-GHz microwave resonance radiation is propagated perpendicularly to the line of ions. The ions should then all feel phase variations of this radiation that is less than π , so that the first-order Doppler absorption in sidebands induced by an ion’s motion does not degrade the 40.5-GHz fundamental.

IV. Conclusions

Trapped ion frequency standards eliminating containing walls and their associated perturbations of the atomic transition frequencies by using electromagnetic fields alone to confine the particles. For any given trap, however, there exists a trade-off between the number of ions in the trap and a frequency shift due to second-order Doppler effects. This trade-off directly affects performance of the standard since the frequency shift is typically very much larger than the ultimate stability required and since the statistical limit to performance is directly related to ion number.

This performance trade-off was calculated for an RF trap with cylindrical geometry, a case not previously considered for a trapped ion frequency source. By replacing the single node in the RF trapping field for a spherical trap with a line of nodes, a cylindrical trap increases effective volume without increasing overall size. Furthermore, this performance is found to be independent of its transverse dimensions, as long as the driving frequency is scaled appropriately, with the driving voltage unchanged. More specifically, for the same frequency shift, a linear trap with length L can hold as many ions as a spherical trap with ion cloud diameter $6L/5$. In addition to the practical advantage of greatly reduced overall volume, a fundamental advantage is also allowed since operation within the Lambe–Dicke regime places a limit on the size of the ion cloud, a requirement that may be met for a cylindrical trap by irradiating the microwave atomic transition in a direction perpendicular to the trap’s longitudinal axis.

A trapped ion frequency source has been designed in which a cylindrical trap is implemented with a combination of RF and DC electric fields. With similar overall size and improved optical performance, this trap has 15 to 20 times the ion storage volume as conventional RF traps with no increase in second-order Doppler shift.

Acknowledgments

We wish to thank Dave Seidel for assisting in the design of the linear trap described here and G. R. Janik for helpful comments.

References

- [1] L. S. Cutler, R. P. Giffard, P. J. Wheeler, and G. M. R. Winkler, "Initial Operational Experience with a Mercury Ion Storage Frequency Standard," *Proc. 41st Ann. Symp. Freq. Control*, pp. 12-19, 1987.
- [2] J. D. Prestage, G. J. Dick, and L. Maleki, "The JPL Trapped Mercury Ion Frequency Standard," *TDA Progress Report 42-92*, vol. October-December 1987, Jet Propulsion Laboratory, Pasadena, California, pp. 13-19, February 1988.
- [3] D. W. Allan, "A Study of Long-Term Stability of Atomic Clocks," *Proc. 19th Ann. PTTI App. Plan. Meeting*, pp. 375-412, 1987.
- [4] L. A. Rawley, J. H. Taylor, M. M. Davis, and D. W. Allan, "Millisecond Pulsar PSR 1937+21: A Highly Stable Clock," *Science*, vol. 238, pp. 761-765, 1987.
- [5] J. W. Armstrong, F. B. Estabrook, and H. D. Wahlquist, "A Search for Sinusoidal Gravitational Radiation in the Period Range 30-2000 Seconds," *Astrophys. J.*, vol. 318, pp. 536-541, 1987.
- [6] J. J. Bollinger, J. D. Prestage, W. M. Itano, and D. J. Wineland, "Laser-Cooled-Atomic Frequency Standard," *Phys. Rev. Lett.*, vol. 54, pp. 1000-1003, 1985.
- [7] H. G. Dehmelt, "Radio-Frequency Spectroscopy of Stored Ions I: Storage," *Adv. At. Mol. Phys.*, vol. 3, pp. 53-72, 1967.
- [8] L. S. Cutler, R. P. Giffard, and M. D. McGuire, "Thermalization of ^{199}Hg Ion Macromotion by a Light Background Gas in an RF Quadrupole Trap," *Appl. Phys. B*, vol. 36, pp. 137-142, 1985.
- [9] S. A. Prasad and T. M. O'Neil, "Finite Length Thermal Equilibria of a Pure Electron Plasma Column," *Phys. Fluids*, vol. 22(2), pp. 278-281, 1979.
- [10] R. H. Dicke, "The Effect of Collisions upon the Doppler Width of Spectral Lines," *Phys. Rev.*, vol. 89, pp. 472-473, 1953.

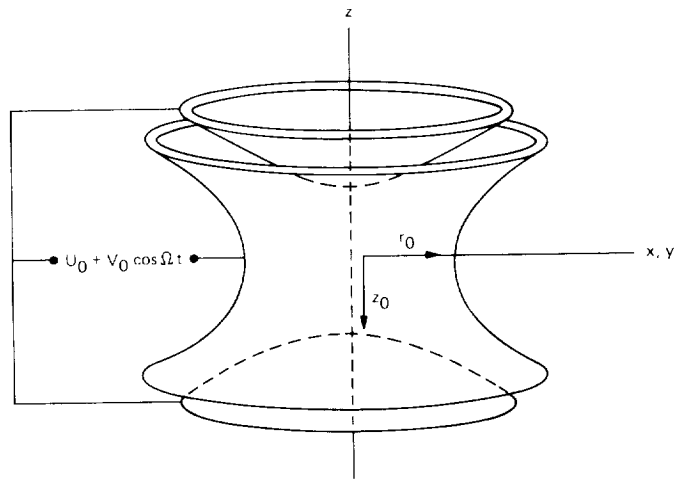

Fig. 1. A conventional hyperbolic RF ion trap. A node of the RF and DC fields is produced at the origin of the coordinate system shown.

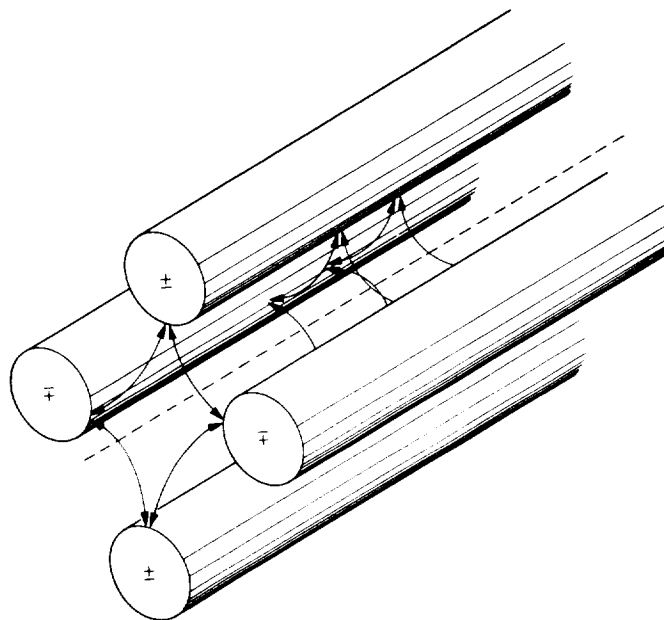

Fig. 2. The RF electrodes for a linear ion trap. Not shown are the DC endcap needle electrodes used to prevent the ions from escaping along the longitudinal axis. Ions are trapped around the line of nodes of the RF field with reduced susceptibility to second-order Doppler frequency shift.