

N 8 9 - 2 7 8 7 6

TDA Progress Report 42-97

January – March 1989

Operational Parameters for the Superconducting Cavity Maser

R. T. Wang¹ and G. J. Dick

Communications Systems Research Section

D. M. Strayer

Applied Technologies Section

Tests of the superconducting cavity maser (SCM) ultra-stable frequency source have been made for the first time using a hydrogen maser for a frequency reference. In addition to characterizing the frequency stability, the sensitivity of the output frequency to several crucial parameters was determined for various operating conditions. Based on this determination, the refrigeration and thermal control systems of the SCM were modified. Subsequent tests showed substantially improved performance, especially at the longest averaging times.

I. Introduction

The superconducting cavity maser (SCM) [1], [2], [3] is an all-cryogenic oscillator which, like other cryogenic cavity oscillators, gives stability at short measuring times that is superior to that achievable by any other means. It differs from other superconducting cavity stabilized oscillator designs [4] in its use of a very rigid ($Q \approx 10^9$) sapphire-filled stabilizing cavity and in its all-cryogenic design, excitation being provided by an ultra-low noise cryogenic ruby maser.

Performance of the SCM at short times is superior to all conventional or atomic sources, even surpassing that of the active hydrogen maser. With similar Q s, the advantage of the

SCM is its larger output power, $\approx 10^{-9}$ watt versus $\approx 10^{-12}$ watt for the hydrogen maser. Long-term performance is limited by variations in the various operating parameters, such as temperature, drive power, output voltage standing wave ratio, etc., depending on the sensitivity of the SCM to these various parameters.

Figure 1 shows a diagram of the oscillator. The three-cavity design has been previously discussed [2]. Oscillation at the signal frequency (2.69 GHz) results from application of pump power (13.15 GHz) to the ruby, which creates an inversion of the energy level populations in the ruby crystal. The frequencies of the three modes of the coupled cavity system are spaced relatively close to each other (5 percent spacing) in order to couple effectively, but are spaced far enough from each other to allow mode selection. Only one of the modes is suitable for ultra-stable operation. Tuning the regenerative frequency of

¹During the time this work was done, this author held a National Research Council–NASA/JPL Research Associateship.

the ruby (2 percent bandwidth) to that of this high-Q stabilized mode is accomplished by adjusting the current through the superconducting solenoid. The purpose of the coupling resonator is to provide physical separation of the lead-coated sapphire resonator from the magnetic field of the solenoid.

Cooling of the oscillator itself is provided by the liquid helium pot attached to the bottom cavity, and thermal regulation is achieved by varying the power dissipation in the heater as shown. Both the heat leak into the system from the waveguide at the top and the cooling power of the helium pot are subject to variation, and it is seen that, even if the changes in these heat flows are exactly cancelled by the effect of the heater, varying temperature gradients in the oscillator still result.

Figure 2 shows the stability of this oscillator when measured with a hydrogen maser as reference. Also shown are the measured stability of the H-maser and calculated short-term stability for the SCM due to additive and in-oscillator noise for the present configuration. The major features shown in Fig. 2 are:

- (1) The need for a better reference at short times in order to properly characterize the SCM
- (2) The presence of in-oscillator noise due to back-coupling from the room-temperature amplifier
- (3) The presence of substantial long-term variations in the SCM

The first of these considerations can be dealt with only by the provision of a second cryogenic oscillator, something outside the scope of this article. The second can be solved by the addition of a cryogenic isolator to prevent room-temperature radiation from coupling from the output port back into the oscillator itself. This issue is addressed by a redesign of the oscillator to allow primary coupling of the signal from an additional port in the high-Q resonator.

The long-term variations, on the other hand, could arise from any of the various parameters on which the frequency of the SCM depends. This article primarily considers the sensitivity to and variation of the operational parameters for the SCM.

II. Operational Parameters

The significant operational parameters (parameters subject to variation during operation) of the SCM are presented in Table 1. Each of these parameters is described in terms of its significance as a tuning parameter and as a likely source of variability in the output frequency. Several of the parameters are discussed in more detail in the following section.

III. Technical

In this section, the dependence of frequency on temperature and on pump power and frequency are discussed in more detail. Additionally, the discovery of sensitivity of the output frequency to a thermal gradient across the three-cavity system has given rise to a new thermal regulation system. A diagram of this system, Fig. 1(b), and improved frequency stability results, Fig. 3, are presented.

A. Temperature Dependence

Figure 4 shows a plot of the temperature dependence of the output frequency for the SCM over the temperature range between 1 and 2 kelvins. From a functional point of view, the presence of a frequency maximum at about 1.57 kelvin is an extremely desirable feature since it allows operation of the oscillator in a region of nominally zero temperature coefficient. The quadratic coefficient in $\delta f/f$ at the maximum is $3.3 \cdot 10^{-9}/\text{kelvin}^2$. This means that a temperature accuracy of one millikelvin together with a stability of 30 microkelvins allows a frequency stability of

$$\frac{\delta f}{f} = 2 \cdot 10^{-16}$$

An additional advantage of this mode of operation is the ease of refrigeration at a temperature of 1.57 K in comparison to the initial design temperature of 0.9 K. New options for refrigeration are also available. For example, operation at 1.57 K allows the use of a continuous-flow helium cryostat rather than the batch-mode system required at the lower temperature.

The negative temperature coefficient exhibited by the data in Fig. 4 is easy to understand at the higher temperatures, and was anticipated in the design of the SCM. It is due to a combination of thermal expansion and superconducting penetration depth effects, both of which show a negative slope. However, both of these effects were expected to “freeze out” at the lowest temperatures—hence the (previous) 0.9 kelvin operating temperature. The contribution with positive slope at the lower temperatures had been observed previously, but its nature and cause had not been identified. Also, its consequence, the maximum with temperature, had not been discovered.

Measurements of the effect on the operating frequency of a temperature gradient across the oscillator now point to the ruby resonator as a likely candidate for the positive slope. The sign of the thermal gradient effect is consistent with this identification. In addition, the magnitude agrees with the measured slopes of low- and high-temperature parts combined with a rough estimate of the thermal conductivity of the coupling resonator. A positive temperature coefficient would result

from the demagnetization field due to the changing alignment of chromium spins in the ruby. Although the ruby resonator seems a likely candidate, the effect has not been positively identified.

B. Pump Power and Frequency

Figure 5 shows a plot based on measurements of the SCM output frequency dependence on pump power and frequency. Pump amplitude is shown in terms of the attenuation inserted in the pump waveguide. Due to vagaries of the plotting routine, attenuation was divided by a factor of 1000 before plotting. The discrete nature of the data is discernible in the ripples at the bottom of the valley in the center of the figure, for example.

Since the pump power is very much more difficult to stabilize than its frequency, the major feature of the plot shown is the valley down the middle where the sensitivity to pump power is greatly reduced. In this region the slope is typically $\leq 2 \cdot 10^{-13}/\text{dB}$, a value 100 times smaller than on the outside slopes. A second feature is the saturation at higher power, where the frequency changes less rapidly. These features are somewhat variable, with an extremum at low power also sometimes observed. A pronounced limiting effect, in which the oscillation amplitude shows a somewhat soft "clipping" effect, is also associated with pump frequencies showing the rapid variation of frequency with amplitude. Because of the variability between subsequent reworks of the oscillator assembly, it seems likely that this interaction is not fundamental to either the ruby maser or to the high-Q resonator but may be due to an interaction between pump and oscillation frequencies at a demountable joint in the coupling resonator.

C. Modification and Test

Figure 1(b) is a diagram showing the modified refrigeration and thermal regulation system. Where the old helium tank was located below the oscillator and attached at its lower extremity, the continuous flow cooler is now mounted above the oscillator in order to intercept the varying heat flow from above.

Compensation for these variations is now accomplished by means of a heater placed *above* the refrigerator, so that no thermal gradients are generated below the heater itself. Variations in cooling power in the refrigerator are also compensated for by this heater with no resultant gradients below the refrigerator. Except for incidental electrical leads associated with the thermometry, the only thermal contact to the oscillator takes place at one point, the top, and so thermal gradients are effectively eliminated.

Stability results obtained with the modified oscillator are shown in Fig. 5. Again, little information can be discerned regarding the short-term stability, except that it is better than that of the best available reference, the hydrogen maser. Long-term stability, however, has been significantly improved by the modifications, with results in the mid- 10^{-15} range obtained for times longer than 30 seconds.

IV. Conclusions

A detailed study of the operating parameters of the superconducting cavity maser disclosed regions of operation for the various parameters that are substantially more advantageous than those previously found. On the basis of this study, the cryogenics of the oscillator were modified to optimize operation at a new operating temperature and to eliminate thermal gradients. Stability results for the modified SCM show substantially improved long-term stability compared to previous results. Results for shorter measuring times continue to be better than can be measured using the best reference presently available.

With the addition of the continuous flow refrigerator, it may now be possible to incorporate a closed-cycle refrigerator and so eliminate all need of disposable cryogenics. Commercial coolers are available that could provide the needed 20-milliwatt helium flow presently used. Such a cooler would reduce the overall size by eliminating the need for a large helium reservoir. Possible performance degradation due to mechanical motion in the cooler would need to be examined experimentally.

Acknowledgments

Special thanks to Bill Diener for his assistance in ultrastable measurements, Roland Taylor for easy access to the capabilities of the Test Facility, Chuck Greenhall for software enhancements meeting our special requirements, and Tom Tucker for assistance and support with hydrogen maser measurements.

References

- [1] S. Thakoor, D. M. Strayer, G. J. Dick, and J. E. Mercereau, "A Lead-on-Sapphire Superconducting Cavity of Superior Quality," *J. Appl. Phys.*, vol. 59, pp. 854–858, 1986.
- [2] G. J. Dick and D. M. Strayer, "Development of the Superconducting Cavity Maser as a Stable Frequency Source," *Proceedings of the 38th Annual Frequency Control Symposium*, pp. 435–446, 1984.
- [3] D. M. Strayer and G. J. Dick, "The Superconducting Cavity Maser Oscillator—Toward Higher Stability," *Proceedings of the 18th Annual Precise Time and Time Interval (PTTI) Planning and Applications Meeting*, pp. 601–609, 1986.
- [4] S. R. Stein and J. P. Turneaure, "The Development of the Superconducting Cavity Stabilized Oscillator," *Proceedings of the 27th Annual Frequency Control Symposium*, pp. 414–420, 1975.

Table 1. Description of the significant operational parameters of the SCM

Parameter	Tuning Functionality	Significant Variability
Temperature	Operating range from below 0.8 K to above 2.0 K for normal SCM operation. Variation can change the sign of sensitivity of operational frequency to temperature. Proper choice allows operation with near-zero temperature coefficient.	Substantial instability. Medium- and long-term variability of 10^{-4} to 10^{-5} K. Sensitivity coefficient 0 to $\pm 10^{-9}/\text{K}$.
Thermal Gradient	No functional significance.	Marked problems due to variation in regulating heater power. Best expressed in terms of sensitivity to heat flow. Value is $\approx 10^{-9}/\text{watt}$. Value of heater power is typically 10^{-3} to 10^{-2} watt. Variability of heater power is 10 percent to 50 percent.
Magnetic Bias	Variable by 2 percent about optimum value of ≈ 500 gauss. No important effect on frequency sensitivity coefficients.	No problems observed. Sensitivity is $\approx 10^{-9}/\text{gauss}$. Use of a persistent-mode superconducting magnet at this relatively low field allows very high stability.
Pump Power	Oscillation requires 10^{-4} watts or more to be coupled to low temperature region. Depending on pump VSWR matching, may have 5 to 20 dB of range available for oscillation using 100 mW klystron source. Significant influence on sensitivity to pump power and frequency.	Substantial instability. Variability of amplitude of typical microwave sources is 10^{-2} to 10^{-4} dB. Essentially impossible to regulate power actually applied to ruby due to variations in thermal profile of feed waveguide. Sensitivity is 0 to $10^{-11}/\text{dB}$.
Pump Frequency	≈ 20 MHz variation allowed about optimum frequency of 13.15 GHz. Important influence on sensitivity of operational frequency to pump power.	No problems in principle due to ability to "bootstrap" pump stability from SCM stability. No significant problems in practice with quartz crystal-stabilized klystron source.
Signal Coupling	Influences fractional output power and signal VSWR sensitivity. Also (incidentally) an important tool for adjustment of pump VSWR.	Possible source of drift due to varying temperature profile with helium level. Magnitude not known.
Signal VSWR	No significant function.	Substantial burden placed on stability of room temperature signal connections. Maximum variability is $\approx 10^{-10}$. The fix for this is addition of a low-temperature isolator.

(a) ORIGINAL SCM OSCILLATOR

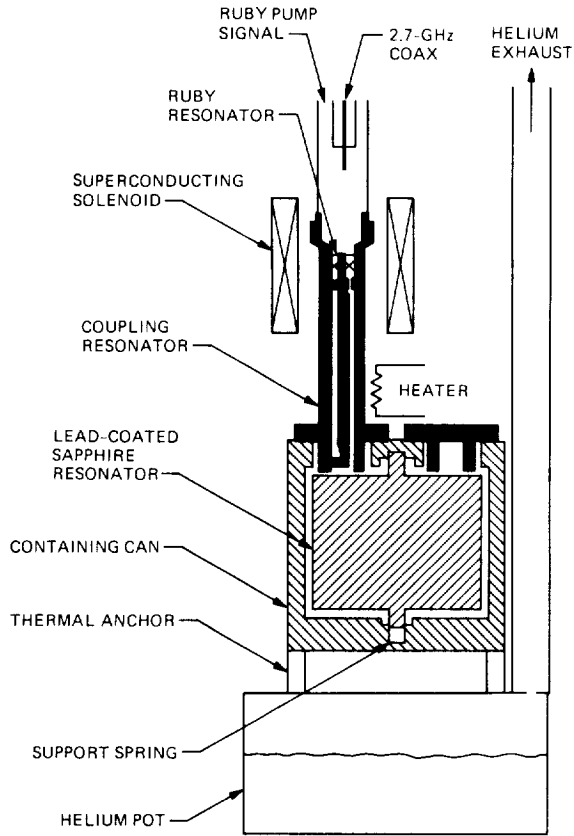

NOT SHOWN:
2-STAGE ELECTRONIC TEMPERATURE REGULATION
ELEMENTS AND FILL LINE TO HELIUM POT

(b) MODIFIED SCM OSCILLATOR

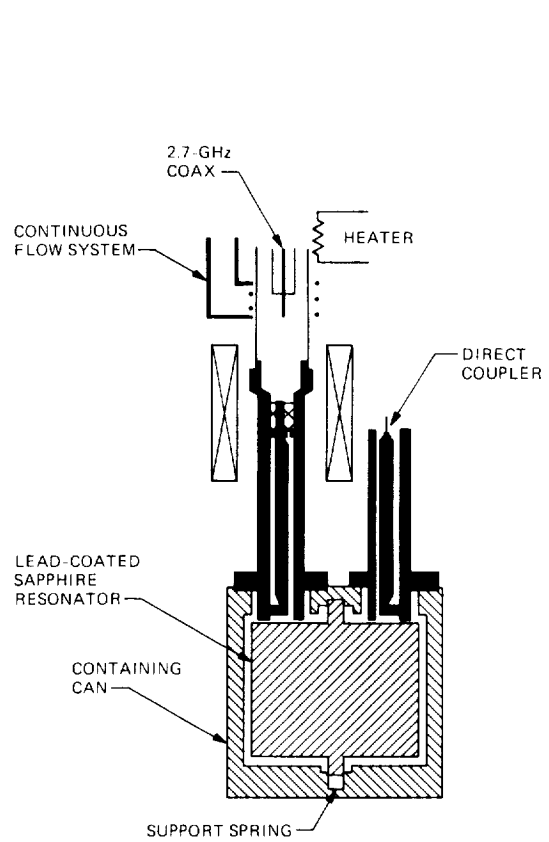

Fig. 1. Schematic diagrams of the SCM oscillator: (a) original configuration and (b) modified oscillator. Modifications prevent regulating heat flow from flowing through the oscillator itself. Direct coupler was not implemented for any data presented in this article.

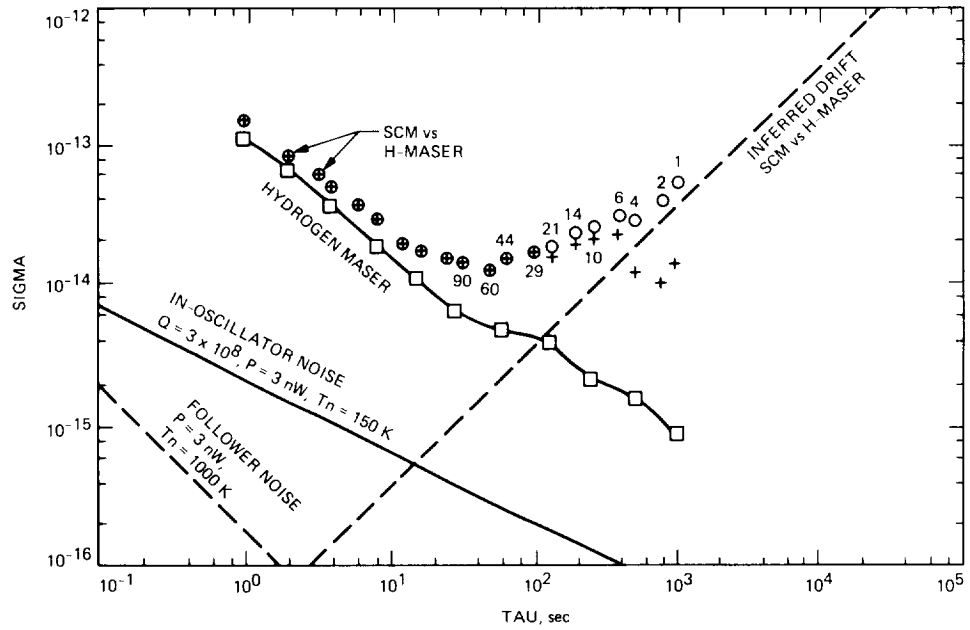

Fig. 2. Allan variance of stability of superconducting cavity maser in first tests with hydrogen maser reference oscillator. Points marked + show data with drift removed; data (circles) are accompanied by number of samples. Also shown are measured hydrogen maser stability and the calculated effect of in-oscillator and added noise based on measured operating conditions and an assumed in-oscillator noise temperature of 150 kelvins.

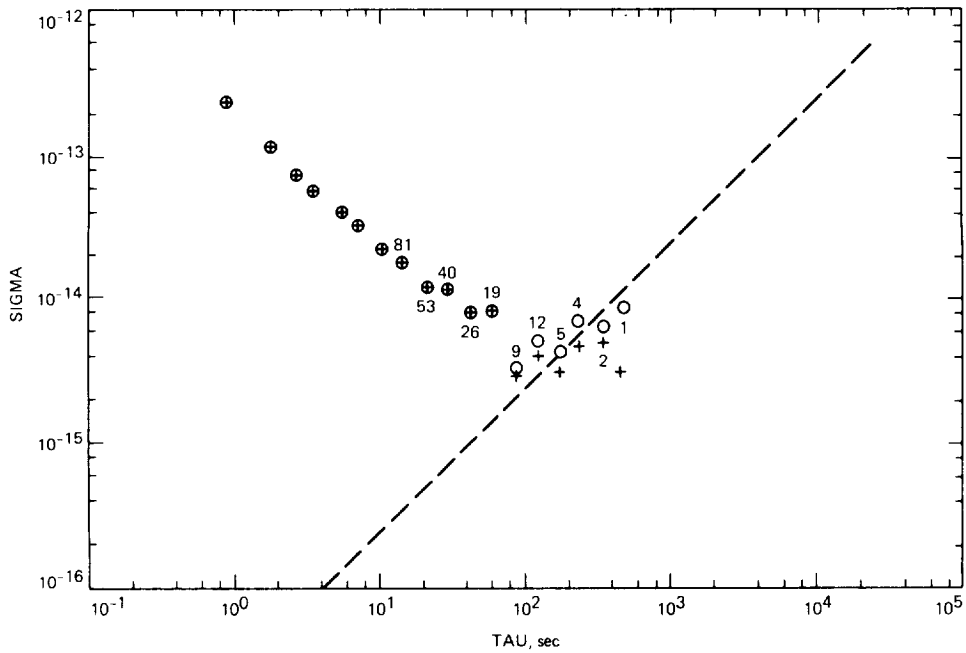

Fig. 3. Plot of Allan variance of SCM stability after modifications, H-maser reference.

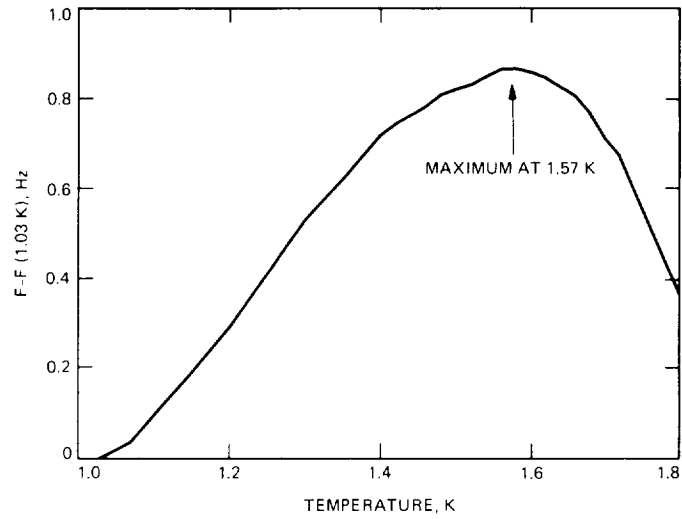

Fig. 4. Measured frequency versus temperature plot for range 1–1.8 kelvin. The 0.9-Hz frequency variation is referred to ≈ 2.69 GHz reference.

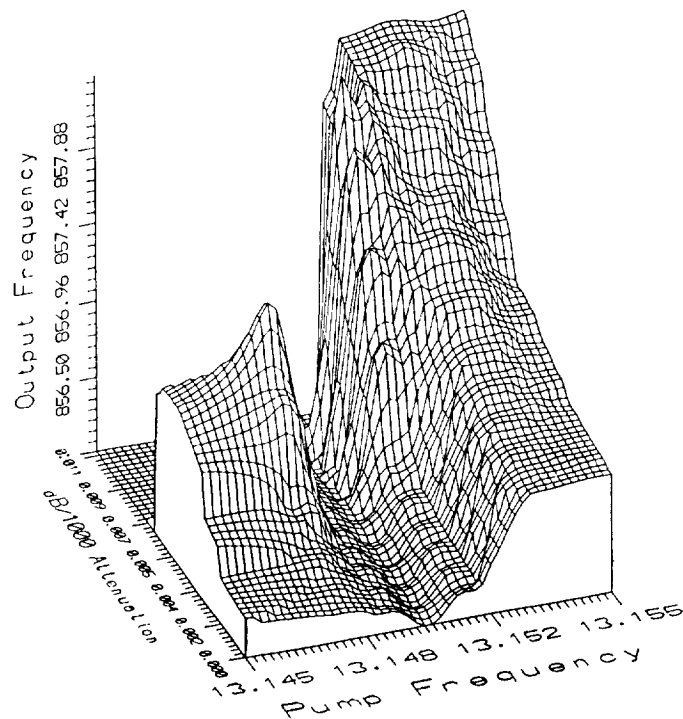

Fig. 5. Three-dimensional plot showing dependence of output frequency on pump signal frequency and power. Output frequency is referred to ≈ 2.69 GHz reference. Pump power is indicated by attenuation value. Due to vagaries of the plotting routine, the 0–11-dB attenuation range is plotted as dB/1000. Pump frequency is measured in GHz.