

N 8 9 - 2 7 8 7 9

TDA Progress Report 42-97

January - March 1989

Stabilized Fiber-Optic Frequency Distribution System

L. E. Primas, G. F. Lutes, and R. L. Sydnor
Communications Systems Research Section

A technique for stabilizing reference frequencies transmitted over fiber-optic cable in a frequency distribution system is discussed. The distribution system utilizes fiber-optic cable as the transmission medium to distribute precise reference signals from a frequency standard to remote users. The stability goal of the distribution system is to transmit a 100-MHz signal over a 22-km fiber-optic cable and maintain a stability of 1 part in 10^{17} for 1000-second averaging times. Active stabilization of the link is required to reduce phase variations produced by environmental effects, and is achieved by transmitting the reference signal from the frequency standard to the remote unit and then reflecting back to the reference unit over the same optical fiber. By comparing the phase of the transmitted and reflected signals at the reference unit, phase variations of the remote signal can be measured. An error voltage derived from the phase difference between the two signals is used to add correction phase.

I. Introduction

With the current advances in the development of precise frequency standards, greater emphasis is being placed on frequency distribution systems that can distribute the reference signal derived from a standard without appreciably degrading it. Often the reference signal must be distributed tens of kilometers. The high cost of developing and maintaining a state-of-the-art frequency standard makes it beneficial to have one precise standard at a complex and to distribute the reference signal from this standard to various users within the complex. Furthermore, future scientific experiments may also gain from having coherent signals at several remote locations.

The Deep Space Network, supported by NASA/JPL [1], is a prime contender for such a distribution system. Projects supported by the DSN that require this type of distribution system include unmanned space flight projects, flight radio

science, radio and radar astronomy, very-long-baseline interferometry, geodynamic measurements, and the search for gravitational waves.

The frequency distribution system at Goldstone, California must distribute reference frequencies generated by a hydrogen maser over distances as great as 30 km. The 100-MHz signal generated by the maser typically has an Allan deviation of 1 part in 10^{15} for 1000-second averaging times. To ensure minimal degradation of the reference signal, the distribution system should be at least 10 times more stable than the frequency standard. With expected future improvements in frequency standards, even greater stability of the distribution system will be necessary.

There are two basic limitations in frequency distribution systems. The first is a distance limitation set by the signal-

to-noise-ratio (SNR) of the received signal. The SNR is limited by the amount of available input power from the frequency source and the loss in the distribution system. The second limitation is the degradation of the frequency stability due to variations in the group delay of the signal as it is transmitted through the medium. Variations in group delay are caused by physical changes in the transmission medium. A constant rate of change in group delay does not affect the frequency stability, but a change in the rate of group delay does degrade the frequency stability. This is shown in the following equation

$$\frac{d(\Delta f)}{dt} = f \frac{d^2 D}{dt^2}$$

where D is the group delay, Δf is the frequency offset, and f is the transmitted frequency. Variations in group delay are due primarily to temperature changes in the transmission medium. Thus they can be reduced by decreasing the temperature change, increasing the time constant of the medium, choosing a medium with a small thermal coefficient of delay (TCD), or using optical and electronic feedback.

II. Previous versus Current Frequency Distribution Systems

As previously stated, frequency distribution systems have been primarily limited by the distance allowable for distribution and the effects of changing group delay. Coaxial distribution systems are especially subject to these limitations. The loss in 2.22-cm (7/8-inch) diameter coaxial cable at 100 MHz is 6.4 dB/km (0.5 dB/100 ft) and the TCD is greater than 15 ppm/°C at 25 °C. The transmission length required to transmit a certain input power through a transmission medium and maintain a certain SNR is given by

$$L = \frac{P_{in} - SNR + 204}{32.81\alpha}$$

where

L = length of kilometers

P_{in} = input power in dBW

SNR = signal-to-noise ratio in dB

α = cable attenuation in dB/100 ft

Thus, with 1 kilowatt of input signal power, a 100-MHz reference signal can only be distributed 7 km and maintain a SNR of 120 dB, the level required by the fiber-optic link. This assumes a thermal noise power in a matched load resistance at 300 K of -204 dBW/Hz.

Microwave distribution systems have also been used in the Goldstone complex. Microwave distribution systems have shortcomings in that they are highly susceptible to interference and require large input powers and repeaters to go several kilometers. Because of the limited bandwidth of microwave systems, the 100-MHz signal cannot be transmitted directly over microwave links.

Fiber-optic cable is the best distribution medium for transmitting precise reference frequencies. The loss in typical fiber-optic cable is less than 0.5 dB/km at optical wavelength 1300 nm. A typical laser transmitter puts out 0 dBm and is attenuated less than 11 dB over 22 km. Standard single-mode fiber-optic cable has a TCD of 7 ppm/°C [2] making it less susceptible to temperature changes than coaxial cable. The fiber-optic cable used at the Goldstone complex is buried 1.5 m underground, making the fiber quite insensitive to diurnal temperature changes. Fiber-optic cable has additional advantages in that the fiber is insensitive to electromagnetic interference (EMI) and radio frequency interference (RFI) and can be made less sensitive to microphonics using an optical isolator between the laser transmitter and the fiber-optic cable [3]. Another advantage of using fiber-optic cable as the transmission medium is that the superior performance of the optical components make it quite practical to transmit the signal simultaneously in both directions in the same fiber. This proves to be a key factor in actively stabilizing the distribution system.

III. Active Stabilization of a Fiber-Optic Frequency Distribution System

Passive stabilization of fiber-optic transmission links, such as burial of the cable, limits achievable stabilities to one part in 10^{15} [4].

The frequency distribution system consists of a reference unit containing the frequency standard, and a remote unit, where the reference frequency is to be transmitted. The method for actively controlling the phase variations in the fiber is based on maintaining a constant phase relation between the input phase and the phase of the received signal.

A signal passing through the fiber-optic cable in both directions experiences identical delay in each of the two directions. The midpoint of the signal is at the far end of the cable and experiences exactly half of the round-trip delay. If the phases of the transmitted and received signals at the reference end of the cable are conjugate, the phase at the remote end is independent of phase delays in the medium (Fig. 1). An electronic device that detects the phases of the transmitted and received signals at the input to the fiber and adds enough phase to

maintain conjugation is called a phase conjugator (Fig. 2). The phase conjugator is the key element of the actively controlled fiber-optic distribution system.

The reference unit consists of the frequency standard, the phase conjugator, a fiber-optic transmitter, a fiber-optic receiver, an optical coupler, and a phase-lock loop (PLL) (Fig. 3). The remote unit consists of a 50/50 mirror, a fiber-optic receiver, and a PLL.

The phase conjugator compares the phase of the transmitted and received signals in the reference unit and an error voltage derived from the phased difference is used to control a voltage-controlled oscillator (VCO) (Fig. 4). The design of this phase conjugator requires a 100-MHz reference signal and a 20-MHz auxiliary signal. A previous design used a single 100-MHz reference signal, but required two precisely matched phase detectors and tightly controlled signal levels. By using the 20-MHz auxiliary signal, a single phase detector can be used to measure phase error.

The 100-MHz signal and the 20-MHz signals are multiplied together in mixer M1 to produce 80-MHz and 120-MHz signals [5]. A power splitter S1 separates the signal out of mixer M1 into two signal paths. Band-pass filters (BPFs) in each signal path separate the 80-MHz and 120-MHz signals. The 80-MHz signal and the 100-MHz signal from the VCO are multiplied in mixer M2 to produce a 20-MHz intermediate frequency (IF) signal. The 20-MHz IF signal contains the instantaneous phase difference between the VCO signal and the 80-MHz signal.

The 120-MHz signal and the 100-MHz signal reflected from the remote unit are multiplied together in mixer M3 to produce another IF signal. This 20-MHz IF signal contains the instantaneous phase difference between the reflected signal (100 MHz) and the 120-MHz signal.

The phase detector (PD) receives the two 20-MHz IF signals and produces an error voltage that is proportional to the phase difference between them. The error voltage is applied to the VCO control input through the inner loop filter (ILF). Delay changes in the fiber-optic cable result in changes in the control voltage; this voltage controls the phase of the VCO relative to the 100-MHz reference signal.

The output of the VCO is divided into two signals in the RF power splitter S2. One of the signals is received by mixer M2 and the other modulates the optical carrier emitted from the laser transmitter.

The modulated optical signal is transmitted to the remote unit through the optical coupler. The 50/50 mirror at the

remote unit reflects half of the optical signal back toward the reference unit while the other half passes through the mirror to the optical receiver. The receiver demodulates the optical signal and amplifies the resulting 100-MHz RF signal. A PLL filters the signal to be used at the remote unit [6]. The reflected optical signal returns to the reference unit where it passes through the optical coupler and is detected by another optical receiver. This signal is also filtered by another PLL and provides a constant amplitude signal into mixer M3. With the signal back at the reference unit, the system loop is closed.

IV. Stabilizer Test Setup

The latest [7] version of the stabilizer has each element packaged in an aluminum RFI-shielded box with 60 dB of power supply filtering. A new laser is used that is less sensitive to reflections back into the laser. The 80-MHz and 120-MHz band-pass filters were also improved.

The stabilizer does require initialization using a manual phase shifter (Fig. 4). The phase shifter is used to compensate for the delays in the fiber-optic transmitter and fiber-optic receiver, to ensure that the phases of the transmitted and received signals are conjugate at the input to the fiber.

The stabilizer was tested with a 4-km link of fiber which was placed on a fiber-optic test rack (Fig. 5). The test rack allows better air circulation and thus a shorter time constant for the tests. The entire rack was placed in a test chamber where the humidity, temperature, and pressure could be varied. The temperature in the chamber was varied in temperature steps of various sizes and over various time intervals. The phase at the reference unit (near-end) receiver and transmitter and the phase at the remote unit (far-end) receiver were compared to the 100-MHz reference signal (Fig. 6).

V. Results

Several tests were performed with the stabilizer. By measuring the response of the stabilizer to a step change and a linear variation in temperature, the correction factor of the stabilizer was determined. For a step change in temperature from 15 °C to 35 °C, the phase at the reference unit transmitter and receiver changed by 90 degrees and the phase at the remote unit changed by about 2 degrees; thus the stabilizer provided a 45 times improvement (Figs. 7(a)-7(d)). The glitch in the curve is probably due to optical leakage of the 100-MHz reference signal through the coupler directly into the reference unit receiver, causing a cross modulation of the leakage signal and the reflected signal. If the results of this experiment are considered over the first hour, the reference phases changed by 25 degrees while the remote phase changed by 0.5 degree,

for a 50 times improvement (Figs. 8(a)–8(d)). Results from the test with a linear change in temperature show 20 degrees of phase change at the reference unit and 0.1 degree of phase change at the remote unit, resulting in a 200 times improvement (Figs. 9(a)–9(d)). The ripple effect in the remote unit’s phase is probably due to reflections from the end of the fiber into the fiber-optic transmitter. With more optical isolation this effect should be reduced.

VI. Future Improvements

The results of initial tests on the stabilizer are encouraging. The factor of 10 times reduction in phase variations with the stabilizer seems to be readily attainable, with potential for even greater improvements. New tests with a sinusoidal variation in temperature over diurnal time periods need to be performed to simulate more realistic time and temperature variations. Current tests have put the stabilizer through conditions too severe to realistically simulate field conditions, but the tests provide a basis from which realistic measurements will result.

The first step in improving the stabilizer is to reduce the losses in the system. Once losses are reduced, the return signal will be much larger than the leakage signal through the coupler. The phase variation caused by the difference between the return signal and the leakage signal is

$$\Phi = \arctan [10^{-R/20}]$$

where Φ is the phase variation in degrees and R is the difference between the return signal and the leakage signal in dB. Specifically, if the return signal is 40 dB greater than the leakage signal, the resulting phase variations will be 0.57 degree. By reducing the losses and making the return signal 60 dB greater than the leakage signal, the resulting phase variation will be 0.057 degree.

After the losses have been reduced, any further problems with leakage may be eliminated by using techniques such as transmitter/receiver switching. Switching the transmitter and receiver eliminates the interference problem of the leakage signal.

VII. Conclusion

A method of active stabilization of frequencies distributed over fiber-optic cable has been demonstrated and proves to be more than adequate for current frequency standards and distribution lengths. Current frequency standards require a 10 times reduction in phase variations, and the described stabilizer provides at least a 40 times reduction over a 4-km link. Theoretical calculations predict phase reduction factors of 500 will be attainable by reducing optical losses and leakage.

Acknowledgments

The authors wish to thank Phuong Tu, Bill Diener, and Al Kirk for their help in making the measurements.

References

- [1] *The Deep Space Network*, JPL 400-333, Jet Propulsion Laboratory, Pasadena, California, January 1988.
- [2] G. Lutes, "Experimental Optical Fiber Communications Link," *TDA Progress Report 42-59*, vol. July-August 1980, Jet Propulsion Laboratory, Pasadena, California, pp. 77-85, October 15, 1980.
- [3] G. Lutes, "Optical Fibers for the Distribution of Frequency and Timing References," *Proceedings of the 12th Annual Precise Time and Time Interval (PTTI) Applications and Planning Meeting*, NASA Conference Publication 2175, Goddard Space Flight Center, Greenbelt, Maryland, pp. 663-680, December 1980.
- [4] G. Lutes, "Reference Frequency Distribution Over Optical Fibers: A Progress Report," *Proceedings of the 41st Annual Frequency Control Symposium*, pp. 161-166, May 27-29, 1987.
- [5] A. P. Sage, *Linear Systems Control*, Chesterland, Ohio: Matrix Publishers, Inc., 1987.
- [6] F. M. Gardner, *Phaselock Techniques*, New York: John Wiley and Sons, Inc., 1966.
- [7] L. Primas, G. Lutes, and R. Sydnor, "Fiber Optic Frequency Transfer Link," *Proceedings of the 42nd Annual Symposium On Frequency Control*, pp. 478-484, June 1-3, 1988.

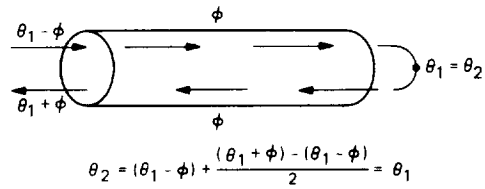

Fig. 1. Phase conjugation at input to optical fiber.

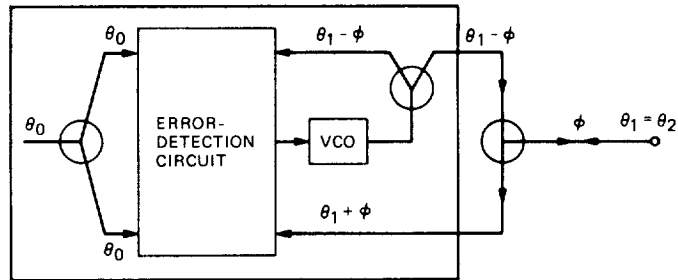

Fig. 2. Phase conjugator.

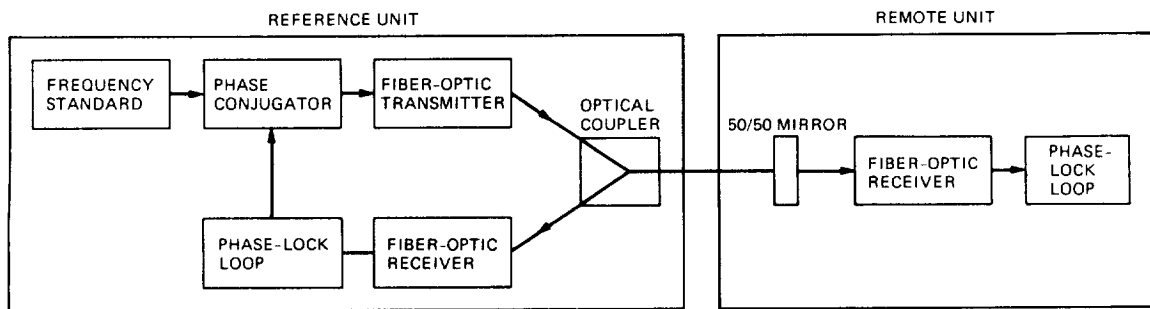

Fig. 3. Fiber-optic frequency distribution system.

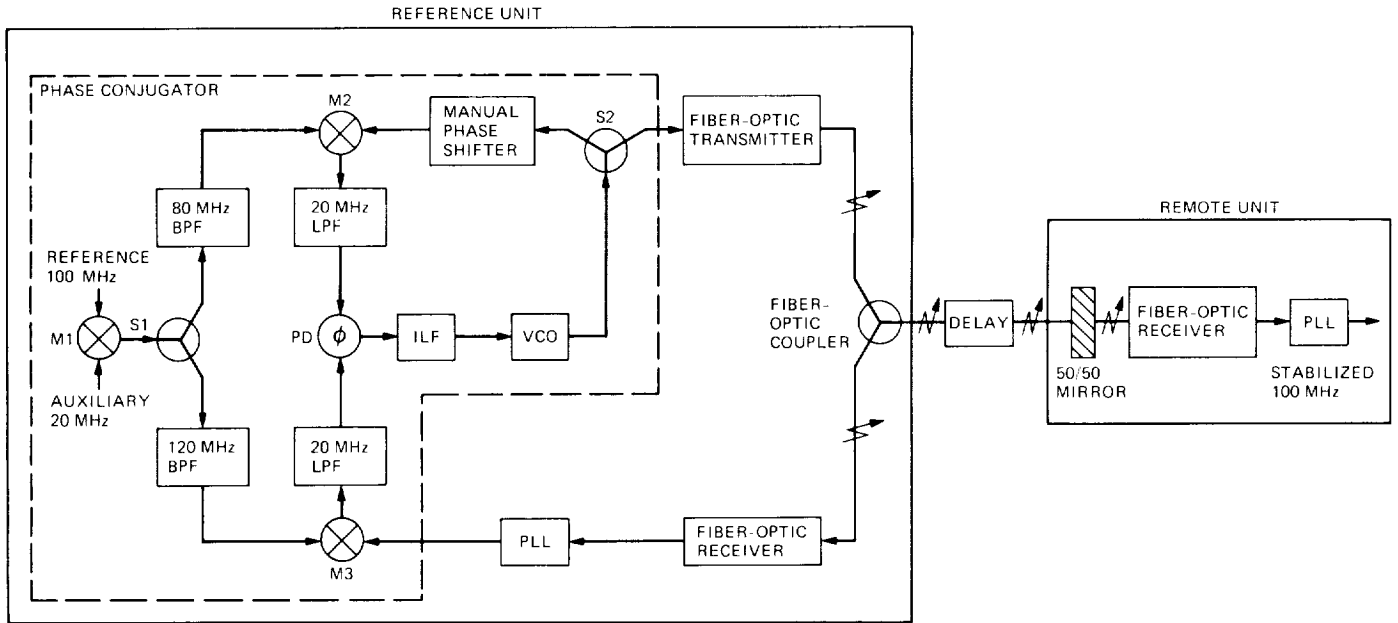

Fig. 4. Block diagram of fiber-optic stabilizer.

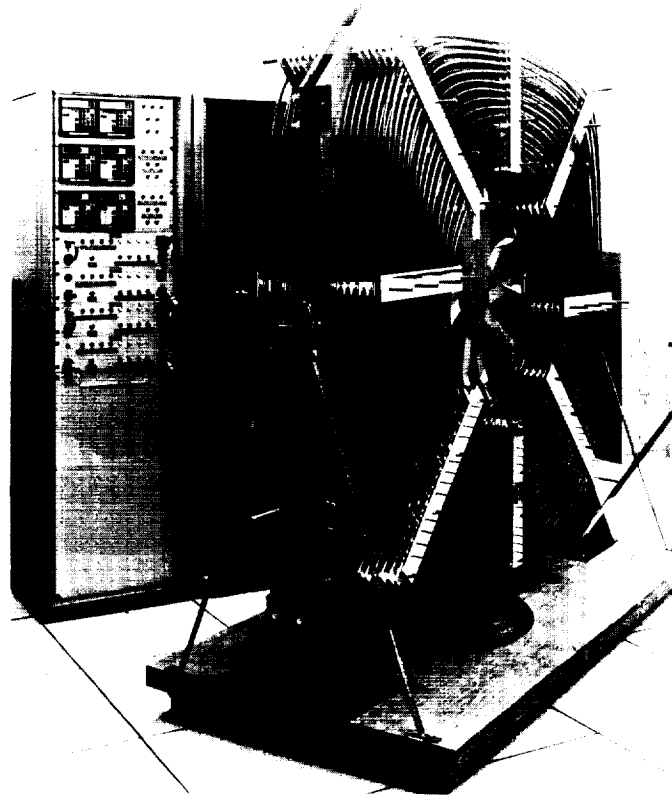

Fig. 5. Test rack for fiber-optic cable.

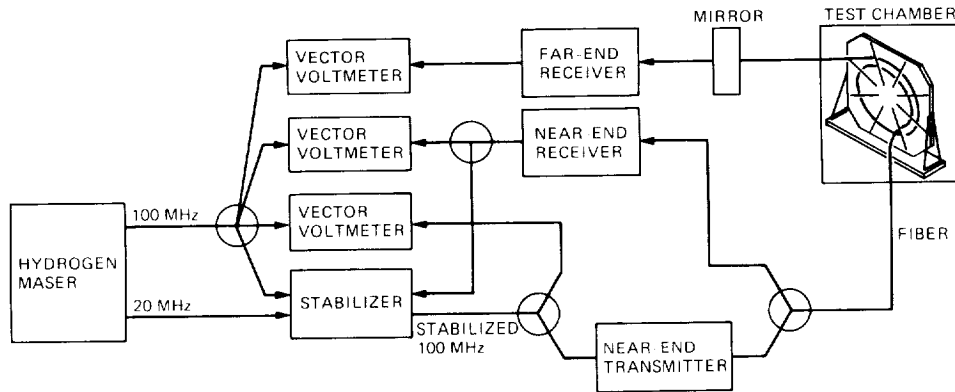

Fig. 6. Fiber-optic stabilizer measurement setup.

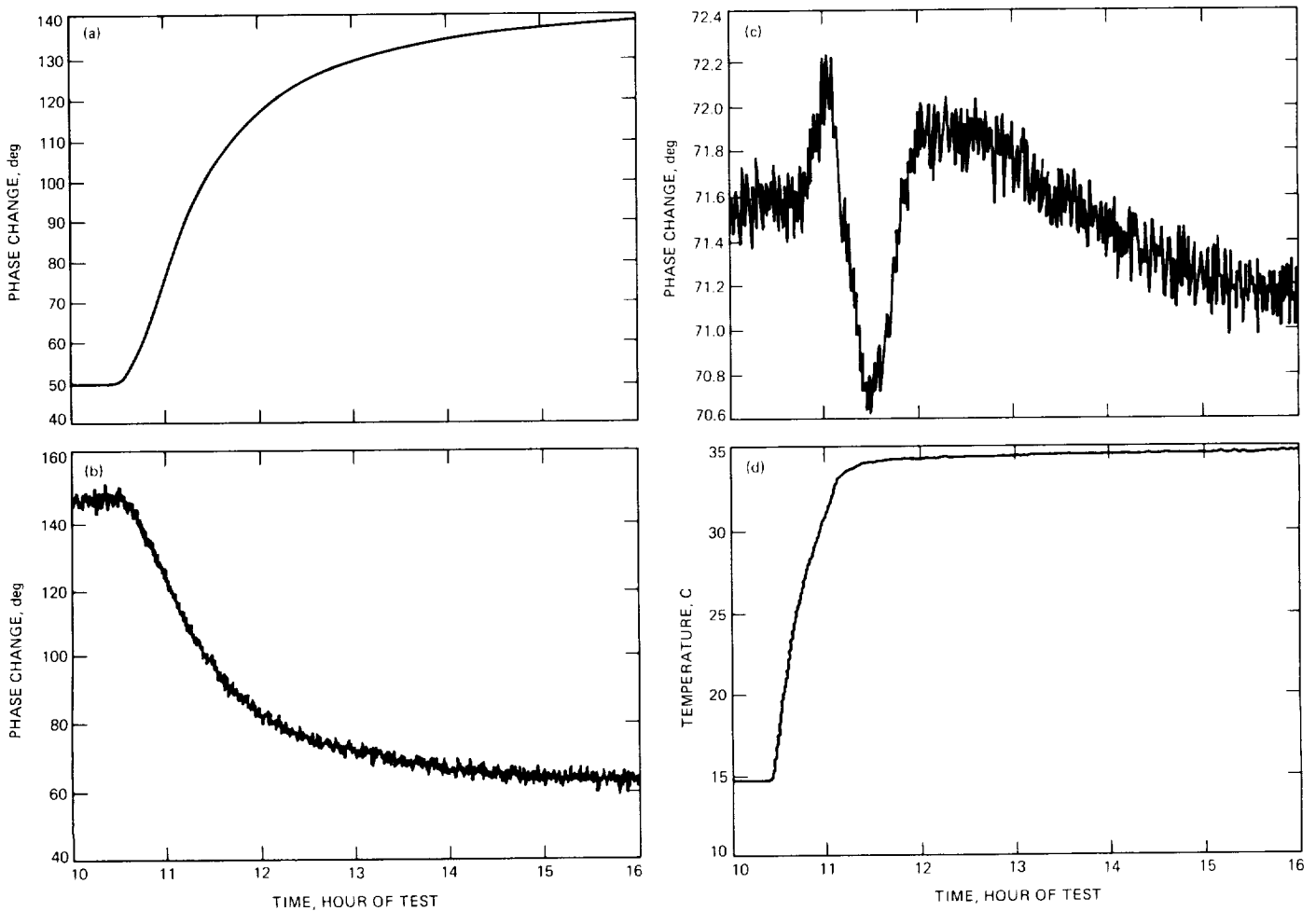

Fig. 7. Fiber-optic test results, phase step change in temperature 15 to 35 °C: (a) reference unit (near-end) transmitter; (b) reference unit (near-end) receiver; (c) remote unit (far-end) receiver; (d) test chamber temperature.

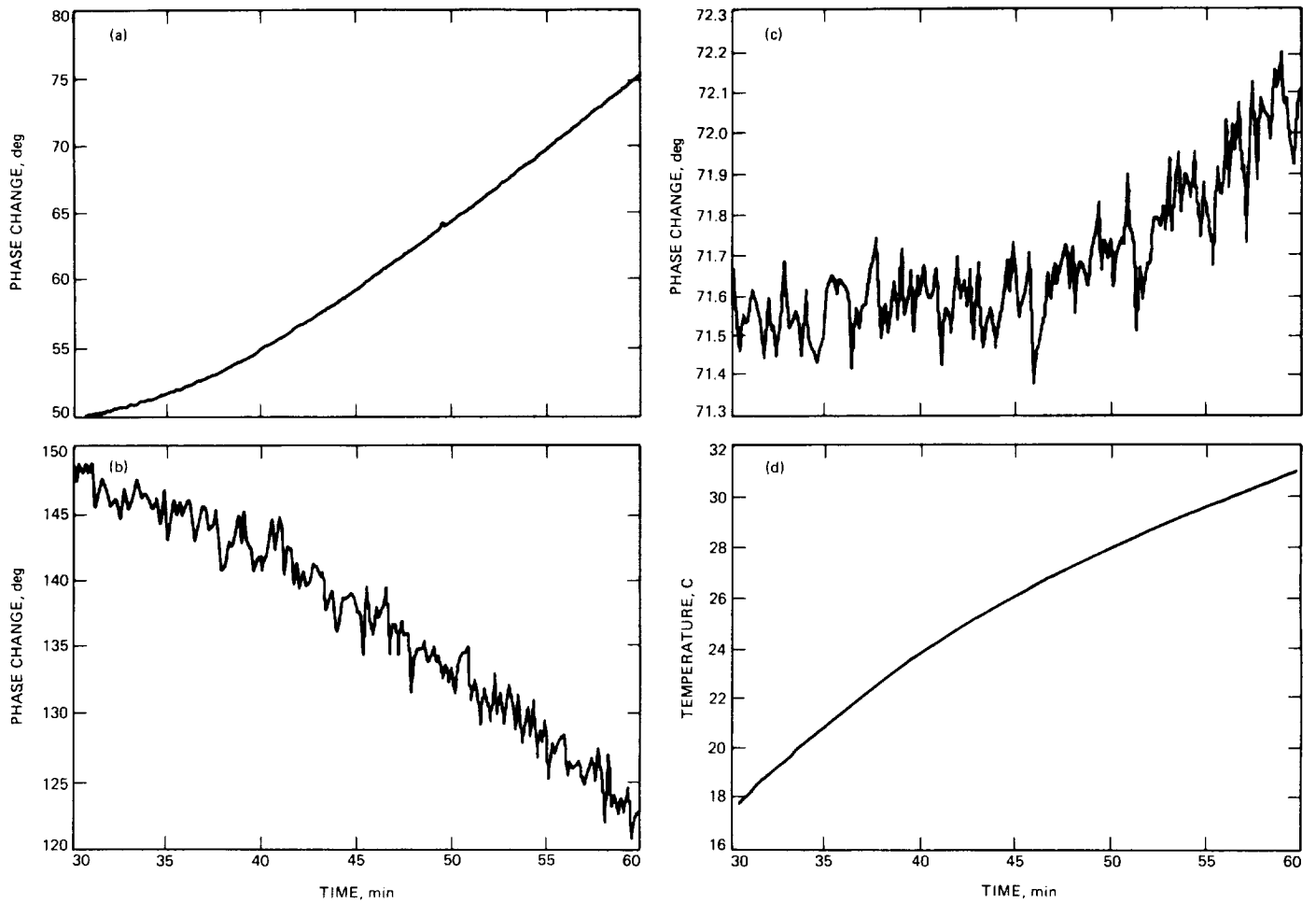

Fig. 8. Fiber-optic test results during the first hour, phase step change in temperature 15 to 35 °C: (a) reference unit (near-end) transmitter; (b) reference unit (near-end) receiver; (c) remote unit (far-end) receiver; (d) test chamber temperature.

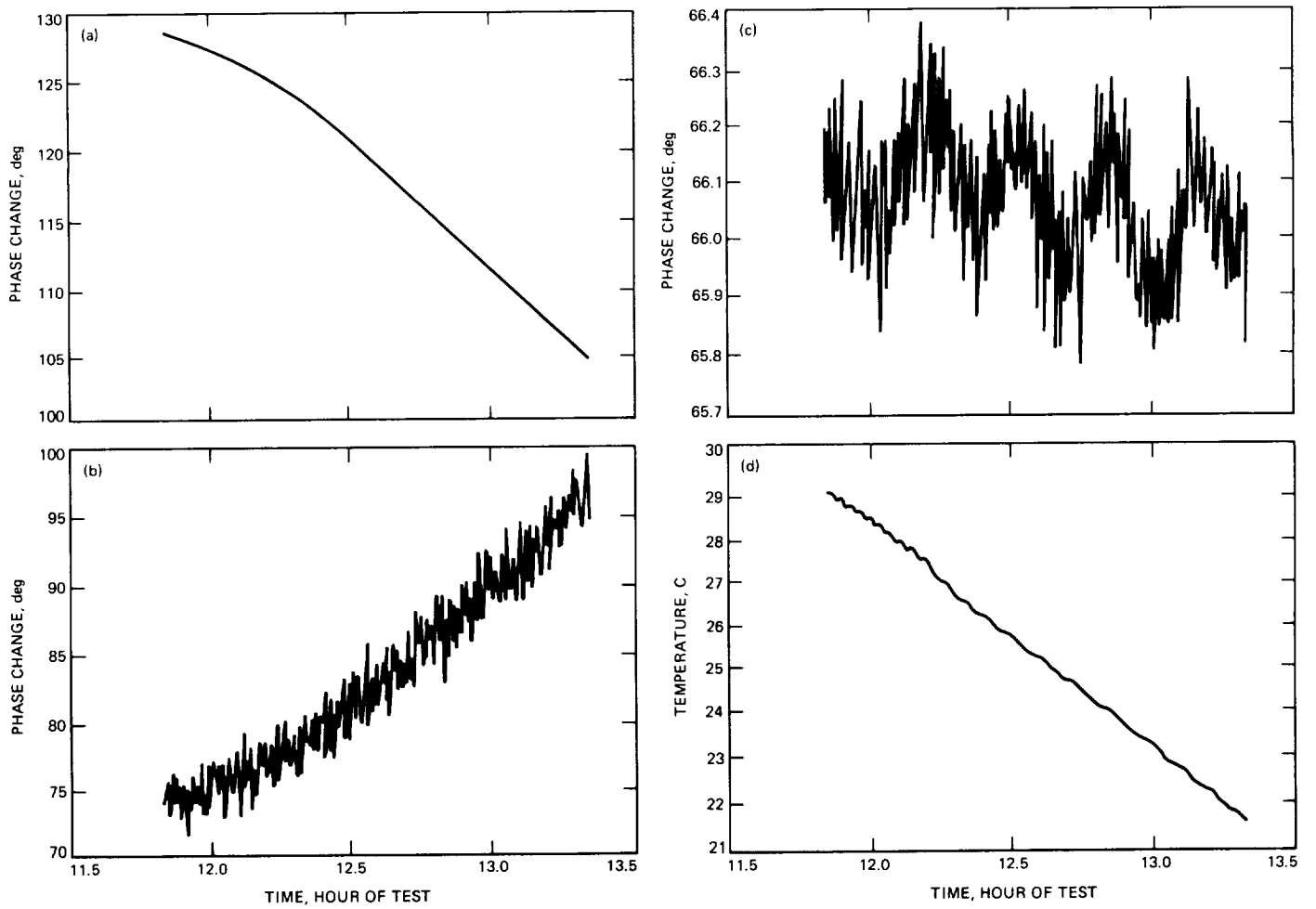

Fig. 9. Fiber-optic test results, linear change in temperature 29 to 22 °C: (a) reference unit (near-end) transmitter; (b) reference unit (near-end) receiver; (c) remote unit (far-end) receiver; (d) test chamber temperature.