

The DSS-14 C-Band Exciter

D. R. Rowan

Radio Frequency and Microwave Subsystems Section

The development and implementation of a C-band exciter for use with the Block IV Receiver-Exciter Subsystem at Deep Space Station 14 (DSS-14) has been completed. The exciter supplements the standard capabilities of the Block IV system by providing a drive signal for the C-band transmitter while generating coherent translation frequencies for C-band (5-GHz) to S-band (2.2- to 2.3-GHz) Doppler extraction, C-band to L-band (1.6-GHz) zero delay measurements, and a level calibrated L-band test signal. Exciter functions are described, and a general explanation and description of the C-band uplink controller is presented.

I. Introduction

The C-band (5-GHz) exciter was developed to function with the Block IV Receiver-Exciter Subsystem and L-band (1.6-GHz) to S-band (2.2- to 2.3-GHz) upconverter to provide two-way C/L-band Doppler and ranging capabilities. Additional requirements concerning ranging calibration and antenna pointing were met with the development of a C- to L-band portable zero delay device and a C-band downconverter assembly.

The overall functionality of the C-band exciter as it interfaces with the Block IV equipment is discussed in Section II and the detailed hardware designs are explained in subsequent sections.

II. C-Band/Block IV Interfaces and Functional Relationships

The C-band exciter was designed to make use of as much of the Block IV capabilities and hardware as possible. Modifications were performed to the various Block IV assemblies

to allow the C-band interfaces to be installed as shown in Fig. 1. These interfaces allow the following Block IV components to be used by the C-band exciter: S-band exciter reference synthesizer, range phase modulator, S-band exciter multiplier chain, S-band Doppler extractor, and programmable attenuator assembly.

The output of the Block IV exciter reference synthesizer, located in the RCV-421 exciter rack, has been routed to the RF drawer assembly (RCV-492) in the combined uplink control rack (TXR-191). During the Block IV mode of operation, the reference signal is passed through a transfer relay and sent back to the Block IV exciter to resume its normal path. During the C-band mode of operation, the reference signal is sent to a distribution amplifier in the RF drawer assembly, which distributes the reference signal to the C-band uplink components and sends the reference back to the Block IV exciter to be multiplied up to S-band. These control relays are activated by the combined C-band uplink controller and are independent of the Block IV receiver-exciter controller.

The Block IV Doppler translator assembly has been modified to route the S-band Doppler reference signal to the C-band

exciter assembly. During Block IV mode, a relay in the C-band exciter returns the signal to the Block IV Doppler translator, where it continues on its normal path. During the C-band mode, the C-band exciter provides a substitute S-band Doppler reference that is coherently derived from the C-band exciter drive signal. The resulting Doppler that is extracted by the Block IV Subsystem is therefore C- to L-band Doppler.

The Block IV programmable attenuator assembly (RCV-481) has been modified to provide input and output switching relays on the S-band attenuator. These relays are controlled by the C-band uplink controller and allow the S-band attenuator to be used to attenuate the L-band coherent test signal from the C-band exciter. During the Block IV mode, the relays are set to allow the normal S-band translator signal from the Block IV Doppler translator to pass through the programmable attenuator. During the C-band mode, the relays pass the L-band test signal through the S-band attenuator before the signal is sent to the Microwave Subsystem. It should be noted that although the control relays are configured via the C-band controller, the attenuation level of the S-band attenuator is controlled via the Block IV receiver-exciter controller and the desired attenuation level must be set through the LMC console or a local terminal attached to the receiver-exciter controller.

The S-band exciter assembly (RCV-441) has been modified to provide an S-band exciter drive output to the C-band exciter. This signal, along with the exciter reference signal from the RF drawer assembly (RCV-492), is used to synthesize the C-band exciter drive signal. Due to the shared configuration between the Block IV and C-band equipment, the S-band drive signal was arranged so that only one exciter (either S-band or C-band) could be operated at a time. This was accomplished by using an existing Block IV control relay in the S-band exciter assembly (RCV-441K3) that functions to turn the S-band exciter drive on and off. In the OFF position, the relay normally terminates the S-band drive signal into a 50-ohm load. The load was removed and the output was routed through an isolator to a port on the side of the S-band exciter assembly. This output feeds the C-band exciter assembly when the S-band exciter drive is turned off at the Block IV controls. It should be noted that this is the only Block IV/C-band interface relay that is not controlled by the C-band controller. It then becomes an operational responsibility to ensure that the S-band exciter drive is in the OFF state before the C-band mode is entered.

III. C-Band Exciter Drive Generation

The C-band exciter uses the Block IV S-band exciter frequency reference, which is $1/116$ the desired C-band exciter frequency (F_c). The frequency multiplication is accomplished

using hardware in both the Block IV and C-band exciter assemblies as shown in Fig. 2.

In the C-band mode, the exciter reference frequency ($F_c/116$) is directed along two paths to the C-band exciter assembly (RCV-130). The first path is through the RF drawer assembly (RCV-492) in the C-band control rack (TXR-191). The exciter reference is passed through a distribution amplifier and sent to the C-band exciter assembly, located in the antenna. The second path is through the S-band exciter multiplication path, where the reference is multiplied by 48 ($48 F_c/116$).

The C-band exciter assembly then takes the reference frequency from the RF drawer assembly, multiplies it by 68, and mixes the results ($68 F_c/116$) with the output from the S-band exciter ($48 F_c/116$), with the sum of the two frequencies (F_c) being selected at the output. The C-band exciter frequency is then passed through several stages of amplification to achieve the desired output.

IV. C-Band Exciter Functions

A. Coherent L-Band Test Signal

The C-band exciter provides a coherent C- to L-band test signal at a fixed level that is subsequently passed through the RCV-481 programmable attenuator assembly, allowing level control. The L-band test signal is generated by mixing the C-band exciter frequency (F_c) with a coherently generated conversion frequency ($453 F_c/681$) to create the desired output ($228 F_c/681$).

The RCV-130A4 coherent translator module in the C-band exciter provides the mixing and selection of the frequencies. Two sources of C-band (F_c) signal are provided for conversion, and selection is determined by the operator at the uplink control rack (TXR-191). A sample of the exciter output drive is provided by a coupler in the A3 exciter mixer module, and a sample of the C-band transmitter output is provided by a high-power coupler in the Microwave Subsystem. Either of these sources may be selected to be converted to L-band.

The conversion frequency ($453 F_c/681$) is generated in the C-band exciter using the exciter reference ($F_c/116$) as shown in Fig. 2. The reference is first passed through the A6 frequency shifter module, where it is multiplied by $4379/681$. This output is multiplied by the X12 frequency multiplier in the A7 module to achieve the $453 F_c/681$ required. This output is sent to the A4 coherent translator module, where the C- to L-band conversion occurs.

B. Zero Delay Reference Signal

To provide an external C- to L-band conversion frequency to be used by the C- to L-band portable zero delay device

(C-PZDD), an additional output of the A7-X12 frequency multiplier module is provided to a port on the C-band exciter assembly. The conversion frequency ($453 F_c/681$) is used by the C-PZDD to convert the output of the C-band transmitter signal to L-band in the same manner as the coherent translator in the C-band exciter. The C-PZDD is a calibrated device that is used to determine the equipment delays in the C-band uplink/L-band downlink for ranging calibrations.

C. C- to S-Band Doppler Reference Signal

During the Block IV mode of operation, the S-band Doppler reference from the Block IV Doppler translator assembly (RCV-431) is routed through the C-band exciter assembly (RCV-130) as shown in Fig. 1. During the C-band mode of operation, the Block IV Doppler reference signal is eliminated and a coherent C- to S-band Doppler reference is generated by the C-band exciter and sent to the Block IV Doppler translator assembly.

The L- to S-band upconverter assembly (RCV-103) is used to translate incoming L-band receive frequencies to S-band (Fig. 3); the S-band signal is sent to a Block IV receiver. With the receiver locked to the L- to S-band signal, the local oscillator from the receiver can then be used by the Block IV Doppler translator assembly (RCV-431) to extract the C- to L-band Doppler from the C- to S-band Doppler reference.

The C- to S-band Doppler reference is generated in the C-band exciter using the exciter reference frequency ($F_c/116$) as shown in Fig. 2. The exciter reference is split by the A6 frequency shifter module and sent to several outputs. An output ($F_c/116$) is provided to the A8-X116 frequency multiplier, which creates an equivalent C-band exciter frequency (F_c). The C-band output is sent to the A9 Doppler reference generator, where it is mixed with a C- to L-band conversion frequency ($453 F_c/681$) from the A7-X12 frequency multiplier. The L-band output ($228 F_c/681$) is mixed with the output of the A11-X31 frequency multiplier (620 MHz) to create the S-band Doppler reference signal.

V. Portable Zero Delay Device

To provide a method of measuring the ranging equipment delays in the C- to L-band link, a calibrated zero delay device was constructed. The device performs essentially the same task as the C- to L-band test translator in the exciter by taking a sample of the uplink C-band signal and coherently translating the signal to L-band, where it is injected into the receive path. Since the delays of the C-PZDD have been measured and are known, its contribution to the overall delay of the link can be eliminated, with the remaining delay being attributed to the station equipment.

The C-PZDD is connected into the C-band exciter/Block IV receiver-exciter as shown in Fig. 4. A sample of the transmitter's C-band output (F_c) is taken off a high-power coupler and mixed with the zero delay output ($453 F_c/681$) from the C-band exciter. The difference of the two inputs ($228 F_c/681$) is selected by a filter and sent to a coupler that injects the signal into the L-band receive path.

VI. C-Band Converter Assembly

To help refine the pointing accuracy of the antenna during C-band operations, a C-band converter assembly was provided to allow the antenna pointing to be evaluated at C-band frequencies. The converter accepts a C-band spectrum and downconverts the signals to an IF centered around 200 MHz. This 200-MHz IF is sent to a square law detector, where the noise power in the spectrum is measured. This allows the antenna to be trained upon a known C-band noise source using the square law detector to fine tune the pointing of the antenna by maximizing the signal strength. The antenna position coordinates can then be interpreted using the known location of the celestial source.

VII. Controller

The C-band uplink controller (HP Vectra Computer) was conceived as a stand-alone system providing monitor and control functions from a combined C-band uplink control rack (TXR-191) located in the SPC-10 area. The controller was designed to configure all the new C-band equipment as well as provide status indications. The C-band controller manipulates the exciter, microwave, and transmitter components of the C-band uplink (Fig. 5), but cannot monitor or control any of the subsystems interfacing with those assemblies due to the lack of an LMC/CMC interface.

The subassemblies of the C-band uplink are designed to interface with a commercial Hewlett-Packard data acquisition unit (DAU) that provides monitor and control of the assemblies. A DAU is located in the antenna and relays information to and from the controller in the SPC area via a fiber optic system. An additional DAU in the control rack provides monitor and control of the SPC-located equipment.

VIII. Physical Configurations

The C-band exciter assembly (RCV-130) is housed in a single wall-mounted Hoffman enclosure that measures approximately 30 in. by 24 in. by 9 in. The enclosure contains the RF modules, and associated monitor, control, and power supply hardware as shown in Fig. 2. Interfaces to the box are made

via feedthrough connectors mounted through an interface plate in the side of the box. Multi-pin connectors provide monitor and control interfaces and N-type connectors provide RF ports.

The RF drawer assembly (RCV-492) and the power supply drawer assembly (RCV-493) are both mounted in the combined uplink control rack (TXR-191). The RF connections to the RF drawer assembly are accomplished through an interface plate on the bottom of the TXR-191 rack assembly.

The C-band converter assembly (RCV-129) consists of a single wall-mounted Hoffman enclosure that measures approximately 16 in. by 15 in. by 6 in. The enclosure contains the RF downconverter module and power supply. The RF ports and monitor connections are provided through an interface plate on the side of the assembly.

The C-band portable zero delay device is housed in a weather-tight portable box that contains the RF hardware and a set of three cables for use during the calibration tests. During the use of the device, the assembly is placed in the proximity of the C-band exciter so that connections between the exciter, microwave couplers, and the C-PZDD can be made using the provided cables.

IX. Conclusions

The C-band exciter assemblies were installed at DSS-14 during late December 1988 and are presently undergoing engineering tests. Due to the shared configuration of the C-band uplink controller, the overall C-band uplink assemblies will be tested together when the final acceptance tests are performed. Several tracks of the Phobos spacecraft have been accomplished and the system has met its functional requirements.

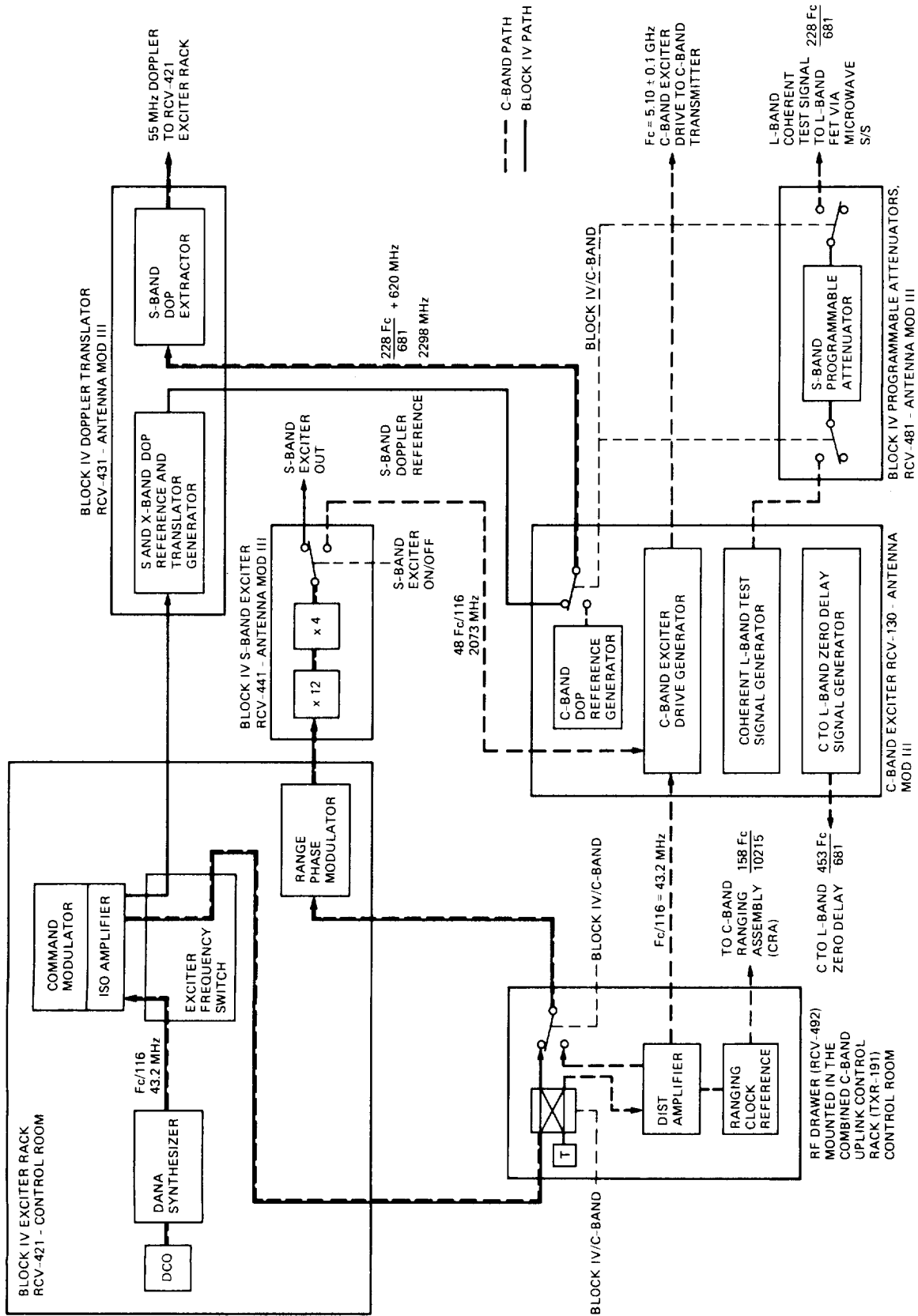

Fig. 1. Block IV receiver-exciter and C-band exciter interfaces.

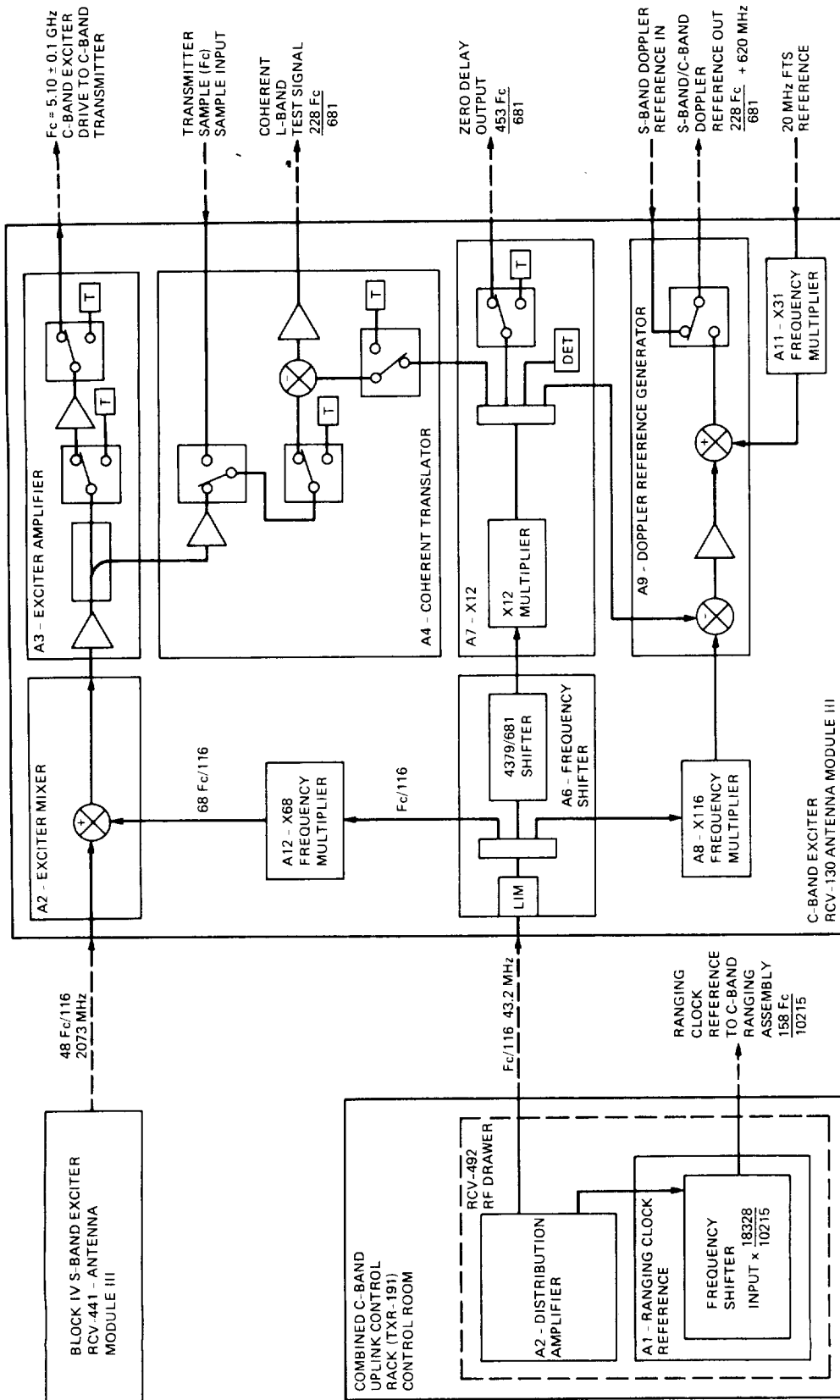

Fig. 2. C-band exciter signal generation.

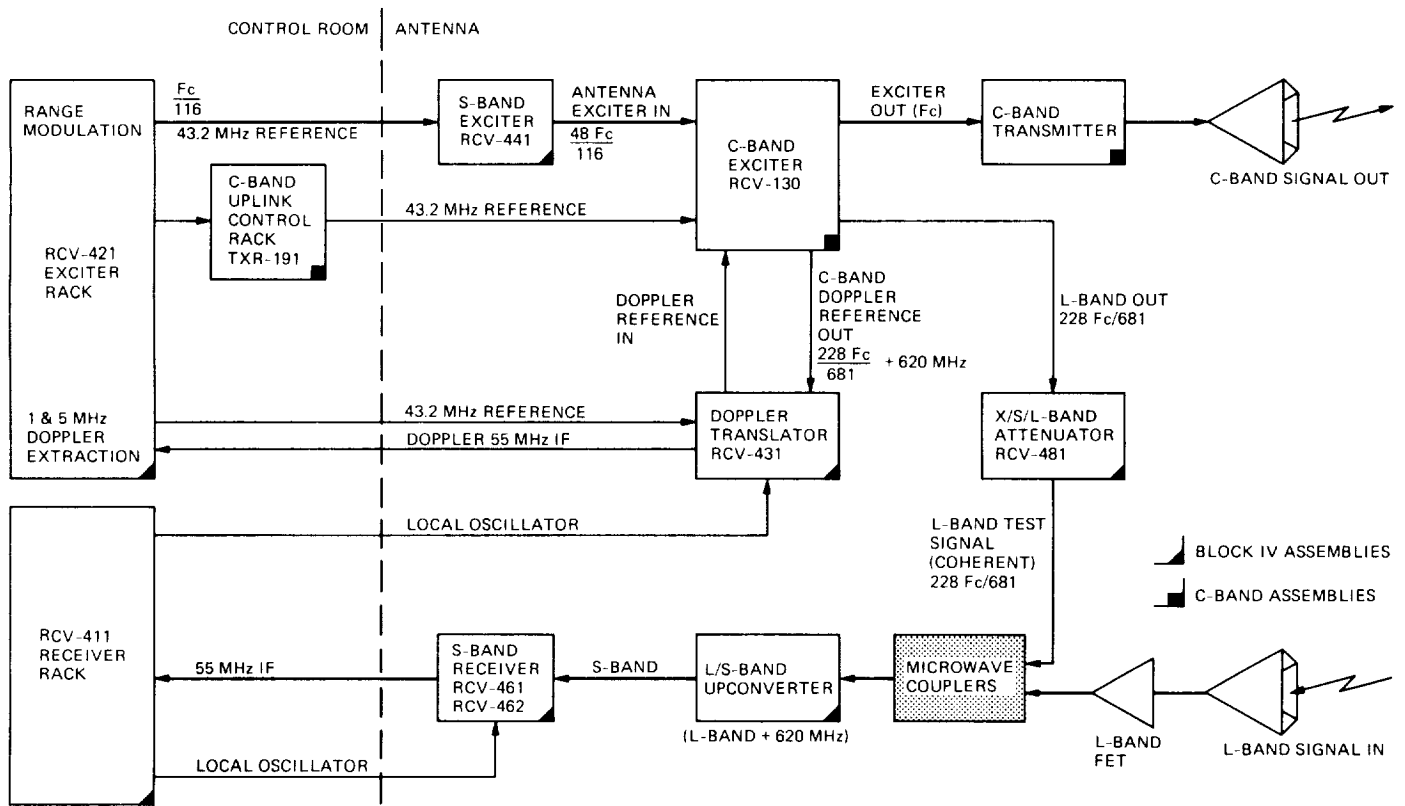

Fig. 3. C-band uplink and L-band downlink signal path.

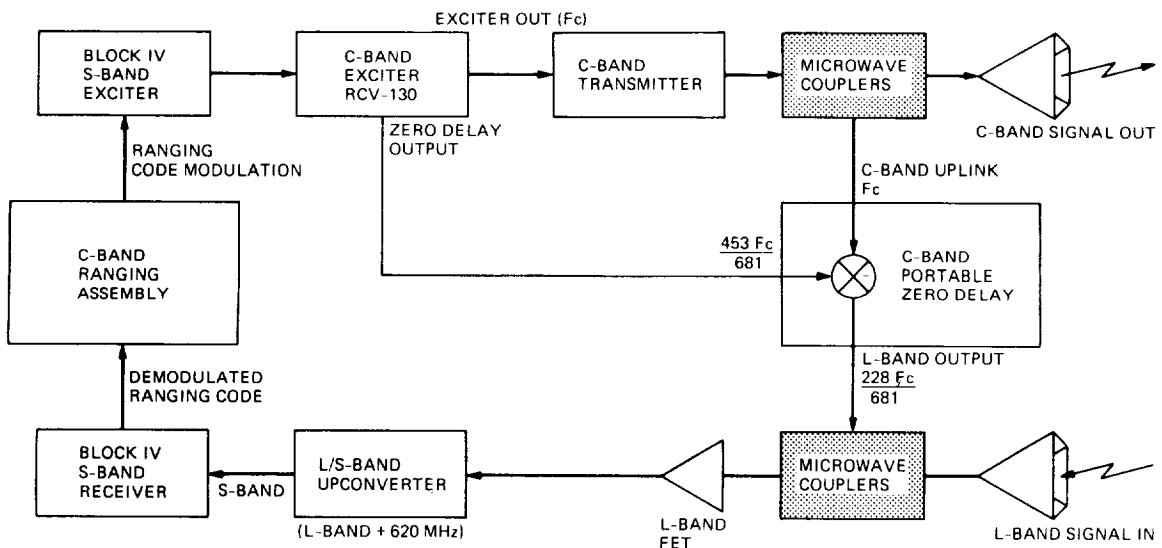

Fig. 4. C-band portable zero delay ranging.

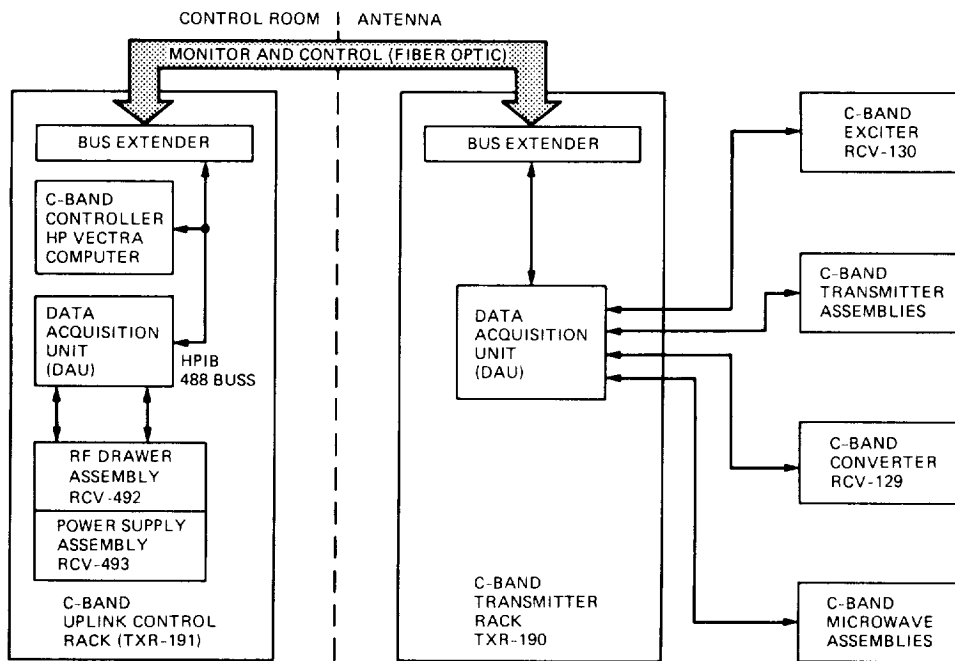

Fig. 5. C-band controller block diagram.