

NASA CR-185308

X-RAY SPECTROSCOPY OF THE SSME PLUME

(NASA-CR-185308) X-RAY SPECTROSCOPY OF THE
SSME PLUME Report, May - Oct. 1988
(Sverdrup Technology) 20 p C5CL 21H

N90-10168

Unclas
G3/20 0224570

Dan Olive

NOVEMBER 1988

NASA

X-RAY SPECTROSCOPY OF THE SSME PLUME

Dan Olive *Sverdrup*

November 1988

acknowledgment
Prepared Under TWR CB-RADV by
Sverdrup Technology, Inc.
SSC Group

for

JOHN C. STENNIS SPACE CENTER
NATIONAL AERONAUTICS AND SPACE ADMINISTRATION
STENNIS SPACE CENTER, MISSISSIPPI 39529

Done under contract # NAS13-290

SUMMARY

The first x-ray spectrum of the SSME plume was obtained during a 300 second test firing on the A-1 Test Stand on October 3, 1988. The spectrometer used covered a range of 2Kev through 41 Kev. Data was integrated throughout the full 300 seconds of burn time. The spectrum is dominated by a prominent line feature which peaks at 34.5 Kev, equivalent to a wavelength of 0.36 angstroms. The physical process responsible for generating this essentially monochromatic radiation has not been determined. As of this writing plans to repeat the experiment have been frustrated by failure of the x-ray detector.

SYMBOLS

- A - Angstrom (10^{-10} meters) unit of measure for wavelengths
- ev - Electron Volt - unit of measurement for energy
- FET - Field Effect Transistor
- Ge - Germanium
- Kev - Kiloelectron Volt (10^3 ev)
- SiLi - Silicon Lithium
- TCC - Test Control Complex

November 1988

CDDF REPORT

X-Ray Spectroscopy of the SSME Plume

TWR # CB-RADV

INTRODUCTION

Much data has been collected on the electromagnetic emissions of the Space Shuttle Main Engine (SSME) in the ultra-violet (UV), visible (VIS), and near infrared (IR) portions of the spectrum. This report summarizes initial efforts intended to extend the database above the UV into the x-ray portion of the spectrum.

BACKGROUND

Agreement was reached with the benefitor that TWR #CB-RADV would concentrate on collecting data in the X-ray portion of the spectrum. It is known through earlier experiments that the plume does emit in the soft x-ray range of 10 Kev through 60 Kev. The efforts under this TWR were designed to yield spectra over this range to evaluate the feasibility of deriving real-time SSME "health-monitoring" data in the soft x-ray portion of the EM spectrum.

ACCOMPLISHMENTS TO DATE

Initial efforts were concentrated on acquiring and evaluating technical data on currently available x-ray detection instrumentation. A telephone market survey was conducted wherein manufacturers of x-ray detection equipment were polled to determine if they could supply equipment which would provide the desired spectra. A total of 16 different vendors were contacted, five of whom mailed technical data packages.

Concurrent with the market survey, the physics of x-ray spectroscopy was reviewed with particular emphasis on detection methods. Detectors employing the various detection methods were evaluated for the specific task of acquiring spectra of the SSME plume emission. Of particular concern was the capability of the detectors to function properly in the severe acoustic, vibrational and temperature environment associated with the SSME firing.

All detection methods rely on the capacity of x-rays to ionize matter. The amount of ionization is proportional to the original energy of the x-ray photon, or inversely proportional to the wavelength.

Available detector types include: 1) Proportional Chambers
2) Scintillation Counters
3) Solid State Detectors

In proportional chambers the chamber is filled with "inert" gases, typically argon (Figure 1 shows a typical chamber). A very thin wire in the center of the chamber is maintained at a high voltage. Ionization produced by x-ray photons is multiplied by "avalanche" in the vicinity of the wire. The resulting pulse, proportional to the X-ray photon energy, is collected. Pulses are sorted by pulse height analyzers and the resulting histogram of number of pulses versus pulse height yields the desired spectrum.

In scintillation counters special materials are used which fluoresce due to recombination of electrons freed by ionization with the atoms in the material. Figure 2 shows a typical scintillator, in this case doped sodium iodide, which is optically coupled to a PM tube. The fluorescence is within the portion of the EM spectrum which is detectable by photomultiplier (PM) tubes. Pulse height analysis of the resultant pulses from the PM tubes again yields the desired spectrum.

Solid state detectors are operated so that the x-ray induced ionization is directly collected from specially doped semiconductor materials. These detectors must be operated at very low cryogenic temperatures so that thermally generated noise is minimized. They are cooled with liquid nitrogen (LN_2) and are operated within a hard vacuum to insulate them from ambient heat. Figure 3 depicts a typical solid state detector assembly with integral preamp FET.

All types of x-ray detectors are, to some extent, microphonic. Thus, a certain amount of the signal from them will be attributable to acoustic and/or vibrational input.

All the x-ray detectors are also sensitive to charged particles as well as EM radiation outside the x-ray region. For this reason, all have "windows" of material (typically beryllium) which will absorb or stop these particles and are opaque to EM radiation at longer wavelengths. The thickness and material type of this window sets the lower limit of x-ray photon energies which can be detected. Figures 4 A & B show x-ray transmission through various windows. Here, the trade-off is window strength, required to protect the detector, and the requirement to minimize window thickness so as to obtain as much of the lower end of the spectrum as possible.

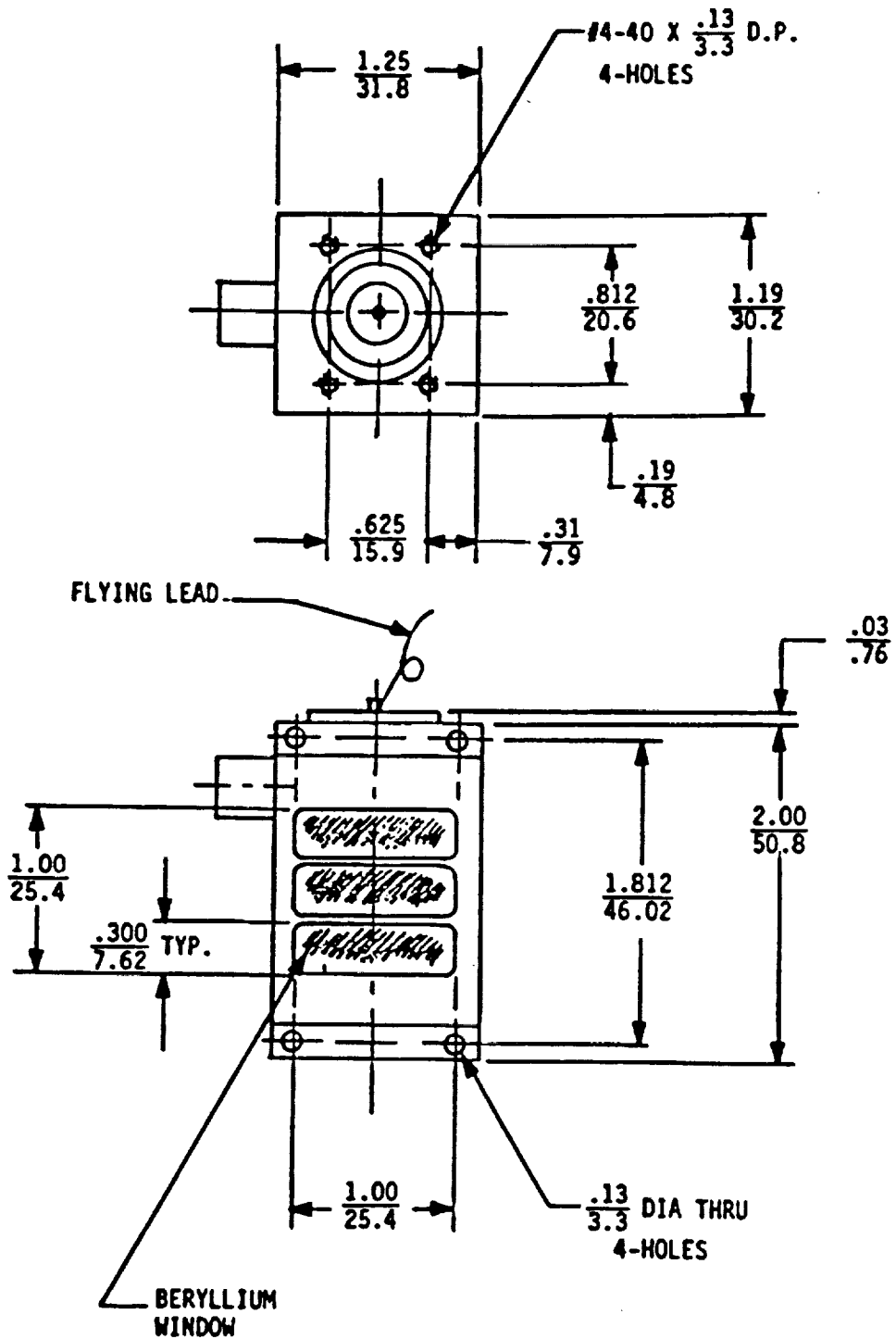

FIGURE 1 - PROPORTIONAL CHAMBER (REF. 1)

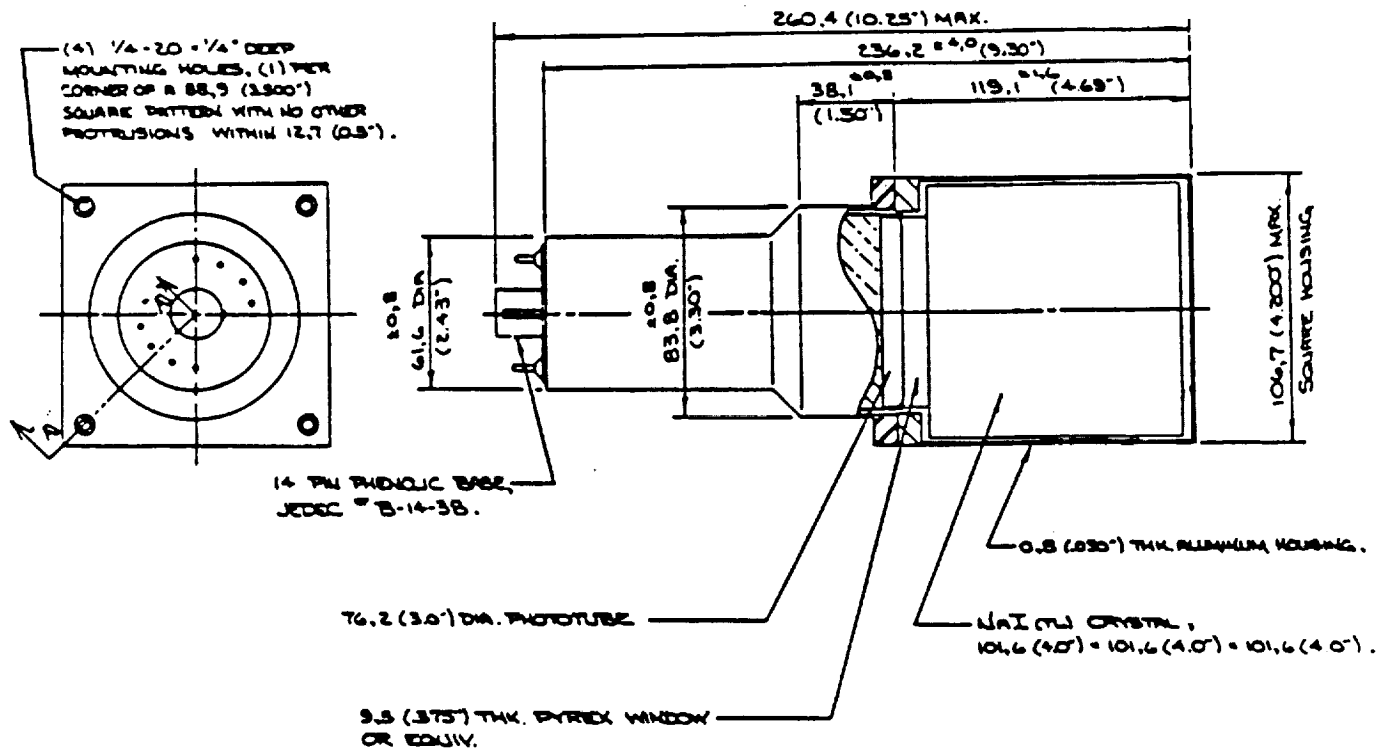

FIGURE 2 - SCINTILLATION COUNTER (REF. 2)

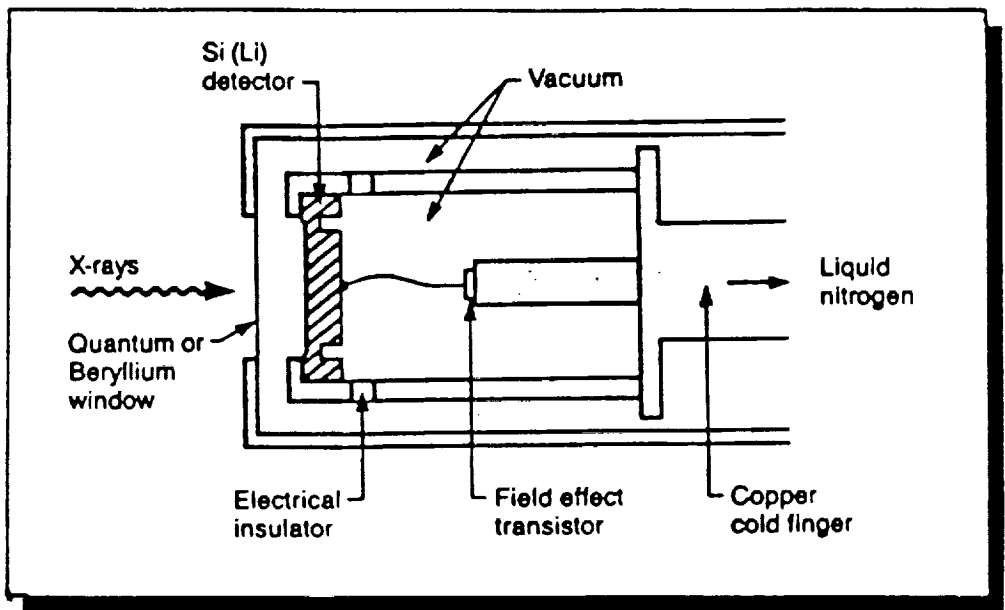

FIGURE 3 - SOLID STATE DETECTOR (REF. 3)

X-RAY & GAMMA RAY TRANSMISSION THROUGH BICRON DETECTOR WINDOWS

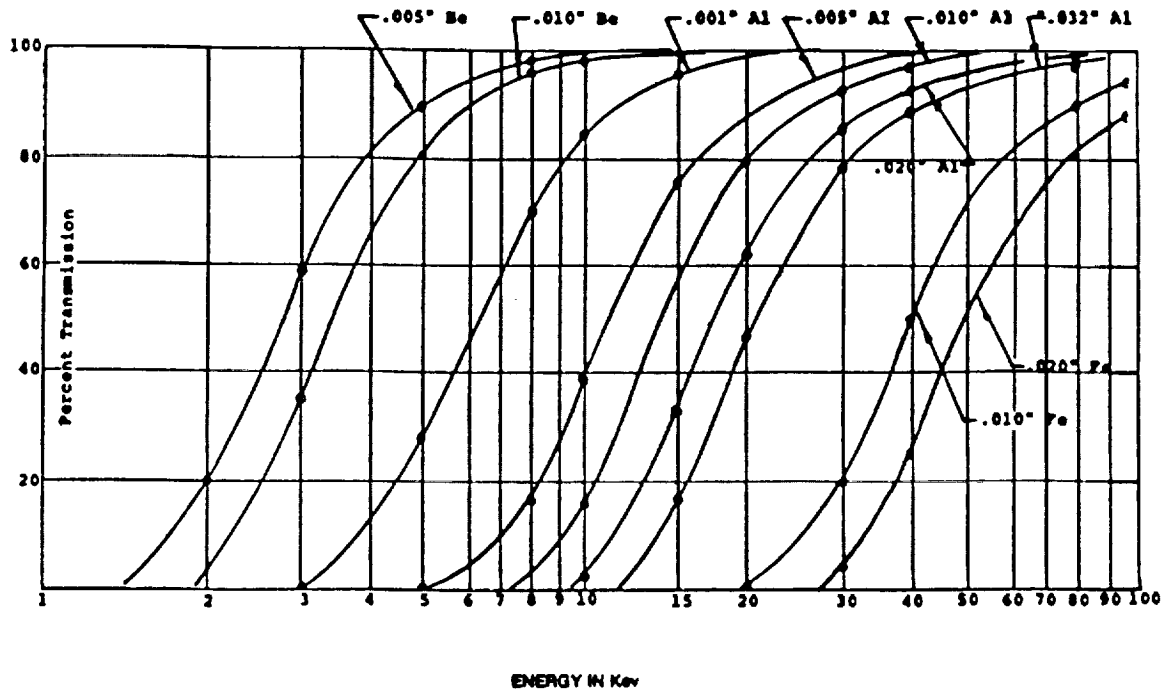

FIGURE 4A (REF. 2)

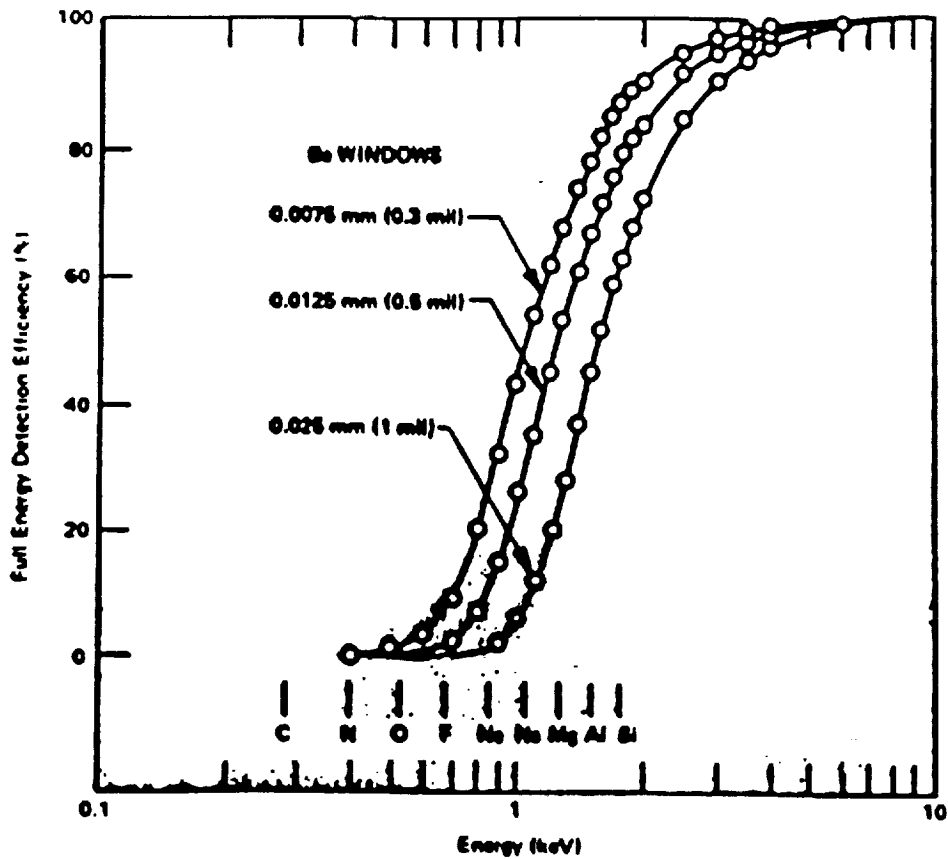

FIGURE 4B (REF. 4)

ORIGINAL PAGE IS
OF POOR QUALITY

The upper end of the attainable spectrum is a function of the detector material and its thickness. Higher energy photons are more "penetrating" and require more thickness for any material to absorb the energy. In this respect, the Germanium solid-state detector performs better than the silicon (SiLi) or scintillators. Figures 5 A & B show the reduction in absorption efficiency as a function of photon energy.

SYSTEM CONFIGURATION

The equipment utilized in obtaining the x-ray spectrum was leased for a 60 day period from Applied Detector Corporation of Fresno, California. Figure 6 is a block diagram of this system.

The detector is the Applied Detector Corporation Model ADC 400 x-ray spectrometer with a model PS-3 power supply. Characteristics of this spectrometer are summarized below.

- Detector type: Germanium, Solid State, 5mm dia.
- Window: 0.005" Beryllium
- Range: \approx 4 Kev thru 200 Kev
- Resolution: 180 ev @ 5.9 Kev; 550-600 ev @ 122 Kev
- Low Noise Preamp, built into detector assembly
- LN₂ Dewar hold time: 8-10 hours
- Size: 3" dia. X 18" long
- Compact, sturdy construction

The scaling amplifier is a California American Scientific Instrument X-ray Pulse Processor. This amplifier permitted adjustment of gain in order to set the upper energy limit for ten volt output pulses to match the input range of the pulse height analyzer.

Sorting of the pulses by amplitude was accomplished by the Model 1024 D Pulse Height Analyzer (1024 channels) from Nucleus Inc. of Oak Ridge, Tenn. The resultant spectra were displayed on a CRT with a controlled cursor to enable digital readout of accumulated counts by channel number.

The detector was housed in a section of eight inch diameter steel pipe fabricated on-site. It was cushioned in acoustic foam rubber and protected to some extent by an aluminum endplate with a small hole to admit x-rays to the detector window.

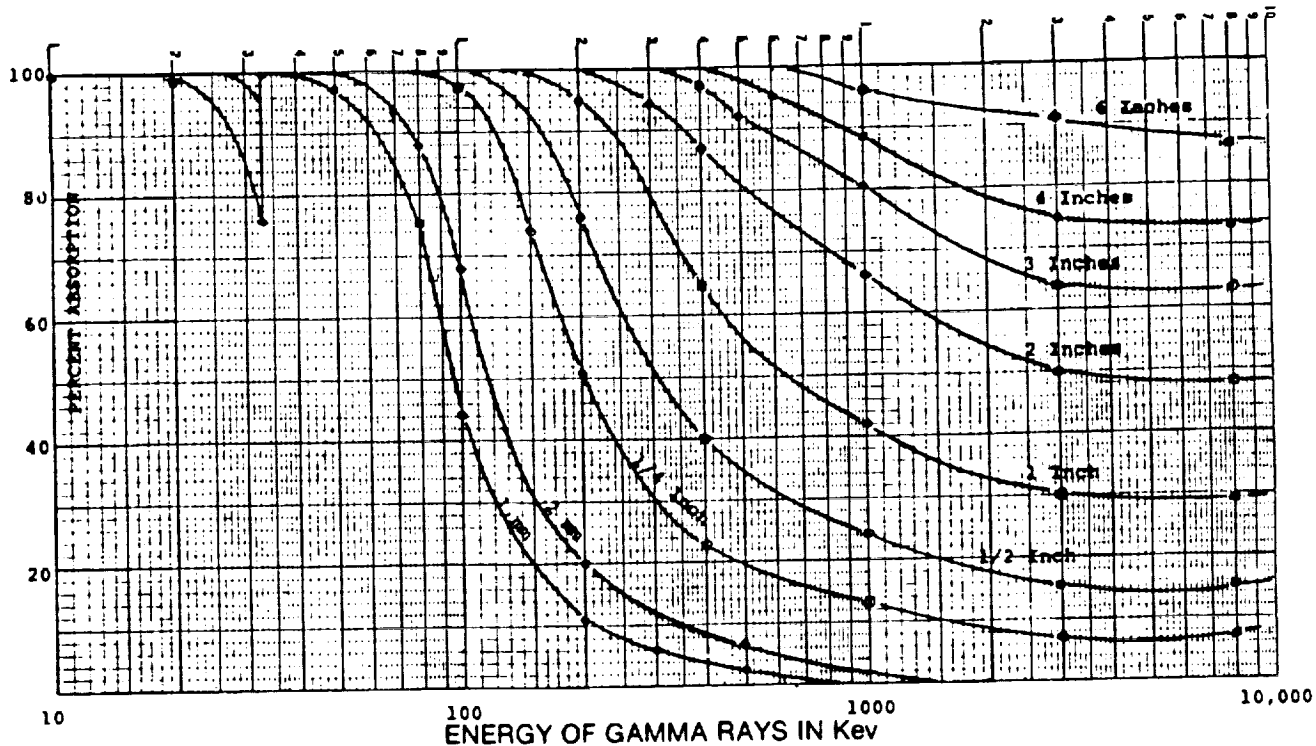

ABSORPTION EFFICIENCY NaI(Tl)

FIGURE 5A (REF. 2)

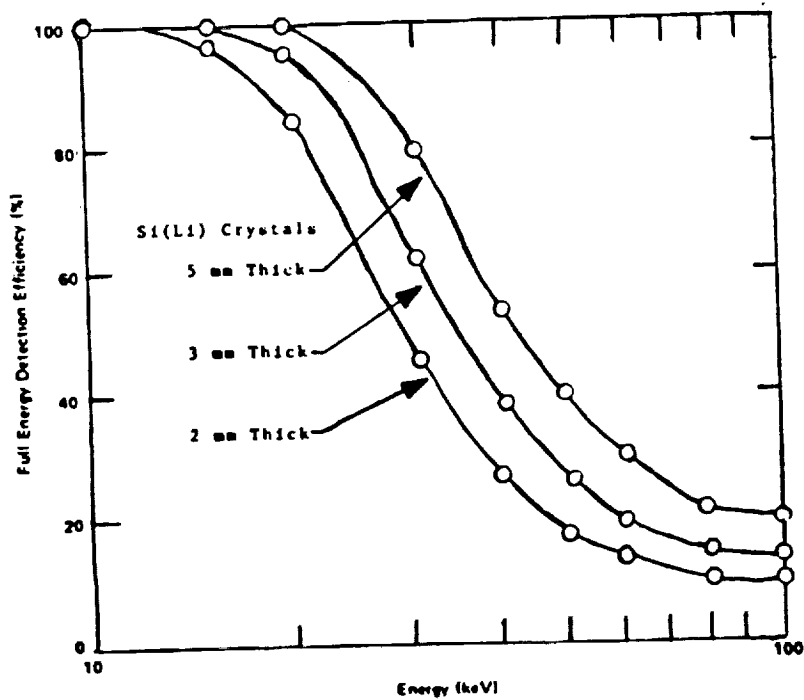
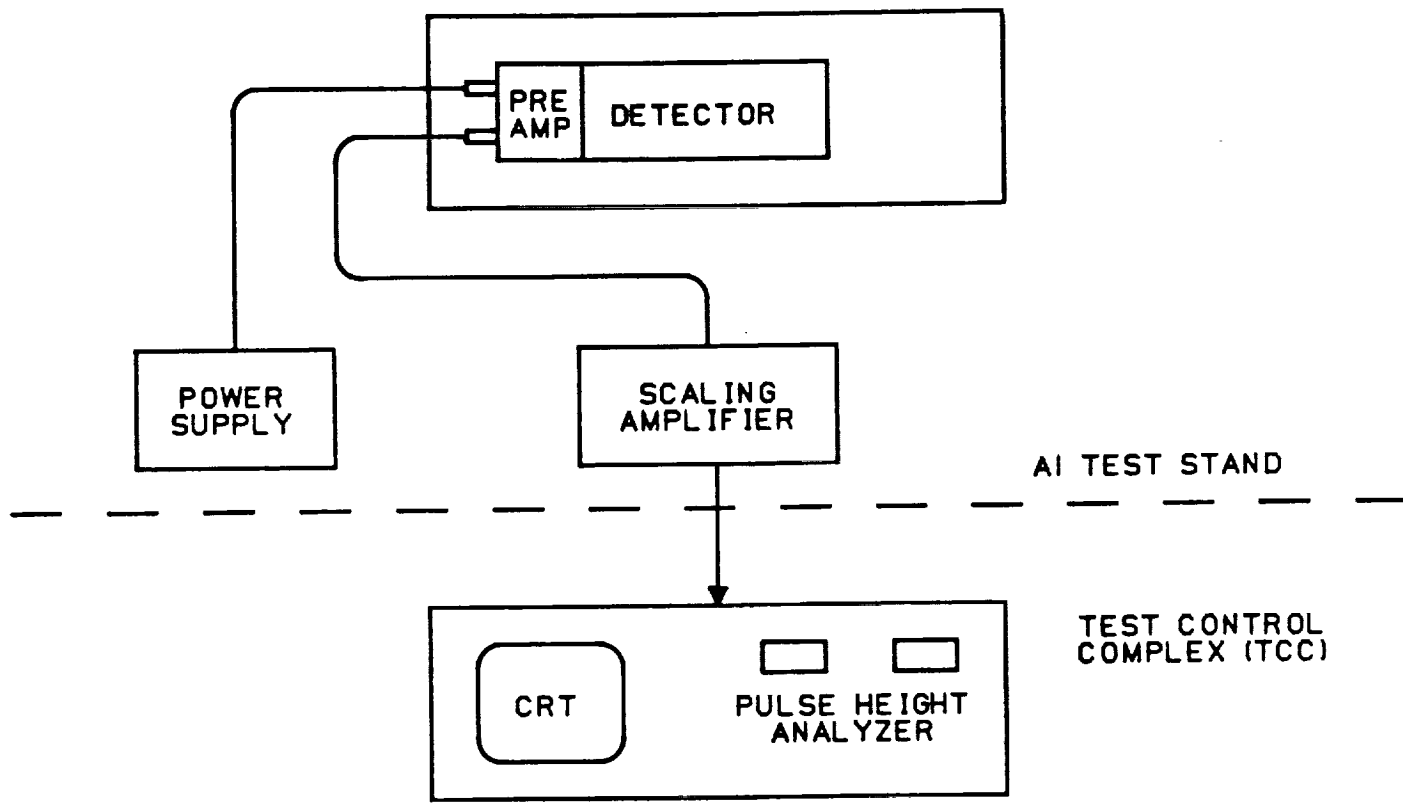

FIGURE 5B (REF. 4)

ORIGINAL PAGE IS OF POOR QUALITY



SYSTEM CONFIGURATION

FIGURE 6

This assembly was mounted on the southwest slam ring mounting bracket on the A-1 Test Stand. This location was chosen because it was the closest practical position to the plume where the assembly would not interfere with normal operations.

The power supply and scaling amplifier were located within the hardstand at level 4. Amplifier output pulses were routed over existing coaxial cable to the TCC where the pulse height analyzer could be operated and monitored during engine tests.

PROCEDURE

Operation of the system was verified by placing a Cobalt 60 source at the housing window and checking the resultant spectra. This also yielded pretest calibration spectra which compensated for the unknown cable attenuation between the A-1 Stand and the TCC.

The single SSME spectrum was obtained on October 3, 1988. This 300 second burn yielded the spectrum shown in Figure 7.

On the day of the test, additional pretest data was taken to verify proper operation and obtain pretest calibration verification. Background data, integrated over several five to ten minute intervals prior to the burn, showed essentially no counts.

Just prior to ignition the analyzer was started and data accumulated over the full 300 seconds of the burn. The resultant spectrum, with the prominent line emission feature, was unexpected. Prior to the test it was expected that a low level continuum which would decrease in intensity at higher energies would be seen. This is seen in the data with the line feature superimposed.

CALIBRATION ANALYSIS

As noted, the system was calibrated by using a Cobalt 60 source with lines at 5.90 Kev and 6.49 Kev. For the system settings at which the test spectrum was obtained, these lines peaked at bins 125 and 140 respectively. Extrapolation from these readings produce a zero at bin 25 with a bin width of $39\frac{1}{3}$ ev per bin. Thus, adjusting for this offset yields bin numbers of 150 and 165 for the calibration peaks.

$$(39\frac{1}{3}) \text{ ev/bin} \times 150 = 5.90 \text{ Kev}$$

$$(39\frac{1}{3}) \text{ ev/bin} \times 165 = 6.49 \text{ Kev}$$

X-RAY Spectrometer Data

10/04/88

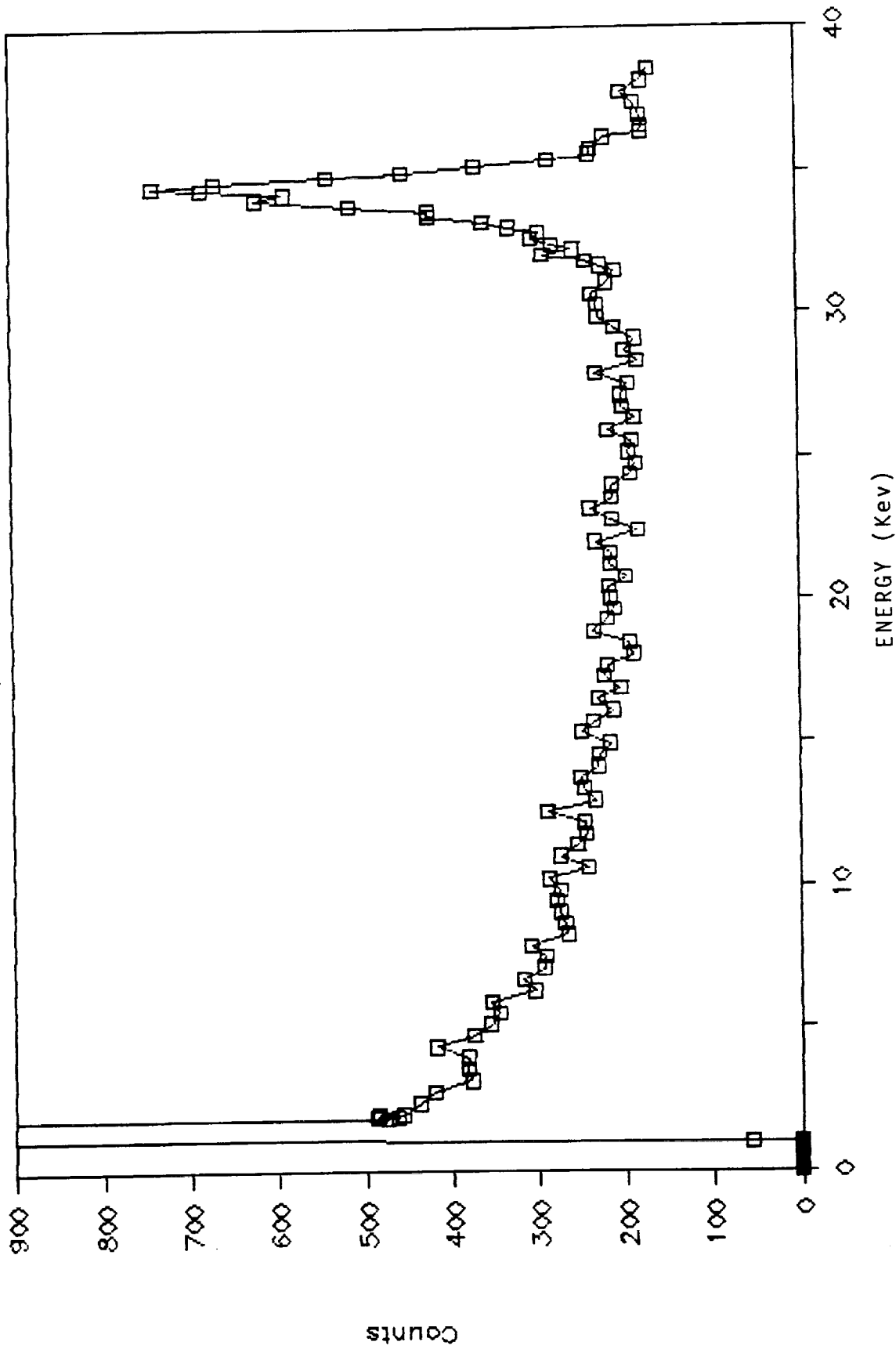

FIGURE 7

The prominent line feature was centered at bin 877, adjusted bin 902, yielding a peak at 35.48 Kev. Utilizing the equation $E = hc/\lambda$, this energy is equivalent to a wavelength of 0.36 .

Data for the plot was laboriously taken for each 10th bin utilizing the cursor. Scope camera photographs of the CRT readout were taken and have been included as Appendix A.

The large "spike" near zero is presumed to be noise, probably acoustically or vibrationally induced. A count of 38,000 was registered in bin 43. No counts were registered in bin 25 or lower.

Attempts to obtain post-test calibration data were delayed until the stand was "safed" and reopened for access. When the calibration source was finally installed the LN₂ dewar was apparently empty. A second attempt the following day was unsuccessful also. The equipment was removed to the electronics lab and checked. All indications pointed to a loss of vacuum in the detector housing, preventing proper cooling of the detector. The detector was returned to the vendor for repair or replacement.

CONCLUSION

The single, prominent feature noted in the only x-ray spectrum of the SSME plume obtained to date is extremely interesting. The author feels strongly that:

- 1) Additional spectra should be taken
- 2) Further efforts be made in analysis of subsequent data in order to understand the origin of the feature.

The lease on the equipment terminates in mid November. It is recommended that the PC-based spectrometer (with analysis software) be procured to permit in-depth analysis of this phenomenon. A verbal quote of \$16,000 was provided by Applied Detector Corp. for this system.

FIGURE REFERENCES

The figures referenced are taken from publicly available manufacturers' brochures and are intended to illustrate typical characteristics of available x-ray detection equipment.

- 1 Cianflone Scientific Instruments Corporation
228 RIDC Park West Drive
Pittsburgh, PA 15275
- 2 Bicron Corporation
12345 Kinsman Road
Newbury, OH 44065
- 3 Kevex Corporation
355 Shorway Rd.
San Carlos, CA 94020
- 4 HNU Systems, Inc.
Oak Ridge Technical Center
271 Midway Road
Oak Ridge, TN 37830

ORIGINAL PAGE
BLACK AND WHITE PHOTOGRAPH

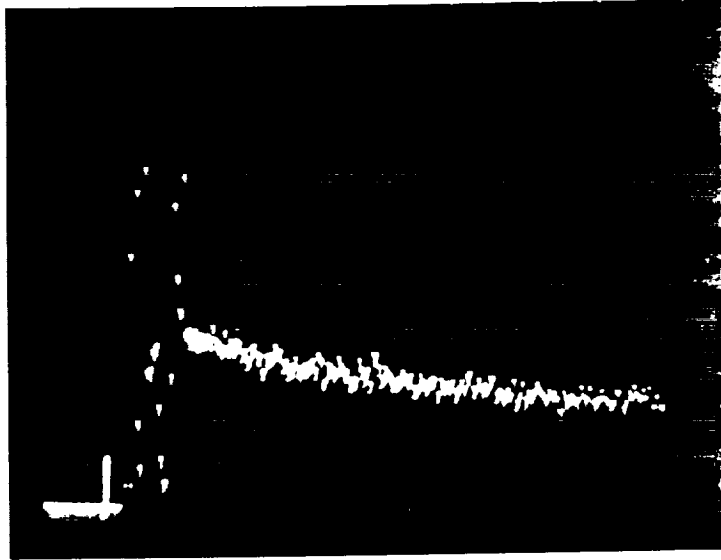

Photo #4

- Expanded horizontal near 0
- Full scale 1,000 counts
- Low energy peak overranged

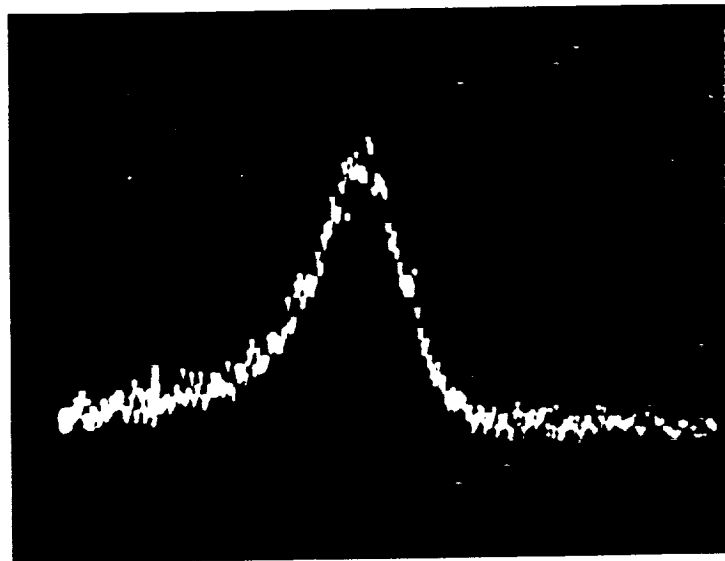

Photo # 5

- Expanded horizontal scale of feature
- Full scale 1,000 counts
- Peak of 738 counts at bin 877

ORIGINAL PAGE
BLACK AND WHITE PHOTOGRAPH

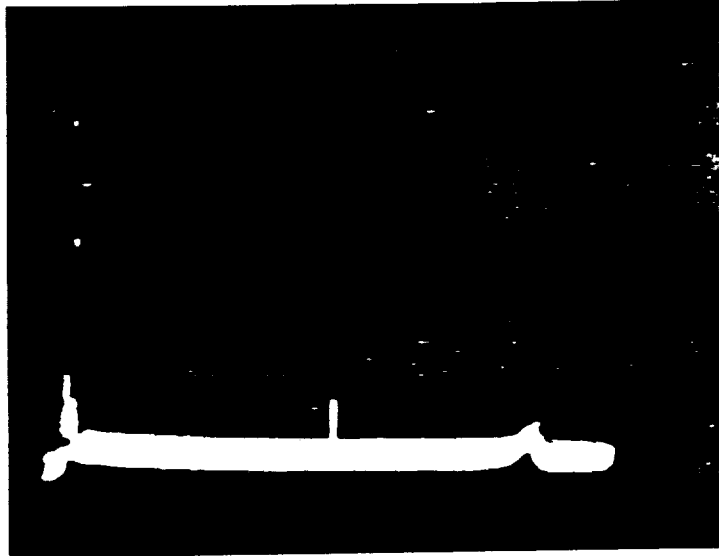

Photo #6

- Full scale 10,000 counts
- Very high (38,000) low energy count
- Cursor at 512 (center)

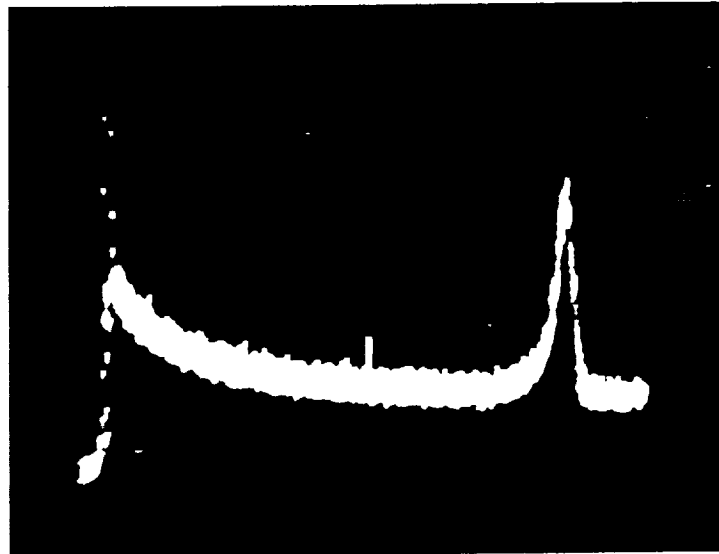

Photo #7

- Full scale 1,000 counts
- Peak of feature at bin 877
- 738 counts at peak
- "Noise" about 50 counts PK-PK
- Continuum about 190-200 counts in neighborhood of peak
- Width of feature (FWHM) about 35 bins or about 1.4 Kev



Report Documentation Page

1. Report No. NASA CR-185308		2. Government Accession No.		3. Recipient's Catalog No.	
4. Title and Subtitle Engine Diagnostics/Soft X-Rays (X-Ray Spectroscopy of the SSME Plume)				5. Report Date November 1988	
				6. Performing Organization Code	
7. Author(s) D. F. Olive				8. Performing Organization Report No.	
				10. Work Unit No.	
9. Performing Organization Name and Address Sverdrup Technology, Inc. Stennis Space Center, MS 39529				11. Contract or Grant No.	
				13. Type of Report and Period Covered Contractor Report May-October 1988	
12. Sponsoring Agency Name and Address National Aeronautics & Space Administration Stennis Space Center, MS 39529				14. Sponsoring Agency Code	
15. Supplementary Notes NASA Technical Monitor: D. J. Chenevert					
16. Abstract In order to examine the potential of using SSME exhaust plume radiation in the soft x-ray spectrum as an early warning system of imminent engine failure, a low-cost, low-risk experiment was devised. An approach was established, equipment was leased, the system was installed and checked out, and data were successfully acquired demonstrating the proof-of-concept. One spectrum measurement of the SSME plume was acquired during a 300 second burn on the A-1 Test Stand. This spectrum showed a prominent, line emission feature at about 34.5 Kev, a result which was not expected, nor can it be explained at this time. If x-ray spectra are to be useful as a means of monitoring nominal engine operation, it will be necessary to explore this region of the EM spectrum in greater detail. The presence of structure in the spectrum indicates that this technology may prove to be useful as an engine health monitoring system.					
17. Key Words (Suggested by Author(s)) X-ray Spectroscopy Engine Health Monitoring Engine Diagnostics Plume Diagnostics			18. Distribution Statement Unclassified--Unlimited Subject Category 20		
19. Security Classif. (of this report) Unclassified		20. Security Classif. (of this page) Unclassified		21. No. of pages 17	22. Price A02