

**NASA Technical Memorandum 101642**  
**AVSCOM Technical Memorandum 89-B-008**

# **INTEGRATED MULTIDISCIPLINARY DESIGN OPTIMIZATION OF ROTORCRAFT**

**Howard M. Adelman and Wayne R. Mantay**

(NASA-TM-101642) INTEGRATED  
MULTIDISCIPLINARY DESIGN OPTIMIZATION OF  
ROTORCRAFT (NASA) 13 p CSCL 01C

N90-10889

Unclas  
G3/05 0237059

**July 1989**

**NASA**

National Aeronautics and  
Space Administration

Langley Research Center  
Hampton, Virginia 23665-5225

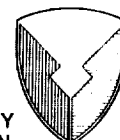

US ARMY  
AVIATION  
SYSTEMS COMMAND  
AVIATION R&T ACTIVITY

2

1

1

1

1

1

1

1

1

1

# INTEGRATED MULTIDISCIPLINARY DESIGN OPTIMIZATION OF ROTORCRAFT

Howard M. Adelman\*  
Interdisciplinary Research Office  
NASA Langley Research Center  
Hampton, Virginia

and

Wayne R. Mantay\*\*  
Aerostructures Directorate  
USAARTA-AVSCOM  
Langley Research Center  
Hampton, Virginia

## Abstract

This paper describes a joint NASA/Army research activity at the Langley Research Center to develop optimization procedures aimed at improving the rotor blade design process by integrating appropriate disciplines and accounting for important interactions among the disciplines. The activity is being guided by a Steering Committee made up of key NASA and Army researchers and managers. The committee, which has been named IRASC (Integrated Rotorcraft Analysis Steering Committee), has defined two principal foci for the activity: a "white paper" which sets forth the goals and plans of the effort; and a rotor design project which will validate the basic constituents, as well as the overall design methodology for multidisciplinary optimization. The paper describes the optimization formulation in terms of the objective function, design variables, and constraints. The analysis aspects are discussed, and an initial attempt at defining the interdisciplinary coupling is summarized. At this writing, some significant progress has been made. Results are given in the paper which represent accomplishments in rotor aerodynamic performance optimization for minimum hover horsepower, rotor dynamic optimization for vibration reduction, rotor structural optimization for minimum weight, and integrated aerodynamic load/dynamics optimization for minimum vibration and weight.

## Introduction

An emerging trend in the analytical design of aircraft is the integration of all appropriate disciplines in the design process (refs. 1 and 2). This means not only including limitations on the design from the various disciplines, but also defining and accounting for interactions so that the disciplines influence design decisions simultaneously rather than sequentially. Because the terms "integrated" and "discipline integration" are frequently used imprecisely, a definition of an integrated disciplinary design process is offered. Such a process is integrated if:

- (1) Information output from any discipline is expeditiously available to all other disciplines as required.
- (2) The effect of a design variable change proposed by one discipline on all other disciplines and the system as a whole is made known promptly.

Adhering to the above definitions is central to the plan to be described in this paper. The integrated approach has the potential to produce a better product as well as a better, more systematic design process. In rotorcraft design (the rotor in particular), the appropriate disciplines include aerodynamics, dynamics, structures, and acoustics. The purpose of this paper is to describe a plan for developing the logic elements for helicopter rotor design optimization which includes the above disciplines in an integrated manner.

Rotorcraft design is an ideal application for integrated multidisciplinary optimization. There are strong interactions among the four disciplines cited previously; indeed, certain design parameters influence all four disciplines. For example, rotor blade tip speed influences dynamics through the inertial and air loadings, structures by the centrifugal loadings, acoustics by local Mach number and air loadings, and aerodynamics through dynamic pressure and Mach number. All of these considerations are accounted for in current design practice. However, the process is usually sequential, not simultaneous, and often involves correcting a design late in the design schedule.

Applications of rigorous and systematic analytical design procedures to rotorcraft have been increasing, especially in the past five years. Procedures have accounted for dynamics (refs. 3-8), aerodynamics (ref. 9), and structures (ref. 10). Generally, these applications have only considered single-discipline requirements, although in reference 5, dynamic and structural requirements were considered together, and in reference 6, dynamics and aeroelastic stability were combined.

In early 1985, several occurrences led to an excellent opportunity at the NASA Langley Research Center to address the multidisciplinary design problem for rotorcraft. The Interdisciplinary Research Office was established and charged with the development of integrated multidisciplinary optimization methods. Nearly concurrently, the Army Aerostructures Directorate at Langley established the goal of improving rotorcraft design methodology by "discipline integration." Close cooperation between the NASA and Army organizations led to initial plans for a comprehensive, integrated analytical design capability. A group of NASA/Army researchers recently formed a committee and began detailed planning for this activity. The committee, designated IRASC (Integrated Rotorcraft Analysis Steering Committee), has now

\*Senior Research Engineer, Member AIAA

\*\*Chief, Aeromechanics Division, Member AHS

completed the bulk of the planning and has formulated the approach described in this paper.

The development of an integrated multidisciplinary design methodology for rotorcraft is a three-phased approach. In phase 1, the disciplines of blade dynamics, blade aerodynamics, and blade structures will be closely coupled, while acoustics and airframe dynamics will be decoupled from the first three but will be accounted for by effective constraints on the other disciplines. In phase 2, acoustics will be integrated with the first three disciplines. Finally, in phase 3, airframe dynamics will be fully integrated with the other four disciplines. In all three phases, systematically validated methods are the principal products of the research.

This paper is primarily concerned with the phase 1 activity; namely, the rigorous mathematical optimization of a helicopter rotor system to minimize a combination of horsepower required at various flight conditions and hub shear transmitted from the rotor to the fuselage. The design will satisfy a set of design requirements including those on blade frequencies, autorotational inertia, aerodynamic performance, and blade structural constraints. Additionally, the design is required to satisfy constraints imposed by response of the fuselage and also those constraints related to acoustics requirements.

### General Approach and Scope

#### Development Strategy

The general approach for the activity is illustrated in figure 1. In phase 1 the blade aerodynamic, dynamics, and structural analyses are coupled and driven by the optimizer. The optimization of the blade aerodynamic geometry as well as the internal structure (spar, leading and trailing edge, ballast, etc.) is performed. The influences of the airframe dynamics and blade acoustics are accounted for in terms of design requirements (constraints) on the blade design. These requirements are described later in the paper. For a check on the efficacy of representing the acoustics requirements indirectly, the "final" design will be input to an acoustics analysis. The acoustics analysis calculates the acoustic response measures and derivatives of these measures with respect to the design variables. This information will be used to determine how well the design was able to satisfy the actual acoustics design requirements.

The phase 2 procedure, wherein acoustics is fully integrated with the blade aerodynamics, dynamics, and structural analysis, is also illustrated in figure 1. The design produced in phase 2 (when converged) will satisfy acoustics goals. Airframe dynamics in phase 2, as in phase 1, is accounted for by effective constraints on the blade dynamics, aerodynamics, and structural behavior. Finally, in phase 3 airframe dynamics is integrated and the result is a fully integrated optimization strategy.

### Sequence of Tasks

Figure 2 depicts the general sequence of tasks that will lead to a fully integrated rotor blade aerodynamic/dynamic/structural optimization procedure which also accounts for acoustic and airframe dynamic influences. The dynamic optimization work is building on the work described in references 5-7. The rotor aerodynamics activity has been separated into two parts. The first is aerodynamic performance optimization which is a continuation of the work described in reference 9. The second is an integration of aerodynamic loads analysis with dynamics - a procedure wherein the local airloads can be adjusted by varying the planform dimensions and twist of the blade to reduce dynamic response. A merger of the rotor performance optimization with the airload/dynamics optimization will yield a fully integrated aerodynamic/dynamic procedure. The rotor structural optimization is a continuation of the work of reference 10. A merger of all the aforementioned procedures, with the acoustic and airframe constraints interfaces, will lead to the fully integrated Phase 1 procedure. The resulting capability will be applied to a rotor test article to validate the procedures.

### Overall Problem Formulation

This section of the paper consists of details of the integrated rotorcraft optimization problem. Included are descriptions of the following: the objective function (the quantity to be minimized for obtaining an optimum design); the design variables (dimensions and other parameters of the design); constraints (a set of behavioral or characteristic limitations required to assure acceptable and safe performance); and definitions of the interactions among the disciplines.

#### Objective Function

The objective function will consist of a combination of the main rotor horsepower at five flight conditions plus a measure of vibratory shear transmitted from the rotor to the hub. Although several multiple objective function techniques are available (ref. 11) one leading candidate is a linear combination whereby

$$F = k_1HP_1 + k_2HP_2 + k_3HP_3 + k_4HP_4 + k_5HP_5 + k_6S \quad (1)$$

where  $F$  is the objective function

$k_1$  through  $k_6$  are weighting factors

$HP_1$  through  $HP_5$  are required horsepower at various flight conditions

$S$  is the vertical hub shear

A candidate set of flight conditions would be:

Flight condition	Description	Velocity (kts)	Load factor
1	Hover	0	1.0
2	Cruise	140	1.0
3	High speed	200	1.0
4	Maneuver	120	3.5
5	Climb	1000 fpm (VROC)	-

### Blade Model and Design Variables

Figure 3 is a depiction of the rotor blade model to be used in the phase 1 optimization activity. Also shown in figure 3 are the design variables which are defined in table 1. The blade model may be tapered in both chord and depth. The depth is linearly tapered from root to tip. The chord is constant from the root to a spanwise location (referred to as the point of taper initiation) and may be linearly tapered thereafter to the tip. Design variables which characterize the overall geometry of the blade include the blade radius, point of taper initiation, taper ratios for chord and depth, the root chord, the blade depth at the root, the flap hinge offset, and the blade maximum twist. Tuning masses located along the blade span are characterized by the mass values and locations. Design variables which characterize the spar box beam cross section include the wall thicknesses at each spanwise segment and the ply thickness at 0° and ±45°. Additional design variables include the number of rotor blades, the rotor angular speed, and the distribution of airfoils.

### Constraints

As previously described, the phase 1 activity is based on integrating the blade aerodynamic, dynamic, and structural analyses within the optimization procedure. The acoustics and airframe dynamics analyses are decoupled from the first three disciplines and their influences are expressed in terms of constraints. Accordingly, the set of constraints is made up of two subsets. The first subset consists of constraints which are evaluated directly from the first three disciplinary analyses and are a measure of the degree of acceptability of the aerodynamic, dynamic, and structural behavior. The second subset represents indirect measures of the satisfaction of constraints on the acoustics behavior and the requirement of avoiding excessive vibratory excitation of the airframe by the rotor.

The constraints are summarized in table 2. The first two constraints are for aerodynamic performance and require that for all flight conditions, main rotor horsepower not exceed available horsepower and that airfoil section stall not occur at any azimuthal location. The next nine constraints address blade dynamics. The first requires that the blade natural frequencies be bounded to avoid approaching any multiples of rotor speed. The next five impose upper limits on the blade vertical and inplane loads, transmitted hub shear, hub pitching, and rolling moments. The next three dynamic constraints are an upper limit on blade response amplitude, a lower limit on blade autorotational inertia, and finally, the aeroelastic stability requirement. The structural

constraints consist of upper limits on box beam stresses, blade static deflection, and blade twist deformation. The acoustic constraints are expressed as an upper bound on the tip Mach number and an upper bound on the blade thickness to limit thickness noise; and an upper bound on the gradient of the lift distribution to limit blade vortex interaction (BVI) and loading noise. The airframe constraints are expressed first as a separation of the fundamental blade inplane natural frequency in the fixed system from the fundamental pitching and rolling frequency of the fuselage to avoid ground resonance; second as a bounding of the blade passage frequency to avoid the proximity to any fuselage frequency.

### Interdisciplinary Coupling

Phase 1 of the effort will utilize several design variables which have historically been significant drivers of disciplinary phenomena. In addition, other variables are being included to provide other unexplored design opportunities. Table 3 shows an attempt to characterize the interactions among the disciplines through the design variables. For example, rotor tip speed has driven past rotor designs based solely on acoustics, performance, or dynamics. This variable also influences blade structural integrity and fixed system response to transmitted loads. This provides the strong interdisciplinary coupling for tip speed shown in table 3. There are variables, such as blade twist, which can strongly influence some disciplines, such as aerodynamics, while not perturbing others (e.g., structures) and other variables such as a hinge offset which, heretofore, have not greatly influenced conventional rotor design.

A significant part of the current effort will not only explore the obvious strong design variable couplings, but will also address those variables which may provide design synergism for multidisciplinary design goals. This may provide a design key for missions which have not been accomplished with today's rotorcraft.

### Implementation Method

#### Organization of System

The overall organization of the system to optimize a blade design for aerodynamics, dynamics, and structural requirements is shown schematically in figure 4. In order to perform the aerodynamic, dynamic, and structural analyses indicated in the blocks in figure 4, it is first necessary to transform or "pre-process" the design variables into quantities needed in the various analyses. For example, the dynamic and structural analyses both need stiffnesses EI and GJ, and laminate properties. The aerodynamic analysis needs lift and drag coefficients for the airfoils used. The above information is obtained by the design variable pre-processors which act as translators of the global design variables into local variables needed in the analyses. The output of each analysis block, in general, serves two purposes. First, response-type output may be transmitted to another analysis block (e.g., airloads from aerodynamics to dynamics); second, information is supplied to the objective function and constraints

block (e.g., stress constraints from the structural analysis). A key part of the procedure is the sensitivity analysis. This block corresponds to the calculation of derivatives of the constraints and objective function with respect to the design variables. The derivatives quantify the effects of each design variable on the design and, thereby, identify the most important design changes to make enroute to the optimum design.

The sensitivity information is passed to the optimizer along with the current values of the design variables, constraints, and objective function. The optimizer uses the information to generate a new set of design variables, and the entire procedure is repeated until a converged design is obtained. For our purposes, a design is converged when all constraints are satisfied and the objective function has reached a value which has not changed for a specified number of cycles.

#### Optimization Algorithm

The basic optimization algorithm to be used in this work is a combination of the general-purpose optimization program CONMIN (ref. 12) and approximate analyses for computing the objective function and constraints. Because the optimization process requires many evaluations of the objective function and constraints before an optimum design is obtained, the process can be very expensive if complete analyses are made for each function evaluation. However, as Miura (ref. 3) points out, the optimization process primarily uses analysis results to move in the direction of the optimum design; therefore, a complete analysis needs to be made only occasionally during the design process and always at the end to check the final design. Thus, various approximation techniques can be used during the optimization to reduce costs. In the present work, the objective function and constraints will be approximated using piecewise linear analyses that consist of linear Taylor series expansions.

#### Analysis Aspects

The analytical tools must provide technical fidelity in phenomena predictions, as well as connectivity between disciplines. The areas of aerodynamics, dynamics, and structures will utilize codes to predict response, as well as sensitivity information. The constraint-providing disciplines of acoustics and airframe dynamics have the analysis task of defining the impact of the design on acoustic energy and fuselage response.

The aerodynamic analysis for rotor performance prediction will include a hover momentum/strip theory code for hover and climb applications (ref. 13). The CAMRAD program (ref. 14) will be used for forward flight and maneuver performance. In order to assure that the latest developments in inflow analyses are available, some modularity will be provided in the inflow modeling based on recent fidelity assessments.

Rotor dynamics will utilize CAMRAD for forced response calculations. Finite element modeling (ref. 15) and the modified Galerkin technique in CAMRAD will form the tools for the dynamic tuning

before the global analysis predicts the final blade loads, response, and rotor stability.

The structural codes involve a combination of beam analysis and laminate analysis. The analysis (e.g., ref. 10) is applied to the blade planform model. The laminate analysis will be applied to one or more cross-section models. The beam model consists of equivalent stiffness and masses from which displacements and forces are computed. The internal blade structure is represented by cross-section models to calculate resultant stresses associated with each beam model segment. The laminate analysis then uses these stresses to determine critical structure margins of safety.

The effectiveness of imposing phase 1 acoustic constraints will be quantified by using the WOPWOP code (ref. 16), with appropriate loading inputs from CAMRAD. Low frequency loading, thickness, and BVI noise will be generated from this analysis.

Airframe dynamics constraints for phases 1 and 2 will result from fixed-system frequency predictions and will neglect hub motion. Phase 3 of the effort will involve finite element modeling and impedance tailoring to effect favorable rotor-body coupling in the design process.

#### Validation Strategy

##### Validation of Procedures

The process of validating the optimization methodology involves substantially more than evaluating the success of the final design. Specifically, the analyses used in optimizing the rotor during Phase 1 will be examined for predictive fidelity and design technique validation. The usefulness of the basic tools involves not only accuracy of analysis, but also a reliable parametric sensitivity capability. Several opportunities are currently available to assess the fidelity of the analyses. For example, rotor performance, dynamics, and acoustics predictions need accurate inflow distributions for various flight conditions. Recent experimental efforts (e.g., ref. 17) and code validations (ref. 18) are helping to provide confidence in the available inflow models. Rotor geometric design variable sensitivity (e.g., effect of taper on performance), which was reasonably well-known for past rotor designs, is being re-examined in light of recent correlation anomalies for high-speed flight. Acoustic source mechanisms and modeling validity are also being examined (ref. 19), especially for parametric sensitivity of the acoustic energy to rotor state. Structural coupling mechanics are being exploited in new rotor designs to assess the structural tailoring benefits while satisfying structural integrity requirements (ref. 20).

Proof of the fidelity of design techniques is crucial to the overall design optimization effort. For example, aerodynamics and dynamics interact so strongly in rotor design that basic aeroelastic tailoring efforts must be validated. Such a validation effort is being undertaken at Langley, as well as other research centers (ref. 21). Also, because rotor speed is a strong driver for aeroelastic response, a program to assess variable RPM designs is underway at Langley. The objective of

this effort is to define the benefits and limitations of an aerodynamically and dynamically designed multi-speed rotor. In addition to design techniques which capitalize on the strong effects of certain design variables, small variances in other blade characteristics may impede the practical operation of even conventional designs. Hence, the ability to accurately predict even these secondary phenomena is important for the design effort. For example, track-and-balance sensitivity experiments and studies are being undertaken which can lead to practical design capability to eliminate blade-to-blade variability effects.

#### Overall Design Validation

For the overall phase 1 validation effort, the Langley team is defining a rotor task which requires maneuverability, speed, and efficiency (see table 4). Specifically, the rotor mission must be accomplished with minimum power and vibration while satisfying predefined acoustic, stability, and fuselage dynamics requirements. This validation activity is, in effect, a design project which will produce a rotor test article.

The assessment of the phase 1 design methods will involve model rotor hover and wind tunnel tests. The models (a baseline and an advanced design) will be aerodynamically and dynamically scaled. Provisions for varying key design parameters are necessary to complete the validation process. In other words, the tests need to quantify not only the minima, but the gradients. The testing possibilities include a series of 1/5-scale model rotors, mounted on a variable drive system and tested in hover and simulated forward flight in a tunnel which can eliminate many testing "excuses" such as inappropriate Reynolds, Mach, and Froude Numbers. The Langley TDT is the candidate facility for the major segments of the validation process.

#### Results Obtained to Date

Progress has been made in the areas of aerodynamic performance optimization, optimum placement of tuning masses for vibration reduction, structural optimization, and integrated aerodynamic load/dynamic optimization. Selected results from these activities are highlighted in this portion of the paper.

#### Results - Aerodynamic Performance Optimization

A Mathematical Programming technique (ref. 9) has been developed to minimize the hover horsepower for a helicopter with a specified design gross weight operating at a specified altitude and temperature (fig. 5). A conventional design approach is usually a two-step iterative method. The first step is design for optimum hover performance by varying taper ratio, point of taper initiation, and twist until the rotor blade configuration with the lowest hover horsepower is obtained. In the second step, this best hover design is modified by changing the root chord to meet forward flight and maneuverability requirements. The Mathematical Programming approach used the same performance analyses as the conventional approach, but coupled a general-purpose optimiza-

tion program to the analyses. The conventional and Mathematical Programming approaches have been used to define the blade configuration which provides the lowest hover horsepower and satisfies forward flight and maneuverability requirements. Figure 5 summarizes results for the final design variable values and the main rotor horsepower required for hover from each approach. The Mathematical Programming approach produced a design with more twist, a point of taper initiation further outboard, and a smaller blade root chord than the conventional approach. The Mathematical Programming design required 25 less hover horsepower than the conventional design. Most significantly, the Mathematical Programming approach obtained results more than ten times faster than the conventional approach.

#### Results - Optimum Locations of Vibration Tuning Masses

The objective of this work (described in ref. 22) is to develop a method for optimally locating, as well as sizing, tuning masses to reduce vibration using formal mathematical optimization techniques. The design goal is to find the best combination of tuning masses and their locations to minimize blade root vertical shear without a large mass penalty. The method is to formulate and solve an optimization problem in which the tuning masses and their locations are design variables that minimize a combination of vertical shear and the added mass, with constraints on frequencies to avoid resonance. Figure 6 shows an arbitrary number of masses placed along the blade span. The optimization strategy reduces the oscillatory shear as a function of time during a revolution of the blade.

Results have been obtained wherein the above strategy was applied to a rotor blade considering multiple blade mode/multiple harmonic airloads. The example problem is a beam representation of an articulated rotor blade. The beam is 193 inches long with a hinged end condition and is modeled by 10 finite elements of equal length. The model contains both structural mass and lumped (non-structural) masses. Three lumped masses are to be placed along the length of the beam. The strategy was applied to a test case of two modes responding to three harmonics of airload. Figure 7 shows for the initial and final designs, the shear  $s$  plotted as a function of the time and azimuth for one complete revolution of the blade. The peaks on the initial curve have been reduced dramatically. For example, the maximum peak oscillatory shear for the initial design is 78.00 lbf, and for the final design, the maximum peak is 0.60 lbf.

#### Results - Rotor Structural Optimization

A blade structural optimization procedure applicable to metal and composite blades has been developed in which the objective function is blade mass with constraints on frequencies, stresses in the spars and in the skin, twist deformation, and autorotational inertia. The design variables (figure 8) are the total spar thickness and for the composite blade the percentage of  $\pm 45^\circ$  plies (the remaining plies are assumed to be at  $0^\circ$ ). This procedure and additional applications of the method are given in reference 10.

This section describes two example rotor blade designs which were developed using the structural design methodology. Both designs are based on the UH-60 Black Hawk blade. The first design is for a titanium single spar cross section. The second case has a graphite/epoxy spar in a single spar cross-section configuration. The composite spar design is compared to the metal spar design to explore potential weight savings obtained from use of the design methodology in conjunction with composite materials.

Titanium cross section.- For the titanium spar blade, the cross-section model was based on the UH-60 rotor blade with identical skin, core, trailing edge tab, leading edge weight, and spar coordinates. Only the spar thickness was used as a design variable. The beam model representation of the blade used a rectangular planform similar to the UH-60 planform, but without any tip sweep. A maximum elastic torsional deformation of  $3.1^\circ$  is based on an effective aerodynamic performance constraint (ref. 10). The structural constraint requires that the calculated stresses do not exceed the allowable material strength based on the Tsai-Hill failure criterion. The autorotational capability is assumed to be the same for this design as it is for the UH-60. Autorotation is satisfied by requiring the mass moment of inertia to be identical to that of the UH-60 rotor system which is 19000 in-lbs-s per blade. Before a structural comparison to the UH-60 blade can be made, the design had to be dynamically tuned. The modes considered in this design were first elastic flapwise and edgewise bending, first torsion, and second and third flapwise bending. The frequencies of these modes were required to be removed from integer multiples of the forcing frequency by 0.2 per rev.

As shown in figure 8, the minimum spar thickness needed to satisfy all the constraints was 0.130 inch which corresponds to a blade weight of 207 pounds. The actual UH-60 titanium spar is 0.135 inch thick, producing a 210 pound blade. The titanium spar design is only 3 pounds different from the actual UH-60 blade, demonstrating that the mechanics of the design methodology can produce blade designs similar to conventional design processes.

Composite cross section.- A second design was developed using a single T300-5208 graphite/epoxy D-spar. The blade models and associated design assumptions used in the composite design were the same as those used for the metal spar except for the spar material. Here, thickness and ply orientation of the composite spar were used as design variables. The plies of the spar were assumed to consist only of  $0^\circ$  and  $\pm 45^\circ$  angles symmetrically built up. Thus, the ply orientation design variable was the percentage of  $\pm 45^\circ$  plies in the laminate. The remaining plies of the laminate are understood to be oriented at  $0^\circ$ . Constraints on twist deformation, material strength, mass moment of inertia, and dynamic tuning were the same as those used for the metal design.

Results shown in figure 8 show that the composite design satisfied the required constraints. Further, the minimum weight design had a 0.105 inch thick spar with 20 percent of the plies oriented at  $\pm 45^\circ$  degrees which resulted in blade weight savings of 21.5 percent. These results

demonstrate that this design methodology, used in conjunction with composite materials, can result in significant weight savings.

### Results - Integrated Aerodynamic Load/Dynamic Optimization

In reference 23, an integrated aerodynamic load/dynamic optimization procedure was developed. The procedure minimized blade weight and  $4/\text{rev}$  vertical hub shear for a rotor in forward flight. The coupling of aerodynamics and dynamics was accomplished by the inclusion of air load calculations inside the optimization loop wherein the air loads varied with design variables. The design model used for this procedure is the same as that in figure 3. The design variables include the stiffnesses  $EI$  for spanwise and chordwise bending, the torsional  $GJ$ , the taper ratio, the root chord, radius of gyration, and nonstructural masses at each spanwise location. The constraints include upper and lower bounds on the first four frequencies, a lower bound on autorotational inertia, and an upper bound on centrifugal stress. Both single and multiple objective function formulations were used and compared. In the single objective function formulations, blade weight and  $4/\text{rev}$  shear were each individually minimized. For the multiple objective function formulation, a combination of the weight and shear was minimized by use of the Global Criteria Approach (ref. 11).

A flow chart showing the logic of the optimization procedure is shown in figure 9. The process is initiated by evaluating the preassigned parameters (those which are constant during the optimization). The next step is to initialize the design variables and perform the blade structural analysis to calculate the blade properties, the centrifugal stress and the autorotational inertia. The aerodynamic and dynamic response analyses are performed next using CAMRAD. CAMRAD is used to calculate the section loads from the airfoil two-dimensional aerodynamic characteristics. Lifting line theory is used with corrections for yawed and three-dimensional flow effects. The blade is trimmed at each pass through the optimization loop using the wind tunnel trim option. The dynamic analysis in CAMRAD includes calculations of the frequencies and mode shapes (using a modified Galerkin technique) and the calculation of the  $4/\text{rev}$  vertical shear at the hub. A sensitivity analysis calculates derivatives of the objective function and the constraints with respect to the design variables. Analytical derivatives are used for the weight, autorotational inertia and centrifugal stress. Forward finite differences are used for the derivatives of the hub shear and the frequencies. Once the sensitivity analysis is completed, the optimizer is called to update the design variables.

The above procedure has been applied to a model of the Growth Black Hawk rotor blade (see reference 23 for details of this model). The baseline (analytical) model is linearly tapered from root to tip with a taper ratio of 3.0, has eight structural nodes, 14 aerodynamics segments, and a single airfoil for all segments. The aircraft is in forward flight with an advance ratio of 0.3. Figure 10 presents comparisons of optimum weight and vertical shear from the three formulations. Figure 10a compares the blade weight and



figure 10b compares the 4/rev vertical shear. As shown in the figure, the Global Criteria Approach provides the lightest blade structure with a significant hub shear reduction. This is contrary to the intuitive belief that the use of a multiple objective formulation should yield solutions lying between those of the single objective formulations. In other words, the blade weight obtained by simultaneously minimizing weight and hub shear might be expected to be higher than that obtained from weight minimization and the hub shear obtained should be higher than that obtained from hub shear minimization. However, this is only true if the objective functions are monotonically increasing functions of the design variables. This is not true in the present case since, for example, the blade weight can decrease with an increase in taper ratio and the hub shear is a very complicated and nonmonotonic function of the design variables.

It was of interest to determine the extent to which the optimization process reduced the oscillatory airloads. To this end, distributions of vertical oscillatory airloads before and after optimization are compared. Figure 11 shows azimuthal distributions of vertical airloads for the initial (reference) design and for the three optimum designs at a radial station of 0.75 of the blade span. All three optimization results indicate a significant reduction in oscillatory airload amplitudes. The largest reduction occurred for the third formulation. As pointed out in reference 23, this is a significant finding and indicates that the optimization process is able to adjust the vibration levels downward not only by frequency placement and modal shaping but also by adjusting airload distributions in a favorable manner.

#### Concluding Remarks

This paper has described a joint activity involving NASA and Army researchers at the NASA Langley Research Center to develop optimization procedures aimed at improving the rotor blade design process by integrating appropriate disciplines and accounting for all of the important interactions among the disciplines. The disciplines involved include rotor aerodynamics, rotor dynamics, rotor structures, airframe dynamics, and acoustics. The work is focused on combining the five key disciplines listed above in an optimization procedure capable of designing a rotor system to satisfy multidisciplinary design requirements.

Fundamental to the plan is a three-phased approach. In phase 1, the disciplines of blade dynamics, blade aerodynamics, and blade structure will be closely coupled, while acoustics and airframe dynamics will be decoupled and be accounted for as effective constraints on the design for the first three disciplines. In phase 2, acoustics is to be integrated with the first three disciplines. Finally, in phase 3, airframe dynamics will be fully integrated with the other four disciplines.

This paper dealt primarily with the phase 1 approach. The paper included: the optimization formulation, design variables, constraints, and objective function, as well as discipline interactions, analysis methods, and methods for validating the procedure. The paper described how the

acoustics and airframe dynamics behaviors are incorporated as constraints into the design procedure. For example, acoustics imposes a local Mach number constraint on the blade velocity and angle of attack; and airframe dynamics imposes constraints on the rotor blade natural frequencies to avoid ground resonance through coalescence of blade and airframe frequencies. The plan for validating the components of the design process was described and the strategy for overall validation of the design methodology was defined. These validations are critical to the success of the activity and are viewed as the primary products of the work. Finally, some representative results from work performed to date are shown. These include aerodynamic optimization results for performance, optimal placement of tuning mass for reduction of blade shear forces, blade structural optimization for weight minimization subject to strength constraints, and integrated airload/dynamic optimization results for vibration reduction.

The results of the individual optimization procedures demonstrate the potential of optimization in design of future rotorcraft, both from the standpoint of efficiency of the process as well as potentially improved products. The results of the integrated airload/dynamic optimization procedure demonstrates that there are significant benefits awaiting analytical designers who pursue interdisciplinary design approaches.

#### References

1. Ashley, H.: On Making Things the Best - Aeronautical Use of Optimization. AIAA Journal of Aircraft, vol. 19, no. 1, 1982.
2. Sobieszczanski-Sobieski, J.: Structural Optimization Challenges and Opportunities. Presented at International Conference on Modern Vehicle Design Analysis, London, England, June 1983.
3. Miura, H.: Application of Numerical Optimization Methods to Helicopter Design Problems: A Survey. NASA TM-86010, October 1984.
4. Bennett, R. L.: Application of Optimization Methods to Rotor Design Problems. Vertica, vol. 7, no. 3, 1983, pp. 201-208.
5. Peters, D. A.; Rossow, M. P.; Korn, A.; and Ko, T.: Design of Helicopter Rotor Blades for Optimum Dynamic Characteristics. Computers and Mathematics With Applications, vol. 12A, no. 1, 1986, pp. 85-109.
6. Friedmann, P.: Application of Modern Structural Optimization to Vibration Reduction in Rotorcraft. Vertica, vol. 9, no. 4, 1986, pp. 363-376.
7. Chattopadhyay, Aditi; and Walsh, Joanne L.: Minimum Weight Design of Rotorcraft Blades With Multiple Frequency and Stress Constraints. Proceedings of the AIAA/ASME/ASCE/ARS 29th Structures, Structural Dynamics and Materials Conference, Williamsburg, VA, April 18-20, 1988. AIAA Paper No. 88-2337-CP. Also available as NASA TM-100569, March 1988.

8. Davis, M. W.: Optimization of Helicopter Rotor Blade Design for Minimum Vibration. NASA CP-2327, Part 2, September 1984, pp. 609-625.
9. Walsh, J. L.; Bingham, G. J.; and Riley, M. F.: Optimization Methods Applied to the Aerodynamic Design of Helicopter Rotor Blades. Journal of American Helicopter Society, October 1987, pp. 39-44.
10. Nixon, M. W.: Preliminary Structural Design of Composite Main Rotor Blades for Minimum Weight. NASA TP-2730, July 1987.
11. Rao, S. S.: Multiobjective Optimization in Structural Design with Uncertain Parameters and Stochastic Processes. AIAA Journal, Vol. 22, No. 11, November 1984.
12. Vanderplaats, G. N.: CONMIN - A Fortran Program for Constrained Function Minimization. User's Manual. NASA TMX-62282. August 1973.
13. Gessow, Alfred; and Myers, Garry C., Jr.: Aerodynamics of the Helicopters. Frederick Unger Publishing Company, New York, 1952.
14. Johnson, Wayne: A Comprehensive Analytical Model of Rotorcraft Aerodynamics and Dynamics. NASA TM 81182, 1980.
15. Whetstone, W. D.: EISI-EAL Engineering Analysis Language Reference Manual. Engineering Information Systems, Inc., San Jose, CA, 1983.
16. Brentner, K. S.: Prediction of Helicopter Rotor Discrete Frequency Noise - A Computer Program Incorporating Realistic Blade Motions and Advanced Acoustic Formulation. NASA TM-87721, October 1986.
17. Elliott, J. W.; Althoff, S. L.; and Sailey, R. H.: Inflow Measurement Made with a Laser Velocimeter on a Helicopter Model in Forward Flight. NASA TM-100541, April 1988.
18. Berry, J. D.; Hoad, D. R.; Elliott, J. W.; and Althoff, S. L.: Helicopter Rotor Induced Velocities Theory and Experiment. American Helicopter Society Specialists Meeting on Aerodynamics and Aeroacoustics, Forth Worth, TX, February 1987.
19. Caradonna, F. X.; Lautenschlager, J. L.; and Silva, M. J.: An Experimental Study of Rotor-Vortex Interactions. Preprint from AIAA 26th Aerospace Sciences Meeting, January 1988.
20. Lake, R. C.; and Nixon, M. W.: Results From a Preliminary Investigation of Finite-Element Modeling in Analysis of Composite Rotor Blades. Second International Conference on Rotorcraft Basic Research, February 1988.
21. Weller, William H.; and Davis, Mark W.: Experimental Verification of Helicopter Blade Designs Optimized for Minimum Vibration. Proceedings of the 44th Annual Forum of the American Helicopter Society, Washington, DC, June 1988.
22. Pritchard, J. I.; and Adelman, H. M.: Optimal Placement of Tuning Masses for Vibration Reduction in Helicopter Rotor Blades. Presented at the Second International Conference on Rotorcraft Basic Research, College Park, Md., February 1988.
23. Chattopadhyay, Aditi; Walsh, Joanne L.; and Riley, Michael F.: Integrated Aerodynamic/Dynamic Optimization of Helicopter Rotor Blades. NASA TM-101553, Feb. 1989.

TABLE 1 SUMMARY OF DESIGN VARIABLES

Description	Symbol
Tuning mass at location $i$	$m_i$
Spanwise location of $i$ -th mass	$x_i$
Wing box dimensions	$t_1, t_2, t_3$
Ply thicknesses	$t_{45}, t_0$
Depth of blade at root	$h_r$
Ratio of blade depths at tip and root	$\lambda_h = h_r/h_t$
Maximum pre-twist of blade	$\tau_{max}$
Percent blade span where taper begins	$r$
Blade root chord	$c_r$
Airfoil distribution	-
Hinge offset	$e$
Blade angular velocity	$\Omega$
Number of blades on rotor	$N$
Blade radius	$R$
Ratio of root chord to tip chord	$\lambda_c = c_r/c_t$

TABLE 2 SUMMARY OF CONSTRAINTS

Constraint Description	Form of Constraint	Comments
Main rotor horsepower	$HP_i < HP_{avail}$ for i-th condition	For 5 flight conditions
Airfoil section stall	$C_D < C_{Dmax}$	Enforced at 12 azimuthal locations
Blade frequencies	$f_{il} < f_i < f_{iu}$	
Blade vertical load	$V_{ik} < V_{max}$	
Blade inplane load	$H_{ik} < H_{max}$	
Transmitted in-plane hub shears	$X_k < X_{max}$	
Hub pitching moment	$Y_k < Y_{max}$	
Hub rolling moment	$P_k < P_{max}$	
Blade response amp.	$R_k < R_{max}$	
Autorotational inertia	$Q_k < Q_{max}$	
Aeroelastic stability	$\sum m_i r_i^2 > \alpha$	
Wing box stresses	$Re(\lambda) < -\epsilon$	
Wing box stresses	$R < 1$	R = Tsai-Hill criterion
Blade tip deflection	$w < w_{max}$	
Blade twist	$\theta < \theta_{max}$	
Blade tip Mach no.	$M < M_{max}$	Limits thickness noise
Blade thickness	$h < h_{max}$	
Blade lift distribution	$dC_l/dx < S_{max}$	Limits BVI & loading noise
Ground resonance Rotor/Airframe frequency coupling	$ \Omega - \omega_{L1}  < \omega_{af}$ $f_1 < \Omega < f_u$	Effective airframe constraints

TABLE 3 INTERACTIONS AMONG DISCIPLINES

Variable	Acoustics	Aerodyn. (Perf & Loads)	Dynamics	Structures	Fuselage Dynamics
Airfoil Dist.	S	S	W	W	W
Planform	S	S	S	S	S/W
Twist	W	S	S	W	W
Tip speed	S	S	S	S	S
Blade number	S	W	S	W	S
Stiffness	W	S	S	S	S/W
Mass dist.	W	W	S	S	S/W
Hinge offset	W	W	S/W	W	S/W

S = Strong interaction  
W = Weak interaction

TABLE 4 CANDIDATE TASK AND MISSION FOR PHASE 1 DESIGN ACTIVITY

Description	Specification
Condition	4000 ft 95°
Aircraft gross weight	16875 lb
Installed power limit	3400 HP
V <sub>cruise</sub>	140 kts
V <sub>max</sub>	200 kts
g's at 120 kts	3.5
Vertical rate of climb	1000 fpm
Airframe structure	UH-60B

Other constraints and guidelines are specified in table 2.

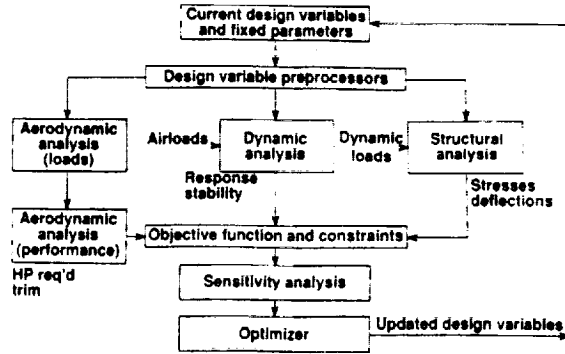

Fig. 4 Integrated aerodynamic-dynamic-structural optimization of rotor blades.

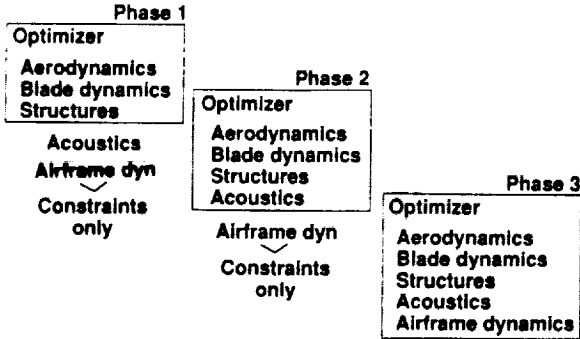

Fig. 1 Phased approach to development of integrated rotorcraft optimization procedures.

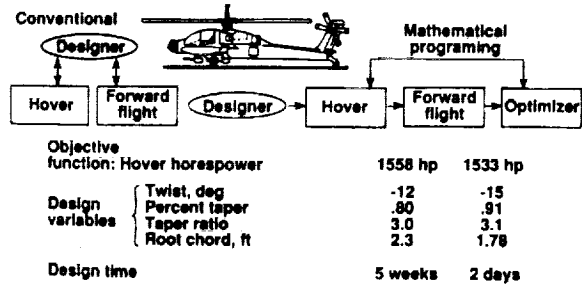

Fig. 5 Results of aerodynamic performance optimization.

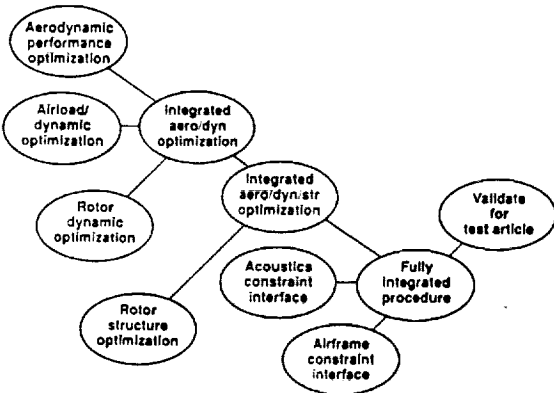

Fig. 2 Integrated rotorcraft optimization development plan.

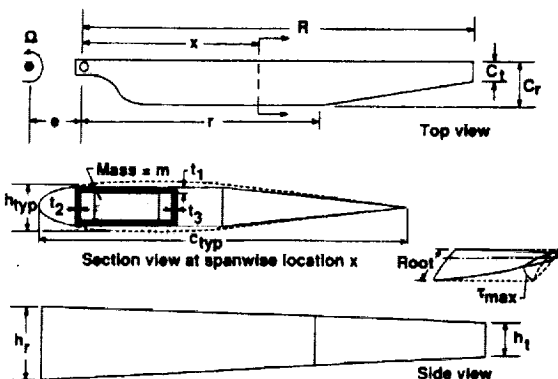

Fig. 3 Blade model and design variables.

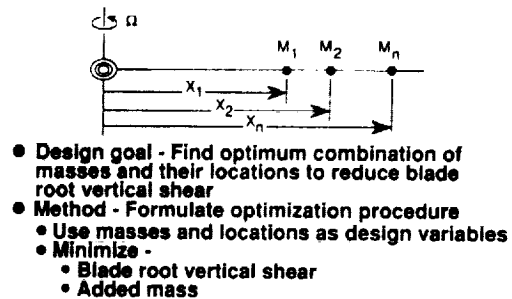

Fig. 6 Selection of optimum locations of tuning masses for vibration reduction.

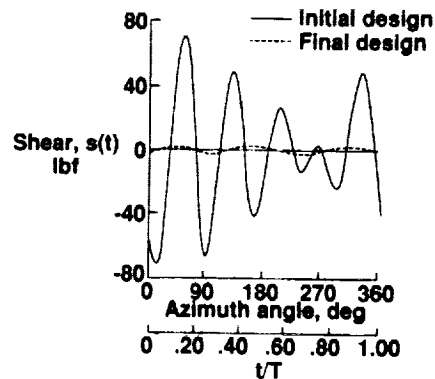

Fig. 7 Time history of vertical root shear minimized for 2 modes/3 harmonics.

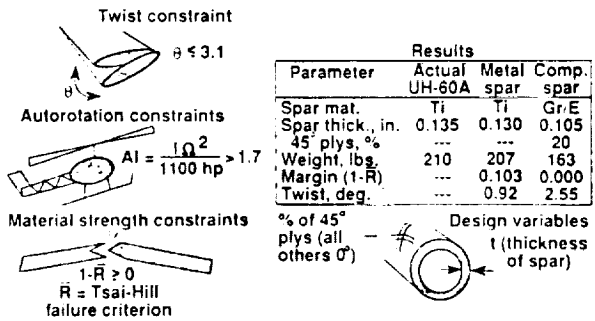
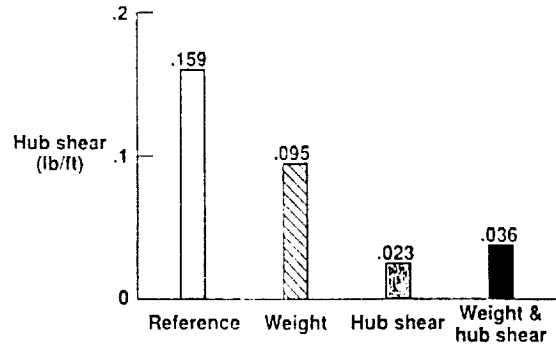

Fig. 8 Structural optimization for minimum weight rotor blades.



(b) Optimum 4/rev hub shear from various formulations.

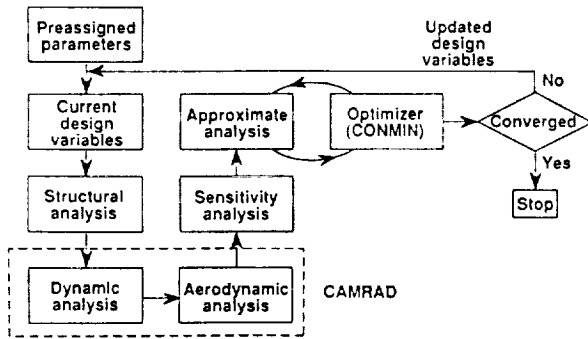

Fig. 9 Flow chart for integrated aerodynamic load/dynamic optimization procedure.

Fig. 10 Concluded.

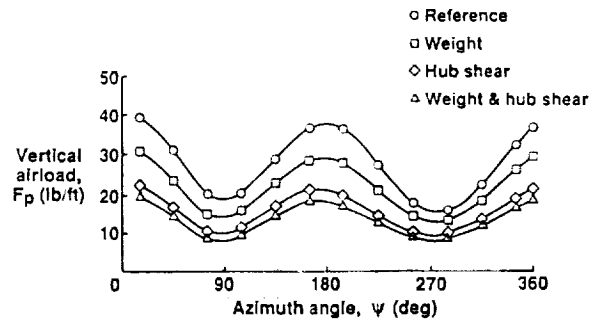
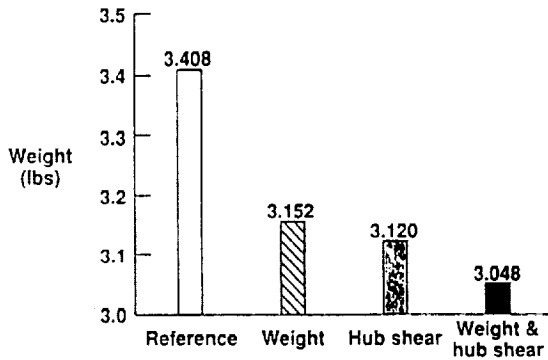

Fig. 11 Azimuthal distributions of vertical airload, 75% radius,  $\mu = 0.3$ .



(a) Optimum weight from various formulations.

Fig. 10 Results from integrated aerodynamic load/dynamic optimization procedure.



# Report Documentation Page

1. Report No. NASA TM-101642 AVSCOM TM- 89-B-008		2. Government Accession No.		3. Recipient's Catalog No.	
4. Title and Subtitle Integrated Multidisciplinary Design Optimization of Rotorcraft				5. Report Date July 1989	
				6. Performing Organization Code	
7. Author(s) Howard M. Adelman Wayne R. Mantay				8. Performing Organization Report No.	
				10. Work Unit No. 505-63-51-10	
9. Performing Organization Name and Address NASA Langley Research Center and Aerostructures Directorate, USAARTA-AVSCOM Hampton, VA 23665-5225				11. Contract or Grant No.	
				13. Type of Report and Period Covered Technical Memorandum	
12. Sponsoring Agency Name and Address National Aeronautics and Space Administration Washington DC 20546-0001 and US Army Aviation Systems Command St. Louis, MO 63120-1798				14. Sponsoring Agency Code	
				15. Supplementary Notes Paper presented at AIAA/AHS/ASEE 1989 Aircraft Design and Operations Meeting Seattle Washington July 31-Aug. 2, 1989 Howard M. Adelman, NASA Langley Research Center, and Wayne R. Mantay, Aerostructures Directorate, USAARTA-AVSCOM, NASA Langley Research Center	
16. Abstract This paper describes a joint NASA/Army research activity at the Langley Research Center to develop optimization procedures aimed at improving the rotor blade design process by integrating appropriate disciplines and accounting for important interactions among the disciplines. The activity is being guided by a Steering Committee made up of key NASA and Army researchers and managers. The committee, which has been named IRASC (Integrated Rotorcraft Analysis Steering Committee), has defined two principal foci for the activity: a "white paper" which sets forth the goals and plans of the effort; and a rotor design project which will validate the basic constituents, as well as the overall design methodology for multidisciplinary optimization. The paper describes the optimization formulation in terms of the objective function, design variables, and constraints. The analysis aspects are discussed, and an initial attempt at defining the interdisciplinary coupling is summarized. At this writing, some significant progress has been made. Results are given in the paper which represent accomplishments in rotor aerodynamic performance optimization for minimum hover horsepower, rotor dynamic optimization for vibration reduction, rotor structural optimization for minimum weight, and integrated aerodynamic load/dynamics optimization for minimum vibration and weight.					
17. Key Words (Suggested by Author(s)) Optimization Helicopters Rotor blades			18. Distribution Statement Unclassified-Unlimited  Subject Category 05		
19. Security Classif. (of this report) Unclassified		20. Security Classif. (of this page) Unclassified		21. No. of pages 12	22. Price A03