

5/10-92

5m

N90-12469

343220
16

The BATSE Experiment on the Gamma Ray Observatory:
Solar Flare Hard X ray and Gamma-Ray Capabilities

G.J. Fishman, C.A. Meegan, R.B. Wilson, T.A. Parnell
(NASA/MSFC); W.S. Paciesas, G.N. Pendleton (UAH);
H.S. Hudson, J.L. Matteson, L.E. Peterson (UCSD);
T.L. Cline, B.J. Teegarden, B.E. Schaefer (NASA/GSFC)

ABSTRACT

The Burst and Transient Source Experiment (BATSE) for the Gamma Ray Observatory (GRO) consists of eight detector modules that provide full-sky coverage for gamma-ray bursts and other transient phenomena such as solar flares. Each detector module has a thin, large-area scintillation detector (2025 cm²) for high time-resolution studies, and a thicker spectroscopy detector (125 cm²) to extend the energy range and provide better spectral resolution. The total energy range of the system is 15 keV to 100 MeV. These 16 detectors and the associated onboard data system should provide unprecedented capabilities for observing rapid spectral changes and gamma-ray lines from solar flares. The presence of a solar flare can be detected in real-time by BATSE; a trigger signal is sent to two other experiments on the GRO. The launch of the GRO is scheduled for June 1990, so that BATSE can be an important component of the MAX '91 campaign.

1. INTRODUCTION

The Gamma Ray Observatory (GRO), the second of NASA's Great Observatories, is scheduled for launch in June, 1990. The four experiments of the GRO are at least an order of magnitude more sensitive than their predecessors, and it is expected that the GRO will bring the field of gamma-ray astronomy into a mature observational phase. The four experiments have different yet complementary goals, with overlapping energy ranges and distinct observational techniques.

Although the primary scientific objective of BATSE is the study of gamma-ray bursts and other transient phenomena, it has design features which will enable it to make significant contributions to solar physics. For strong solar flares, its large effective area will permit hard x-ray and gamma-ray observations with a sensitivity greater than both the HXRBS and the GRS experiments on SMM. These observations will be especially important in the upcoming solar maximum when, following the end of the SMM, the U.S. has no other long-term high-energy solar monitoring

capability. This paper is derived from several papers that were recently presented at the GRO Science Workshop held at Goddard Space Flight Center in April 1989 (Fishman et al. 1989a,b; Paciasas et al. 1989a; Pendleton et al. 1989). It concentrates on a description of the BATSE instrumentation and data analysis system--both of which would be of interest to potential users of BATSE for solar investigations. The papers of the GRO Workshop describe in more detail the scientific objectives and capabilities of BATSE and contain more information on the instrument and data analysis system being developed. Copies of those papers are available upon request.

2. EXPERIMENT CONFIGURATION

BATSE consists of eight uncollimated detector modules arranged on the corners of the Gamma Ray Observatory (GRO) to provide the maximum unobstructed view of the celestial sphere. Each detector module contains a large-area detector (LAD), optimized for sensitivity and directional response, and a spectroscopy detector (SD) optimized for broad energy coverage and energy resolution.

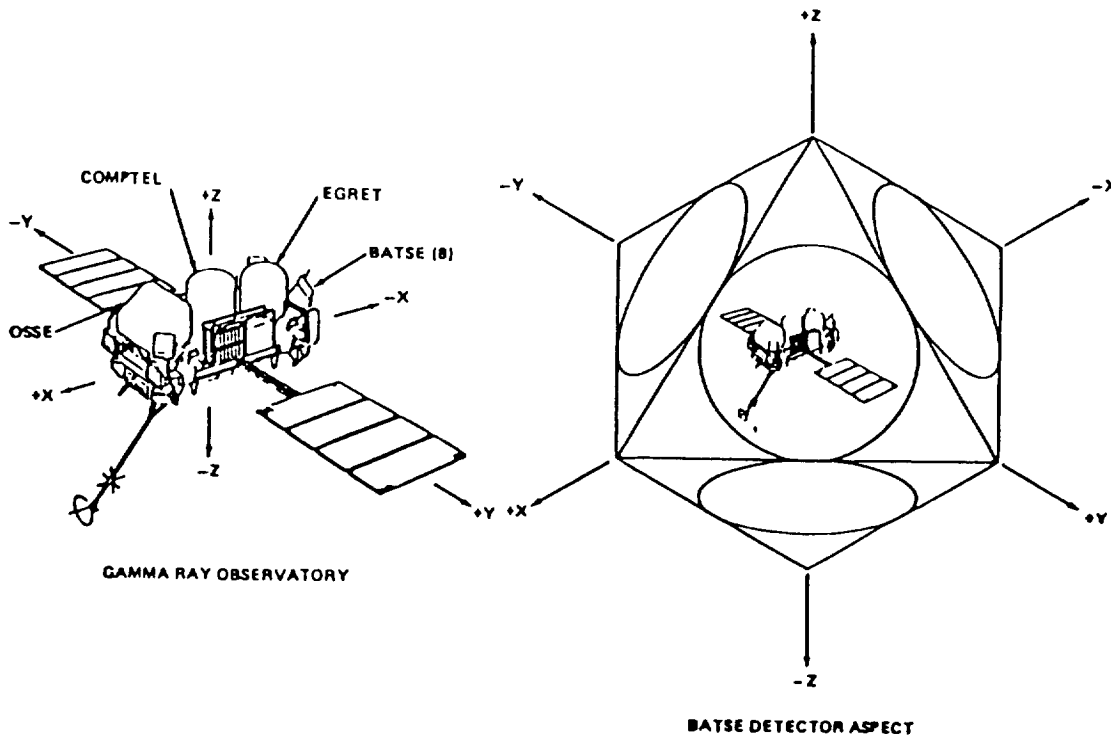

Figure 1. Illustration showing the co-alignment of the principal axes of the Gamma Ray Observatory with the octahedron geometry of the BATSE detectors.

The eight planes of the LADs are parallel to the eight faces of a regular octahedron, thus providing nearly uniform sky coverage. As shown in Figure 1, the three primary axes of the octahedron are parallel to the three principal axes of the spacecraft. Since the faces of a regular octahedron comprise four pairs of intersecting planes, every detected burst will be viewed by four detectors. Similarly, four detectors will always view the Sun during the daytime portions of each orbit.

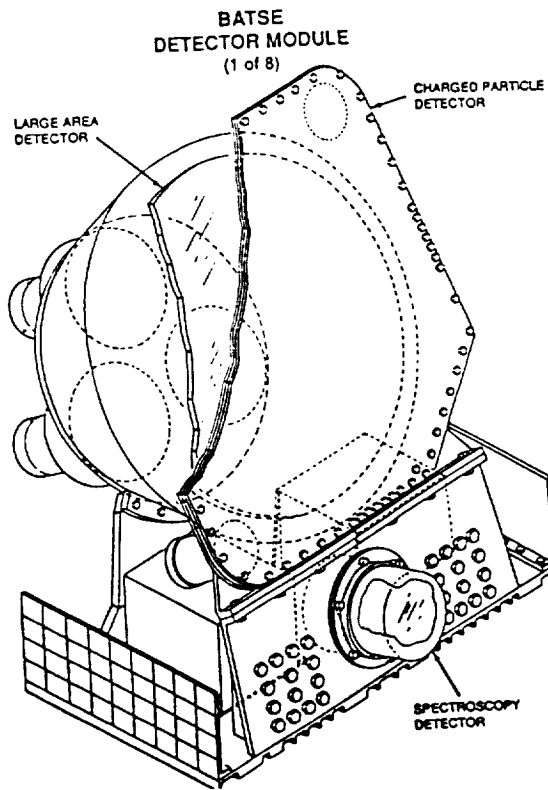

Figure 2. Pictorial representation of a BATSE detector module.

2.1. Large-Area Detector (LAD)

As shown schematically in Figure 2, the LAD contains a NaI(Tl) crystal 50.8 cm (20 in.) in diameter and 1.27 cm (0.5 in.) thick. The large diameter-to-thickness ratio of the scintillation crystal produces a detector angular response similar to that of a cosine function at low energies where the crystal is opaque to incident radiation. At energies above about 300 keV, the angular response is flatter than a cosine. The LADs are uncollimated in the forward hemisphere and passively shielded in the rear hemisphere.

Scintillation light from the detector crystal is viewed by three 12.7 cm (5 in.) photomultiplier tubes (PMTs). The signals from the three tubes are summed at the detector. A large light-integrating housing is used to collect the scintillation light in a relatively uniform manner (Figure 2). The housing is lined with passive lead/tin shielding and is coated with a barium sulphate-based white reflector. The passive shielding is effective up to energies of about 200 keV. The front of the LAD is covered by plastic scintillator (BC400, 0.63 cm thick) that rejects charged-particle-induced events in the LAD. Detailed performance characteristics of the LAD's are given by Paciesas et al. (1989b).

2.2. Spectroscopy Detector (SD)

The SD is an uncollimated NaI(Tl) scintillation detector 12.7 cm in diameter by 7.62 cm thick (5 in. x 3 in.). A single 12.7 cm diameter PMT is directly coupled to the scintillation detector window. The housing of the PMT has a passive lead/tin shield similar to that of the LADs. The crystal housing has a 3 in. diameter beryllium window, in order to provide high efficiency at energies as low as 15 keV. The axis of symmetry of a SD is offset by 19 degrees from the LAD axis, for mechanical reasons. The angular response of the SD is more nearly isotropic, so that alignment of the axes is not required.

Properties of the BATSE detectors are summarized in Table 1. The sensitive area and resolution of the detectors are shown in Figures 3 and 4, respectively.

	BATSE DETECTORS	
	LARGE AREA	SPECTROSCOPY
Material:	NaI(Tl)	NaI(Tl)
Frontal Area:	2,025 cm ²	127 cm ²
Thickness:	1.27 cm	7.62 cm
Energy Range:	30 - 1900 keV	15 keV - 110 MeV*
Energy Resol.:	27% @ 88 keV typ.	7.2% @ 662 keV typ.
		*Detector gain dependent

Table 1. BATSE Detector summary chart.

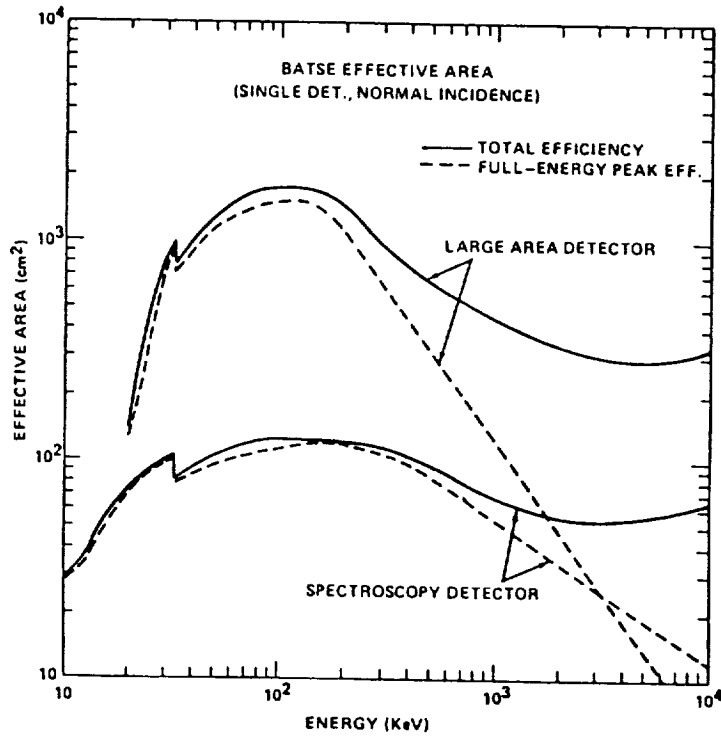

Figure 3. Effective areas of the BATSE LAD and SD as functions of energy.

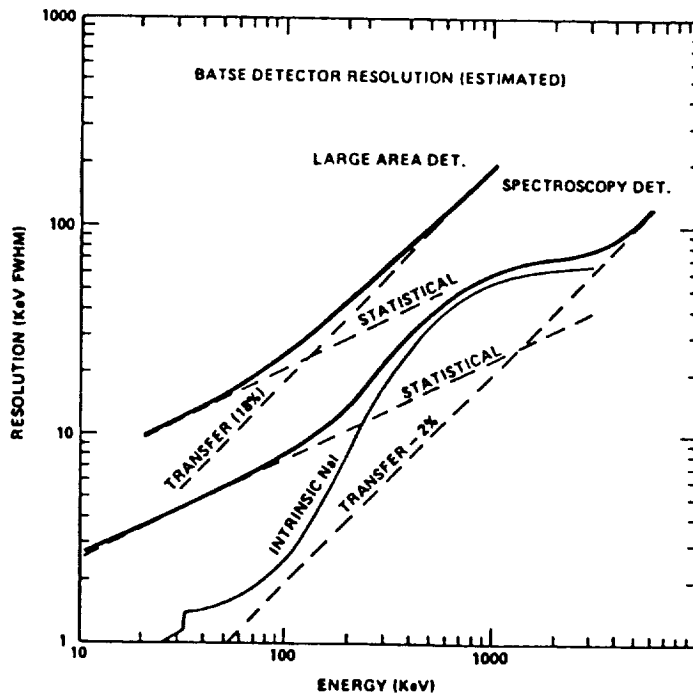

Figure 4. Energy resolutions of the BATSE LAD and SD as functions of energy.

2.3. Analog Electronics

Scintillation pulses from the detectors are processed by a gated baseline restoration circuit which minimizes the spectral distortion that usually accompanies high counting rates in detectors of this type. Pulses are processed in parallel by a high-speed, four-channel discriminator circuit and by a slower pulse-height analyzer system. The pulse-pair resolution of the discriminators is approximately 300 ns. The nominal equivalent energies of the upper three discriminators for the LADs are 50, 100, and 300 keV. The lower-level discriminator is programmable, with a typical level of 30 keV. Two of the fast discriminators for the SDs are set at energies above the energies analyzed by the pulse height system. The gain of each detector system is determined by the high voltage applied to the PMTs. The SDs will be operated at different gains, in order to span from 15 keV to greater than 100 MeV. The nominal energy ranges of the SDs are shown in Table 2.

BATSE SPECTROSCOPY DETECTORS
Energy Ranges

GAIN	NUMBER OF DETECTORS	DISPERSION	SPECTRAL ANALYSIS	HIGH ENERGY DISCRIMINATORS
High (4X)	4	1 KeV/ch.	15 keV - 2.7 MeV	5 MeV, 11 MeV
Medium (1X)	2	4 KeV/ch.	60 keV - 11 MeV	22 MeV, 45 MeV
Low (0.4X)	2	10 KeV/ch.	150 keV - 27 MeV	54 MeV, 110 MeV

Table 2. Spectroscopy Detector planned operating gains.

2.4. Digital Data System

Each of the eight BATSE detector modules sends data to the Central Electronics Unit (CEU). The CEU contains hardware and software that accumulates the data into several large RAM memory buffers. Extensive use of commandable parameters, plus the capability to reprogram the flight software after launch, insures that BATSE will have the flexibility to respond to unforeseen conditions in orbit, or newly discovered gamma-ray phenomena. The functions of the BATSE data system are summarized in Figure 5. Signals from the pulse-height converters are used to construct 128-channel spectra from the LADs and 256-channel spectra from the SDs. Each of the spectra are subdivided into ranges with different dispersions to increase the dynamic range and to efficiently use the available telemetry space. These energy channels are also mapped into 16 coarse

energy channels using programmable look-up tables, one for the LADs and one for the SDs. This permits the trade of time resolution for energy resolution in several of the data types. Discriminator events are accumulated in the hardware every 64 ms. The CEU hardware constructs various data types from the discriminators, 16-channel, 128-channel, and 256-channel spectral data.

BATSE provides a signal to the other GRO instruments if a triggered burst appears to be a solar flare. This signal may be used by COMPTEL to enter the neutron detection mode and by OSSE to point to the Sun, if available to the OSSE detectors. The main criterion for generating the solar flare trigger signal is that the relative count rates are consistent within upper and lower limits for a burst coming from the direction of the Sun. Other criteria are that the detectors most directly facing the Sun must be triggered, that the hardness ratio must be between specified limits, and that the maximum count rate must be above a specified lower limit. These criteria are applied after data have been accumulated for a specified time, nominally 2 s after the burst trigger. The OSSE team will specify the values of the various parameters.

BATSE DATA PROCESSING

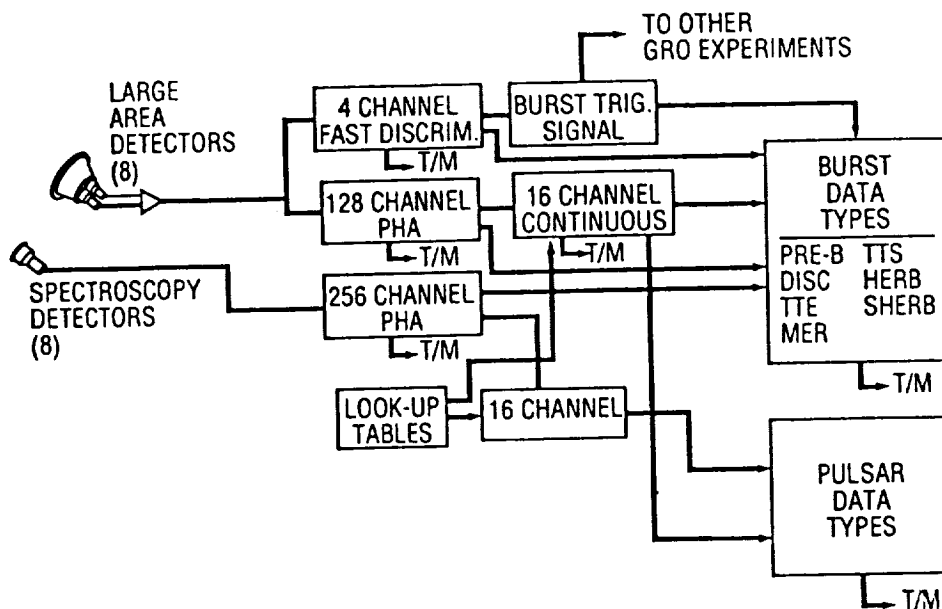

Figure 5. Overview of the BATSE onboard data system, showing principal data flows.

3. EXPERIMENT OPERATIONS AND SOLAR HARD X RAY MONITORING

BATSE is the only one of the four GRO instruments that can receive and analyze a large fraction of the data within days after observation. An extensive body of mission operations and data analysis software is being developed to derive gamma-ray burst locations, spectra, and counting rate histories soon after triggered events occur. Principal characteristics of the stronger gamma-ray bursts and solar flares will be made available to the scientific community in a timely manner via a common electronic bulletin board. We also expect to make available to the solar community hard x-ray data from the large-area detectors with 1 s resolution. This may be accomplished through the HXRBS/SMM analysis system at GSFC, according to recent discussions (B. Dennis, personal communication).

4. DATA ANALYSIS OPERATIONS

The primary facility for analysis of BATSE data will be located at NASA/Marshall Space Flight Center (MSFC). Additional facilities at NASA/Goddard Space Flight Center (GSFC) and the University of California, San Diego (UCSD), will be capable of implementing a subset of the functions of the primary facility. Guest Investigator support will be available at the primary analysis facility during the GRO mission.

The BATSE data archive is stored on the Marshall Archival System (MARS), an optical disk storage system which is maintained by MSFC for archival of flight data from various experiments. The other components of the primary data base are stored initially on magnetic disk, with archival backups to either local optical disk or magnetic tape. Analysis using a particular technique generally will proceed by generation of the appropriate secondary data base using the archived raw data combined with the calibration data, quality criteria, spacecraft parameters, and the BATSE instrument model. Subsequent analysis results and processed data are stored in tertiary Processed Data Bases (PDBs) which are managed using the commercially-available INGRES data base management system. Burst and solar flare catalogs are maintained and will be made available for public access. Software analysis tools consist primarily of display programs, spectral analysis functions such as line-fitting, and temporal search algorithms. A primary component of all data analysis is spectral analysis, including line searches and spectral deconvolution. A software package, the BATSE Spectral Analysis Software (BSAS) is being developed for this purpose by BATSE co-investigators at GSFC and it will be transported to other BATSE team facilities at MSFC and UCSD. Though primarily intended for analysis of burst spectra, the package will also be used for any spectral studies in the other analysis modes.

Three types of secondary data bases are produced for data analysis: the Individual Burst Data Base (IBDB), the Background Data Base (BDB), and the Pulsar Corrected Data Base (PCDB). At MSFC, these are created as needed for a specific application from the Primary Production Data Base and generally not archived. The IBDB and BDB formats are used to distribute a subset of the BATSE data to co-investigators at GSFC and UCSD, where local archives of these data bases are maintained. Within the GRO Guest Investigator (GI) program (Bunner 1989) a significant distinction is made between high-level and low-level data. The high-level data products will be analyzable in a relatively independent manner whereas use of low-level data will require close collaboration with the Principal Investigator (PI) team, typically involving a period of residence at a PI institution.

Any data which can be stored in a BATSE PDB are, in principle, available as high-level data. Standard sets of time histories and pulse-height spectra (with associated response matrices and calibration parameters) will be produced for each burst, solar flare, pulsar (onboard folding only), and bright occultation source. High-level data will be available either in Flexible Image Transport System (FITS) format or in the BATSE PDB format. The latter will be useful if the BSAS package is transported to another system.

The remaining BATSE data are available to Guest Investigators as low-level data. Once the GI attains sufficient familiarity with the instrument characteristics and analysis techniques, arrangements to transport relevant software and/or low-level data to another institution will be considered on a case-by-case basis. Catalogs of BATSE observations/investigations of bursts, solar flares, occultation sources, and pulsar sources will be generated during data analysis. Data analysis catalogs of bursts, solar flares, occultation sources, and pulsar sources will be available for public inspection via remote logon over the Space Physics Analysis Network (SPAN). Access via other means is being considered.

Access to low-level data will be available at MSFC beginning in the first year. We anticipate supporting from two to four Guest Investigators during the first year. Standard high-level data products will be available from MSFC during the second year. The standard high-level data products will also be incorporated into NASA's Astrophysics Data System (ADS). We plan to deliver data in FITS format to the appropriate ADS node within one year after receipt of data in usable form.

5. GUEST INVESTIGATIONS FOR SOLAR STUDIES

Numerous opportunities will exist for detailed studies of individual flares from solar flare-triggered BATSE data. The BATSE experimenters intend to make approximately 50% of the solar data available to guest investigators. For those flares that trigger the BATSE burst data system, hundreds of spectra will be accumulated over the duration of the flare. During the intense portions of many flares, time resolutions of tens of microseconds should be available with some limited spectral information. This should put severe constraints on the spatial distribution and evolution of high energy electron populations within the flare region. In addition to the electron component of flares, the high energy ion component from several MeV to several GeV can be studied through the emission of gamma-ray lines, pion decay, the decay of positron-emitting isotopes, and neutrons. Each of these species will have different temporal relationships with the flares, permitting additional insight into the spatial and temporal characteristics of the high energy ions within the flare regions. Gamma-ray line and neutron observations will be available with a higher time resolution than were possible from the GRS experiment on SMM.

Although not designed as a solar experiment, BATSE should be able to provide extensive, sensitive coverage of high-energy emission from the Sun during the present solar maximum.

References:

"BATSE: The Burst and Transient Source Experiment on the Gamma Ray Observatory", G.J. Fishman, C.A. Meegan, R.B. Wilson, W.S. Paciasas, T.A. Parnell, R.W. Austin, J.R. Rehage, J.L. Matteson, B.J. Teegarden, T.L. Cline, B.E. Schaefer, G.N. Pendleton, F.A. Berry, Jr., J.M. Horack, S.D. Storey, M.N. Brock, and J.P. Lestrade, GRO Science Workshop, GSFC, Proceedings to be published (1989a).

"The Burst and Transient Source Experiment (BATSE) Scientific Objectives and Capabilities", G.J. Fishman, C.A. Meegan, R.B. Wilson, W.S. Paciasas, T.A. Parnell, J.L. Matteson, B.J. Teegarden, T.L. Cline, G.N. Pendleton, and B.E. Schaefer, GRO Science Workshop, GSFC, Proceedings to be published (1989b).

"The BATSE Data Analysis System and Implementation of the Guest Investigator Program", W.S. Paciasas, G.N. Pendleton, G.J. Fishman, C.A. Meegan, R.B. Wilson, M.N. Brock, F.E. Roberts, and B.E. Schaefer, GRO Science Workshop, GSFC, Proceedings to be published (1989a).

"The BATSE Detector Response Matrices", G.N. Pendleton, W.S. Paciasas, J.P. Lestrade, G.J. Fishman, R.B. Wilson, and C.A. Meegan, GRO Science Workshop, GSFC, Proceedings to be published (1989).

"The Gamma Ray Observatory Guest Investigator Program", A.N. Bunner, GRO Science Workshop, GSFC, Proceedings to be published (1989).

"Performance of the Large Area Detectors for the Burst and Transient Source Experiment (BATSE) on the Gamma Ray Observatory", W.S. Paciasas, G.N. Pendleton, J.P. Lestrade, G.J. Fishman, C.A. Meegan, R.B. Wilson, T.A. Parnell, R.W. Austin, F.A. Berry, Jr., J.M. Horack, and S.D. Storey, SPIE Proceedings Vol. 1159, paper #1159-18, in press (1989b).