

480-12506

LOCKHEED LAMINAR-FLOW CONTROL SYSTEMS
DEVELOPMENT AND APPLICATIONS

Roy H. Lange
Lockheed-Georgia Company
Marietta, GA

PRECEDING PAGE BLANK NOT FILMED

ABSTRACT

This paper summarizes progress at the Lockheed-Georgia Company from 1974 to the present in the practical application of laminar-flow control (LFC) to subsonic transport aircraft. Those efforts include preliminary design system studies of commercial and military transports and experimental investigations leading to the development of the leading-edge flight test article installed on the NASA JetStar flight test aircraft. The benefits of LFC on drag, fuel efficiency, lift-to-drag ratio, and operating costs are compared with those for turbulent flow aircraft. The current activities in the NASA Industry Laminar-Flow Enabling Technologies Development contract include summaries of activities in the Task 1 development of a slotted-surface structural concept using advanced aluminum materials and the Task 2 preliminary conceptual design study of global-range military HLFC transports. The final section in the paper addresses the need for an experimental flight program on a swept wing aircraft with hybrid laminar-flow control (HLFC) to obtain data at high Reynolds numbers and at Mach numbers representative of long-range subsonic transport aircraft operation.

INTRODUCTION

Among the many concepts for aircraft drag reduction, laminar-flow control (LFC) has indicated the greatest potential for skin-friction drag reduction. A review of early progress since 1939 in analytical and experimental investigations of boundary-layer transition and methods for achievement of laminar flow is contained in a paper by Braslow and Muraca (ref. 1). The achievement of laminar-flow control in flight was obtained by the British on Vampire aircraft in 1951-1955 and the U.S. Air Force/Northrop tests on the F-94 and X-21 in the mid 1950's and early 1960's. The X-21 program was a significant milestone not only for the extensive regions of laminar flow obtained in flight at chord Reynolds numbers up to 40 million but also for the LFC design criteria established and validated and crossflow instabilities identified due to wing sweepback (refs. 2-5). The premature termination of the X-21 program prevented the accumulation of the desired data base on service experience for an operational aircraft, and thus the economics and day-by-day reliability of an LFC aircraft still remain uncertain.

The Lockheed motivation in LFC activities has been directed to the eventual application to long-range or long-endurance military strategic aircraft systems. Early work includes the application of LFC by Lockheed and Northrop in 1962 on the C-141 aircraft and in 1966 on the C-5A (ref. 6). However, little further work was done on LFC until the effects of the fuel crisis in 1973 directed attention to the use of advanced technologies for improved fuel efficiency. Another significant milestone occurred when LFC was reactivated as one of the elements in the NASA Aircraft Energy Efficiency, ACEE, program in 1976 (refs. 7-9) and is continuing to the present.

This paper summarizes progress at the Lockheed-Georgia Company from 1974 to the present in the practical application of LFC to subsonic transport aircraft. These efforts include preliminary system design studies, airfoil development, boundary-layer analyses, integrated structural design, the suction system, manufacturing methods, and a final integrated aircraft configuration. Experimental investigations include wind tunnel tests, low-speed flight tests, and tests of structural specimens. The benefits of LFC on drag, fuel efficiency, and operating costs are compared with current as well as a counterpart advanced technology turbulent transport. The

development of the leading-edge flight test article installed on the NASA JetStar flight test aircraft is discussed. A review of the above activities since 1974 is given in an AIAA paper by Lange (ref. 10). The current efforts in the NASA Laminar-Flow Enabling Technologies Development contract include summaries of activities in the Task 1 development of a slotted-surface structural concept using advanced aluminum materials and the Task 2 preliminary conceptual design study of global-range military HLFC transports. The paper also addresses the need for a flight experimental program on a swept wing aircraft with HLFC to obtain data at high Reynolds numbers and at Mach numbers representative of long-range subsonic transport aircraft operation.

LFC PROGRAM HISTORY

NASA, in concert with industry, has been sponsoring LFC technology development activities for the past 11 years to achieve LFC technology readiness in the 1990's. NASA/Lockheed LFC contract efforts presented in Figures 1 and 2 cover a time span from 1974 to mid 1986. These charts are provided as background material and only the highlights will be discussed in this paper. The reader is provided with references to these activities for more details. Lockheed Independent Research and Development is identified in these figures and these activities have been devoted primarily to preliminary system design studies of large payload, long-range military airlift aircraft. As shown in Figure 1, Lockheed performed the initial feasibility study of advanced technology LFC aircraft beginning in October 1974. The favorable results of this initial study provided the impetus to additional investigations of LFC outer skin panels (ref. 11), a JetStar leading-edge flap modification (ref. 12), a study of cruise noise/LFC noise criteria, and the evaluation of LFC system concepts (refs. 13-15).

On April 6-7, 1976, the NASA-Langley Research Center conducted a Workshop on Laminar-Flow Control. The program was arranged as a forum for informal papers and discussions on LFC experience from government and industry. Included in the discussions were the effects of advances in technology on the performance and costs of LFC, the outlook for LFC as perceived by government and industry, and critical concerns and possible solutions. One result of the Workshop was additional contacts by Lockheed with airlines and other aircraft operators relative to LFC transport aircraft. A consensus of industry and airline concerns on LFC was obtained. Three major areas of concern include the development of LFC structure and subsystems with acceptable weight and cost, problems of manufacturing of the required LFC structure, and the operational reliability on a day-by-day basis. The following sections of this paper review the status of NASA and industry activity up to the present time related to these concerns.

Major LFC development programs funded in 1980 under the NASA ACEE program shown in Figure 2 include wing surface panel structural development (refs. 16 and 17) and the design, fabrication, and flight test of leading-edge articles (ref. 18). Because of the loss in NASA funding, the wing structural development program was terminated in 1981 before progress on major objectives could be made. The leading-edge flight test article program will be discussed in a later section. Modifications were made to the NASA-Langley Research Center 8-Foot Transonic Tunnel to accommodate a special sweptback, slotted-surface, laminar-flow control airfoil (ref. 19). The objective of continuing tests is to evaluate the effectiveness of suction through both slotted and perforated surfaces in supercritical flow. The airfoil is mounted at a fixed

angle of attack for a lift coefficient of 0.55, and test conditions include Mach numbers up to 0.82 and Reynolds numbers up to 20 million (ref. 20).

SYSTEM STUDIES RESULTS

The intensive evaluation of LFC system concepts in NASA contract NAS1-14631 (ref. 15) resulted in the preliminary design of the Lockheed LFC transport shown in Figure 3. It is a wide-body configuration designed to carry 400 passengers and baggage over an intercontinental range of 6500 nautical miles at $M = 0.80$ cruise speeds with adequate fuel to account for adverse winds, intermittent LFC disruption due to atmospheric conditions at cruise, and international fuel reserves. The total payload of the aircraft including passengers and baggage is 84,800 pounds.

The general arrangement drawing of the Lockheed LFC transport aircraft is presented in Figure 4. The aircraft is a low-wing T-tail monoplane with four aft-mounted engines. An independently driven LFC suction unit is located in a fairing under each wing root. Fuel is carried in the wing, including the wing center-section box. The wing has 25° sweep at the leading edge, an aspect ratio of 11.6, and a wing loading of 111.8 pounds per square foot. Full-span flaps, including drooped ailerons, provide the required airport performance for a 10,000-foot runway. Leading-edge, high-lift devices are not required. Partial-span spoilers are provided. Small-chord (10 percent) secondary flaps incorporated into the main flaps provide upper surface pressure gradient and shock position control for off-design operation, and serve as active controls to minimize structural requirements. The takeoff gross weight of the aircraft is 592,205 pounds. LFC suction capability is provided on upper and lower wing surfaces from 0 to 75 percent chord and on the empennage from 0 to 65 percent chord. The effectiveness of the Lockheed design approach in the integration of LFC-peculiar items resulted in the relatively low weight of 4.4 percent of the empty weight incurred for LFC. The dedicated slots at the leading edge for dispensing the flow of a liquid to prevent contamination of the surface during takeoff and climb out required an amount of fluid per flight which is 2.6 percent of the gross weight of the aircraft.

The benefits of LFC shown in Figure 5 were determined by comparison of the performance of the LFC aircraft and an equivalent advanced technology turbulent aircraft which performed the same mission as that of the LFC aircraft. The calculations of aircraft drag indicate a 60 percent reduction in the wing and empennage drag, resulting from the effects of LFC in reducing skin-friction drag. The corresponding reduction in total aircraft drag due to LFC is 15 percent. The weight empty of the LFC aircraft is about 1 percent greater than the turbulent aircraft but the takeoff gross weight of the LFC aircraft is 8 percent lower, primarily due to the 22 percent reduction in fuel required for the long-range mission. The lower fuel burned provides a 4 percent reduction in direct operating costs (DOC).

During the time period of the intensive system evaluation studies of commercial LFC transport studies under contract NAS1-14631, Lockheed was continuing its preliminary design studies of military cargo airlift aircraft under Independent Research and Development projects. A general arrangement drawing of one of the military LFC transports presented in Figure 6 shows a $M = 0.68$ cruise speed with four times the payload of the 400 passenger commercial transport in the NASA study. With a lower amount of sweep in the wing, the aspect ratio was increased to 15, and for the 6000-nautical-mile-range capability, the takeoff gross weight is about 1.2 million pounds. The results of these military LFC transport studies were presented at a

special meeting on laminar-flow control conducted by the Defense Advanced Research Projects Agency on May 2, 1978. The parametric study included cruise Mach numbers from 0.65 to 0.80 and ranges from 6,000 nautical miles to 12,000 nautical miles. Fuel savings of 16 percent were indicated for the laminar-flow control aircraft as compared to that for the turbulent flow aircraft for the same mission characteristics.

NASA LEADING-EDGE SYSTEMS FLIGHT TEST PROGRAM

Encouraged by the progress made in the development and validation of leading-edge cleaning, anti-icing, and suction systems so vital to the success of an LFC transport, Lockheed and Douglas developed flight test articles with NASA funding that were installed and tested on the NASA-Dryden Flight Research Facility JetStar aircraft. The Lockheed activity is reported in reference 18. An early review of the total NASA program is given by Wagner and Fischer in reference 21. In addition to the development of the leading-edge test article, Lockheed had the added responsibility for providing the aircraft structural and support system design and integration.

The schematic diagram in Figure 7 shows the NASA JetStar flight test airplane with the McDonnell-Douglas perforated leading-edge flight test article on one wing and the Lockheed slotted test article on the other wing. Both LFC suction concepts are logical candidates, and the flight tests were made to determine the effectiveness of these system concepts for leading-edge cleaning, anti-icing, and cruise suction LFC conditions. The test articles were instrumented for measuring boundary-layer conditions, suction flows, and other basic aircraft flight parameters. After ground and flight check-out and acceptance tests, the aircraft was operated in a simulated airline service phase to accumulate the operational flight data required. The total flight program is reviewed by NASA in reference 22.

The Lockheed leading-edge test article shown in a cross-section view in Figure 8 is a sandwich construction consisting of a 0.016-inch-thick titanium outer skin bonded to a substructure of graphite/epoxy face sheets with a Nomex honeycomb core.

Suction slots are cut in the titanium outer skin by a high-speed steel jeweler's saw to provide fine spanwise slots about 0.0035 inch wide on both upper and lower surfaces back to the front spar location. The suction flow passes through the wing outer skin into slot ducts which have metering holes into the collector ducts imbedded in the honeycomb. The insert protection and anti-icing are accomplished by dispensing the cleaning/anti-icing fluid over the wing surface through the slots above and below the wing flow attachment line as denoted by slots C and D on Figure 8. These slots are purged of the fluid during climbout and provide suction to achieve laminar flow at cruise conditions in combination with the slots denoted by U and L.

A problem in fabrication of the leading-edge test article was discovered upon suction flow check out of the final article. It was determined that migration of the adhesive during the titanium-to-graphite faced core bonding process had plugged up a few of the slots, metering holes on collector ducts in a random manner on the test article. The attendant loss of suction flow in these locations prevented the local attainment of conditions necessary for laminar flow. As a result, the attainment of laminar flow over the entire test article could not be realized during the flight testing.

A close-up photograph of the Lockheed test article installed on the NASA JetStar LFC flight test aircraft is provided in Figure 9. Figure 10 is a photograph of the aircraft in flight.

LAMINAR FLOW ENABLING TECHNOLOGY DEVELOPMENT

At a meeting held at the NASA-Langley Research Center on January 19-20, 1984, NASA discussed plans for LFC new initiatives and technology development with representatives from Boeing, McDonnell-Douglas, and Lockheed. These discussions eventually resulted in request for proposals (RFP) being released for laminar flow enabling technologies development and the award of task-type contracts to Boeing, McDonnell-Douglas, and Lockheed.

In order to provide for a near-term application of laminar-flow control, a more simplified concept referred to as hybrid laminar-flow control (HLFC) has been established for current activities. The HLFC concept, shown in Figure 11, has the active suction system restricted to the region ahead of the front spar of the wing. Aft of the active suction region the airfoil shape is tailored to achieve the maximum extent of laminar flow, and this is expected to extend to 50 percent or more of the wing chord. HLFC studies by Boeing are reported in reference 23. The HLFC concept avoids a number of concerns by the industry and the airlines, in particular, suction surfaces and ducting are not required in the main wing box areas which also contain the fuel for the aircraft. Thus the weight and complexity of the suction systems is greatly reduced and the possible hazards with the fuel are eliminated. The suction in the leading-edge region can control the cross flow disturbances for swept wings and the airfoil tailoring over the wing box can stabilize two-dimensional disturbances.

The two tasks in the NASA/Lockheed Laminar-Flow Enabling Technology Development Contract No. NAS1-18036 are listed in Figure 12 and will now be discussed. Contract NAS1-18036 is a 48 month task-type contract that was effective in December 1985. The NASA/Industry Laminar-Flow Enabling Technology Development Program is another significant step in the path leading to the achievement of the potential benefits of LFC for future transport aircraft.

TASK 1 - ADVANCED ALUMINUM SLOTTED-SURFACE STRUCTURAL CONCEPT DEVELOPMENT

The primary objective of Task 1 was to design and fabricate a small demonstration article as shown in Figure 13. This new structural arrangement of a slotted surface uses advanced aluminum material and manufacturing techniques. The program demonstrates the producibility of the design using a powder metal aluminum alloy outer skin, superplastic forming, diffusion bonding, and a low density aluminum-lithium inner skin. Fabrication techniques were selected to eliminate assembly difficulties encountered in the previous composite design of the JetStar flight test article.

The bonded assembly was placed in an indexing fixture which rates the part for slotting. Slotting was done with a 1-inch-diameter jeweler's saw with an 0.0025 inch thickness. The saw was mounted on a motor set up on a computer-controlled gantry.

Slot widths of 0.003 were obtained with this process on the demonstration article. Powder aluminum IN9052 was selected for the outer skin because of its high corrosion resistance properties similar to titanium used in the previous test articles. Thus the slots cut in this material should maintain their desired geometry and not degrade with time and operation.

A close-up view of a single spanwise duct in Figure 14 shows the materials and joining processes. The outer skin and the inner sheet used to form the slot duct are fabricated from powder metal aluminum alloy IN9052 and diffusion bonded using a Texas Instruments bonding and expansion process. Diffusion bonding was selected in this area because of its high shear strength and to avoid the use of adhesive bonding in the slot, slot duct, and metering hole regions. Texas Instruments, located in Attleboro, Massachusetts, was selected to fabricate the outer skin and slot ducts.

Texas Instruments uses a cold roll bonding process. Prior to bonding, metal surfaces are chemically and mechanically cleaned to provide contaminant-free surfaces. Bonding is achieved by passing the metal sheets through a specially designed rolling mill where extremely high reduction in the sheet gages forces the layers into intimate contact. During this bonding process, the new surface is exposed, providing bonding surfaces which are virtually defect-free. A thermal expansion process is introduced by placing stop-off materials between the layers of metal before bonding. This thermal treatment causes the material to expand into shaped dies at the locations of the stop-off. The end result is a shaped configuration of the slot duct diffusion bonded to the outer skin, with shear strengths nearly equal to the shear strength of the monolithic alloy.

The collector duct is superplastically formed from 7475 aluminum alloy. The structure is closed using low-density aluminum-lithium alloy. Interfaces between the slot duct sheet and the collector duct and between the collector duct and the aluminum-lithium inner skin are adhesively bonded using FM300 adhesive.

Lockheed was responsible for the fabrication of the inner portion of the demonstration article including the collector duct and inner skin and for the final assembly.

Photographs of a sample of the outer skin and slot duct cross section and of a top view showing the slots are provided in Figure 15.

TASK 2 - GLOBAL RANGE MILITARY TRANSPORT STUDY

The objective of Task 2 was to determine by means of preliminary system design studies the benefits derived from the use of hybrid laminar-flow control (HLFC) for military transports designed to achieve the payload/range requirements of global range aircraft. As shown in Figure 16 the Air Force Project Forecast II effort has identified system PS-03 Multirole Global Range Aircraft as a subsonic element in global force projection. It is anticipated that this global range aircraft must have exceptional aerodynamic and propulsive efficiency to achieve the mission characteristics. Previous Lockheed preliminary design studies have shown significant increase in aerodynamic efficiency by the application of LFC to military transport aircraft. It is also expected that the HLFC or natural laminar flow, NLF, will also provide improved efficiency for System PS-05 High-Altitude, Long-Endurance, Unmanned Aircraft, the PS-22 Multimission Remotely Piloted Vehicle, and the PS-35 Airborne Surveillance System.

A recent study of military laminar-flow control transport aircraft was conducted by Lockheed under an Air Force contract study, "Technology Alternatives for Airlift Deployment" (ref. 24). A sketch of the military LFC transport given in Figure 17 is for a Mach 0.80 cruise aircraft with a payload of 212,000 pounds, a range of 5800 nautical miles, and a takeoff gross weight of 786,700 pounds. The aircraft utilized LFC from the leading edge back to 65 percent of the wing chord and to 75 percent chord on the empennage surfaces. As compared to a comparable turbulent flow transport the LFC transport showed a 40 percent increase in range for the same payload but with an attendant 10 percent increase in structural weight.

The laminar-flow control transport showed a 14 percent reduction in mission fuel as compared to that for the turbulent flow aircraft. The fuselage-mounted engine location is a compromise among considerations of weight and balance, nose wheel lift off at takeoff and, of course, avoidance of wing-mounted engines.

The scope of the Task 2 preliminary design study of contract NAS1-18036 is included in five study elements: (1) Basic Data Assumptions, (2) Mission Characteristics, (3) Configuration Development, (4) Configuration Selection, and (5) Analysis of Laminar-Flow Benefits. In element (1), the approach is to utilize the technology data base in the Lockheed Generalized Aircraft Sizing and Performance (GASP) computer program used in the Air Force Technology Alternatives for Airlift Deployment (TAFAD) study. Modification is made to the data base to account for the change to the hybrid laminar-flow control concept from the previous LFC concept. Mission characteristics such as payload, range, cruise Mach number, airfield performance, and operational concepts have been mutually agreed upon among NASA, the Air Force, and Lockheed. The baseline mission characteristics presented in Figure 18 are based upon the following considerations: the payload of 132,500 pounds is generic for multi-purpose missions of the Air Force under study by Lockheed under AFWAL contract (see ref. 25); cruise speed of Mach 0.77 will be increased to Mach 0.80; initial cruise altitude will be a fallout to provide best cruise efficiency for the Pratt & Whitney STF-686 turbofan propulsion system and initial results of about 31,000 feet were increased to 36,000 feet; the initial takeoff field length and field length at the midpoint are representative of those for long-range transoceanic flights; and the radius-type payload/range with no refueling at the mid-point provides military force projection to many parts of the world of interest to the Air Force. The range capability provides access to Pacific Rim countries which are important to operators of commercial transport aircraft.

The HLFC design ground rules listed in Figure 19 are, with a few exceptions, basically self-explanatory and consistent with previous LFC studies. Turbulent flow is assumed to occur during 6 percent of cruise time to assure mission completion should atmospheric conditions preclude the use of HLFC for short periods during cruise. The 12 percent excess cruise thrust provides the capability to maintain cruise altitude and/or speed with the HLFC system inactive. The wing sweep was varied for both the HLFC and comparison turbulent flow aircraft in the parametric sizing studies as will be discussed later. The number in the flight crew provides for rest cycles for this long-range mission. It was assumed that technology readiness of 1994 will provide an initial operational capability (IOC) for the year 2000.

Results of the ongoing parametric design studies of Task 2 are provided in Figure 20 of an initial baseline HLFC design concept for the long-range mission and at a cruise Mach number of 0.77. The design concept features the fuselage-mounted engines similar to the previous Air Force TAFAD study (ref. 24). In addition, geometric features include a wing sweep of 20° , an aspect ratio of 13.86, and a wing span of

259 feet. Performance characteristics include a takeoff gross weight of 594,548 pounds, mission fuel of 253,330 pounds, and a lift-to-drag ratio of 30.9. As mentioned earlier, wing sweeps of 20° and 25° were investigated in the parametric sizing runs for the HLFC aircraft. A comparison of the parametric data for the two sweep cases showed mixed results with the 20° sweep design indicating slightly higher lift-to-drag ratio than the 25° design but the 25° design indicating slightly less fuel burned and takeoff gross weight. The 20° sweep design was selected because it was expected that less leading-edge cross flow would be encountered than that for the higher sweep design.

Parametric sizing data were derived for the turbulent flow aircraft with the wing sweep varying from 25° to 40° for identical mission requirements as those for the HLFC designs. The data indicate a superiority of the 30° sweep design based on an overall comparison of minimum fuel burned, maximum lift-to-drag ratio, and minimum takeoff gross weight. A general arrangement drawing of the baseline 30° sweep turbulent design presented in Figure 21 features wing-mounted engines, an aspect ratio of 13.5, and a wing span of 256 feet. Performance characteristics include a takeoff gross weight of 616,125 pounds, mission fuel of 291,401 pounds, and a lift-to-drag ratio of 26.

The benefits of HLFC presented in Figure 22 were determined by a comparison of the performance of HLFC designs with that for the baseline turbulent design, which performed the same mission as that of the HLFC designs. Data for the HLFC baseline design and two variations from that design are presented in the three columns of Figure 22 and the percentage changes are all referenced to the baseline turbulent design. As presented in the first column, the baseline HLFC design as compared to the baseline turbulent flow design indicates an increase in operating empty weight of 5.4 percent, a decrease in takeoff gross weight of 4 percent, a decrease in fuel consumption of 13.4 percent, and an increase in lift-to-drag ratio of 18.4 percent. The second column of Figure 22 shows the effects of deleting laminar-flow control from the empennage of the HLFC aircraft; and the results, as expected, are small with slightly higher aircraft weights, an improvement in the fuel consumption, and little change in the lift-to-drag ratio. The effects of deleting HLFC on the lower wing surfaces show significant adverse effects on aircraft weights, fuel consumption, and lift-to-drag ratio. As compared to the HLFC baseline aircraft, the overall effect of a decrease in lift-to-drag ratio of 32 percent and an increase in fuel consumption of 41 percent gives an increase in takeoff gross weight of 85 percent. Although not shown on Figure 22, an increase in initial cruise altitude of the HLFC design to 36,000 feet has a slightly adverse effect on the weights and fuel consumption and an improvement in the lift-to-drag ratio.

It should be noted that the aspect ratios of both turbulent flow and HLFC design concepts are relatively high as compared to the state-of-the-art and to near-term projections. Although a number of conceptual design studies have utilized design concepts with aspect ratios from 13 to 16 and even higher, there is concern that such aspect ratios will be achievable on a fully operational, flight worthy and certified aircraft in the next 5 to 10 years. The global range Task 2 study will address this concern with a study of a lower aspect ratio design.

In summary, these studies of the application of HLFC to global range military transport aircraft show a significant increase in lift-to-drag ratio (18 percent), decrease in fuel consumption (13 percent), and decrease in takeoff gross weight (4 percent) for a 5 percent increase in empty weight as compared to that for global range turbulent flow aircraft.

STATUS AND RECOMMENDATIONS FOR FURTHER WORK

It is clear that substantial progress has been made in the NASA/Industry technology development of laminar-flow control over the past 10 years as indicated in Figure 23. The recently completed flight tests of LFC leading-edge systems have successfully demonstrated solutions to leading-edge contamination. These tests have also obtained laminar flow over both slotted and perforated surfaces for a variety of flight conditions and from operation out of many airport operating environments.

The current NASA/Industry Laminar-Flow Enabling Technology Development projects initiated in 1985 are continuing to provide direction to the achievement of technology readiness for application of LFC to future long-range transport aircraft. As discussed previously the simplified HLFC concept reduces the complexity of LFC and thus provides for one more near-term application of this technology. The significant benefits of HLFC indicated in the global range aircraft studies described herein provide the justification for an accelerated effort to develop the desired data base on HLFC for application to long-range transport aircraft. With the present state of the art in HLFC technology, additional development is required especially for application to long-range transport aircraft in the high Reynolds number regime. The current LFC data base in wind tunnel and flight tests is limited to a maximum Reynolds number of about 20 million. This situation leads to the next logical step in the development of HLFC.

What is now needed in HLFC, as outlined in Figure 24, is an experimental flight program on a swept wing aircraft to obtain the required data at high Reynolds numbers, i.e., 30 to 50 million, and at cruise Mach numbers and altitudes representative of long-range transport operation. These tests are needed to obtain the physical flow properties of the boundary layer including leading-edge crossflow and two-dimensional disturbances aft of the leading edge and over the main wing box area. These data can only be obtained by means of flight tests on a representative subsonic speed, long-range aircraft. A program of this type is a logical extension of the ongoing NASA program in laminar flow and laminar-flow control research. Such a program has been discussed with NASA by Lockheed utilizing the C-141 as the flight test aircraft. To this end it is gratifying to note the issue of NASA RFP 1-42-3610.0049, "High Reynolds Number Hybrid Laminar-Flow Control (HLFC) Flight Experiment," in a cooperative effort with the Air Force Wright Aeronautical Laboratories. This flight investigation is envisioned as the final step in the achievement of the technology readiness for application of HLFC to long-range transport aircraft in the mid to late 1990's.

SUMMARY AND CONCLUSIONS

The summary and concluding remarks for this paper are outlined in Figure 25. Considerable progress has been made in the NASA/Industry LFC program from its inception in October 1974. Furthermore this work has provided the United States with a competitive edge over our foreign competitors. In order to maintain this edge, a high Reynolds number flight test program on a subsonic speed, swept wing aircraft with HLFC should be initiated at the earliest possible time. It is hereby noted that NASA has issued an RFP for such a program in a cooperative effort with the Air Force Wright Aeronautical Laboratories.

Industry as yet does not have the required data base to proceed with the design and fabrication of an HLFC aircraft for operational use. The global range aircraft

study has shown significant benefits for HLFC application on the order of an 18 percent increase in lift-to-drag ratio and a 13 percent reduction in fuel consumption as compared with turbulent flow aircraft. These results warrant an accelerated effort to develop the HLFC technology data base required for technology readiness.

REFERENCES

1. Braslow, Albert L., and Muraca, Ralph J., "A Perspective of Laminar-Fuel Control," AIAA Paper 78-1528, Los Angeles, CA, August 1978.
2. Antonatos, P. P., "Laminar Flow Control - Concepts and Applications," Astronautics and Aeronautics, July 1966, pp. 32-36.
3. Whites, R. C., Sudderth, R. W., and Wheldon, W. G., "Laminar Flow Control on the X-21," Astronautics and Aeronautics, July 1966, pp. 38-43.
4. Pfenninger, Werner, and Reed, Verlin D., "Laminar-Flow Research and Experiments," Astronautics and Aeronautics, July 1966, pp. 44-50.
5. Nenni, Joseph, and Gluyas, George L., "Aerodynamic Design and Analysis of an LFC Surface," Astronautics and Aeronautics, July 1966, pp. 52-57.
6. Chuprun, John, and Cahill, Jones F., "LFC on Large Logistics Aircraft," Astronautics and Aeronautics, July 1966, pp. 58-62.
7. Kramer, J. J., "Planning a New Era in Air Transportation Efficiency," Astronautics and Aeronautics, July/August 1978, pp. 26-28.
8. Conner, D. W., "CTOL Concepts and Technology Development," Astronautics and Aeronautics, July/August 1978, pp. 29-37.
9. Leonard, R. W., "Airframes and Aerodynamics," Astronautics and Aeronautics, July/August 1978, pp. 28-46.
10. Lange, R. H., "Design Integration of Laminar Flow Control for Transport Aircraft," Journal of Aircraft, Vol. 21, No. 8, August 1984, pp. 612-617.
11. Meade, L. E., Kays, A. O., Ferrill, R. S., and Young, H. R., "Development of the Technology for the Fabrication of Reliable Laminar Flow Control Panels," NASA CR 145168, prepared by the Lockheed-Georgia Company, October 1976.
12. Peterson, J. B., Jr., and Fisher, D. F., "Flight Investigation of Insect Contamination and Its Alleviation," NASA CP 2036, Part I, Feb.-Mar. 1978, pp. 357-373.
13. Sturgeon, R. F., "The Development and Evaluation of Advanced Technology Laminar-Flow-Control Subsonic Transport Aircraft," AIAA Paper 79-96, Huntsville, Alabama, January 1978.
14. Sturgeon, R. F., "Toward a Laminar-Flow Control Transport," CTOL Transport Technology 1978, NASA Conference Publication 2036, February 28 - March 3, 1978.

15. Sturgeon, R. F., "Evaluation of LFC System Concepts for Subsonic Commercial Transport Aircraft," NASA CR 159253, prepared by Lockheed-Georgia Company, Sept. 1980.
16. Lineberger, L. B., Beall, R. T., and Gilbert, G. J., "Development of Laminar Flow Control Wing Surface Composite Structures," NASA CR 172330, prepared by the Lockheed-Georgia Company, May 1984.
17. Lineberger, L. B., "Structural Tests and Development of a Laminar Flow Control Wing Surface Composite Chordwise Joint," NASA CR 172462, prepared by the Lockheed-Georgia Company, December 1984.
18. Etchberger, F. R., "LFC Leading Edge Glove Flight - Aircraft Modification Design, Test Article Development, and Systems Integration," NASA CR 172136, prepared by Lockheed-Georgia Company, Nov. 1983.
19. Harvey, W. D., and Pride, J. D., Jr., "NASA Langley Laminar Flow Control Airfoil Experiment," NASA CP 2218, September 1981, pp. 1-42.
20. Harvey, W. D., Harris, C. D., Brooks, C. W., Jr., and Bobbitt, P. J., "Experimental Results on a Swept Supercritical Airfoil With Suction via the Langley 8-Foot Transonic Pressure Tunnel." AIAA Shear Flow Control Conference, Boulder, Colorado, March 12-14, 1985.
21. Wagner, Richard D., and Fischer, Michael C., "Developments in the NASA Transport Aircraft Laminar Flow Program," AIAA Paper 83-0090, Reno, Nevada, January 1983.
22. Wagner, Richard D., Maddalon, Dal V., and Fischer, Michael C., "Technology Developments for Laminar Boundary Layer Control on Subsonic Transport Aircraft," presented at the 54th Meeting of the FLID Dynamics Panel Symposium on Improvement of Aerodynamic Performance Through Boundary Layer Control and High Lift Systems, Brussels, Belgium, May 21-23, 1984.
23. Anon., "Hybrid Laminar Flow Control Study," NASA CR-165930, prepared by Boeing Commercial Aircraft Company, October 1982.
24. Moore, J. W., Craven, E. P., Farmer, B. T., Simica, C. A., and Stevens, R. J., "Technology Alternatives for Airlift Deployment," Air Force Wright Aeronautical Laboratory Report AFWAL-TR-85-3001, prepared by Lockheed-Georgia Company, April 1985.
25. Smethers, Rollo G., and Honrath, John F., "Configuration Integration for Large Multi-Purpose Aircraft," Air Force Wright Aeronautical Laboratory Report AFWAL-TR-85-3075, prepared by Lockheed-Georgia Company, September 1985.

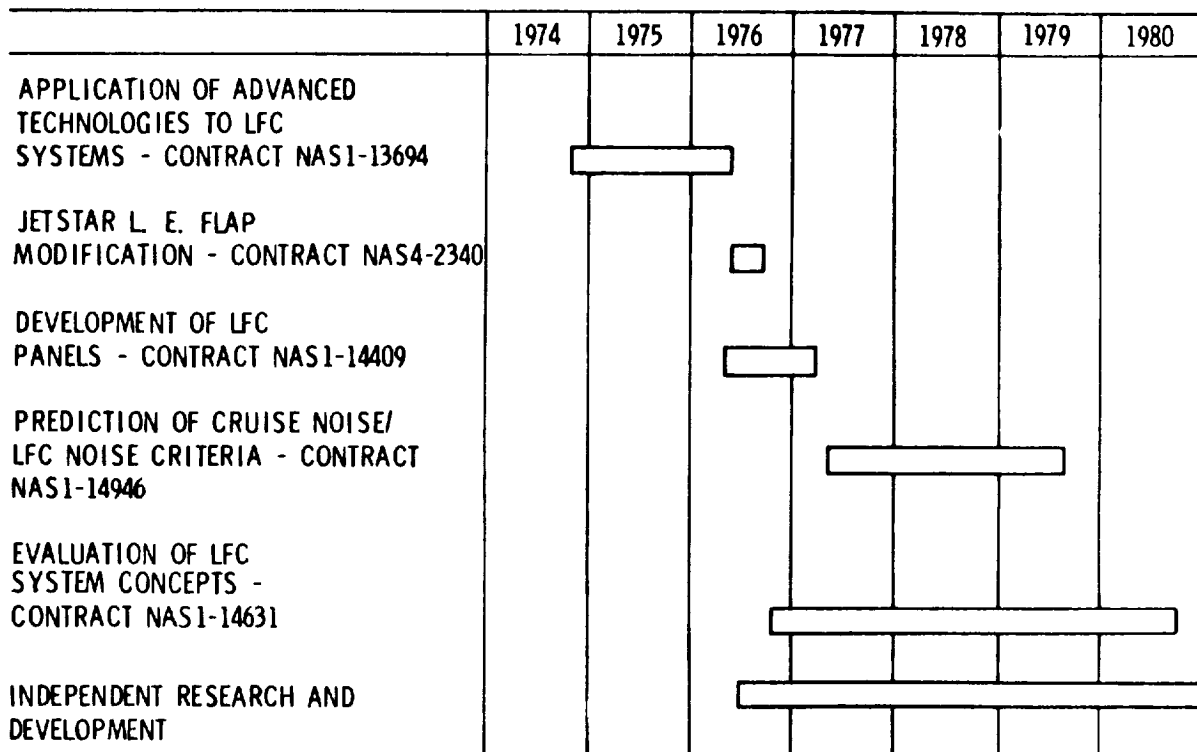

Figure 1. Lockheed LFC program history.

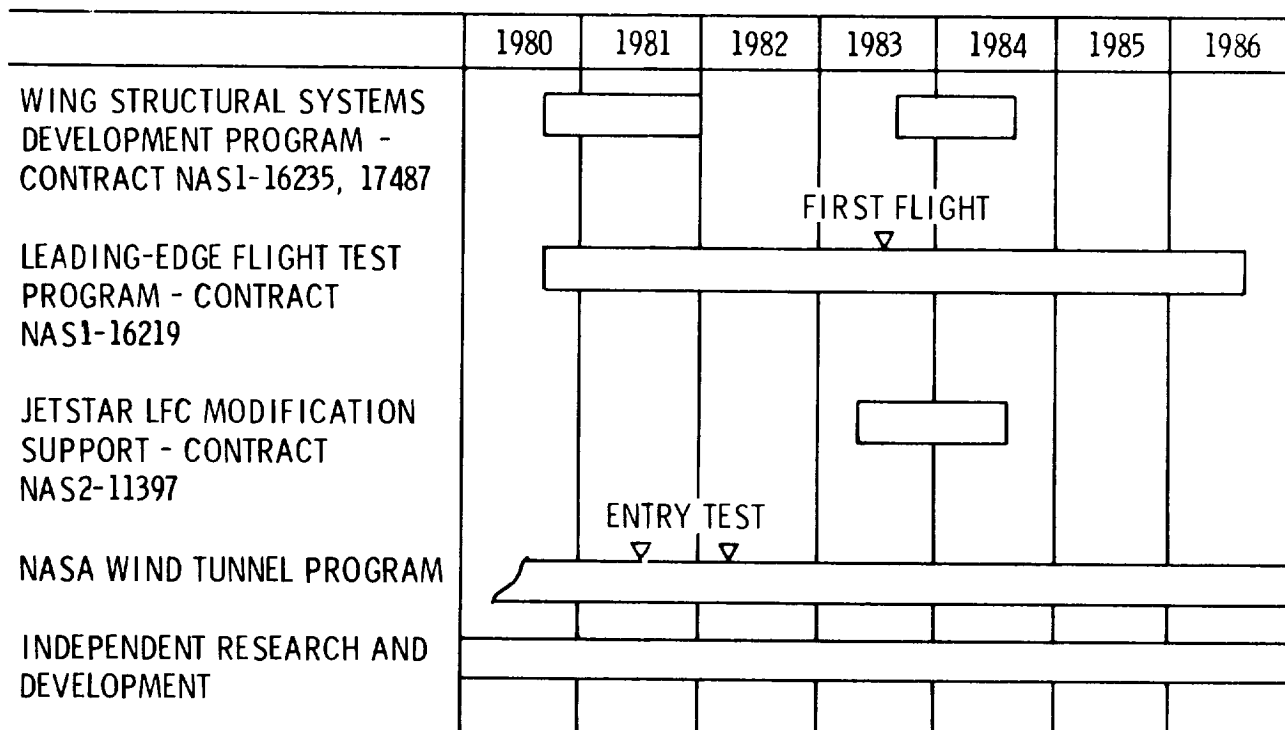

Figure 2. Lockheed LFC program history (Concluded).

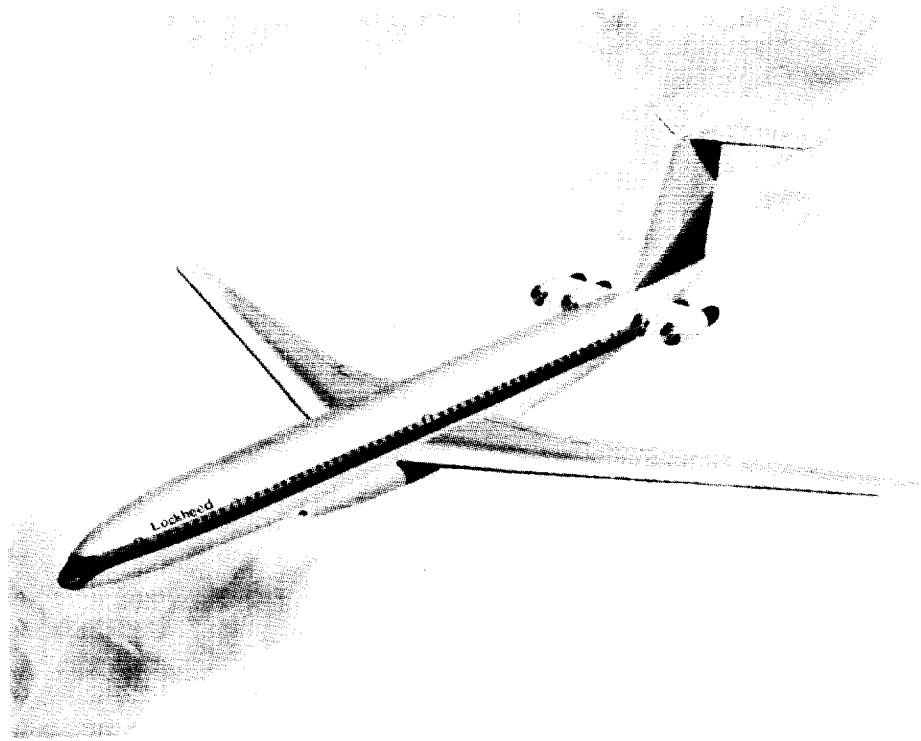

Figure 3. Laminar-flow control passenger transport.

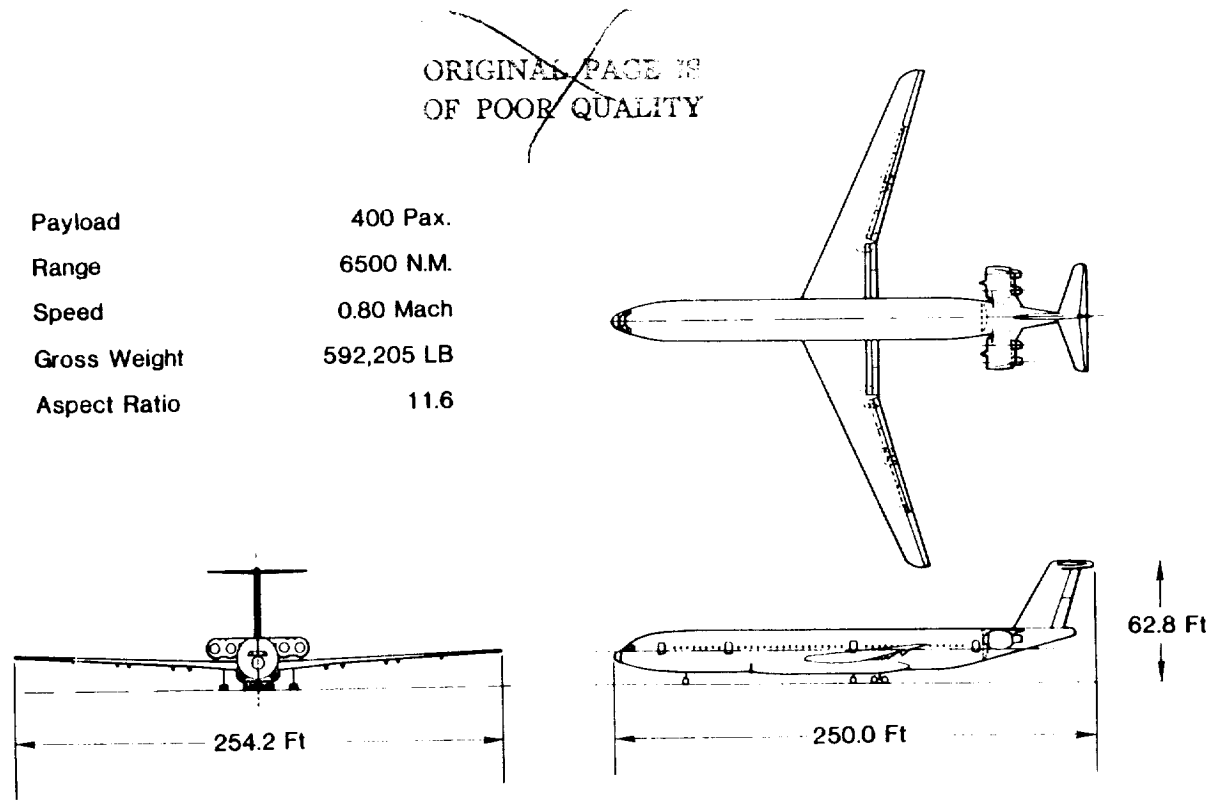

Figure 4. General arrangement of LFC transport.

	<u>Change-%</u>
Drag	
Wings/Empennage	- 60
Total Aircraft	- 15
Weight	
Empty Weight	+ 1
Gross Weight	- 8
Fuel Consumption	- 22
Direct Operating Cost	- 4

Figure 5. Benefits of laminar-flow control.

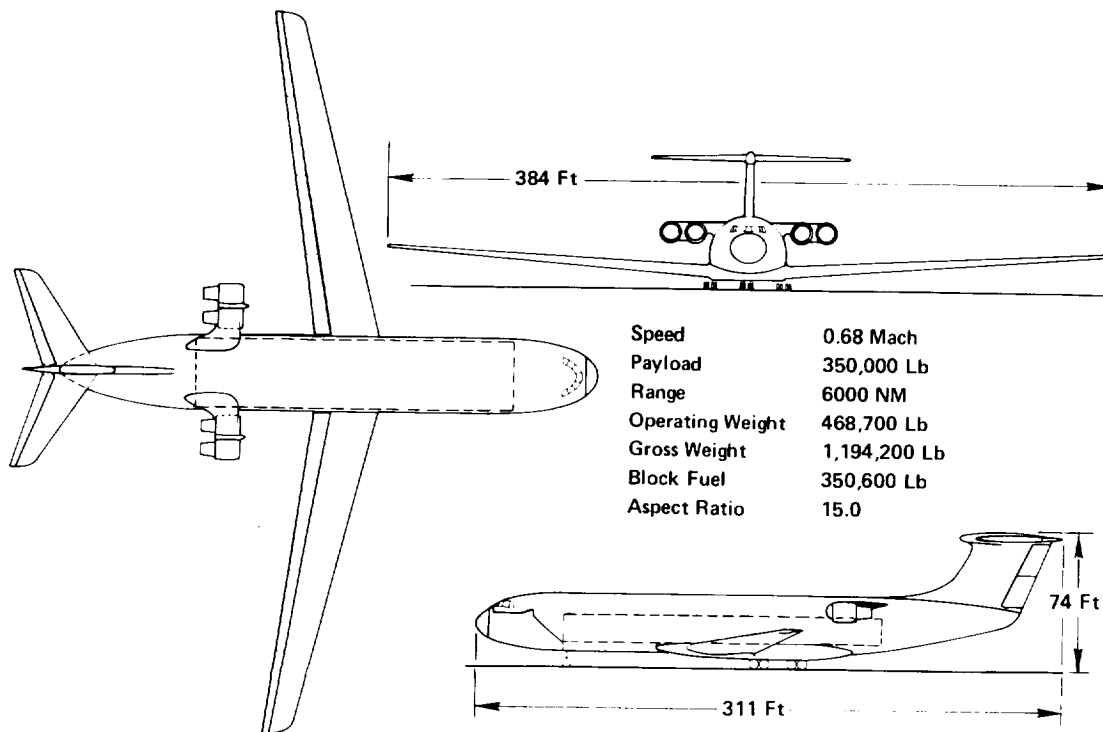

Figure 6. LFC military transport.

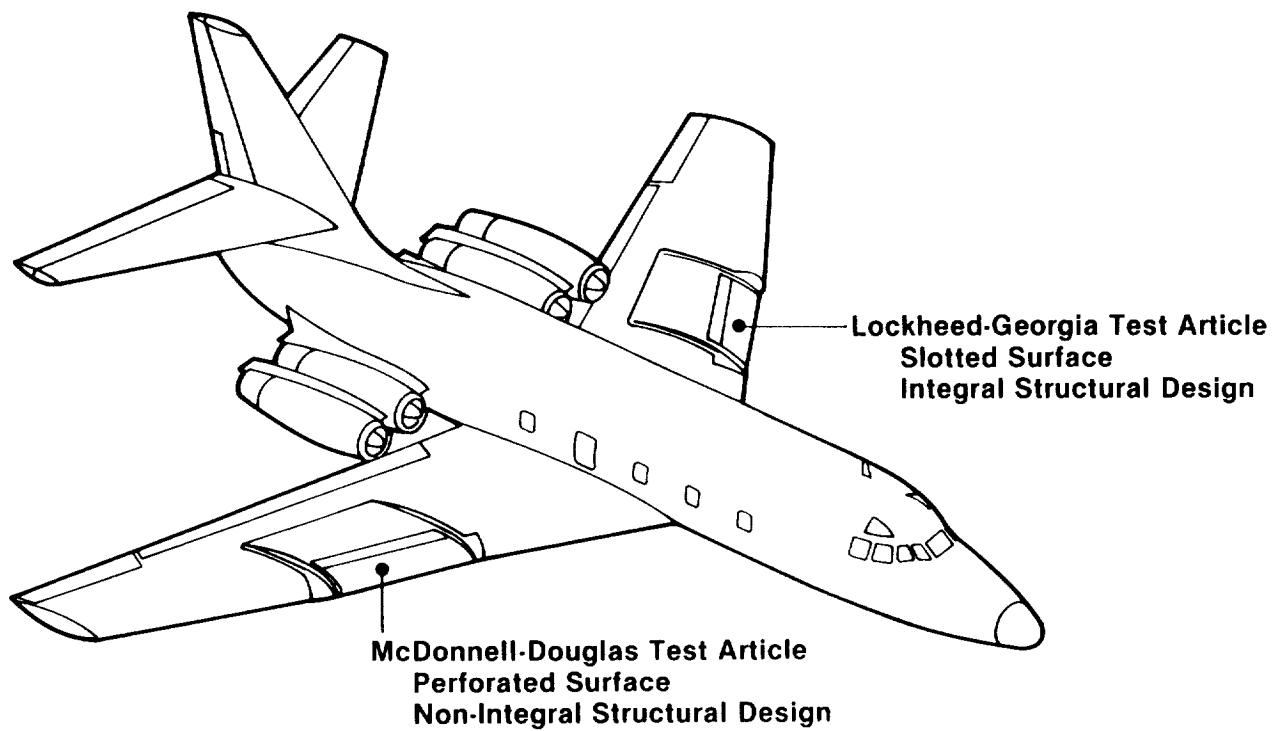

Figure 7. NASA JetStar and test articles.

- U - UPPER SURFACE DEDICATED SUCTION SLOTS
- L - LOWER SURFACE DEDICATED SUCTION SLOTS
- C - DEDICATED CLEANING/ANTI-ICING SLOTS
- D - DUAL PURPOSE SLOTS

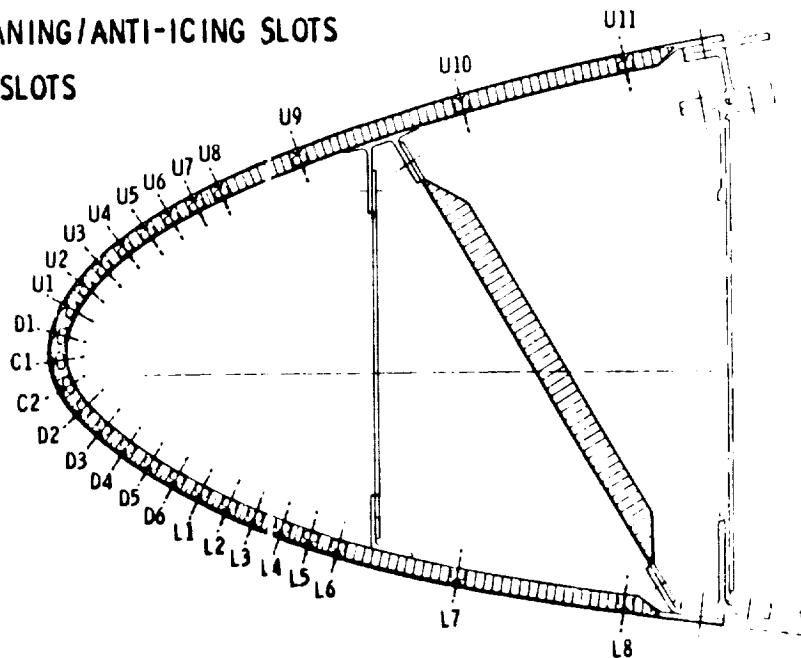

Figure 8. Slot locations on test article.



Figure 9. Photograph of Lockheed test article.

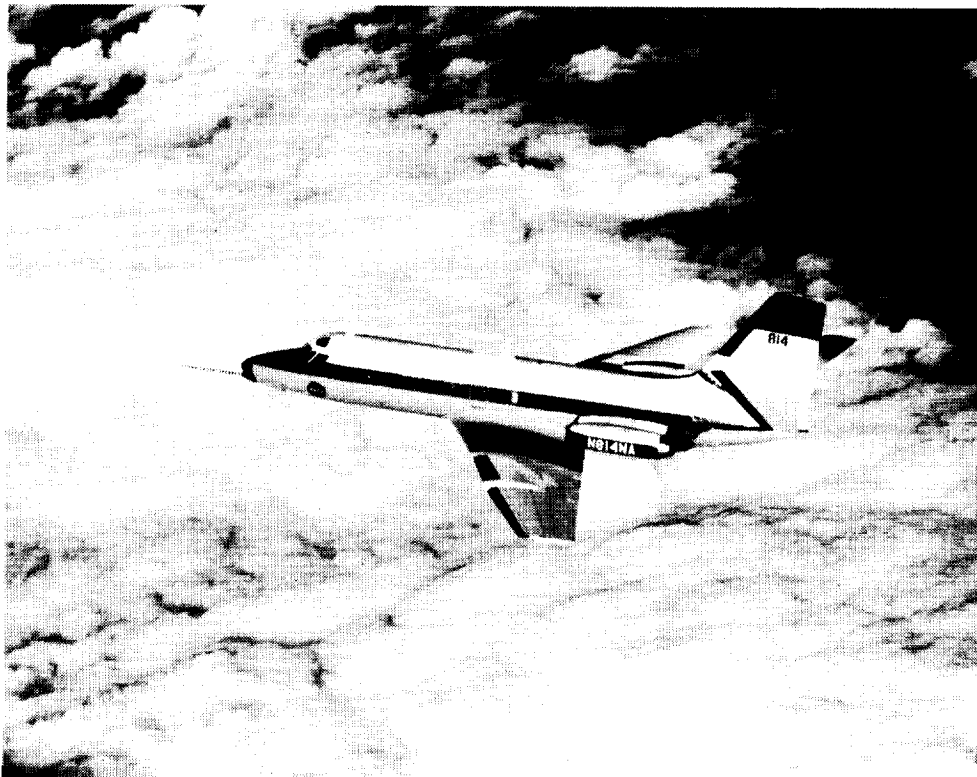

Figure 10. Photograph of NASA JetStar test aircraft.

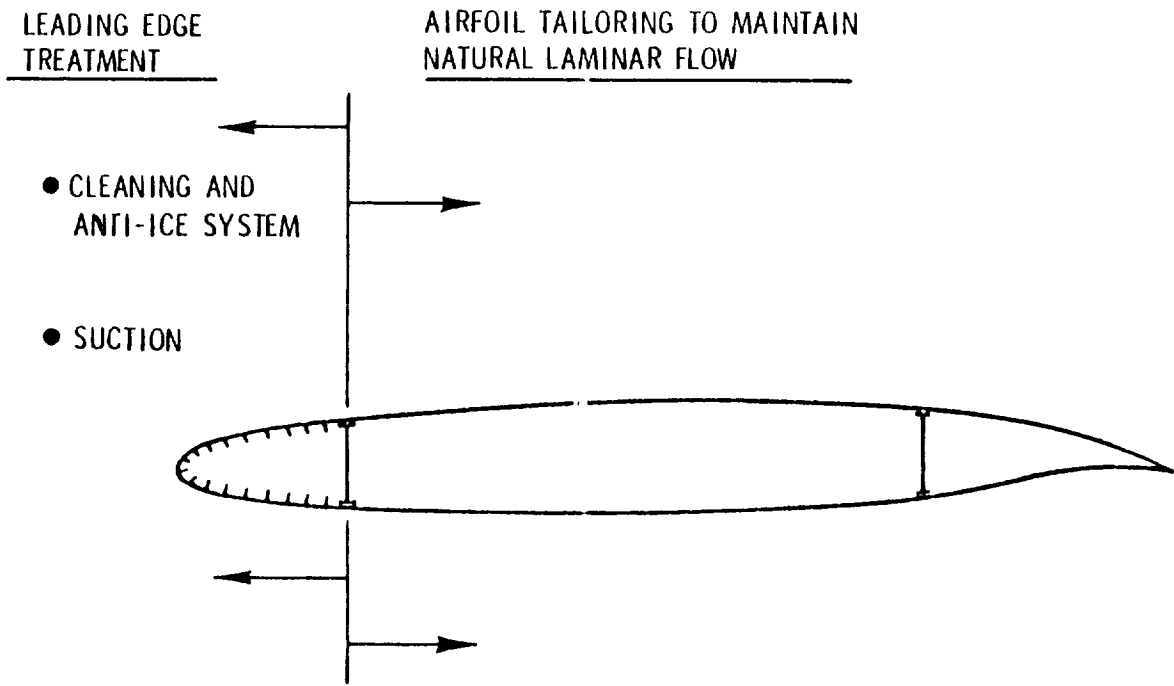

Figure 11. Schematic of hybrid laminar-flow control concept.

48 MONTH TASK-TYPE CONTRACT - NAS1-18036

	1986	1987	1988	1989	1990
TASK 1 - ALUMINUM ALLOY L.E. SLOTTED-SURFACE STRUCTURAL CONCEPT, EVAL/DEMO	[Bar spanning 1986 and 1987]				
TASK 2 - GLOBAL RANGE MILITARY TRANSPORT STUDY		[Bar spanning 1987]			
INDEPENDENT RESEARCH AND DEVELOPMENT	[Bar spanning 1986 through 1990]				

Figure 12. Laminar flow enabling technology development.

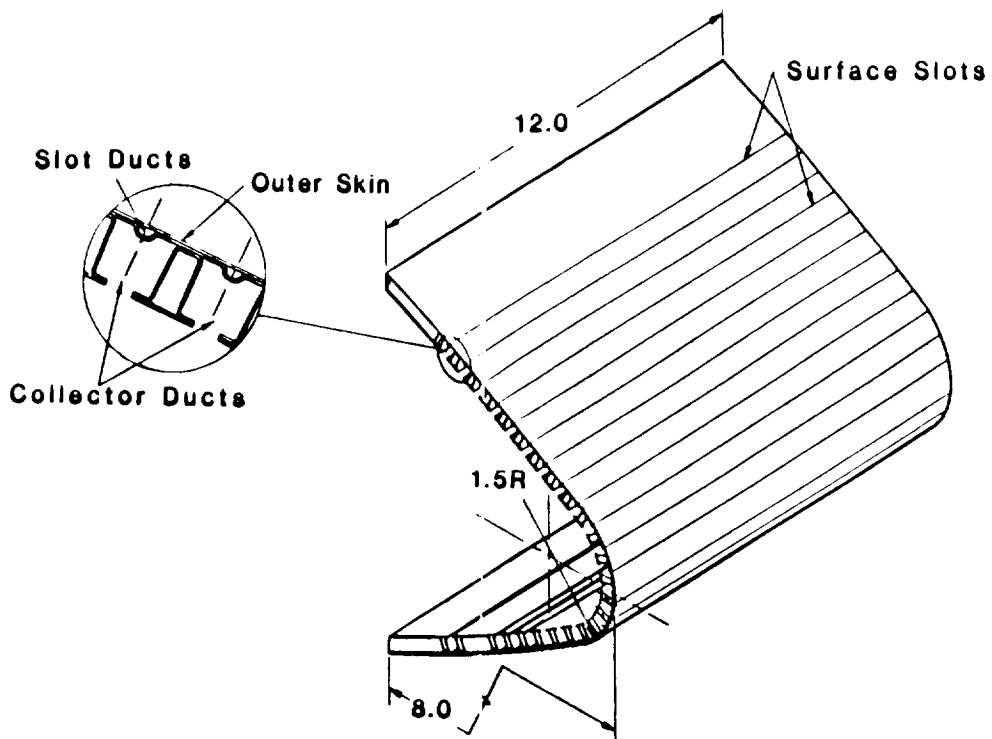

Figure 13. Leading-edge structure demonstration article.

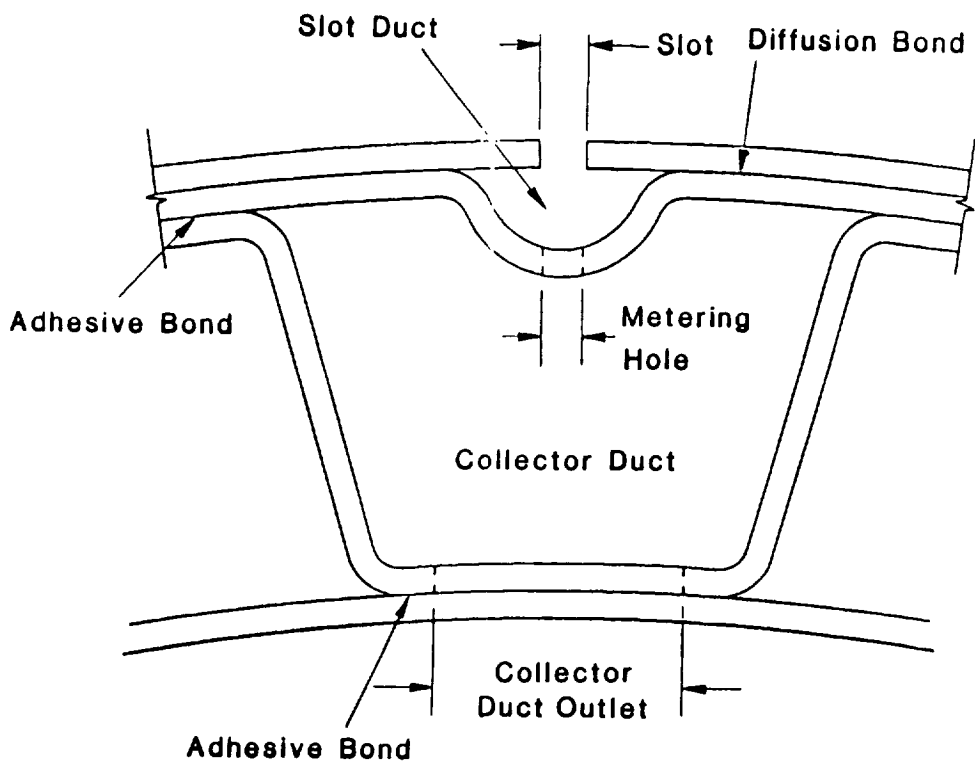
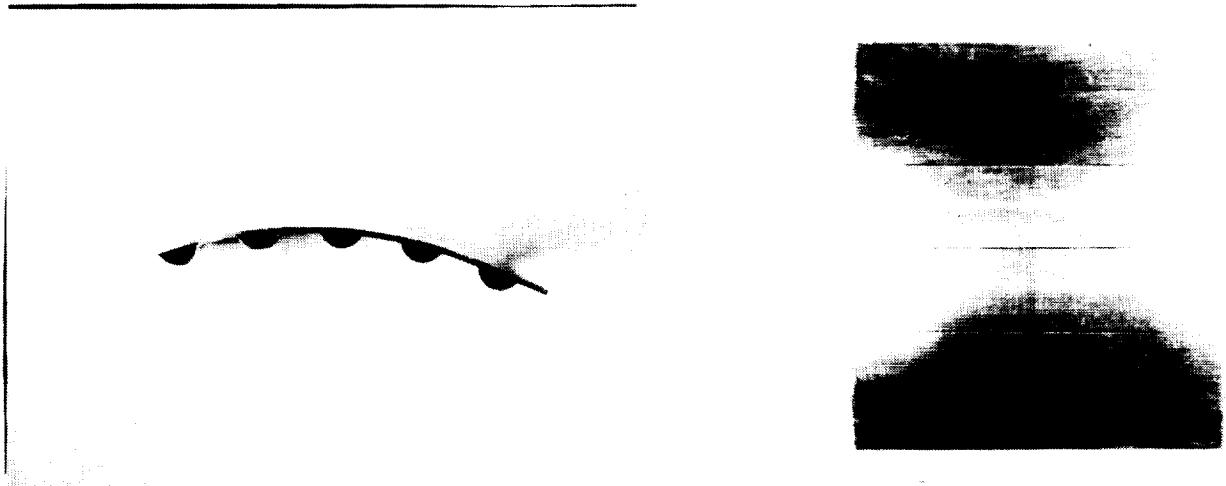

Figure 14. Leading-edge section bonding processes.



Cross-Section

Top View

Figure 15. Diffusion bonded IN9052 panel.

PS-01	INTRATHEATER VSTOL TRANSPORT AIRCRAFT
PS-03	MULTIROLE GLOBAL RANGE AIRCRAFT
PS-05	HIGH ALTITUDE, LONG ENDURANCE, UNMANNED AIRCRAFT
PS-04	SUPERSONIC VSTOL TACTICAL AIRCRAFT
PS-22	MULTIMISSION REMOTELY PILOTED VEHICLE
PS-35	AIRBORNE SURVEILLANCE SYSTEM
PS-07	SPECIAL OPERATIONS AIRCRAFT

Figure 16. Air Force Project Forecast II.

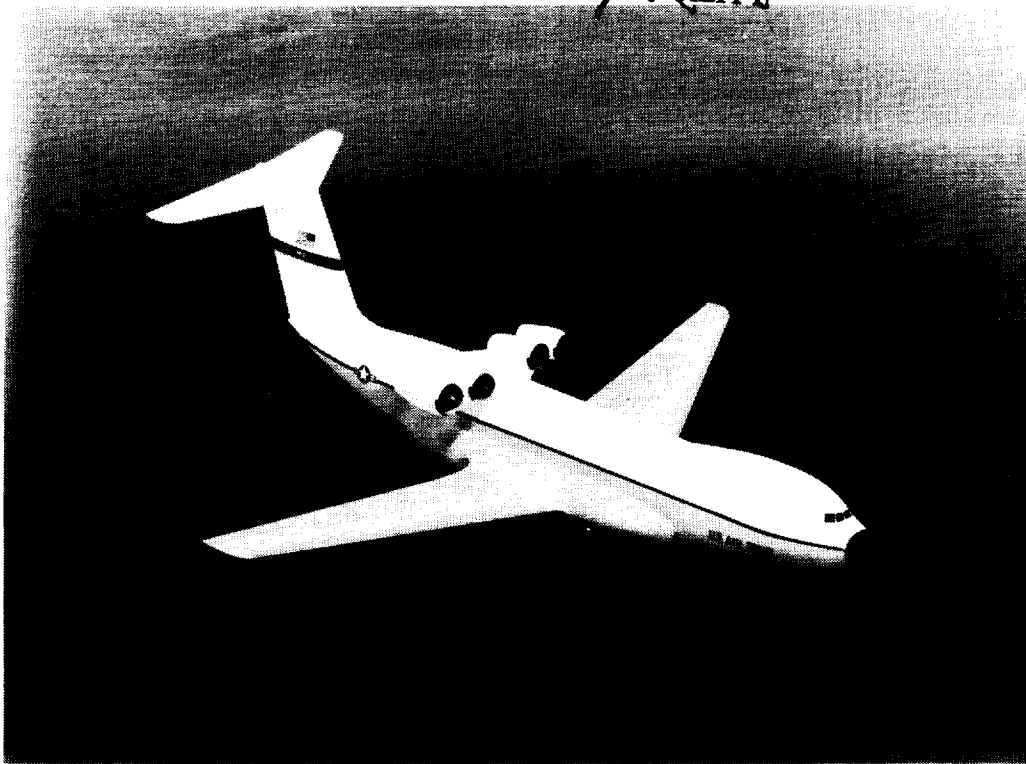

Figure 17. Military LFC transport in TAFAD study.

- PAYLOAD = 132,500 LB @ 2.5g
- CRUISE SPEED = 0.77 MACH
- INITIAL CRUISE ALTITUDE = FALLOUT VALUE
- AIRFIELD (CFL) = 10,000 FT @ S.L. STD, DAY
- FLYOUT 6,500 NM WITH FULL PAYLOAD AND RETURN
6,500 NM WITH ZERO PAYLOAD
- FIELD LENGTH @ MIDPOINT \leq 8,000 FT @ S.L. STD, DAY

Figure 18. HLFC Global Range Transport Mission characteristics.

- WING AND EMPENNAGE ACTIVE SUCTION = 15% CHORD
- WING FRONT AND REAR BEAM @ 15 AND 65% CHORD
- HLFC ACTIVATED ONLY UPON REACHING INITIAL CRUISE ALTITUDE
- TURBULENT FLOW = 6% CRUISE TIME
- 12% MINIMUM EXCESS CRUISE THRUST AVAILABLE
- WING L.E. SWEEP (DEGREES) - BAT = 25, BASIC = 20
- EMPENNAGE SURFACE SWEEP = 23 DEGREES @ 1/4 CHORD
- WING T.E. FLAPS = 25% WING CHORD
- INDEPENDENT HLFC SUCTION POWER SYSTEM
- ACCOMMODATIONS = 3 PILOTS, 1 LOADMASTER, AND TWO BUNKS

Figure 19. HLFC Global Range Transport Design ground rules.

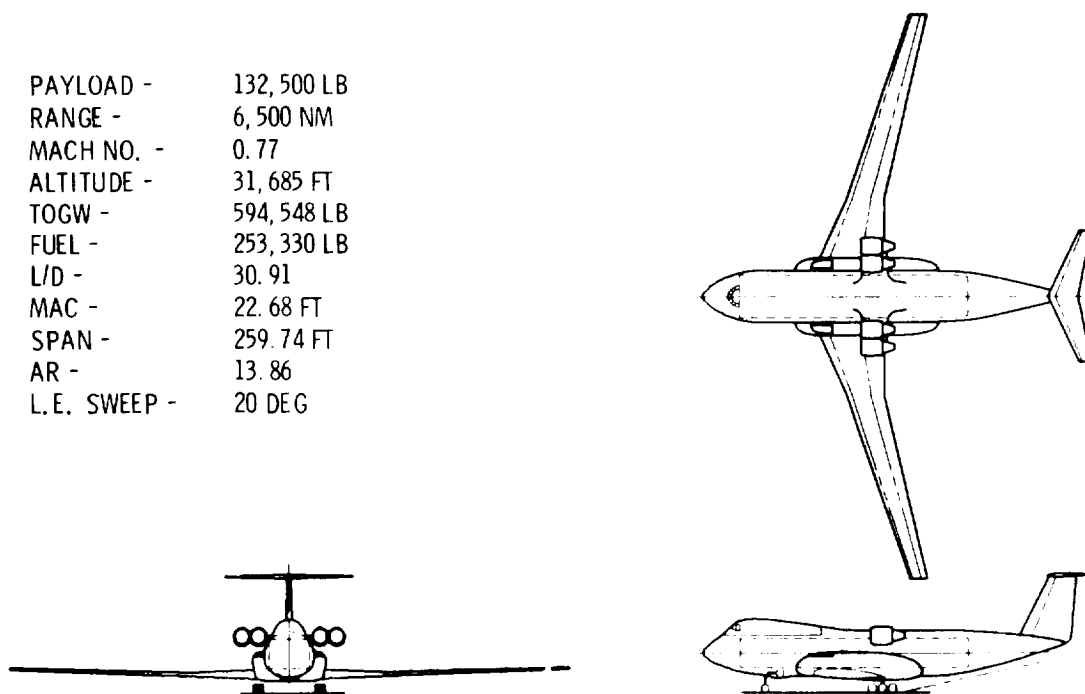

Figure 20. HLFC initial baseline design concept.

PAYLOAD - 132,500 LB
 RANGE - 6,500 NM
 MACH NO. - 0.77
 ALTITUDE - 32,119 FT
 TOGW - 616,125 LB
 FUEL - 291,401 LB
 L/D - 25.99
 MAC - 22.88 FT
 SPAN - 255.91 FT
 AR - 13.54
 C/4 SWEEP - 30 DEG

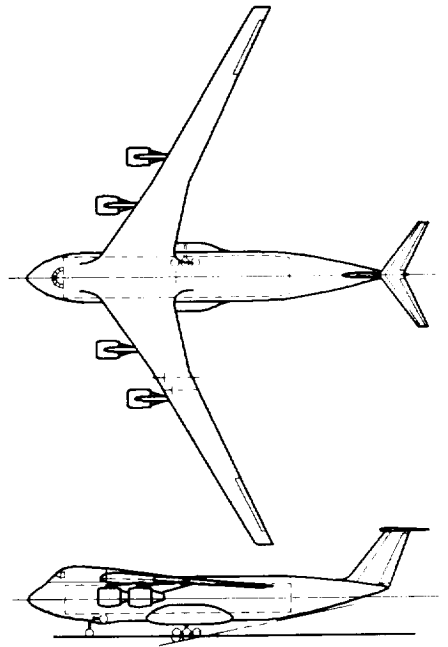
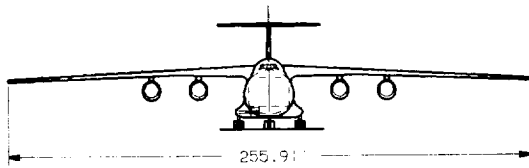

Figure 21. Turbulent flow baseline design concept.

	CHANGE %		
	HLFC BASELINE	NO HLFC ON EMP.	NO LOWER SURF. HLFC
WEIGHTS			
OPERATING EMPTY	5.4	5.4	7.9
GROSS	-4.0	-4.2	-0.6
FUEL CONSUMPTION	-13.4	-13.7	-7.9
LIFT TO DRAG RATIO	18.4	18.2	12.5

Figure 22. Benefits of HLFC.

SUBSTANTIAL PROGRESS MADE IN NASA/INDUSTRY PROGRAM OVER PAST 10 YEARS

- **CURRENT FLIGHT TESTS HAVE DEMONSTRATED SOLUTION TO LEADING EDGE CONTAMINATION PROBLEM. LAMINAR FLOW OBTAINED ON SLOTTED AND PERFORATED SURFACES**
- **\$2.28 MILLION, 4 YEAR ENABLING TECHNOLOGY DEVELOPMENT EFFORT STARTING IN LATE 1985 IS PART OF NASA R&T BASE FUNDING.**
- **A SIMPLIFIED HYBRID LFC CONCEPT PROVIDES NEAR TERM APPLICATION AND ACCELERATED EFFORT IS WARRANTED**
- **LFC DATA BASE IN WIND TUNNEL AND FLIGHT TESTS HAS BEEN LIMITED TO A MAXIMUM REYNOLDS NUMBER OF 20 MILLION**

Figure 23. Status of laminar-flow control activities.

NEED FLIGHT EXPERIMENTAL PROGRAM ON SWEEP WING AIRCRAFT WITH HYBRID LFC TO OBTAIN REQUIRED DATA AT HIGH REYNOLDS NUMBERS, 30 - 50 MILLION, REPRESENTATIVE OF TRANSPORT AIRCRAFT OPERATION

- **OBTAIN PHYSICAL FLOW PROPERTIES OF THE BOUNDARY LAYER INCLUDING L.E. CROSSFLOW AND TOLLMIEH-SCHLICHTING EFFECTS AND TRANSITION LOCATION**
- **COMPARE PHYSICAL FLOW WITH THAT PREDICTED BY TRANSONIC VISCOUS FLOW COMPUTATIONAL METHODS**
- **THESE HIGH REYNOLDS NUMBER TRANSONIC DATA CANNOT BE OBTAINED IN WIND TUNNEL TESTS**
- **NO DATA BASE OF THIS TYPE EXISTS FOR THE DESIGN OF A HYBRID LFC SYSTEM FOR TRANSPORT AIRCRAFT**
- **THIS PROGRAM CLEARLY FITS NASA ROLE IN TECHNOLOGY DEVELOPMENT FOR EMERGING TECHNOLOGIES**

Figure 24. Future development needs in hybrid LFC.

- MUST MAINTAIN OUR EDGE OVER FOREIGN COMPETITION. THIS IS BEST DONE BY THE HYBRID LFC FLIGHT EXPERIMENTAL PROGRAM
- THERE IS FOREIGN ACTIVITY UNDER WAY ON NATURAL LAMINAR FLOW BY AIRBUS, DORNIER, MBB AND ONERA
- SOME BUDGET REDUCTIONS ARE ALREADY BEING IMPOSED ON THE NASA VISCOUS DRAG REDUCTION PROGRAM.

- INDUSTRY IS NOT YET READY TO PROCEED WITH THE DESIGN AND FABRICATION OF A HYBRID LFC SYSTEM DUE TO THE LACK OF REQUIRED DATA BASE FOR TRANSPORT AIRCRAFT APPLICATION
- THE ATTAINMENT OF THE REQUIRED PHYSICAL FLOW DATA BASE IS BEST ACCOMPLISHED BY CONTINUATION OF THE CURRENT NASA/INDUSTRY LAMINAR FLOW PROGRAM

Figure 25. Concluding remarks.

