

N90-12540

VARIABLE-SWEEP TRANSITION FLIGHT EXPERIMENT (VSTFE) -
STABILITY CODE DEVELOPMENT AND CLEAN-UP GLOVE DATA ANALYSIS

R. A. Rozendaal
Boeing Commercial Airplane Company
Seattle, Washington

THE GOAL OF THE VSTFE

The Variable Sweep Transition Flight Experiment (VSTFE) was initiated in 1983 by NASA to establish an improved boundary-layer transition data base for swept wings. An earlier flight experiment using the F-111 (ref. 1) had also investigated the effect of sweep and Reynolds number on transition, but was compromised by a very limited span laminar-flow glove and a crude method for determining transition location. The VSTFE addresses these shortcomings by using natural laminar-flow (NLF) gloves which span nearly all of the variable-sweep portion of the F-14 wing and hot-film gauges to sense the state of the boundary layer.

Data from the VSTFE flight tests will be analyzed using linear stability theory to determine the growth of disturbances on the wing. The disturbance growth results from many different flight conditions will then be correlated with the transition locations measured at those conditions to form a transition criterion. This criterion will then be available for use with the linear stability theory to design laminar-flow wings for future aircraft. The establishment of a reliable transition criterion for swept wings is one of the principal goals of the VSTFE.

As part of the process of establishing a reliable transition criterion, NASA contracted with Boeing to improve and expand the capability of using linear stability theory to determine disturbance growth in typical swept wing laminar boundary layers. This paper describes some of the details of this improved stability analysis system and shows disturbance growth results for eleven cases from the VSTFE clean-up glove flight test.

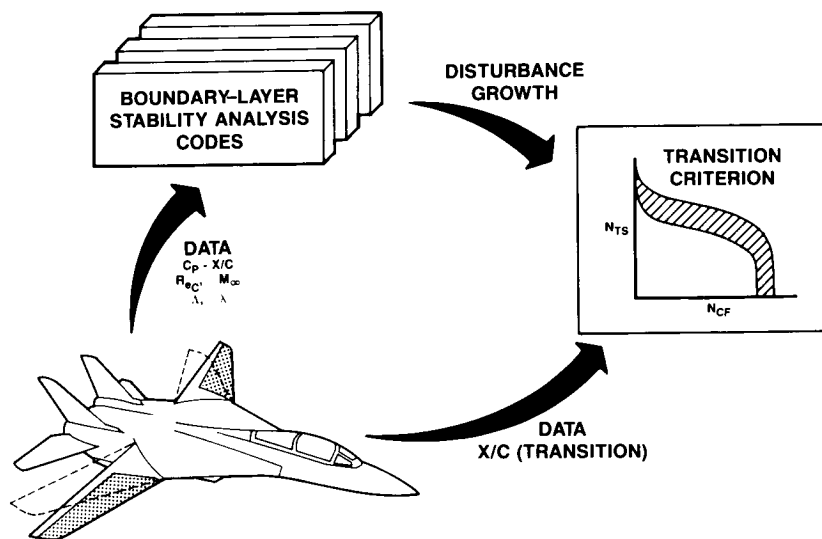

BACKGROUND ON LINEAR STABILITY THEORY

To develop an improved laminar boundary-layer stability analysis procedure, two existing computer codes were examined: COSAL, a temporal stability analysis technique using matrix solution methods (ref. 2), and MACK, a method which can solve for temporal or spatial stability using numerical integration through the boundary layer (ref. 3). After considerable work with both methods, the MACK code was chosen for use in the new stability system.

The mathematical development of the linear stability theory used in the MACK method parallels that for the Orr-Sommerfeld equation, but compressibility is included and the spanwise dimension is added. Disturbances in the boundary layer are characterized as having some wave length, λ , frequency, ω , wave direction relative to the local external flow, ψ , and a spatial growth rate, dN/ds . N is the exponent of "e" in describing disturbance growth as disturbance amplitude at some point: $= e^N$ (amplitude of that disturbance when it first starts to be amplified). The introduction of the disturbance into the compressible, 3-D boundary layer equations results in an eighth order system of equations with four unknowns: λ , ω , ψ , dN/ds . Typically, wave length or frequency and wave orientation are chosen by the user, and the other two unknowns are solved for. This is an eigenvalue problem since only certain combinations of the unknowns will solve the system. In the MACK method guesses for the eigenvalues start an iterative solution process which uses the Newton-Raphson procedure to refine the eigenvalues until the system of equations is solved to within some adequate tolerance.

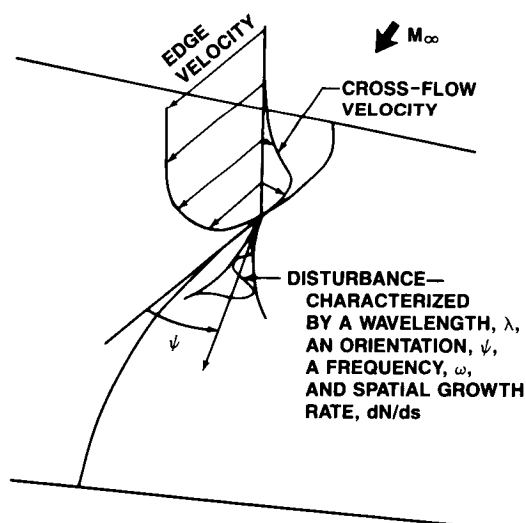

- BASIC DEVELOPMENT SIMILAR TO ORR-SOMMERFELD BUT:
- 3D BOUNDARY LAYERS CAN BE EXAMINED
- COMPRESSIBILITY INCLUDED
- INSTEAD OF FOURTH ORDER, WE GET AN EIGHTH ORDER SYSTEM OF EQUATIONS WITH FOUR UNKNOWNNS (ψ , ω , λ , dN/ds)
- TYPICALLY, WE CHOOSE TWO (ψ AND λ OR ω) AND SOLVE FOR THE OTHER TWO
- THIS IS AN EIGENVALUE PROBLEM
- SOLVED BY NUMERICAL INTEGRATION FROM OUTER FLOW TO WALL, CHANGING FREE PARAMETERS UNTIL WALL BOUNDARY CONDITIONS ARE MET

PHILOSOPHIES OF DETERMINING DISTURBANCE GROWTH

In general, the stability characteristics of a 3-D laminar boundary layer at a point on a wing involve a wide range of possible disturbance frequencies and orientations. To calculate the growth of all disturbances which may be important in causing transition, the engineer must choose some philosophy to apply in integrating the disturbance growth rate, dN/ds , with respect to distance from the attachment line.

One philosophy used presently (refs. 1 and 4) investigates two classes of disturbances, those more or less aligned with the local external flow (called Tollmien-Schlichting (TS) disturbances), and those nearly perpendicular to the local external flow (called cross-flow (CF) disturbances). This philosophy involves choosing a wave angle at which to analyze the TS disturbances. The angle is usually chosen to give the greatest growth throughout the range of important frequencies. In addition, this philosophy considers the zero frequency (stationary) cross-flow disturbances to be the most important in causing transition and calculates the growth of stationary cross-flow waves for which the component of spanwise wavelength is constant. This is the "irrotational" method described by Mack (ref. 3).

Another philosophy of calculating disturbance growth does not distinguish between TS and CF wave classes but calculates the growth of disturbances of different frequencies at whatever wave angle gives the maximum growth rate at each point on the wing.

As shown on the following figure, both philosophies just described require only a partial knowledge of the boundary-layer stability characteristics. The latest improvement to the stability analysis procedure automatically determines stability characteristics over a wide enough range of wave angles and frequencies so either of these philosophies, or perhaps a different one, can be used to calculate disturbance growth, N , from dN/ds (a function of ψ , ω) at each point on the wing. In addition, the whole procedure of calculating the boundary layer, analyzing the stability, and integrating the disturbance growth is combined into one system of programs, making better use of the analyst's time.

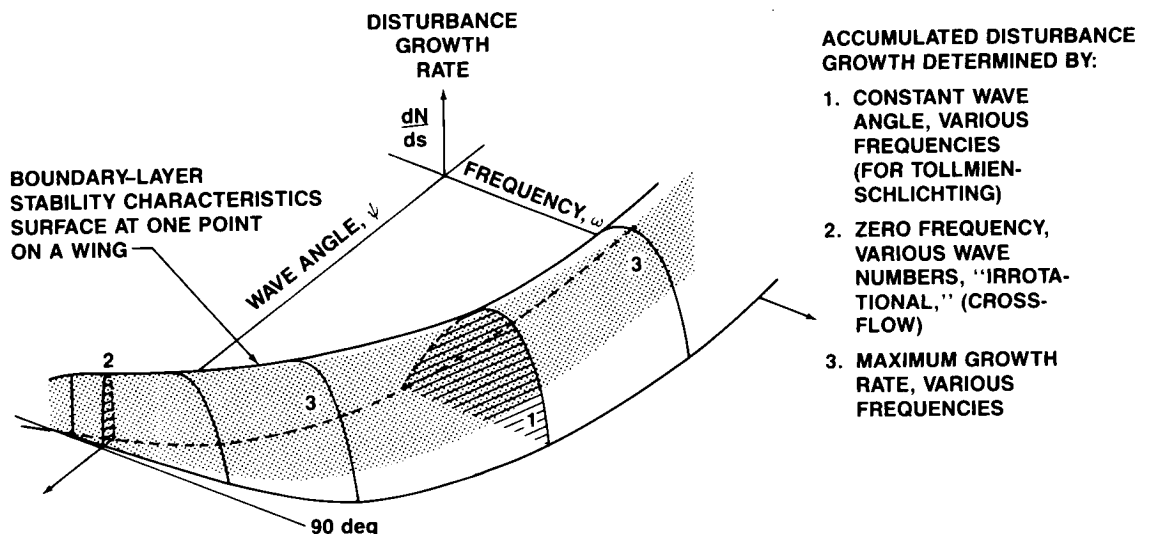

THE UNIFIED STABILITY SYSTEM

The laminar boundary-layer stability analysis procedure, as modified under the VSTFE, consists of eight computer codes and is called the Unified Stability System (USS). A master program sets up the job control statements to carry out the calculations desired by the user. Three programs set up the input for the boundary-layer analysis, carry out the analysis, and prepare the boundary-layer information for the stability codes. The boundary-layer analysis uses a finite difference method and can account for conventional or inverse taper.

Two different computer programs are used to calculate the boundary-layer stability. The solution procedure in both is almost identical, but one is tailored to analyze low wave angle disturbances, $\psi < 70$ degrees, and the other the high wave angles, $72 \leq \psi \leq 91$ degrees.

The final disturbance growth integrations (finding N from $dN/ds = f(\psi, \omega, x/c)$), are also done by two programs. One handles the TS disturbances, and the other calculates N_{CF} using the "irrotational" approach or N using the "maximum amplification" approach.

Numerous files are generated by these programs. Some only transfer information between programs, but several are available to the user for detailed examination of the boundary layer or its stability characteristics.

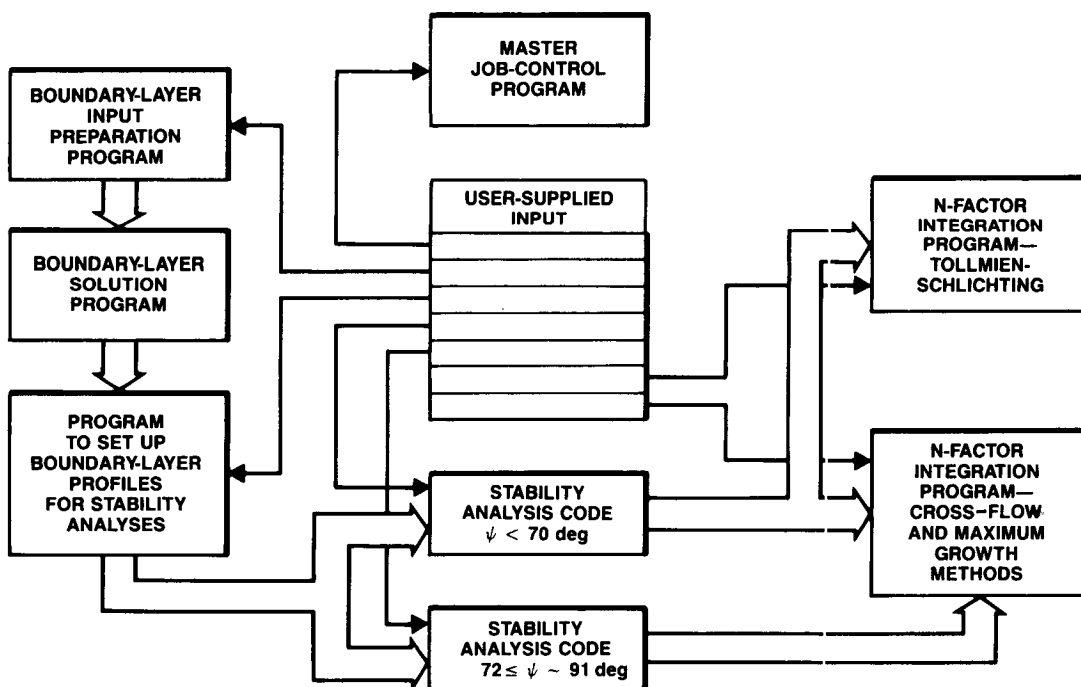

CHECK-OUT CASES FOR THE USS

The accuracy of the USS has been verified by comparing it to results of Mack (ref. 3) for two classic boundary layers: Blasius and Falkner-Skan. For both cases the boundary-layer analysis code was used to generate the boundary-layer profiles, so the check out includes the generation of the profiles, as well as the stability analyses. The Blasius boundary layer with a length Reynolds number of $(1200)^2$ was used for verification of the program which analyzes stability at lower wave angles. The graph below shows the comparison of nondimensional disturbance growth rate at two wave angles and three frequencies.

For high wave angles a Falkner-Skan profile with $\beta = 1.0$, $\theta = 45$ degrees, and length Reynolds number of 400^2 was used to verify the USS. The comparisons of neutral curve and maximum nondimensional amplification rate are shown below for wave angles from 72 to 85 degrees.

BLASIUS BOUNDARY LAYER

$$\left(\frac{U_\infty S}{\nu}\right)^{1/2} = 1200$$

FALKNER-SKAN BOUNDARY LAYER

$$\beta = 1.0, \theta = 45 \text{ deg}$$

$$R = 400$$

F ~ NONDIMENSIONAL FREQUENCY
 σ ~ NONDIMENSIONAL SPATIAL GROWTH RATE

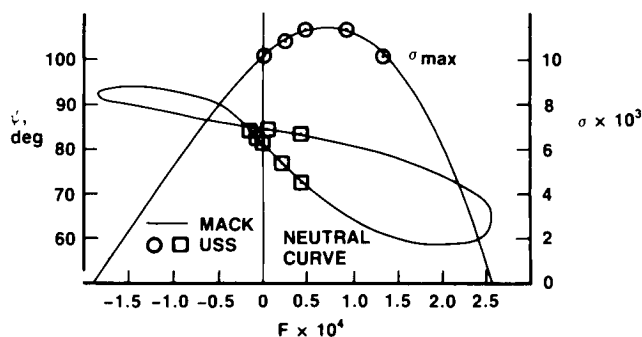
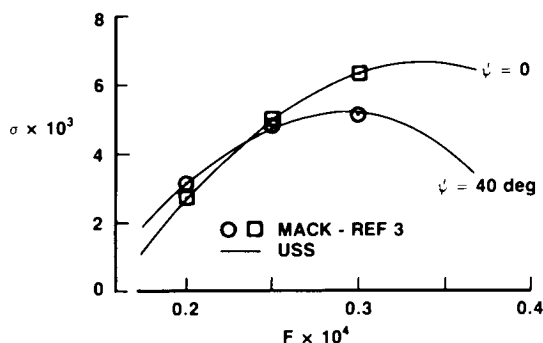

DETERMINING USS INPUT FROM THE F-14 DATA

The F-14 aircraft used for the VSTFE flight testing has three rows of static pressure orifices on the clean-up glove to measure the wing pressure field. A staggered row of hot-film gauges was placed between each of the static pressure rows to determine the boundary-layer state.

The sketch below helps show how the static pressure and hot-film data were used to determine the pressure distribution used in the stability analyses. The hot-film data showed not only the chordwise location of transition but also a spanwise location. The spanwise location was used to 1) find the local chord length used to calculate chord Reynolds number, and 2) interpolate the pressure data for determining $C_p - x/c$. Leading-edge sweep was known for each flight condition, and the three rows of pressure data were enough to get a good approximation of the isobar pattern, which determined the taper to use for the stability analyses. If too much scatter was present in the interpolated pressure distribution, a judicious hand-smoothing was done.

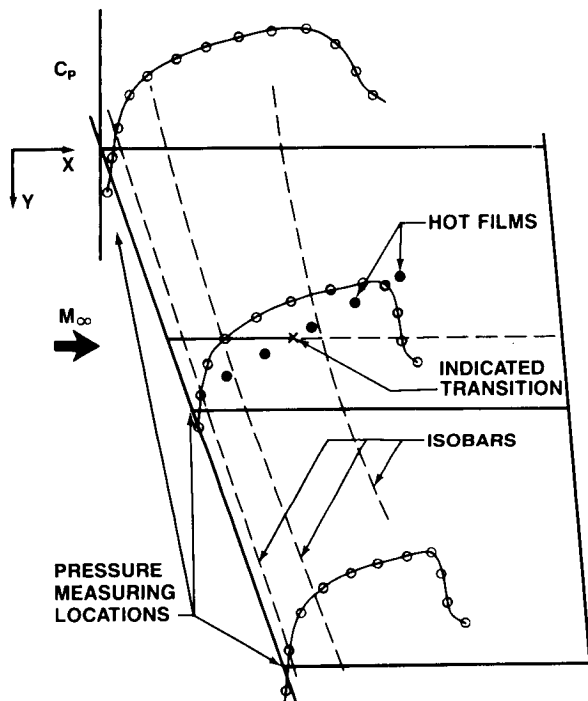

- HOT FILMS GIVE X/C AND SPANWISE LOCATION OF TRANSITION
- $C_p - X/C$ AND LOCAL CHORD LENGTH TO USE FOR BOUNDARY LAYER AND STABILITY ANALYSES COME FROM INTERPOLATION AT SPAN WHERE TRANSITION OCCURRED
- SWEEP AND TAPER ARE FROM LEADING-EDGE SWEEP AND ISOBARS

STABILITY CHARACTERISTICS FOR A TYPICAL SWEEPED WING CASE

Boundary layers on swept wings often have velocity profiles which are considerably different from the Blasius or Falkner-Skan profiles used as check-out cases for the USS. One of the cases from the VSTFE clean-up glove flight tests can be used to illustrate this. This case has a region of adverse pressure gradient near the nose followed by a second favorable gradient, and the resulting cross-flow profiles change dramatically.

As shown below, at 12.5 percent chord the boundary layer nearest the surface has responded to the adverse pressure gradient ahead of that point and switched from negative to positive cross flow. The disturbance growth characteristics show that the strong growth of cross-flow disturbances (ψ near 90 degrees), which was present near the leading edge, is largely damped at this position. A small "island" of growth is still present near 90 degrees, but the disturbances with lower wave angles have the most rapid growth at this position. This trend continues into the negative wave angle region.

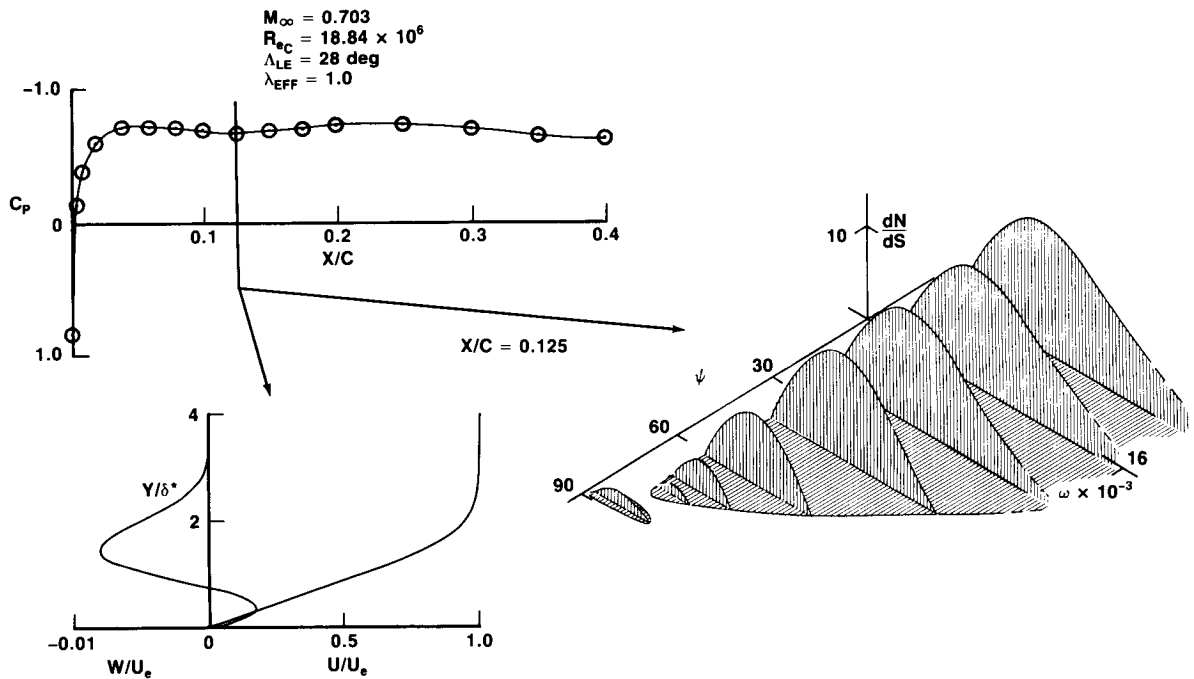

STABILITY CHARACTERISTICS FOR A TYPICAL SWEEPED WING CASE (continued)

Continuing from the previous figure, as the boundary layer moves from 12.5 to 15 percent chord, the pressure gradient has gone from adverse to favorable, and the cross flow near the surface has all returned to negative values. The stability graph shows the substantial decrease in TS disturbance growth rates at this wing station, and the cross-flow region is still mostly stable. Note, however, that there is an indication of the unstable region at wave angles higher than 90 degrees for negative frequencies. One can also consider these to be disturbances of positive frequency at wave angles near 270 (-90) degrees. This region becomes more significant for cross-flow profiles with positive components, as found in regions in which an adverse pressure gradient predominates. The USS is not presently tailored to investigate this wave angle region because in most swept wing situations presently being investigated, the disturbances with wave angles between $-50 < \psi < 91$ degrees experience the most growth, and hence, are likely to be the cause of transition.

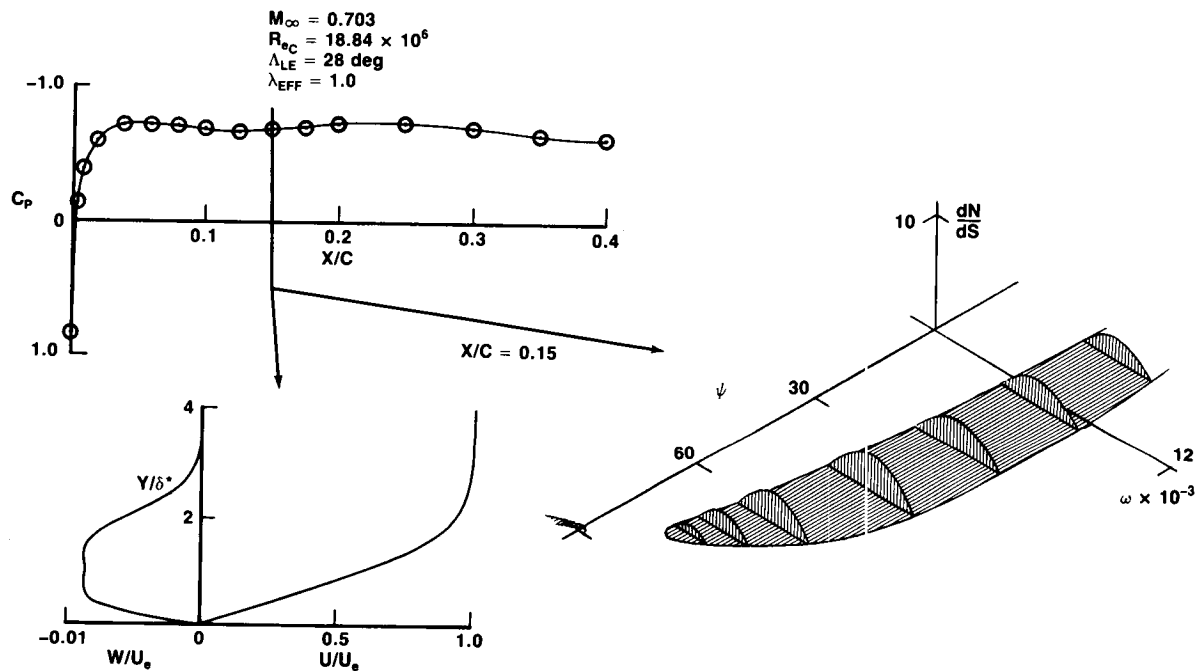

STABILITY CHARACTERISTICS FOR A TYPICAL SWEEPED WING CASE (concluded)

When the boundary layer has moved to 33.8 percent chord in our example case, it has been in the second region of adverse pressure gradient for about 8 percent chord. The velocity profile parallel to the external flow now exhibits an inflection point and is close to separation (Falkner-Skan β for this profile is very near the separation value). Most of the cross-flow velocity is now positive.

The stability characteristics show that the TS disturbances have the greatest growth rates, and this behavior extends over a frequency range large enough so the automatic frequency ranging in the USS doesn't capture the complete unstable area. At the cross-flow wave angles, the disturbance growth rate surface goes through a saddle point and starts increasing rapidly again as the $\psi > 90$, $\omega < 0$ region is entered.

For the flight condition which has just been discussed, hot-film sensors indicated a transition of the boundary layer at 30 percent chord.

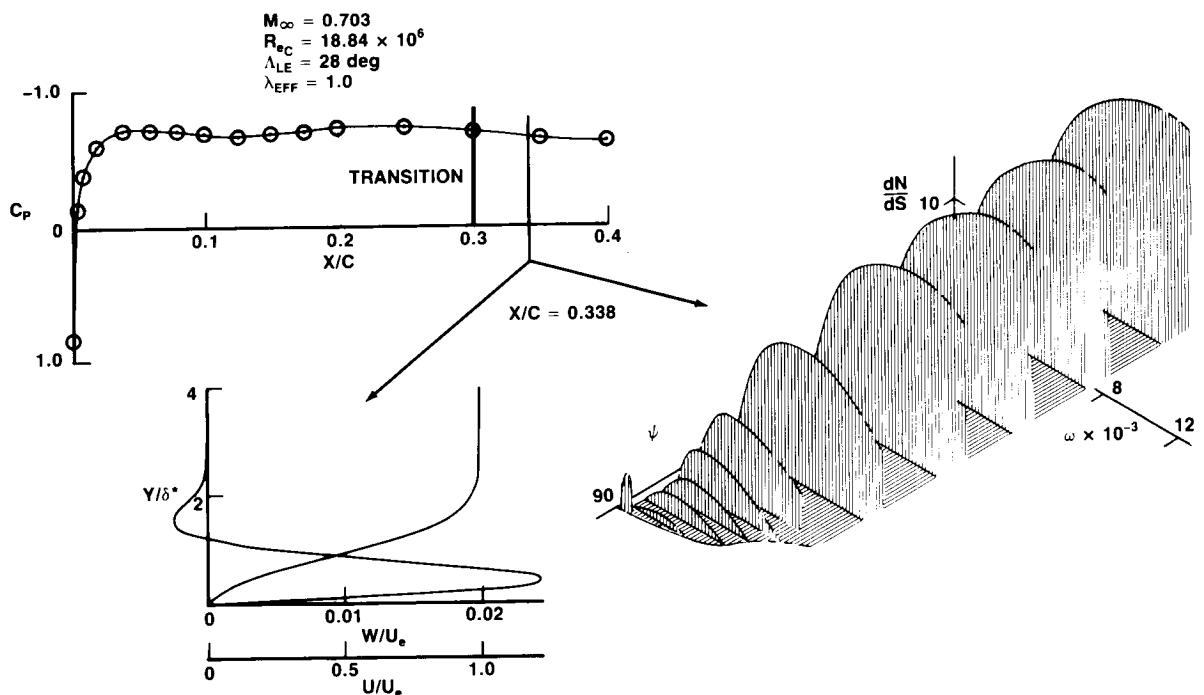

N-FACTOR GROWTH FOR THE TYPICAL SWEPT WING CASE

The N-factor growth for the case introduced in the previous figures is shown below. The maximum TS growth occurs for disturbances at 30 degrees wave angle and frequencies between about 5500 and 15000 Hertz. Maximum growth for these TS disturbances takes place where there are adverse pressure gradients.

The cross-flow N-factor envelope is formed by disturbances which have a spanwise component of wave number between 450 and 1700. In terms of wavelength these are between 0.044 and 0.167 inches. These zero-frequency, stationary disturbances show very strong damping at about 15 percent chord. Note that the cross-flow velocity profile at 15 percent chord had an unusual flat feature. Cross-flow disturbances tend to be amplified in favorable gradient regions and damped by adverse gradients, at least until the final recompression area of the wing is reached. This behavior is opposite to that of TS disturbances.

The N-factor as calculated using the wave angle for maximum amplification is also shown below. The envelope of maximum growth for this method is formed by disturbances with frequencies between about 4200 and 8000 Hertz. The wave angles which have the maximum growth rates are in the 90 degree (cross-flow) range near the leading edge but then move into the low (TS) range in the second adverse pressure gradient, eventually moving into the negative angle region (wave fronts advancing in a direction inboard of the local edge velocity).

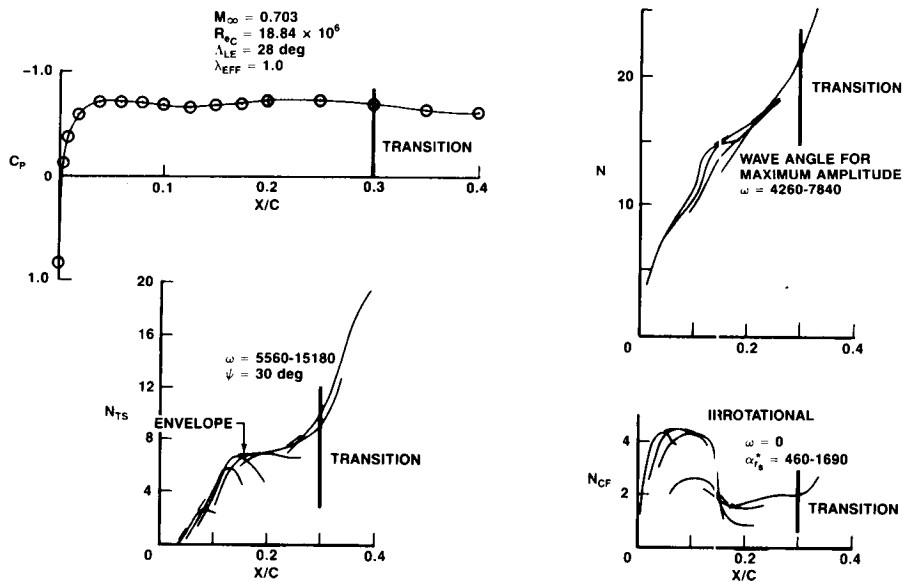

N-FACTOR GROWTH FOR A CASE WITH HIGH CROSS FLOW

Disturbance growth for another VSTFE case, one with considerably different flight conditions, is shown on this figure. For this case the cross-flow disturbances are dominant due to a strong favorable pressure gradient, even though the wing sweep is relatively low. This case illustrates a problem that can arise using a transition criterion which involves both N_{TS} and N_{CF} . In finding TS disturbance growth using a constant wave angle which gives the maximum growth, one may find that that wave angle is not in what is usually considered the TS region, but in the cross-flow region instead. This serves as a reminder that the original consideration of two classes of disturbances was just a simplification used in an attempt to predict transition in a swept wing. This problem does not negate the practice of using both TS and CF N-factors in predicting transition, but probably necessitates a change to considering the TS region to be below some wave angle, for example, between ± 50 degrees.

The disturbance growth philosophy which uses the wave angle for maximum growth likewise has weaknesses for use in defining a transition criterion. For the case shown on the previous figure the N-factor calculated by that method was near 21 at transition. Although for the present case that method predicts 16 to 19 at transition, other cases analyzed at Boeing predicted N-factors up to 30 at transition using the maximum amplification method.

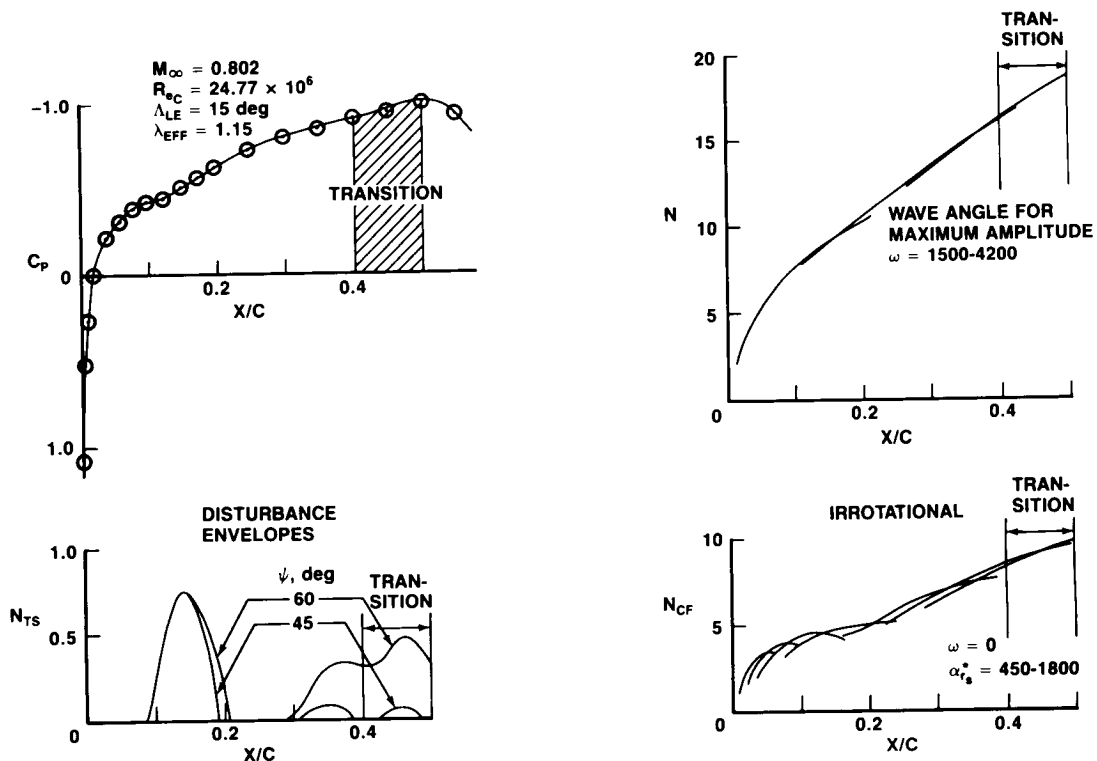

CLEAN-UP GLOVE DISTURBANCE GROWTH AT TRANSITION

Eleven cases from the VSTFE clean-up glove flight tests have calculated TS and CF disturbance growth in the area of transition plotted below. By varying flight conditions and wing sweep, the stability characteristics varied from almost exclusively CF dominant to mostly TS dominant. The traces shown below are for transition as detected by the hot-film sensors. Four of these cases had transition at one of the hot-films, so the N-factors for those cases are shown as a point rather than a line between the last laminar-indicating and the first turbulent-indicating hot-film. The length of the lines represents the N-factor change in 10 percent chord.

Despite the use of improved transition sensing methods, the disturbance growth traces from the VSTFE clean-up glove flight tests give a much broader $N_{CF} - N_{TS}$ region at transition than the F-111 data. Several factors could be involved in this scatter: 1) Data from both tests involve uncertainties, not all of which are well understood, 2) The F-111 data may result in a generally pessimistic TS N-factor at transition, and 3) The use of the $N_{CF} - N_{TS}$ graph may not collapse the transition points to a narrow band. A careful review of the clean-up glove data will show which cases have data with the least uncertainty. When analyzed, these may show less scatter.

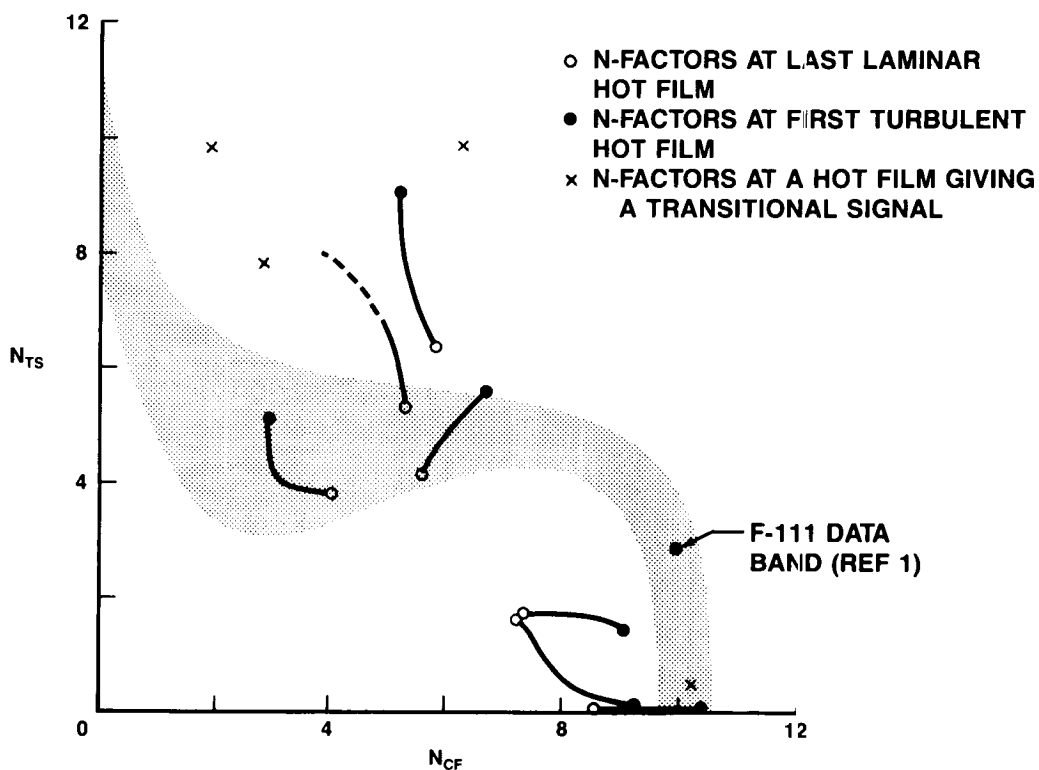

CONCLUSIONS FROM THE VSTFE CLEAN-UP GLOVE ANALYSES AND RECOMMENDATIONS

The primary goal of the VSTFE is to establish an improved swept wing transition criterion. The development of the Unified Stability System gives the aerodynamicist a way of quickly examining disturbance growth for a wide variety of laminar boundary layers, but the philosophy to be used in relating disturbance growth to transition and the accuracy of the data to use in the correlation are problems requiring more work.

The disturbance growth traces shown on the previous graph are too scattered to define a transition criteria to replace the F-111 data band, which has been used successfully by Boeing to design NLF gloves. Still, a careful review of the clean-up glove data may yield cases for which the transition location is known more accurately. Liquid crystal photographs of the clean-up glove show much spanwise variation in the transition front for some conditions, and this further complicates the analyses. Several high quality cases are needed in which the transition front is well defined and at a relatively constant chordwise station. Before liquid crystal coatings can be used to establish this information, it must be verified that they do not affect transition themselves.

The question of how best to correlate disturbance growth with transition location should not be addressed until high quality transition data are available. Since one glove remains to be tested in the VSTFE, this program can still meet its goals.

CONCLUSIONS

- VSTFE CLEANUP GLOVE EXHIBITED GROWTH OF DISTURBANCES OF WIDELY VARYING CHARACTERISTICS
- TRANSITION LOCATION NOT LOCATED ACCURATELY ENOUGH ON CLEANUP GLOVE FLIGHTS
- USE OF THE USS CAN GIVE RAPID INSIGHT TO QUITE COMPLEX STABILITY CHARACTERISTICS
- DISTURBANCE GROWTH PHILOSOPHIES PRESENTLY USED DON'T RESULT IN A SATISFYING TRANSITION CRITERION

RECOMMENDATIONS

- REVIEW CLEANUP GLOVE DATA FOR CASES WHERE TRANSITION WAS ACCURATELY KNOWN; ANALYZE THESE CASES
- CONDUCT TESTS ON THE NEXT VSTFE GLOVE WITH IMPROVED TRANSITION SENSING, WHICH GIVES GOOD CHORDWISE AND SPANWISE RESOLUTION

REFERENCES

1. Runyan, L. James; Navran, Brent H.; and Rozendaal, Rodger A.: F-111 Natural Laminar Flow Glove Flight Test Data Analysis and Boundary Layer Stability Analysis. NASA CR-166051, 1984.
2. Malik, M. R.; and Orszag, S. A.: Efficient Computation of the Stability of Three-Dimensional Compressible Boundary Layers. AIAA Paper 81-1277, 1981.
3. Mack, Leslie M.: Boundary-Layer Linear Stability Theory. AGARD Report No. 709, 1984.
4. Rozendaal, Rodger A.: Variable Sweep Transition Flight Experiment (VSTFE) - Parametric Pressure Distribution Boundary Layer Stability Study and Wing Glove Design Task. NASA CR-3992, 1986.