

NASA Technical Memorandum 102405

A New Test Machine for Measuring Friction and Wear in Controlled Atmospheres to 1200 °C

Harold E. Sliney and Christopher DellaCorte
Lewis Research Center
Cleveland, Ohio

Prepared for the
Annual Meeting of the Society of Tribologists and Lubrication Engineers
Denver, Colorado, May 7-11, 1990

NASA

(NASA-TM-102405) A NEW TEST MACHINE FOR
MEASURING FRICTION AND WEAR IN CONTROLLED
ATMOSPHERES TO 1200 C (NASA) 23 p CSCL 11D

N90-12670

Unclass
0243253

G3/24



A NEW TEST MACHINE FOR MEASURING FRICTION AND WEAR IN CONTROLLED
ATMOSPHERES TO 1200 °C

Harold E. Sliney and Christopher DellaCorte
National Aeronautics and Space Administration
Lewis Research Center
Cleveland, Ohio 44135

SUMMARY

This paper describes a new high temperature friction and wear test apparatus (tribometer) at NASA Lewis Research Center, Cleveland, Ohio. The tribometer can be used as a pin-on-disk or pin-on-ring configuration and is specially designed to measure the tribological properties of ceramics and high temperature metallic alloys from room temperature to 1200 °C. Sliding mode can be selected to be either unidirectional at velocities up to 22 m/sec or oscillating at frequencies up to 4.5 Hz and amplitudes up to $\pm 60^\circ$. The test atmosphere is established by a controlled flow rate of a purge gas. All components within the test chamber are compatible with oxidizing, inert, or reducing gases.

INTRODUCTION

The objective of this paper is to describe a new high temperature tribometer located at NASA Lewis Research Center in Cleveland, Ohio. The motivation for the design and fabrication of this machine was to achieve the capability to determine the friction and wear of ceramic and other high temperature materials in an atmosphere and under sliding conditions relevant to high temperature aerospace and terrestrial applications.

Monolithic ceramics and ceramic matrix composites and coatings are candidate materials for tribological applications in hypersonic aircraft such as the National Aerospace Plane (NASP),¹ Stirling Space-Power Engine (SSE),² and Department of Energy (DOE) sponsored energy efficient engine programs.³

In addition, there are numerous less spectacular current and near term applications for improved high temperature tribological materials in aeronautics and in general industry.

High temperature tribometers have been used for many years at our Center (see for example, Ref. 4). Others are described in Ref. 5. However, none of these have as many capabilities for tribologically testing ceramics and metals as the new tribometer.

The primary purpose of this paper is to describe the tribometer including the computer data acquisition system. Some representative friction and wear data are included by way of example.

DESIGN REQUIREMENT

The design specifications called for the following general capabilities.

- Continuous unidirectional rotation over a large range of sliding velocities to simulate shaft bearing and seal sliding motion.
- Oscillating over a range of frequencies and amplitudes simulative of bearings and seals in reciprocating machinery, e.g., Diesel piston/cylinder contacts.
- High temperature capability
- Atmosphere control: Controlled humidity, air, inert gases, hydrogen.
- Specimen geometry: provisions for various contact configurations.

A machine meeting these requirements was designed and fabricated at Mechanical Technology, Inc., Latham, New York under NASA/DOE Contract DEN3-362. The resulting tribometer has the following capabilities:

Specimen Configuration:

- (1) Pin-on-disk (axial loading parallel to drive spindle).
- (2) Pin or rub shoe on ring (radial loading perpendicular to drive spindle).

- Sliding velocity (Rotation): 0.2 to 22 m/sec (75 to 8250 rpm on a 0.05 m diameter wear track.
- Oscillating conditions: 0.06 to 4.6 cps, 0 to $\pm 60^\circ$ amplitude.
- Specimen temperature: ambient to 1200 °C
- Atmosphere: Purge gas atmosphere at slightly over 1 bar pressure of controlled humidity air, inert gas or hydrogen.
- Specimen load: 1 to 90 N radial, 1 to 900 N axial.

DESCRIPTION OF TRIBOMETER

An isometric layout of the tribometer is shown in Fig. 1. The machine consists of a drive system, a support bearing spindle, and a resistance heated furnace that is the specimen test chamber.

All hot section components with the exception of the silicon carbide heat shield and the shaft ring seal were initially made of partially stabilized zirconia (PSZ). The PSZ parts had adequate durability for repeated tests at specimen temperatures up to about 900 °C. However, cracks developed in all of the PSZ parts after 10 or more tests at 1100 to 1200 °C leading to fracture of the parts. It was subsequently learned from the manufacturer that the type of PSZ used (9 mole percent MgO stabilized PSZ) can undergo significant microstructural changes from heating at temperatures above 1000 °C. Minimal microstructural changes are observed after heating for 2000 hr at 900 °C. Therefore, the manufacturer does not recommend the use of this material above 800 °C where very long life stability is required.

The failed parts were replaced by Inconel 718 parts with 0.4 mm thick thermal barrier coatings (TBC) of PSZ. The PSZ coated parts are workable, but have to be recoated periodically because the coatings eventually spall and must be reapplied. It is expected that a more permanent solution will be the

replacement of monolithic PSZ parts with a composite ceramic such as SiC-reinforced alumina which is known to have superior strength and fracture toughness.

Descriptions of the various systems making up the tribometer as originally equipped with PSZ hot section components are given below.

Motor Drive System

The unidirectional and oscillating specimen drive systems are shown schematically in Fig. 2. For unidirectional rotation, the specimen is driven by a variable speed dc motor connected to the drive spindle by a toothed belt and a 3:1 pulley speed increaser drive capable of providing sliding velocities from 0.2 m/sec at 75 rpm to 22 m/sec at 8250 rpm. Motor speed is regulated by a digital controller.

For oscillating motion, the pulley and belt system is replaced by a gear reducer and crank mechanism. The motor speed is first reduced by a 10:1 gear box which drives a crank mechanism that gives an oscillating output from 0 to $\pm 40^\circ$, a second gear box that can provide either a 1.5 to 1 reduction to give 0 to $\pm 30^\circ$ oscillation or a 1 to 1.5 increase to give $\pm 30^\circ$ to $\pm 60^\circ$ oscillation. Therefore, this system can provide any angle of oscillation from 0 to $\pm 60^\circ$. The frequency range is 0.06 to 4.6 Hz.

Spindle Design

Details of the support bearing spindle are illustrated with a cutaway drawing in Fig. 3. A tie bolt extends through the entire length of the hollow drive shaft. The tie bolt and the drive shaft each consist of a hot section of PSZ or alternative high temperature material and a cold section of 17-4PH steel. The ceramic to metal transition for the tie bar is made with a 17-4PH sleeve that is shrink-fitted over the ceramic at one end and screwed to the metal section at the other end. The tie bar firmly clamps the test disk and

also clamps the two shaft sections together. The clamping force on the disk and on the shaft sections is provided via the tie bar by means of a compressed spring at the cold end of the drive shaft.

The spring is not fully compressed during assembly. This provides for a reasonably constant clamping force in spite of differential thermal expansion and compression of the shaft assembly during heating and cooling. Also, by applying the clamping force with a spring at the cold end of the spindle shaft assembly, the disk and shaft sections can be precisely located without the use of screw threads in the hot zone. This eliminates stress concentrations associated with screw threads in tension and also facilitates disassembly because there are no screw threads to gall or seize after being exposed to high temperature.

The other ceramic parts associated with the bearings spindle are a nosepiece heat shield and the shaft ring seal which are made of silicon carbide.

The shaft is supported by two angular contact ball bearings that are lubricated with recirculating oil. A water cooling jacket is provided at the end of the spindle adjacent to the furnace. Figure 4 gives the calculated temperature distribution in the bearing spindle when the wear disk specimen is 1091 °C (≈2000 °F). The example given is for a spindle equipped with PSZ shaft and tie bar hot sections. The shaft temperature rapidly drops from 1040 °C in the furnace to 180 °C at the PSZ to 17-4PH junction. The tie rod temperature is 172 °C at its PSZ to 17-4 PH junction. The SiC shaft ring seal is 359 °C and the labyrinth shaft seal, which is enclosed in a water-cooled jacket is 49 °C. The temperature of the front bearing for this case is 82 °C. Clearly the metal parts are exposed to very moderate temperatures although they are only a short distance away from the furnace hot zone. This is achieved by: (1) thick thermal insulation in the furnace; (2) the use of low thermal

conductivity material for the shaft and tie rod hot end; (3) strategic placement of a SiC nosepiece heat shield behind the wear disk; and, by (4) water jacketing the front section of the bearing spindle around the labyrinth shaft seal.

Furnace

The furnace is a split design to allow assembly and disassembly. It consists of a stainless steel outer shell that is heavily lined with layered, soft, fibrous zirconia insulation. (The layering is not shown in Fig. 1.) The layered approach is used to allow easy replacement of the innermost layers in the event of contamination.

The furnace is equipped with platinum-rhodium thermocouples placed in close proximity to the pin and disk tribo-specimens. The furnace also has pyrometer ports with calcium fluoride windows for high infrared transmissibility. Heating is provided by six 700-W silicon carbide resistance heating elements arranged concentrically around the wear disk specimen. Temperature is controlled by a programmable controller.

Tribospecimens

The wear pin and disk specimens are shown in Figs. 5(a) and (b). The pins are hemispherically-tipped cylinders that are 28 mm long with a cylindrical diameter of 9.52 mm and hemispherical radii of either 4.76 or 25.4 mm. The disks are 63.5 mm in diameter and 12.7 mm thick with a nominal 15.9 mm mounting hole in the center. The precise hole size depends on the thermal expansion coefficient of the disk material. Adequate clearance must be allowed for differential expansion of the shaft and the disk materials. An isometric schematic of the pin-on-disk contact configuration is shown in Fig. 4(c). During disk rotation the pin slides on a 50.8 mm diameter wear track on the disk.

Load and Friction Force Measurement

The load and friction force measuring systems are part of the tribometer isometric drawing in Fig. 1 and are also shown in Fig. 5(c). The arrangement shown in Fig. 1 is used for axial loading of the pin on the disk. The layout for radial loading of a pin or rub shoe on the rim of the disk is not shown, but it is accomplished by repositioning the supporting fixture for the loader assembly and the torque tube assembly by 90°. In this mode, the loader arm is installed in the tube labeled "pyrometer port" in Fig. 1. The tube in which the loader assembly was installed for axial loading then is used as the pyrometer port for the radial load arrangement. The remaining realignments are accomplished with the micrometer positioning stages on the supporting fixture.

For loads greater than 10 N, load is applied by a pneumatic actuator with accurate pressure regulation. (For normal loads of less than 10 N, the pneumatic regulator is replaced by a mechanical, dead weight load system.) The load is transmitted by a horizontal linkage consisting of a flexure, a load cell for continuous measurement of the normal load, and a ceramic push rod, that transmits the load to the pin. The weight of this assembly is supported by a linear ball bushing (not shown in the drawing) just ahead of the actuator to eliminate radial or overhung loading on the actuator bushing and seal. The pin is clamped in a vertical ceramic torque tube at a right angle junction with the load rod. A push rod in the hollow torque tube clamps the pin with a force applied by a spring pack located near the bottom of the torque tube. The torque tube is mounted to a load cell for continuous measurement of the friction force and then to a flexure. Alignments of the load linkage and the torque tube are made with vertical and horizontal micrometer-positioning stages.

The purpose of the flexure in the load linkage is to allow the small displacement needed to actuate the friction measuring load cell. The deflection amplitude is trivial and does not introduce a measurable error in the friction force measurements. The purpose of the flexure in the torque arm is to allow the pin specimen to move axially as wear occurs. The bending load required for small deflections subtracts only 0.06 N/mm of axial pin displacement from the normal load applied by the actuator. Figure 6 presents curves of axial pin displacement as a function of wear scar diameter for hemispherical radii of 4.76 and 25.4 mm. These curves were calculated from Eq. 2 in the Appendix of this paper. Both curves are extended to a limiting wear scar diameter which is equal to the wear pin cylindrical diameter of 9.52 mm. This represents the maximum wear of the hemispherical segment at the tip of the pin. In our experiments, the wear scar diameters seldom exceed 6 mm. This corresponds to an axial displacement of about 1 mm for the 4.76 mm hemisphere and about 0.2 mm for the 25.4 mm hemisphere. These in turn, introduce errors of only 0.06 and 0.012 N subtracted from the normal load due to deflection of the flexure. Even allowing for a small additional displacement due to disk wear the measurement errors due to flexure bending are a maximum of only about 1 percent when a 10 N normal load is used and therefore no correction is considered to be necessary.

Atmosphere Control

For atmosphere control, gases can be introduced at low pressures into the furnace chamber via a gas inlet port. Flow is maintained by leakage past the shaft seal to the outside atmosphere. Leakage to the drive spindle is prevented by the labyrinth seal shown in Fig. 3 and by a seal buffer gas. Exhaust gas is removed by an exhaust hood directly above the tribometer.

Computer Data Acquisition System

The tribological data from the tribometer is monitored, manipulated and stored by a computerized data acquisition system that is described in detail in Ref. 7. The system is based upon a personal computer interfaced to the rig instrumentation by an analog to digital converter. In general, analog voltage signals from the test rig are converted into computer compatible digital signals from the A to D converter. The computer, driven by dedicated software, displays, manipulates, and stores the data in a meaningful format. Two computer programs drive the data acquisition system. One program is suitable for unidirectional sliding where the friction signal is fairly constant. The other program is designed for an oscillating motion test where the friction force resembles a square wave. The main difference between the two programs is that for unidirectional motion, the computer samples the data at certain timed intervals and for oscillating motion tests, data acquisition is triggered by a cam operated switch on the drive spindle.

The data can be transferred to spreadsheet format programs for further manipulation and graphing. Thus, with this data acquisition system, the data is recorded, manipulated, stored and plotted or graphed.

Example of Test Data

Figures 8(a) and (b) are examples of data acquired and printed by the computerized data acquisition system. Friction coefficient is continuously computed from the ratio of friction force to the normal load as measured by the sensors in the load and torque linkages. The normal load during the test is also shown. The friction specimens in these experiments were aluminum oxide containing 25 vol % silicon carbide whiskers. The data indicate a relatively steady, but very high friction coefficient of about 0.75 at 24 °C and somewhat lower, but very erratic friction coefficient at 800 °C.

SUMMARY REMARKS

- This paper describes a new tribometer designed primarily to measure the friction and wear of ceramics or metals at high temperature.
- The machine has performed satisfactorily in unidirectional rotation and oscillating modes from 25 °C to 1200 °C.
- A computerized data acquisition system continuously monitors temperatures, friction force, normal load, shaft speed, and test machine parameters.
- PSZ hot section parts in the tribometer were durable for all hot section parts at temperatures up to 800 °C. They were useful for a limited number of experiments to 1200 °C, but other high temperature materials are needed for long life parts that are to be used above 800 °C.

APPENDIX

Pin wear volume is determined by measuring the circular wear scar diameter (2a) on the hemispherical tip of the pin and computing the corresponding volume of the spherical segment by the following standard solid geometry equations:

$$V = \pi/6 h (3a^2 + h^2) \quad (1)$$

$$h = R - (R^2 - a^2)^{1/2} \quad (2)$$

Substituting for h in [1]:

$$V = \pi/6 [R - (R^2 - a^2)^{1/2}] \{3a^2 + [R - (R^2 - a^2)^{1/2}]^2\} \quad (3)$$

where

V volume of spherical segment (wear volume)

a radius of base of spherical segment (wear radius)

h height of spherical segment (axial pin movement due to pin wear)

R hemispherical radius (pin tip radius)

It should be noted that the wear volume increases with the cube of the wear scar diameter. Therefore, it is necessary to compare wear volume rather than wear scar diameter to determine accurate wear ratios for different tests. The cubic nature of the relationship is illustrated in Fig. 9 which shows the wear volume as a function of wear scar diameter for pin hemispherical tips of various radii.

Disk wear is determined by recording the shape of the wear track with a stylus profilometer, computing the corresponding area, and multiplying by the average circumference of the wear track to obtain the wear volume. This process is greatly simplified with a profilometer that automatically computes the area of the profile below a reference line which, in this case, is the unworn surface on either side of the wear track.

REFERENCES

1. DellaCorte, C.: "Tribological Properties of Alumina-Boria-Silicate Fabric from 25 °C to 850 °C," STLE Preprint No. 88-TC-3E-1, 1988.
2. Alger, D. L.: "Progress Toward the Evaluation of a Stirling Space Engine," SAE Techn. Paper 880545, 1988.
3. Fairbanks, J. (Conference Organizer): Proceedings of the 1987 Coatings for Advanced Heat Engine Workshop, U.S. Dept. of Energy, Conference 870762, July 1987.
4. Fusaro, R. L.: "Geometrical Aspects of the Tribological Properties of Graphite Fiber Reinforced Polyimide Composites," ASLE Transactions, 26, 2, 209-221, 1983.
5. Benzing, R., et. al: "Friction & Wear Devices," Ind. El. Am. Soc. of Lubr. Engr. Publication, 1976.
6. Hannink, R. H. J. and Swain, M. V.: J. Aust. Ceram. Soc. 18, 53 (1983).
7. Bonham, C. D. and DellaCorte, C.: "Computerized Data Acquisition for Tribological Tests," to be presented at the STLE Annual Meeting, Denver, CO, 1989.

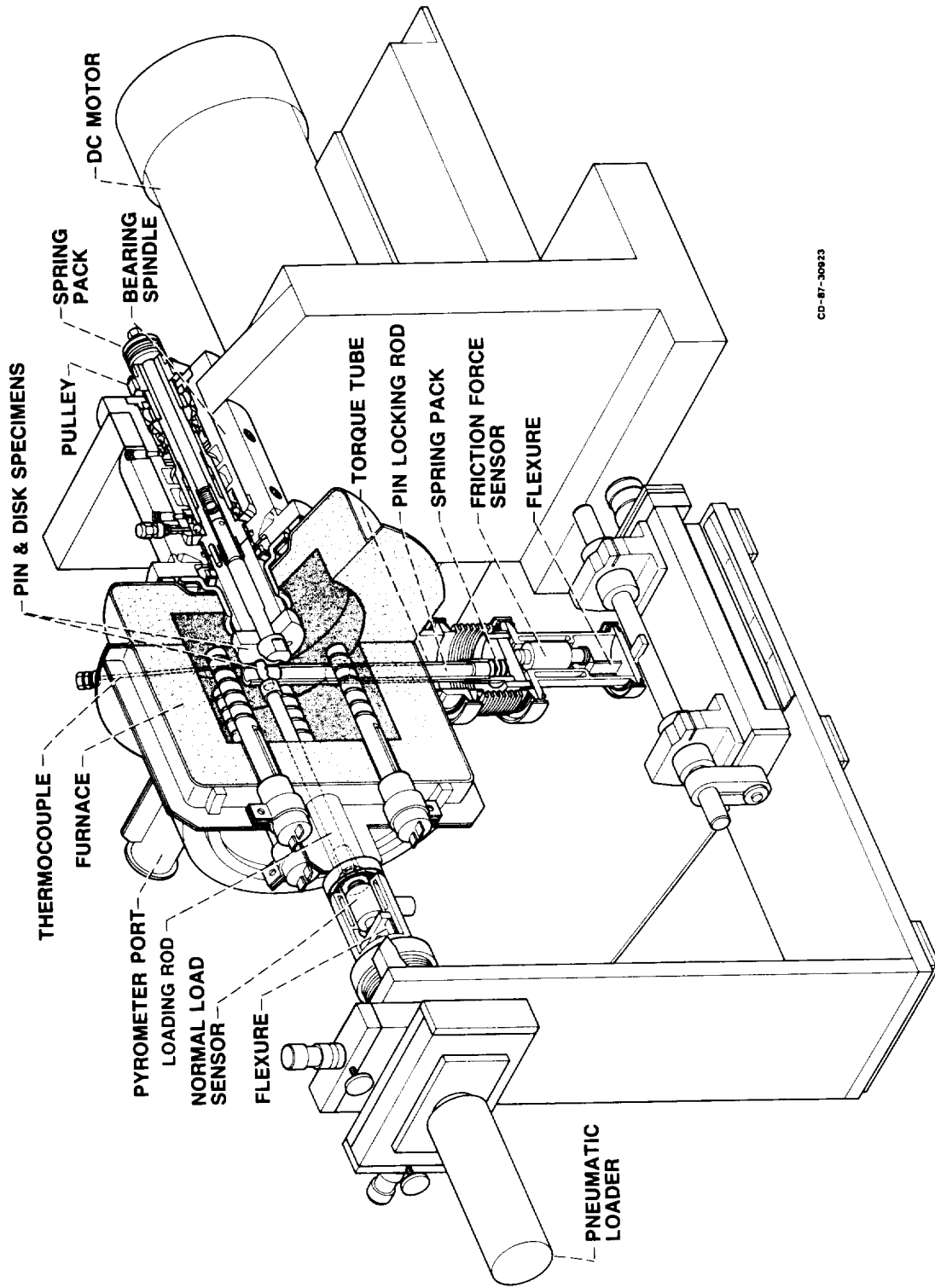

CD-87-30823

FIGURE 1. - HIGH-TEMPERATURE PIN ON DISK TRIBOMETER.

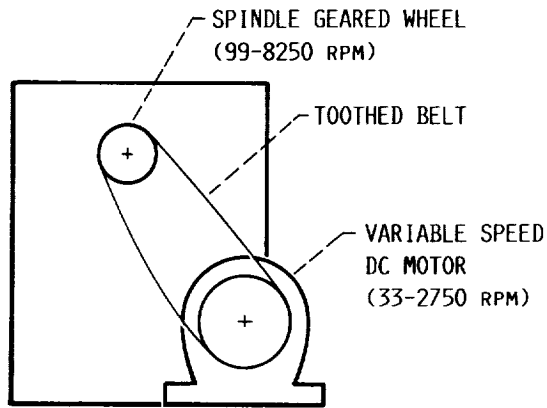

(a) UNIDIRECTIONAL ROTATING DRIVE, 3-1 SPEED INCREASER.

MAX. AMPLITUDES: POS. 1 = $\pm 45^{\circ} \times 1:5:1 = \pm 30^{\circ}$
 POS. 2 = $\pm 45^{\circ} \times 1:1:5 = \pm 60^{\circ}$

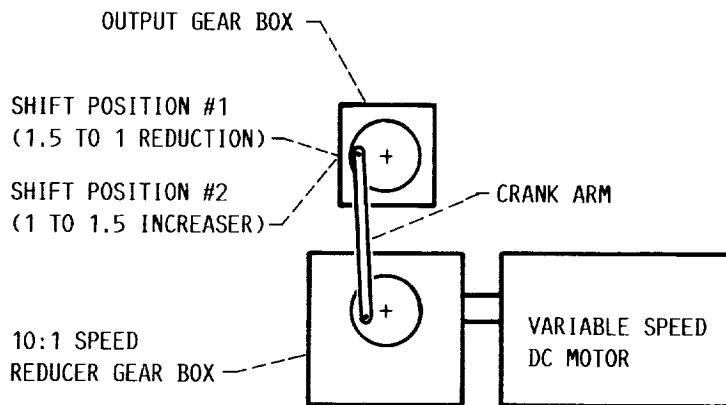

(b) OSCILLATING DRIVE.

FIGURE 2. - SCHEMATICS OF TRIBOMETER DRIVES.

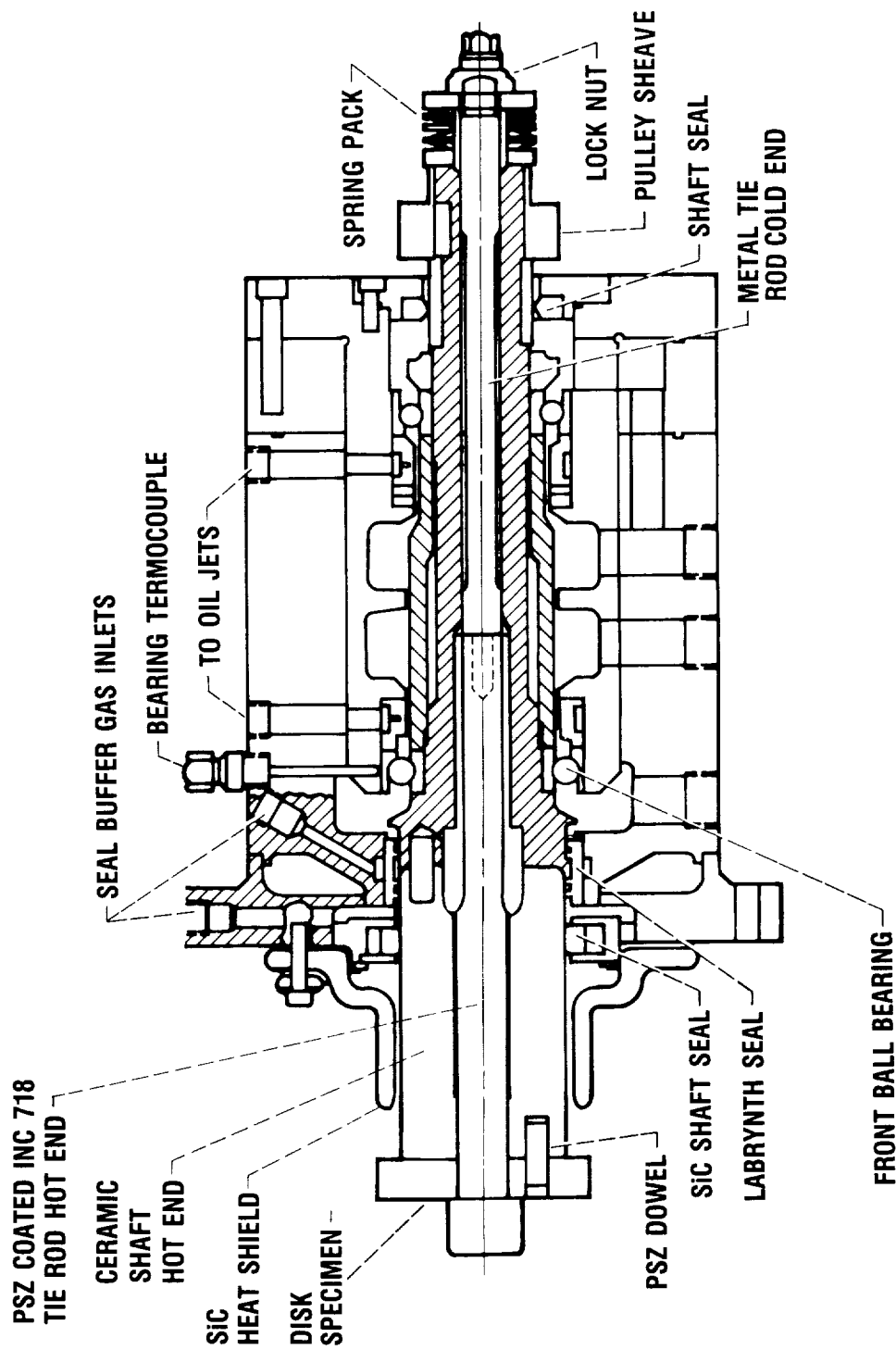

FIGURE 3. - DRIVE SPINDLE FOR HIGH-TEMPERATURE TRIBOMETER.

ORIGINAL PAGE IS
OF POOR QUALITY

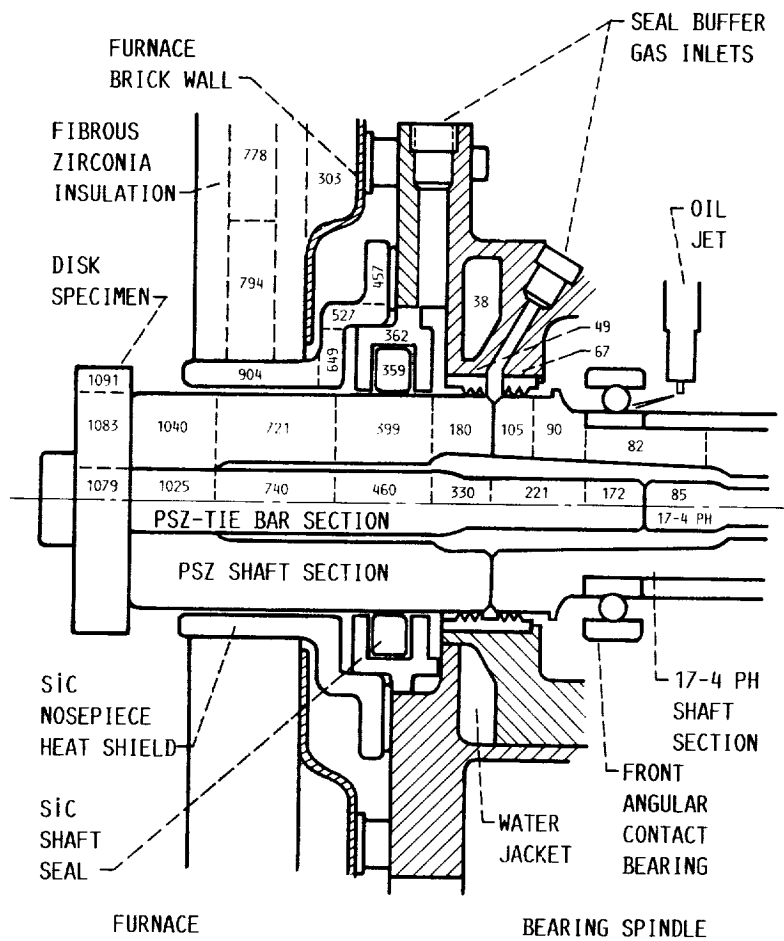
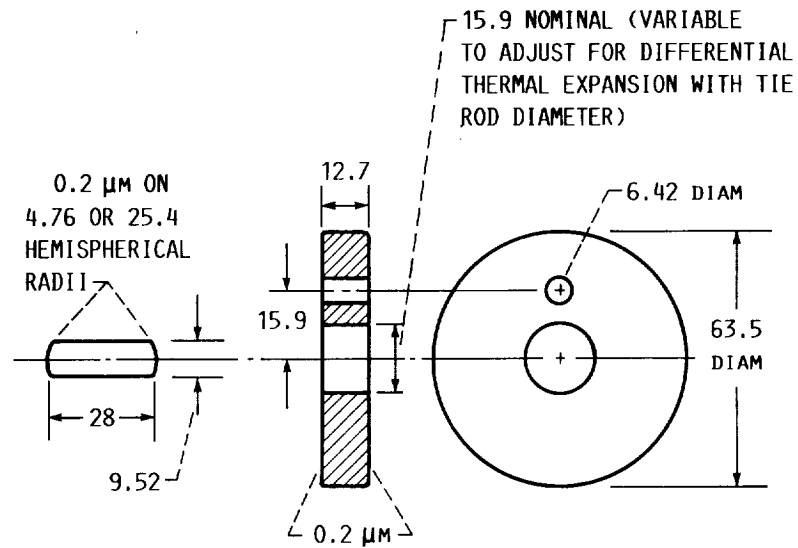

FIGURE 4. - TEMPERATURE MAP OF THE TRIBOMETER FROM THE FURNACE TO THE SUPPORT BEARING SPINDLE. (THERMAL ANALYSIS WAS PERFORMED FOR CASE IN WHICH 9 MOLE PERCENT MgO STABILIZED PSZ IS HEATED ABOVE MAXIMUM RECOMMENDED TEMPERATURE OF 800-900 °C FOR LONG LIFE STABILITY).



(a) PIN DESIGN.

(b) DISK DESIGN.

NOTE: DIMENSIONS IN MM

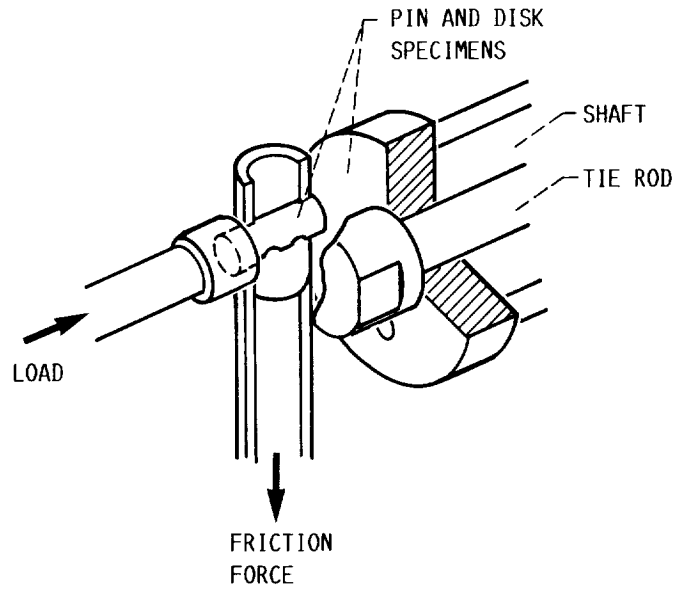

(c) ISOMETRIC OF SPECIMEN MOUNTINGS.

FIGURE 5. - TEST SPECIMENS.

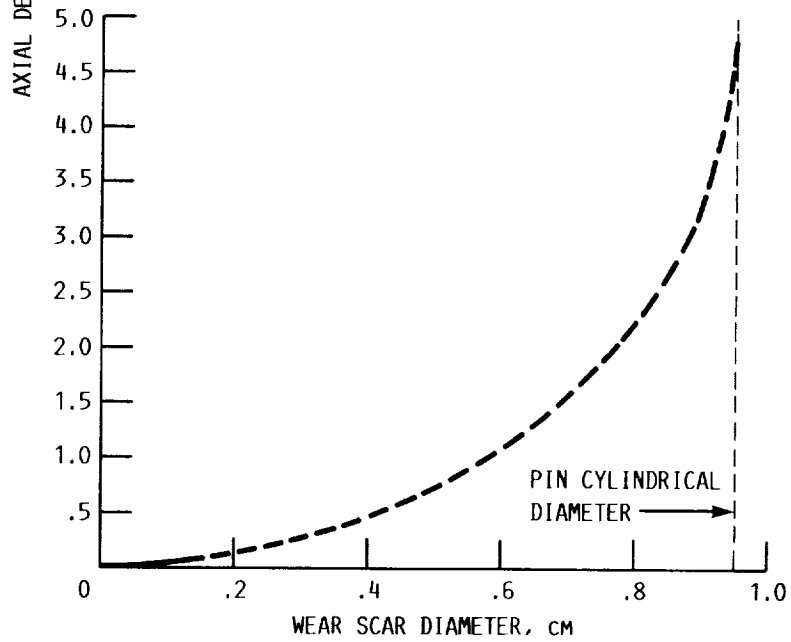
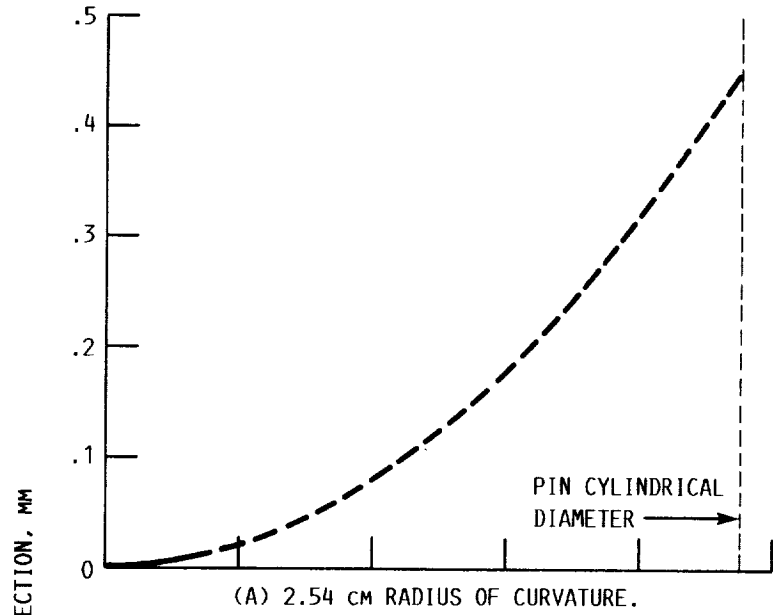

FIGURE 6. - DEFLECTION VERSUS WEAR SCAR DIAMETER.

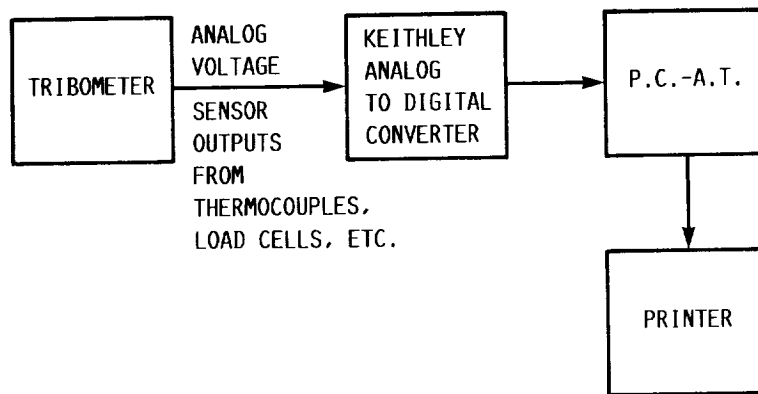
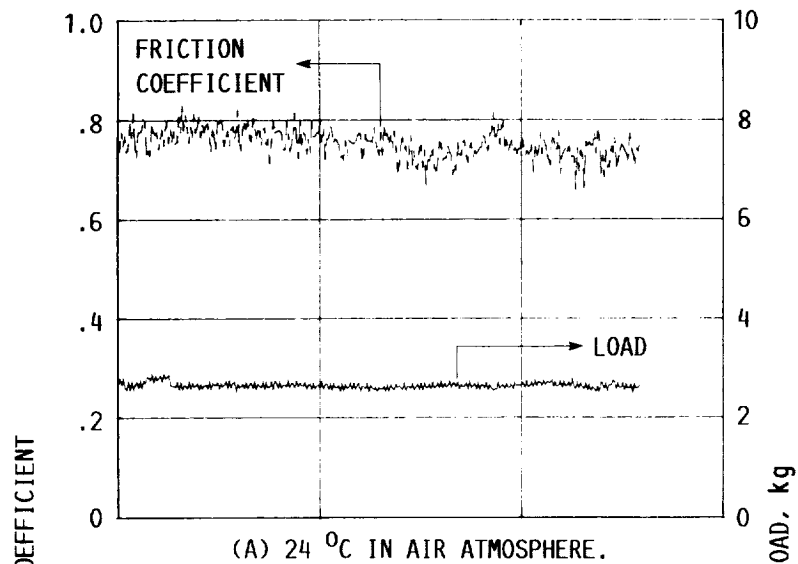
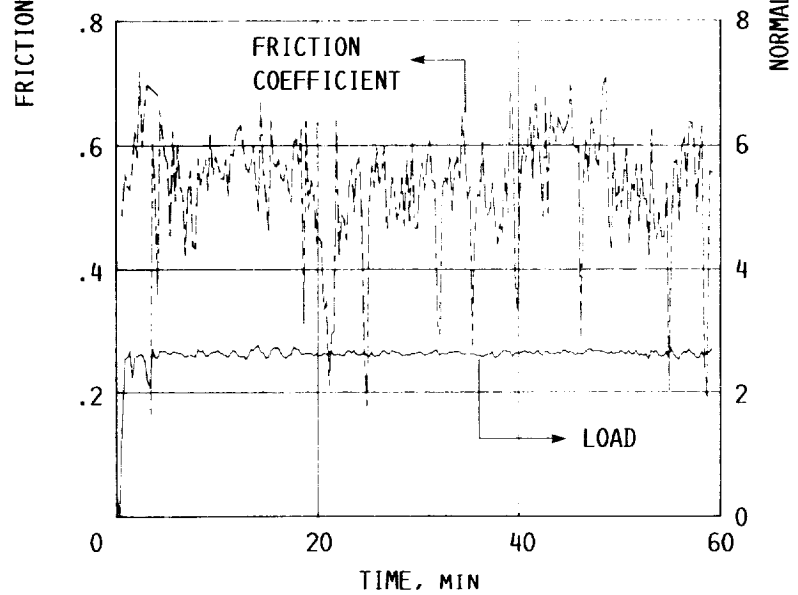

FIGURE 7.- SCHEMATIC OF COMPUTERIZED DATA ACQUISITION SYSTEM.



(A) 24 °C IN AIR ATMOSPHERE.



(B) 800 °C IN AIR ATMOSPHERE.

FIGURE 8. - COMPUTER GENERATED PLOT OF FRICTION COEFFICIENT AND LOAD. 25 VOL % SiC WHISKER-REINFORCED Al_2O_3 COMPOSITE PIN AND DISK; 1000 RPM (2.7 M/S).

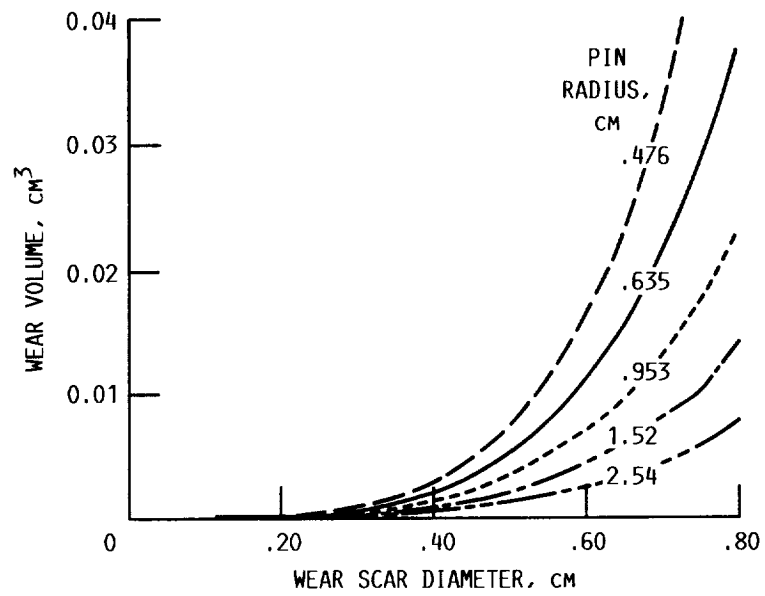

FIGURE 9. - VOLUME VERSUS WEAR SCAR DIAMETER, RADIUS OF CURVATURE VARIED.

| | | | | | |
|--|--|--|---|---|-------------------|
| 1. Report No. NASA TM-102405 | | 2. Government Accession No. | | 3. Recipient's Catalog No. | |
| 4. Title and Subtitle A New Test Machine for Measuring Friction and Wear in Controlled Atmospheres to 1200 °C | | | | 5. Report Date November 1989 | |
| | | | | 6. Performing Organization Code | |
| 7. Author(s) Harold E. Sliney and Christopher DellaCorte | | | | 8. Performing Organization Report No. E-5093 | |
| | | | | 10. Work Unit No. 505-63-1A | |
| 9. Performing Organization Name and Address National Aeronautics and Space Administration Lewis Research Center Cleveland, Ohio 44135-3191 | | | | 11. Contract or Grant No. | |
| | | | | 13. Type of Report and Period Covered Technical Memorandum | |
| 12. Sponsoring Agency Name and Address National Aeronautics and Space Administration Washington, D.C. 20546-0001 | | | | 14. Sponsoring Agency Code | |
| | | | | | |
| 15. Supplementary Notes Prepared for the Annual Meeting of the Society of Tribologists and Lubrication Engineers, Denver, Colorado, May 7-11, 1990. | | | | | |
| 16. Abstract <p>This paper describes a new high temperature friction and wear test apparatus (tribometer) at NASA Lewis Research Center, Cleveland, Ohio. The tribometer can be used as a pin-on-disk or pin-on-ring configuration and is specially designed to measure the tribological properties of ceramics and high temperature metallic alloys from room temperature to 1200 °C. Sliding mode can be selected to be either unidirectional at velocities up to 22 m/sec or oscillating at frequencies up to 4.5 Hz and amplitudes up to ±60°. The test atmosphere is established by a controlled flow rate of a purge gas. All components within the test chamber are compatible with oxidizing, inert, or reducing gases.</p> | | | | | |
| 17. Key Words (Suggested by Author(s)) High-temperature tribometer Wear test machine Ceramic friction Wear machine | | | 18. Distribution Statement Unclassified - Unlimited Subject Category 24 | | |
| 19. Security Classif. (of this report) Unclassified | | 20. Security Classif. (of this page) Unclassified | | 21. No of pages 22 | 22. Price* A03 |



National Aeronautics and
Space Administration

Lewis Research Center
Cleveland, Ohio 44135

Official Business
Penalty for Private Use \$300

FOURTH CLASS MAIL

ADDRESS CORRECTION REQUESTED



Postage and Fees Paid
National Aeronautics and
Space Administration
NASA 451

NASA
