

LDR Structural Experiment Definition

R. A. Russell
Langley Research Center
Hampton, VA 23665-5225
Summarized R. E. Freeland

A system study to develop the definition of a structural flight experiment for a large precision segmented reflector on Space Station was accomplished by The Boeing Aerospace Company for NASA's Langley Research Center. The objective of the study was to use a JPL LDR baseline configuration [1] as the basis for focusing an experiment definition, so that the resulting accommodation requirements and interface constraints could be used as part of the mission requirements data base for Space Station.

The ground rules for the study were that (1) the experiments would be conducted on the space station, (2) the test hardware would serve as a test bed for future precision segmented structures experiments, (3) the primary mirror would use the deployable PAC truss structure, (4) the primary mirror facets would be assembled using telerobotics, (5) the system identification techniques would already have been developed, (6) structural characterization would be required, and (7) chopping would occur at the sensors that require it.

Results of the study define three Space Station-based experiments to demonstrate the technologies needed for an LDR-type structure. The basic experiment configurations are the same as the JPL baseline except that the primary mirror truss is ten meters in diameter instead of twenty. The primary objectives of the first experiment are to construct the primary mirror support truss and to determine its structural and thermal characteristics. Addition of an optical bench, thermal shield and primary mirror segments, and alignment of the optical components, would occur on a second experiment. The structure would then be moved to the payload pointing system for pointing, optical control, and scientific optical measurement for a third experiment.

As shown in FIGURE 1, Experiment 1 will deploy the primary support truss while it is attached to the instrument module structure. If possible, it will be deployed repeatedly to demonstrate reliability of kinematic deployment. After each deployment, the structural adequacy will be measured. After final deployment, the dynamic and thermal characteristics will be measured. The ability to adjust the mirror attachment points and to attach several dummy primary mirror segments with a robotic system will also be demonstrated.

Experiment 2 will be achieved by adding new components and equipment to experiment one. The optical bench structure, including the preassembled secondary, tertiary, and quaternary mirrors, will be attached to the instrument module. The thermal shield will then be attached after several lightweight composite mirror segments have been assembled. After installation of the

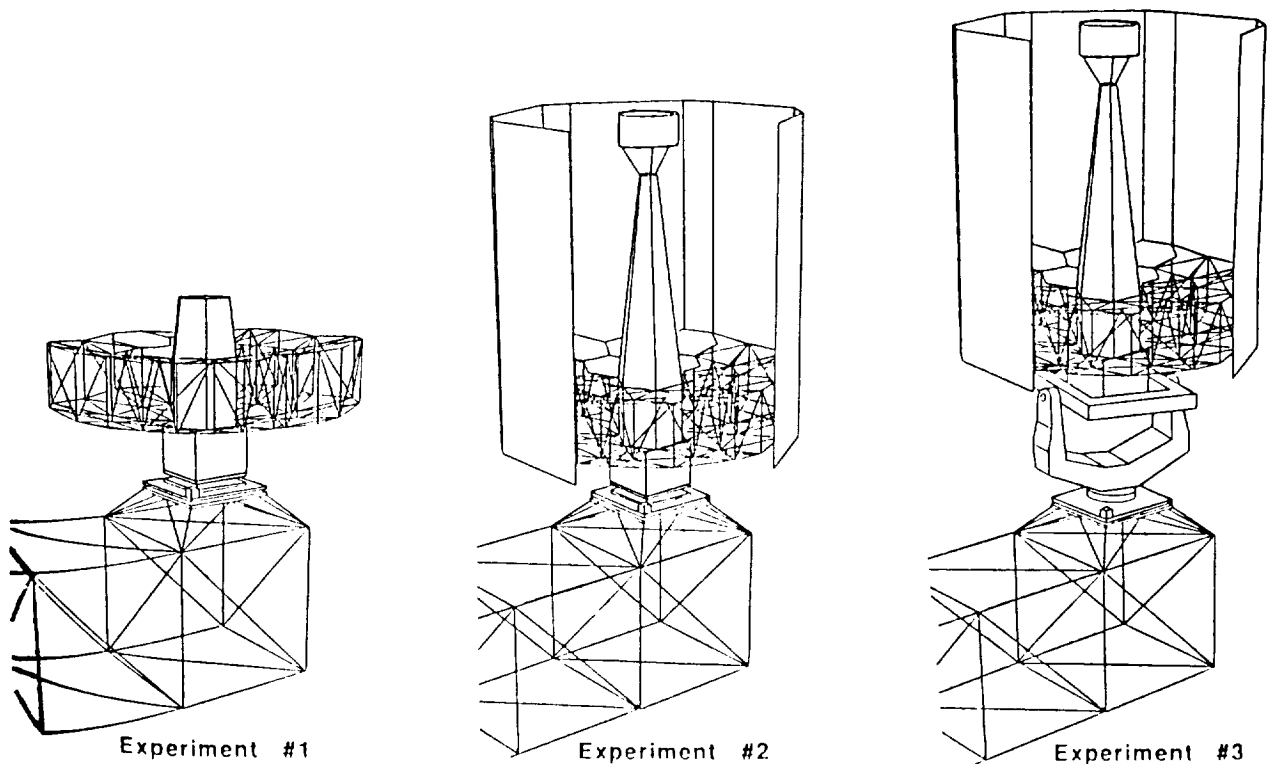

FIGURE 1. The Large Precision Segmented Structures Testbed

optical alignment system and prototype cryogenic cooling system, the optical system will be evaluated.

Experiment 3 will demonstrate advanced control strategies, active adjustment of the primary mirror alignment, and technologies associated with optical sensing; there will be particular emphasis on sensing for the alignment and control of the quaternary mirror elements. Equipment to be added for this experiment will include a payload pointing system, fine pointing system, star tracker, and primary mirror alignment system. This experiment will also address the feasibility of providing an electro-mechanical quasi-static adjustment mechanism for the primary mirror panels.

Reference:

1. A Lightweight Low Cost Large Deployable Reflector (LDR), Paul N. Swanson, JPL Report D-2283, June 1985.