

NASA Technical Memorandum 101974

The U.S. Space Station and Its Electric Power System

Ronald L. Thomas
Lewis Research Center
Cleveland, Ohio

(NASA-TM-101974) THE US SPACE STATION AND
ITS ELECTRIC POWER SYSTEM (NASA) 26 p
CSCL 10B

N90-13596

Unclass

G3/20 0252618

Presented at
The Tenth South Pacific Electrical International Convention
sponsored by the Electrical Development Association of Queensland Inc.
Brisbane, Queensland, Australia, May 2-5, 1988

NASA



THE U.S. SPACE STATION AND ITS ELECTRIC POWER SYSTEM

Ronald L. Thomas
Director, Space Station Freedom Directorate
National Aeronautics Space Administration
Lewis Research Center
Cleveland, Ohio U.S.A.

SUMMARY

The United States has embarked on a major development program to have a space station operating in low earth orbit by the mid-1990's. This endeavor is a multi-billion dollar effort that draws on the talents of NASA and most of the aerospace firms in the U.S. Plans are being pursued to include the participation of Canada, Japan and the European Space Agency in the space station. From the start of the program there has been a focus on the utilization of the space station for science, technology and commercial endeavors. These requirements have been utilized in the design of the station and manifest themselves in: pressurized volume; crew time; power availability and level of power; external payload accommodations; microgravity levels; servicing facilities; and the ability to grow and evolve the space station to meet future needs. President Reagan directed NASA to develop a permanently manned space station in his 1984 State of the Union message. Since then the definition phase has been completed and the development phase initiated. A major subsystem of the space station is its 75 kW electric power system. The electric power system has characteristics similar to those of terrestrial power systems. Routine maintenance and replacement of failed equipment must be accomplished safely and easily and in a minimum time while providing reliable power to users. Because of the very high value placed on crew time it is essential that the power system operate in an autonomous mode to minimize crew time required. The power system design must also easily accommodate growth as the power demands by users are expected to grow. This paper provides an overview of the U.S. space station with special emphasis on its electrical power system.

INTRODUCTION

The United States space station program has been referred to as the next logical step. The decision to proceed with the space station was announced by President Reagan in his 1984 State of the Union Message. The president spoke of: (1) a permanently manned space station; (2) developing the station within a decade; and (3) inviting international participation. President Reagan approved the space station on the basis of maintaining U.S. leadership in space and realizing the scientific, technological and commercial benefits of a permanently manned presence in space. The space station is to begin operating in low earth orbit by the mid-1990's and will draw on the talents of the National Aeronautics and Space Administration and most of the major aerospace companies in the U.S. Negotiations have been completed for including participation with Canada, and are nearly completed for including participation with the European Space Agency and Japan. A unique feature of the space station is its ability to provide for a permanent crew in a microgravity environment. Astronauts will be aboard the station 24 hr a day, every day. This provides enormous opportunities to perform basic science experiments,

observations, and to make new discoveries in materials research and life sciences. In addition to the research done in pressurized modules, the space station and its platforms will provide an opportunity for studies of the Earth's atmosphere, land masses and oceans. Telescopes can be attached to the space station to look out to the stars, the solar system and down upon the Earth. In addition to the science and observations, the space station will provide a means of servicing satellites and payloads and will serve as a place for assembling future space projects that are too large to launch in the space shuttle. The space station will be assembled for the first time in space. It will be able to sustain failures and still operate allowing for maintenance, repairs and replacements in space. The space station serves as a necessary precursor to any future manned explorations such as a man-base on the moon or a mission to the surface of Mars. The station will allow much of the assembly of the major elements for such missions to be accomplished in space, thereby greatly reducing the energy required for a direct launch from Earth. In addition the space station will provide much needed psychological information on humans in space that is needed to support long duration space flight.

The electrical power system is one of the major systems that is critical to the success of the space station. The power system must provide safe, reliable power that is convenient to use and in sufficient supply to meet the needs of the users and housekeeping needs of the station. The power system must meet these needs while minimizing the valuable time of the crew during on-orbit assembly, operations and maintenance. This requires a power system that is designed with redundancy and automation and is packaged to be easily maintained. Further, the challenge requires that up-front development costs be kept to a reasonable level while keeping the life cycle and operations cost to an acceptable level. This paper describes the present status and design of the U.S. space station with special attention given to describing the electric power system.

SPACE STATION DESCRIPTION

Major Elements and Systems

The U.S. space station is planned to be accomplished in two major phases followed by evolutionary growth. The design of phase one is shown in figure 1. The transverse boom is a 5 by 5 m (16.4 by 16.4 ft) truss beam 140 m (459 ft) long that is assembled from the National Space Transportation System (NSTS) by the crew. At each end of the truss are located the two electric power modules (total four) each with two solar array wings. In board of the power modules are the two alpha joints. These joints allow 360° of continuous rotation so the solar arrays can remain pointed toward the sun while the modules remain parallel to the velocity vector of the space station orbit. All the electric power flows across the alpha joints. In board of the alpha joints are the large thermal radiators for rejection of the waste thermal energy. These are large heat pipes connected to the central two phase thermal rejection system. Next is the truss work that supports the thrusters for the hydrogen oxygen propulsion system. Storage tanks of hydrogen and oxygen can also be seen located within the truss. These thrusters provide thrust for station maneuvers and unloading of the gyros used for station attitude control. Additional small thrusters are located at the end of the boom over the modules that are used for station keeping. At the center of the station are located the modules and nodes. The two modules located near the NSTS are the U.S. laboratory and

habitation modules. These are connected at both ends by nodes. Behind these are located the European Space Agency (ESA) laboratory module and the Japan laboratory module (JEM). Below the U.S. modules can be seen a U.S. logistics module that gets interchanged with a replacement logistic module during NSTS visits.

Figure 2 shows a cutaway of the two U.S. modules, the interconnecting nodes and the logistics module. The pressurized volume that is provided for the crew to live and work in is a very important part of the space station. The hab and lab modules are structurally the same (common) but are outfitted differently to provide for their different uses. A common module is a cylinder approximately 4.6 m (15 ft) in diameter and 12.2 m (40 ft) long. Each module is equipped with common subsystems: power, life support, thermal, communications, etc. The four connecting nodes are built similarly to the modules and are approximately 4.6 m (15 ft) in diameter and 4.6 m (15 ft) long. The modules are configured inside to provide maximum utilization of volume. Standard racks are used in the modules and nodes to allow easy replacement of experiments and other equipment. Since the logistics modules must make many trips up and back to the space station on the NSTS it is very important to minimize their weight. For this reason the logistics modules may not be made of common construction with the other modules and nodes. However, they will use standard size racks to allow ease of exchanging experiments and other equipment.

It can be seen in figure 1 that the NSTS is docked to a node to allow passage of the crew members and removal of equipment from the STS cargo bay by a S.S. telerobotic arm. A closer view of the STS docked to the space station can be seen in figure 3. The space station is expected to orbit the Earth at a nominal altitude of 408 km (220 n mi) at a 27.5° inclination orbit. The space station will circle the Earth every 91 min with about 55 min in the sunlight and 36 min in the Earth's shadow.

Figure 4 shows the second phase of the space station as it is planned to evolve from phase one. If approved in the early 90's this phase would provide for an upper and lower boom. These booms would provide much more accommodations for payloads with the upper used for experiments and payloads looking out to the stars and solar system and the lower for Earth observations. Also the port and starboard keels allow space for attaching payloads, servicing facilities and storage. During phase two it is planned to increase the power from 75 to 125 kW. This would be accomplished with two 25 kW Brayton solar dynamic power systems located at each end of the central boom.

National Space Transportation System

The National Space Transportation System (NSTS) will be used for transporting the space station into orbit (fig. 5). A permanently manned space station requires a transportation system that is safe, dependable, manned and flies frequently. The NSTS is essential to the space station and has shaped many of its key parameters such as the diameter and length of the modules. The NSTS can carry approximately 18 000 Kg (40 000 lb) of payload in its cargo bay to a nominal 200 n mi orbit and return about the same amount of cargo back to Earth. Nineteen NSTS flights are planned to complete the phase one space station. Twelve of these are assembly flights to bring up space station elements and seven are logistics flights for ferrying crews, payloads and needed materials.

During the mature operations phase it is planned that the NSTS will visit the space station about 5 times per year. Figure 6 shows several key assembly flights including the completion of the phase one capability (assembly flight 12) and completion of the phase two capability (assembly flight 16). The NSTS also serves as the construction base during the early assembly flights providing the living quarters for the crew and a construction pad for the initial assembly of the station.

International Participation

When directing NASA to develop the space station, President Reagan also invited our friends and allies to participate. In the spring of 1985, NASA signed bilateral Memoranda of Understanding (MOU) with Canada, the European Space Agency, and Japan that provided a framework of cooperation during the phase B definition and preliminary design of the space station. International elements are a part of the phase one configuration. To date the agreements indicate that NASA is to develop the station infrastructure and be overall program manager. ESA is considering the development of an attached pressurized module, a polar platform and a man-tended free flyer. Japan is to develop the Japanese Experiment Module (JEM). Canada is to develop the Mobile Servicing System which will be used to help assemble and maintain the space station. Canada developed the Space Shuttle's Remote Manipulation System (RMS) and is pursuing space activities in remote sensing, space science, technology development and communications. Final agreements have been signed between Canada and the United States for space station participation. The negotiations with ESA and Japan for space station cooperation during development and operations are now underway. These arrangements will enhance the space station capabilities and will provide for the operational expenses to be shared. Figure 7 shows the phase one space station and delineates those elements supplied by Canada, ESA and Japan and also by the four NASA Centers: Marshall, Johnson, Goddard and Lewis.

ELECTRICAL POWER SYSTEM

The large size of the phase one space station and the plans for phase two and evolutionary growth requires that the power system meets requirements more similar to those for a terrestrial power system than for a typical dedicated spacecraft power system. Additional requirements are imposed on the power system because the space station is permanently manned and will be used to support a wide range of changing activities and users. The space station power system is required to be user-friendly, reliable, maintainable and adaptable to growth. To provide for a power system to meet these requirements a variety of trade studies and technology options were evaluated during the space station definition phase (Nored and Bernatowicz, 1986; Labus and Cochran, 1987; and Teren, 1987). The large solar arrays that generate the 75 kW of electrical power for the phase one space station are the most prominent feature on the space station. The power system is a very significant part of the space station mass, stability and control, and cost. A simplified block diagram of the electric power system is shown in figure 8. The 8 solar array (wings) generate 187 kW of power during the 54.8 min of the orbit that the space station is sunlit. During this sunlit period 97 kW is used to charge the batteries and 90 kW goes into the main converters. During the shadow portion of the orbit the 90 kW is drawn from the batteries. The main converters charge

the 160 V dc power from the arrays or batteries into 440 V ac at 20 kHz. The ac power is distributed through the power management and distribution system (PMAD) to the system loads. The system is sized to provide 75 kW of continuous power to the system loads throughout the orbit at the end of 4 years. The 77 kW shown in figure 8 provides for design margin at this time in the development. The following is a brief description of the power system.

Photovoltaic Power Modules

The phase one power system consists of four identical photovoltaic power modules each consisting of two solar array wings, an Integrated Equipment Assembly (IEA) a beta gimbal assembly and a radiator (fig. 10). The total mass of each solar power module is about 5500 Kg (12 000 lb). The IEA contains the energy storage system and the electrical assemblies. The beta gimbal allows the solar array to rotate during the year to keep the solar wings pointed directly at the sun. Electric power from the array is transferred across the Beta joint through an electromechanical roll ring.

Solar array wings. - The eight solar array wings are an accordion-folded flexible blanket supported by a deployable mast. An earlier NASA flight experiment in the STS demonstrated this concept and thereby established a high degree of confidence in the approach. Figure 10 shows the experimental array extending from the assembly bay of the STS during the 1984 STS-41D flight (Ref. NASA, 1986). The solar array was built by Lockheed Missiles and Space Company and consisted of 84 hinged panels for a total length of approximately 32 m (105 ft) and a width of 4 m (13 ft). In the experiment only three panels contained solar cells with the other panels having dummy cells for mass simulation. The array was extended and retracted several times and showed that structural results were generally predictable and the solar cells were not damaged. The array wing design for the space station has two flexible blankets that are supported by a deployable/retractable center mast. Each blanket will be stored in its own container/cover assembly. Each of the eight array wings is approximately 9 by 33 m (30 by 108 ft) with a mass of 549 kg (1207 lb). The solar cells selected for the arrays are 8 by 8 cm (3.1 by 3.1 in.) size, 8-mil thick, silicon wrap-through. There are a total of 32 800 cells on each of the array wings for a total of 262 400 cells for 75 kW. A Kapton substrate has been selected for mounting the solar cells. It will be necessary, however, to coat the Kapton to increase its life in the atomic oxygen environment found in low Earth orbits. Several promising coatings are under development.

The design of the solar arrays represents an approach to lower cost lower weight arrays that can be packaged in a small volume. The deployment/retraction feature allows the arrays to be more easily packaged for shipment into space and then returned when they are replaced at the end of their life. It is desirable to keep the voltage as high as possible to reduce resistance loss and weight but to keep the voltage under 200 V dc because of possible plasma interactions with the low Earth orbit environment that could cause arcing. An array voltage of 160 V dc was selected. Environmental tank tests of the array design are planned to verify that the performance at 160 V dc is acceptable. The arrays will be designed to deliver their rated output at the end of 4 years and are expected to achieve a 10 year lifetime.

Energy storage system. - Energy storage to supply power during the eclipse portion of the orbit is provided by nickel-hydrogen (NiH₂) independent pressure vessel (IPV) batteries. These batteries are used on many geo-synchronous spacecraft and have worked quite well (450 charge/discharge cycles in 5 years). However in the low Earth orbit for space station many more charge/discharge cycles are required because of the 91 min orbit (28 000 cycles in 5 years). Much technology work has been done over the last several years to increase the number of cycles. Endurance tests of NiH₂ batteries simulating the low-Earth environment have been initiated to verify a 5-year lifetime. NiH₂ batteries have been selected for space station because they offer about a 50 percent weight reduction over the well established and mature nickel-cadmium batteries used on most spacecraft to date. This results in a savings of about 2100 kg (4620 lb) per photovoltaic power module. Figure 11 shows a representative IPV nickel-hydrogen battery pack for the space station.

On space station these batteries will be packaged in standard mechanical electrical thermal boxes referred to as Orbital Replacement Units. These ORU's are approximately 15 by 11 by 6.7 cm (38 by 28 by 17 in.). Also packaged in ORU's are the electrical charge/discharge equipment needed as well as other electrical equipment in the photovoltaic power module. Standard ORUs are used for the electrical components and the batteries (fig. 12). The design of these ORU's is based on Intelsat V designs and allows the ORU's to be replaced easily by the astronauts or by using a telerobotic servicer. Each of the four photovoltaic power modules contains five 81 A-hr batteries. Each battery consists of 90 IPV cells which are packaged in 30 cells per ORU. A total of 15 ORU's are used in each photovoltaic power module for the batteries. The space station storage system not only stores enough energy for the eclipse period but can supply emergency power for one full orbit by discharging beyond the normal depth of discharge of 31.5 percent. The battery and electrical ORU's are packaged in an Integrated Equipment Assembly (IEA) for ease of assembly and storage in the NSTS and assembly on orbit. The battery and electrical equipment are attached to cold plates to maintain their temperature within an allowable range. The cold plates are an integral part of the IEA. Figure 13 shows the IEA with its cold plates and 32 ORU's.

Power Management and Distribution System

The power management and distribution system (PMAD) for the space station has characteristics very similar to a terrestrial power system. It must provide fault protection, reliable power to the user, accommodate changes in load types and sizes and be able to accommodate power system growth. The large size of the space station compared to other satellites (75 kW initial with potential growth to 300 kW) and long cable runs requires higher voltage distribution than the 28 V dc normally used in space applications. The primary distribution is single phase 20 kHz 440 V. A 20 kHz sine wave power distribution system has not yet flown in space but offers several advantages. The alternating current allows loads to be switched at zero current and the high frequency results in much smaller lighter weight magnetic components. This results in much smaller transformers and converters which yield higher system efficiency. The 20 kHz also has very little, if any, electromagnetic interference (EMI) and no audible noise. A 25 kW 20 kHz testbed system has been built by General Dynamics and is under test at the NASA Lewis Research Center (fig. 14).

The power system architecture is shown in figure 15. The main source converters convert the solar array dc power and/or the battery power to single phase 440 V 20 kHz ac power. The primary power is transmitted across the alpha joints through roll rings to the main bus switching assemblies (MBSA). A dual ring bus system is used to provide power to the loads on the transverse boom, the nodes and modules. The power system interfaces with all the loads except those in the ESA and Japan modules, through power distribution and control assemblies (PDCA). Each PDCA is rated at approximately 18 kW and provides up to 20 load connections. Critical loads can be connected to multiple outlets in the PDCA to provide redundant power paths and increased reliability.

The PMAD system has its own control system for sensing and clearing faults and restoring power through alternate paths. Remote Bus Isolators (RBIs) are used to clear faults that occur in the ring distribution and to restore power through alternate connections. Remote Power Controllers (RPCs) in the PDCA's (fig. 16) are used to sense load faults and to protect the power system. The PDCA's are located on the transverse boom, in the photovoltaic power modules and in the pressurized modules and nodes. The PDCA's are packaged as ORUs for ease of replacement and logistics. A total of 18 PDCA's are provided for the photovoltaic power modules, U.S. habitation and laboratory modules and the four nodes. No PDCA's are provided in the ESA or JEM modules, however it is planned that both of these modules will conform to the overall electrical architecture. Main bus power is provided to the nodes and modules by penetrations in the nodes. At each penetration transformers are used to step the 440 V ac power down to 208 V ac and to provide isolation.

A dual redundant power management data bus runs throughout the station and connects to all PDCA's, main bus switching units, main inverters and beta joints. These devices are controlled by two redundant Power Management Controllers (PMC's) that provide the overall power system control. Each PMC is connected to the overall space station Data Management System (DMS). The DMS provides power system information to the astronauts for station operation and provides back to the power system controllers the load prioritization information needed by the power system.

Solar Dynamic Power Module

Following completion of the phase one space station, increased power needs are planned to be supplied by 25 kW Brayton cycle solar dynamic power modules (SDPM). The phase two space station shows a 25 kW SDPM located at each end of the transverse boom (fig. 4). Brayton cycle solar dynamic power is planned for the growth station because it is much more efficient than photovoltaic power with battery storage (approximately 20 percent compared to approximately 5 percent). The solar dynamic power system contains: (1) a concentrator to capture and focus the solar flux; (2) a receiver to absorb the solar flux and to store thermal energy in a phase change salt for the eclipse portion of the orbit; (3) a Closed Brayton Cycle (CBC) power conversion unit which uses the working gas that is heated as it passes through the receiver to drive a turbine-alternator-compressor to produce electricity; (4) a radiator that rejects the waste energy; and (5) a beta gimbal identical to the photovoltaic power module for seasonal adjustments (figs. 17 and 18). A view of how the solar dynamic module will appear when seen by an observer looking along the transverse boom is shown in the artist's sketch of figure 19. During the past

several years NASA funded a substantial advanced development program to bring the status of the concentrator and receiver technology up to the level of the CBC power conversion unit and the heat rejection system. Continued efforts are planned during the phase one development to further develop solar dynamic power so it can be used on the phase two space station when that decision is made.

Concentrator. - The concentrator is a parabolic offset reflector, gimballed about the receiver aperture center with an effective diameter of 14.4 m (47.2 ft). The concentrator consists of 19 hexagon panels that are latched together on orbit. The hexagon panels were sized to store efficiently in the NSTS during launch. Fine pointing (0.1°) is provided by two linear actuators at a slew rate of 1° per/sec.

Receiver. - The receiver is a cylinder of approximately 2.2 m (7.0 ft) in diameter and 3.0 m (9.8 ft) in length with a total mass of 1800 kg (3900 lb). Solar energy is absorbed in the receiver and used to heat the gas that drives the turbine in a closed Brayton cycle loop. The receiver also contains a phase change Eutectic salt LiF-CaF_2 that is melted during the sunlit portion of the orbit to provide thermal energy during the shadow portion of the orbit.

Power conversion unit. - The power conversion unit is a closed Brayton cycle system that consists of the turbine, alternator, compressor, recuperator, cooler and interconnecting piping. The turbine-alternator-compressor is assembled on a common shaft and rotates at a constant speed of 32 000 rpm. The working fluid is an inert gas mixture of He-Xe (molecular weight of 40) that operates nominally from 738°C (1360°F) at the turbine inlet to 49°C (120°F) at the compressor inlet. The working gas pressure varies nominally from 276 by 10^3 N/m^2 (40 lb/in.^2) to 552 by 10^3 N/m^2 (80 lb/in.^2) throughout the loop. Much experience is available on similar components from industry and government for both aircraft propulsion and terrestrial power generation (English, 1987).

The alternator generates 3 phase 240 V 1200 Hz power that is converted to single phase 440 V 20 kHz power through a frequency charger. The output of the frequency chargers and main inverters are operated in parallel to provide the 125 kW of power.

Heat rejection assembly. - The heat rejection system consists of eight pumped flurinal coolant panels similar to the design used in the NSTS. The heat rejection assembly is 21.4 m (70.2 ft) long and 8.4 m (27.6 ft) wide for a total effective rejection area of 294 m^2 (3170 ft^2). The fluid temperatures range from a maximum inlet of 171°C (340°F) to a minimum outlet of -7.8°C (18°F). The eight panels are molded in a scissor design for compact storage in the NSTS during launch.

CONCLUDING REMARKS

The United States has begun the development of a space station with the first element launch planned in the mid-1990's. This paper has briefly described the U.S. space station design and the involvement of Canada, ESA and Japan in the program. Special emphasis has been placed on describing the space station electrical power system and its photovoltaic power generation, nickel-hydrogen battery energy storage and 20 kHz ac power distribution

system. The space station electric power system, because of its high power rating (for space applications), has characteristics similar to those of terrestrial power systems. It must provide reliable power while operating in a fairly autonomous mode. It must provide automatic fault clearance, bus isolation and rerouting, and prioritized load shedding. Because of the high value placed on crew time in space, the power system must operate in such a fashion that it requires minimum crew time. Routine maintenance and replacement of failed equipment must be performed safely and easily in a minimum amount of time. The power system design must also easily accommodate growth to higher power levels as future power demand increases. The space station power system design meets these requirements. The development of the power system was initiated in December 1987. NASA Lewis is responsible for the space station electric power system development and has as its prime contractor Rocketdyne, a division of the Rockwell International Corporation.

REFERENCES

1. Nored, D.L.; and Hallinan, G.J.: Electrical Power System for the U.S. Space Station. NASA TM-88856, 1986.
2. Labus, T.L.; and Cochran, Thomas H.: Space Station Electrical Power System. NASA TM-100140, 1987.
3. Teren, F.: Space Station Electric Power System Requirements and Design, ECEC '87; Proceedings of the Twenty-second Intersociety Energy Conversion Engineering Conference, Vol. 1, pp. 39-47, NASA TM-89889 (AIAA-87-9003), 1987.
4. Solar Array Flight experiment: Final report. NASA CR-183535, 1986.
5. English, R.E.: Speculations on Future Opportunities to Evolve Brayton Powerplants Aboard the Space Station. NASA TM-89863, 1987.

ORIGINAL PAGE
BLACK AND WHITE PHOTOGRAPH



FIGURE 1. - PHASE ONE SPACE STATION.

ORIGINAL PAGE
BLACK AND WHITE PHOTOGRAPH

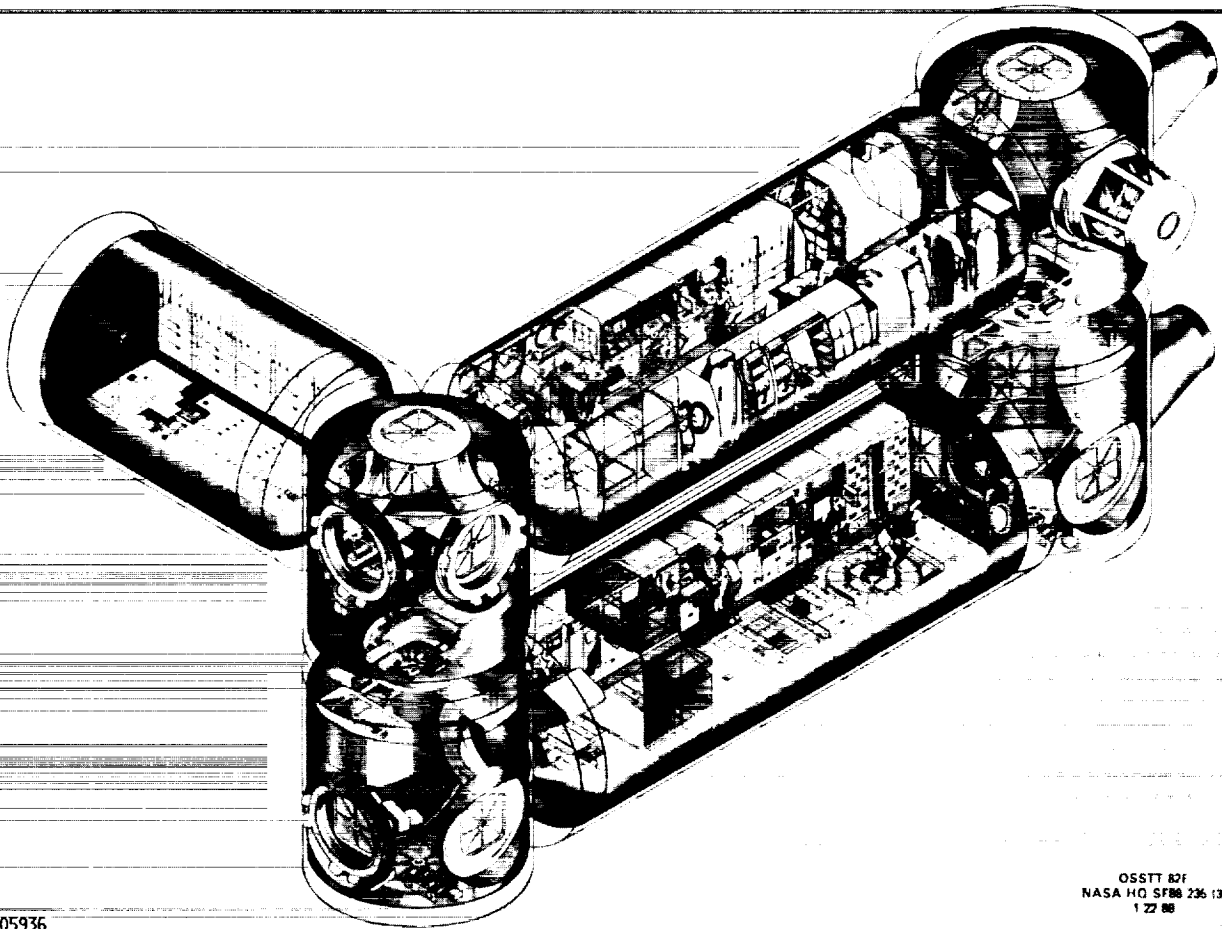

C-89-05936

OSSTT 82F
NASA HQ SF86 236 (3)
1 22 86

FIGURE 2. - U.S. LABORATORY, HABITATION, AND LOGISTICS MODULES AND CONNECTING NODES.

ORIGINAL PAGE
BLACK AND WHITE PHOTOGRAPH

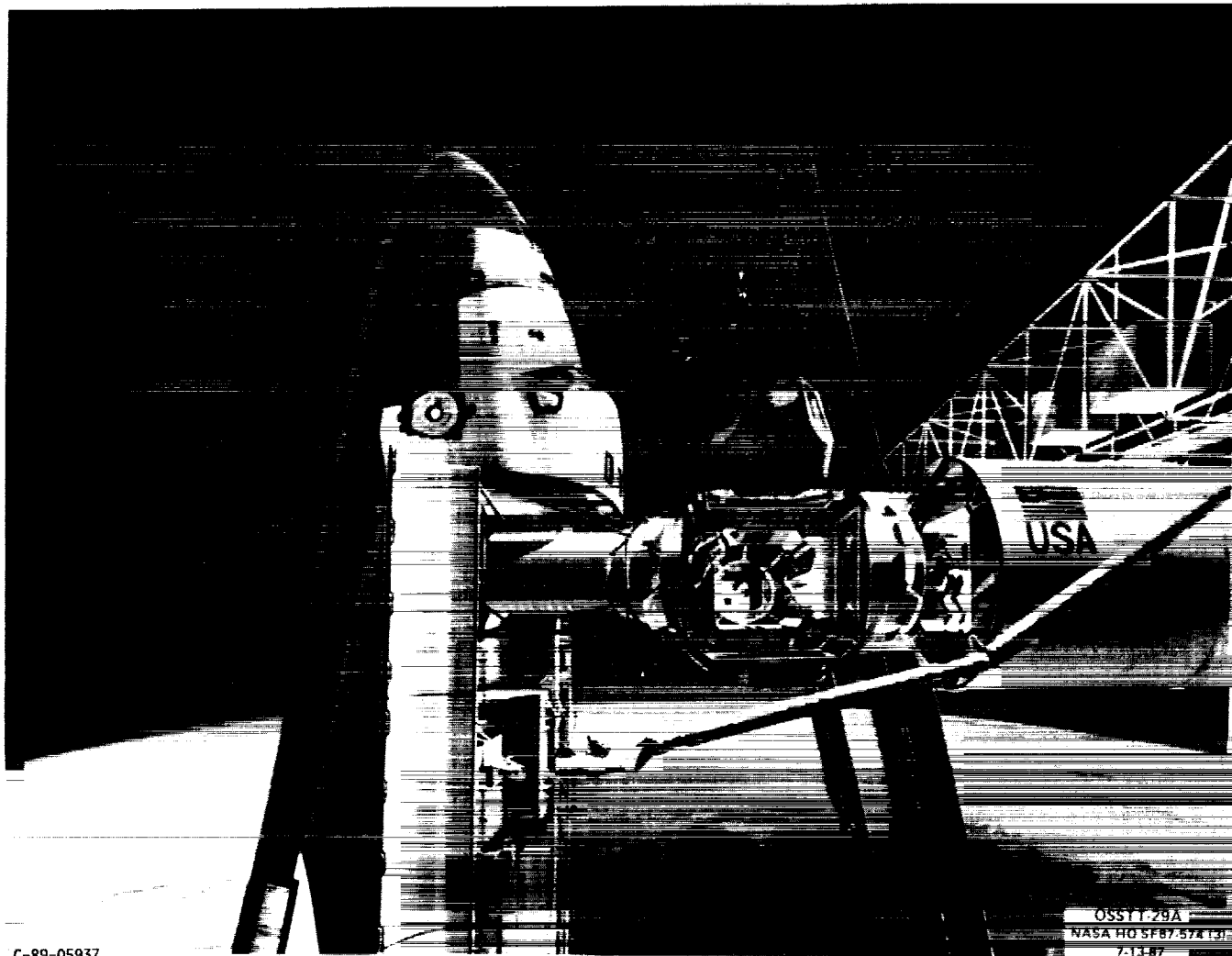

C-89-05937

FIGURE 3. - NSTS DOCKED TO THE SPACE STATION.

ORIGINAL PAGE
BLACK AND WHITE PHOTOGRAPH

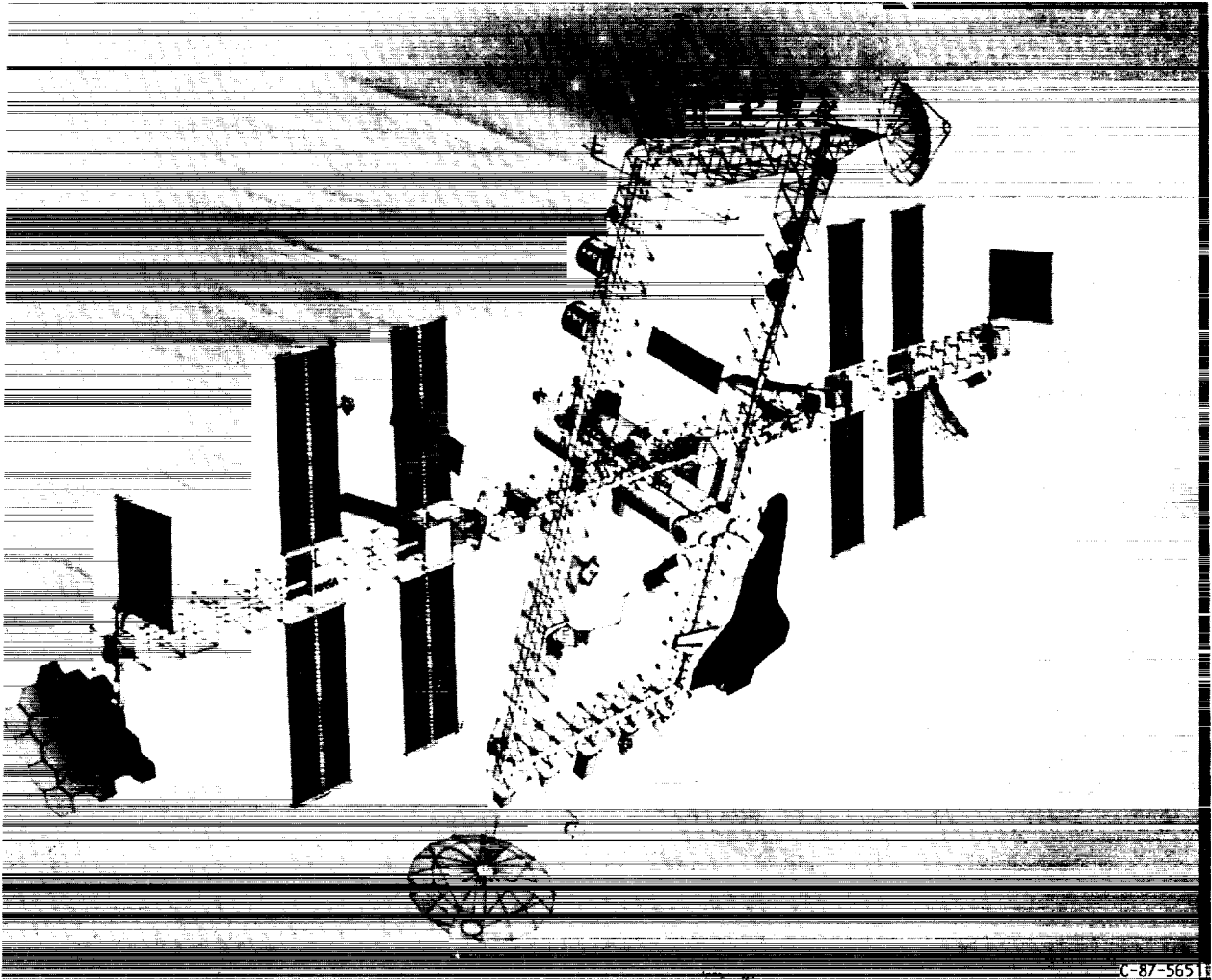

FIGURE 4. - PHASE TWO SPACE STATION.

ORIGINAL PAGE
BLACK AND WHITE PHOTOGRAPH

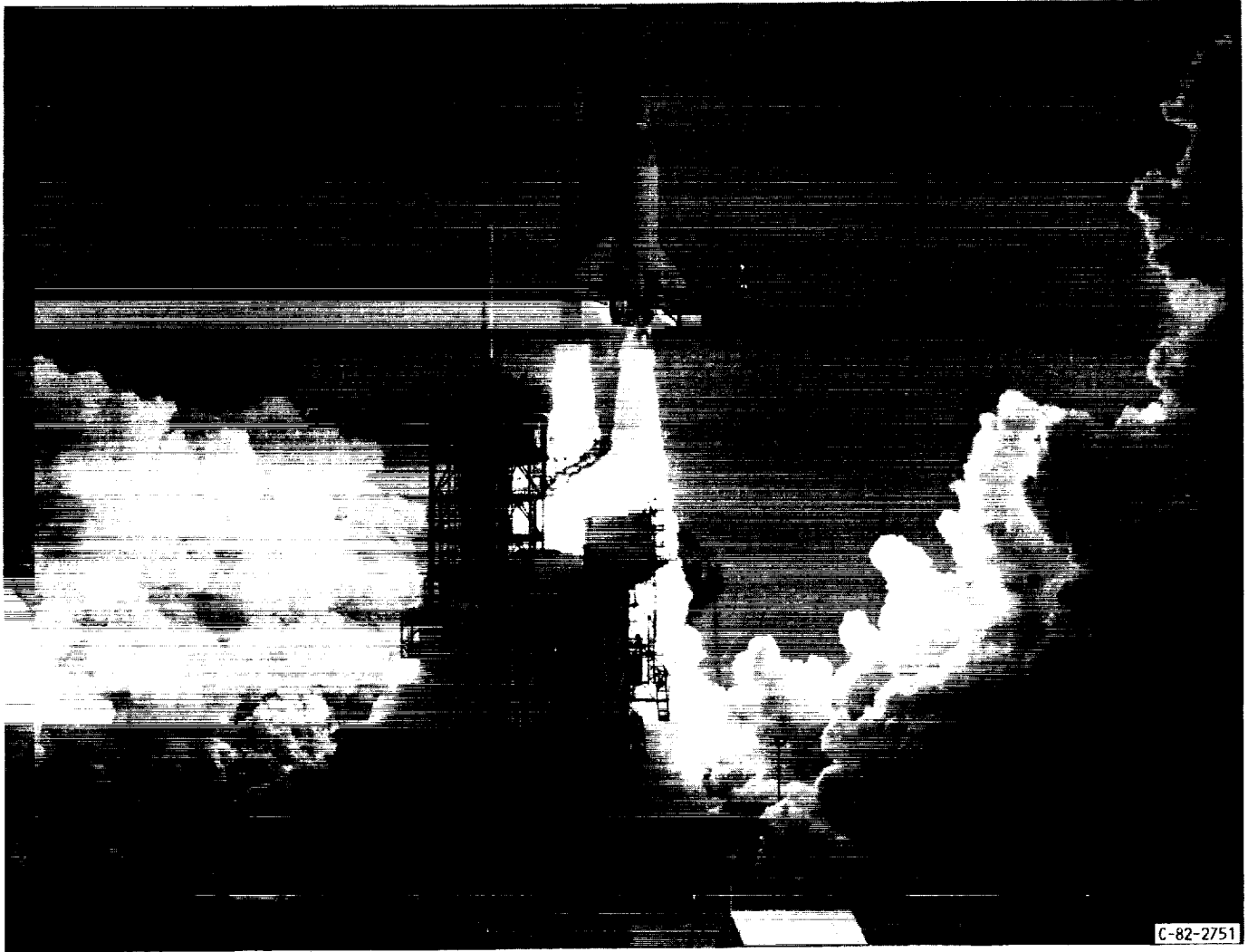
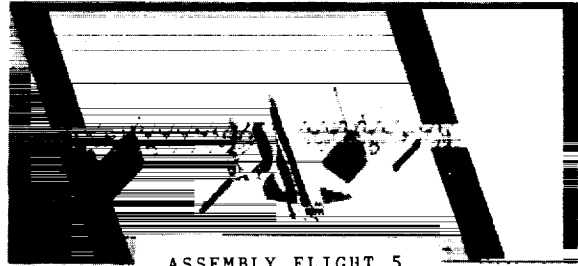

FIGURE 5. - NSTS DURING LIFTOFF.

ORIGINAL PAGE
BLACK AND WHITE PHOTOGRAPH



ASSEMBLY FLIGHT 1



ASSEMBLY FLIGHT 5
(MAN TENDED CAPABILITY)

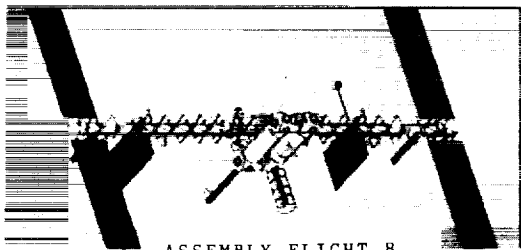

ASSEMBLY FLIGHT 8
(PERMANENTLY MANNED CAPABILITY)

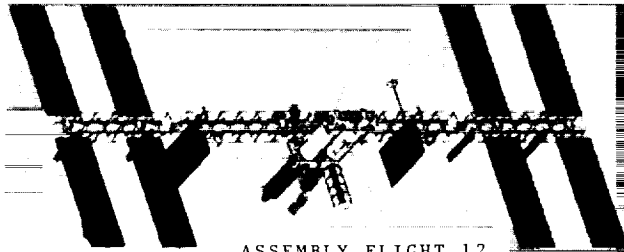

ASSEMBLY FLIGHT 12
(PHASE ONE CAPABILITY)

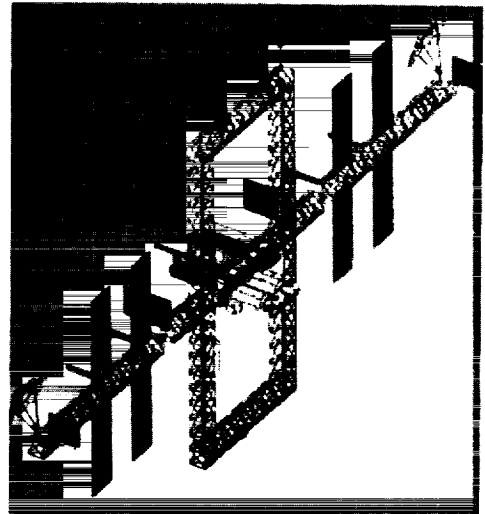

ASSEMBLY FLIGHT 16
(PHASE TWO CAPABILITY)

C-89-05938

NASA HQ SR7516-1
OSSTT 91
6 11-87

FIGURE 6. - SEVERAL KEY SPACE STATION ASSEMBLIES.

SPACE STATION PLAN PHASE I

ESA

- ELEMENTS
- PRESSURIZED LABORATORY MODULE
 - POLAR PLATFORM
 - MANNED-TENDED FREE FLYER (MTFF)

JAPAN

- ELEMENTS
- PRESSURIZED LABORATORY MODULE & EXPOSED FACILITY
 - EXPERIMENT LOGISTICS MODULE

NASA/GODDARD (Maryland)

- ELEMENTS:
- POLAR PLATFORM
 - ATTACHED PAYLOAD ACCOM (?)
 - TELEROBOTIC SERVICER

NASA/JOHNSON (Texas)

- ELEMENTS:
- TRUSS
 - MOBILE TRANSPORTER (PHASE I)
 - AIRLOCKS
 - NODES (PRESSURE SHELL - MSFC)
- SYSTEMS:
- EXTERNAL THERMAL CONTROL
 - EVA
 - DATA MANAGEMENT
 - COMMUNICATIONS & TRACKING
 - GUIDANCE, NAVIGATION & CONTROL
 - PROPULSION (THRUSTER TD BY MSFC)
 - NSTS SS ATTACHMENT SYSTEMS

CANADA

- ELEMENTS:
- MOBILE SERVICING CENTER (PHASE I)

NASA/MARSHALL (Alabama)

- ELEMENTS
- PRESSURE SHELLS FOR NODES
 - LABORATORY MODULE
 - HABITATION MODULE (OUTFITTING TD BY JSC)
 - LOGISTICS MODULE (PRESS & UNPRESS)
- SYSTEMS
- ECLSS
 - INTERNAL THERMAL CONTROL
 - INTERNAL AUDIO & VIDEO

NASA/LEWIS (Ohio)

- ELEMENTS:
- POWER MODULES - PV SYSTEM
 - ELECTRICAL POWER DISTRIBUTION

C-89-05939

FIGURE 7. - PHASE ONE SPACE STATION ELEMENTS.

ORIGINAL PAGE
BLACK AND WHITE PHOTOGRAPH

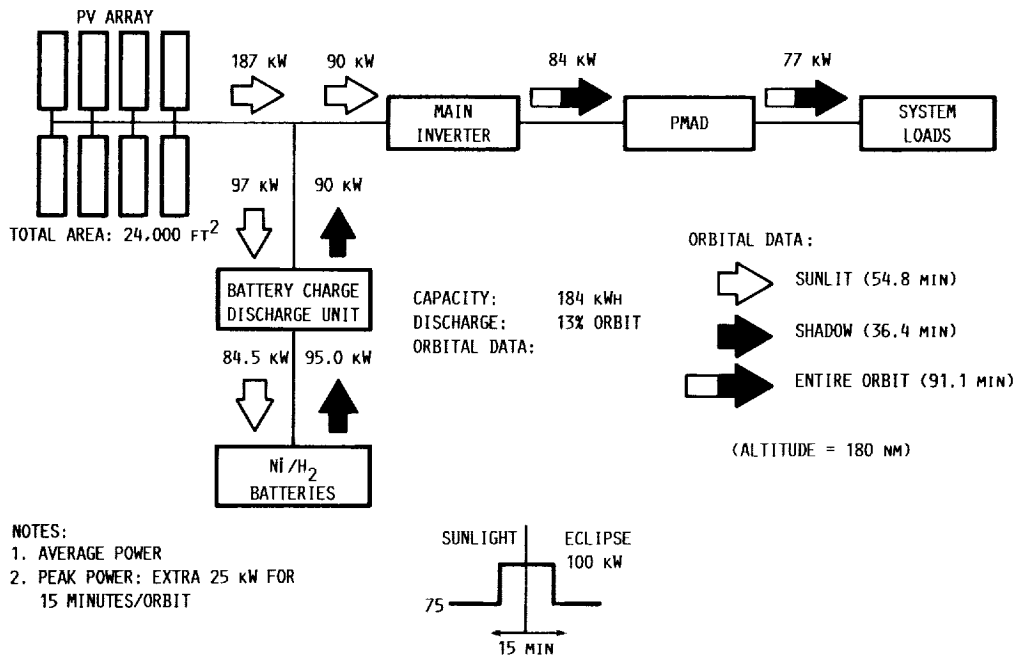

FIGURE 8. - SPACE STATION ELECTRIC POWER SYSTEM BLOCK DIAGRAM.

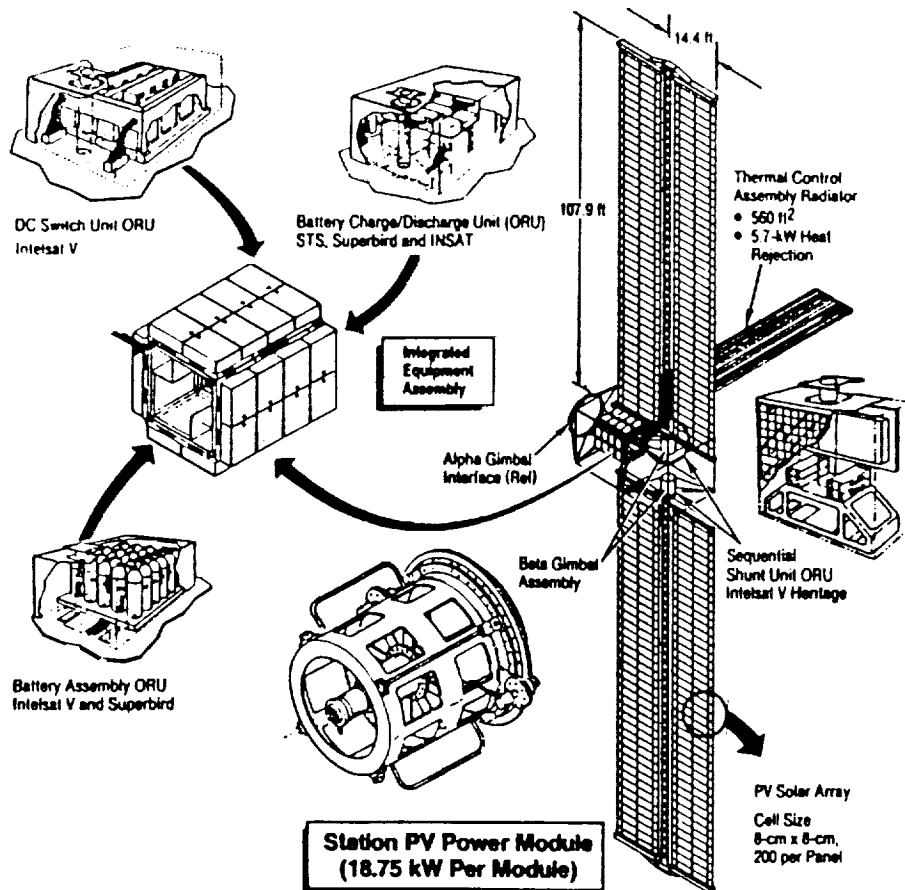

Figure 9. - Photovoltaic power module.

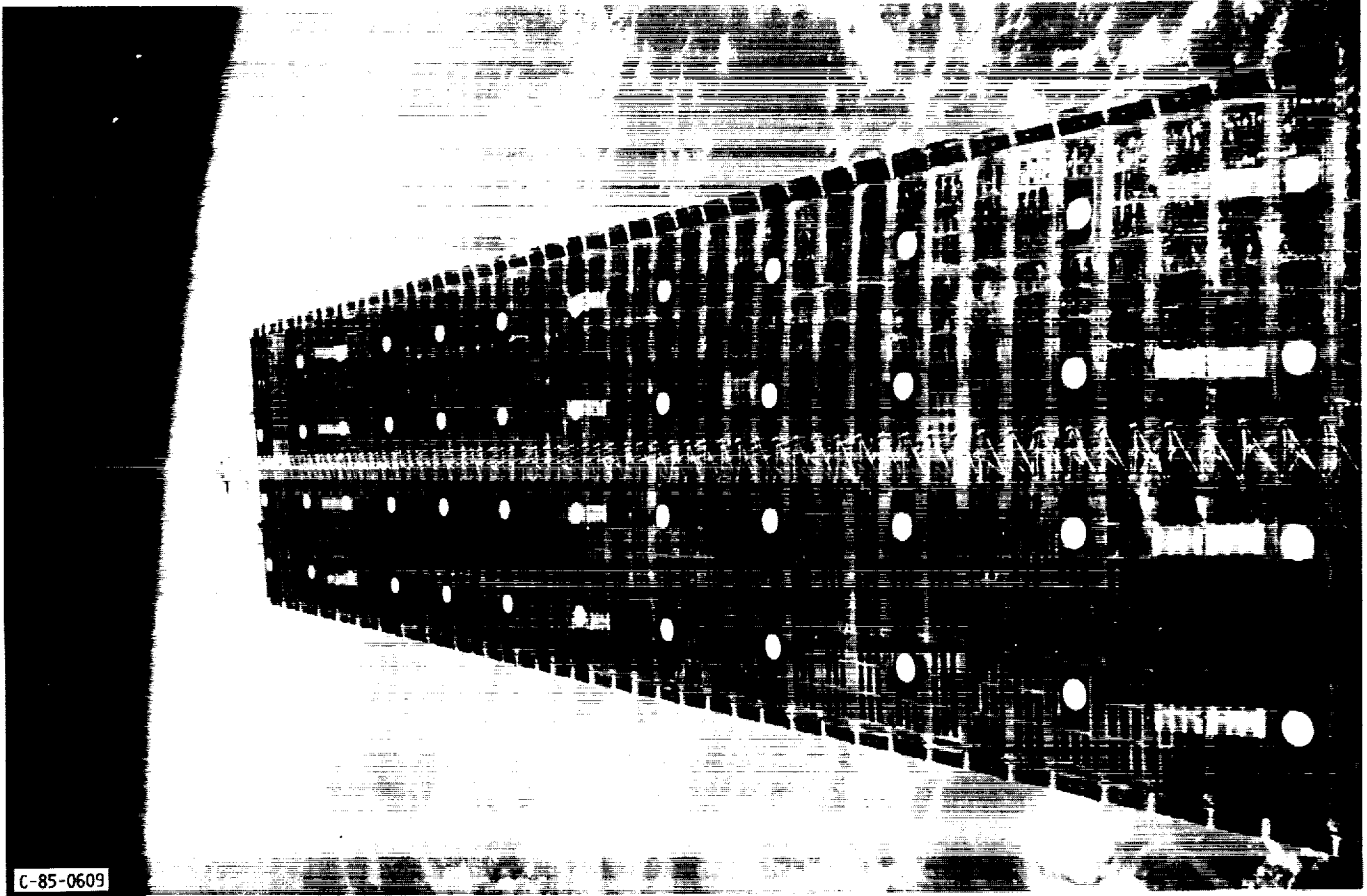

FIGURE 10. - SOLAR ARRAY FLIGHT EXPERIMENT.

ORIGINAL PAGE
BLACK AND WHITE PHOTOGRAPH

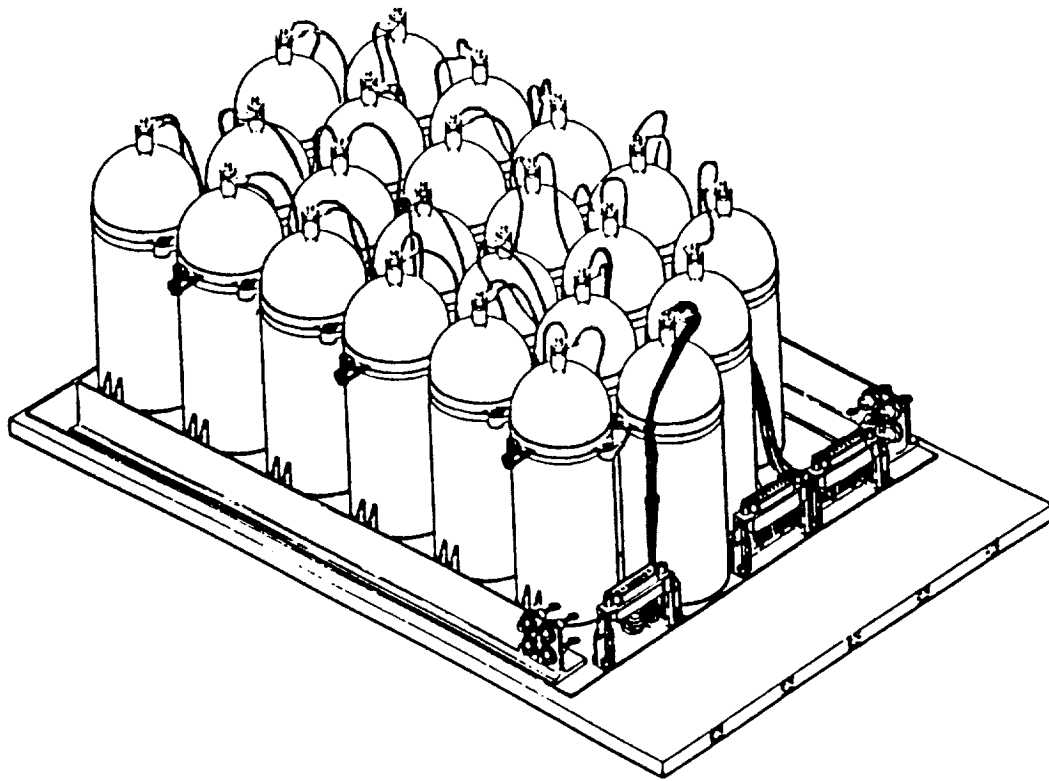

Figure 11. - Representative Ni-H₂ battery.

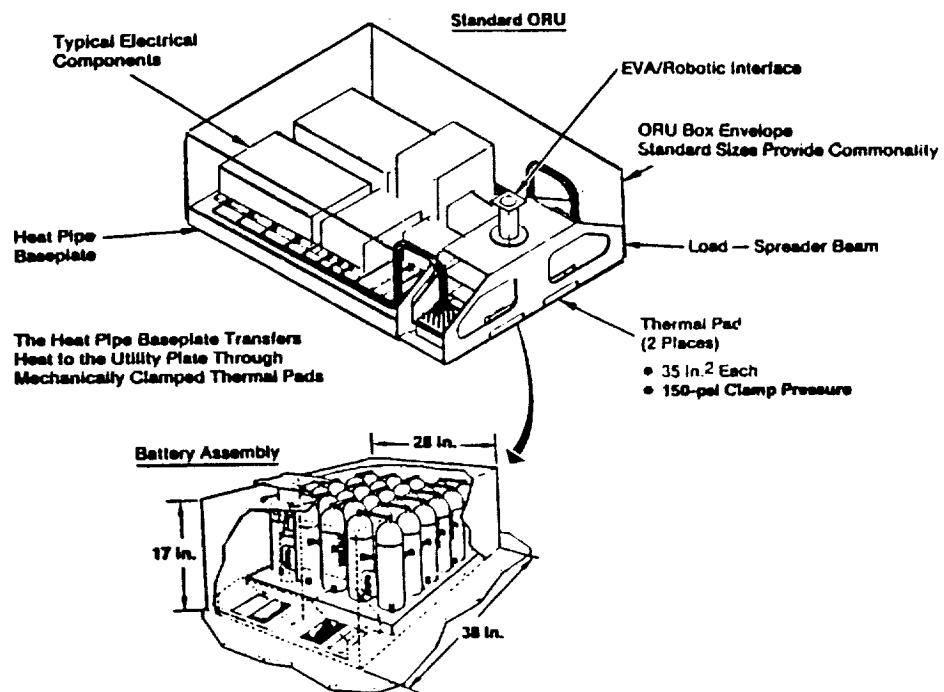

Figure 12. - Standard orbital replacement units (ORUs).

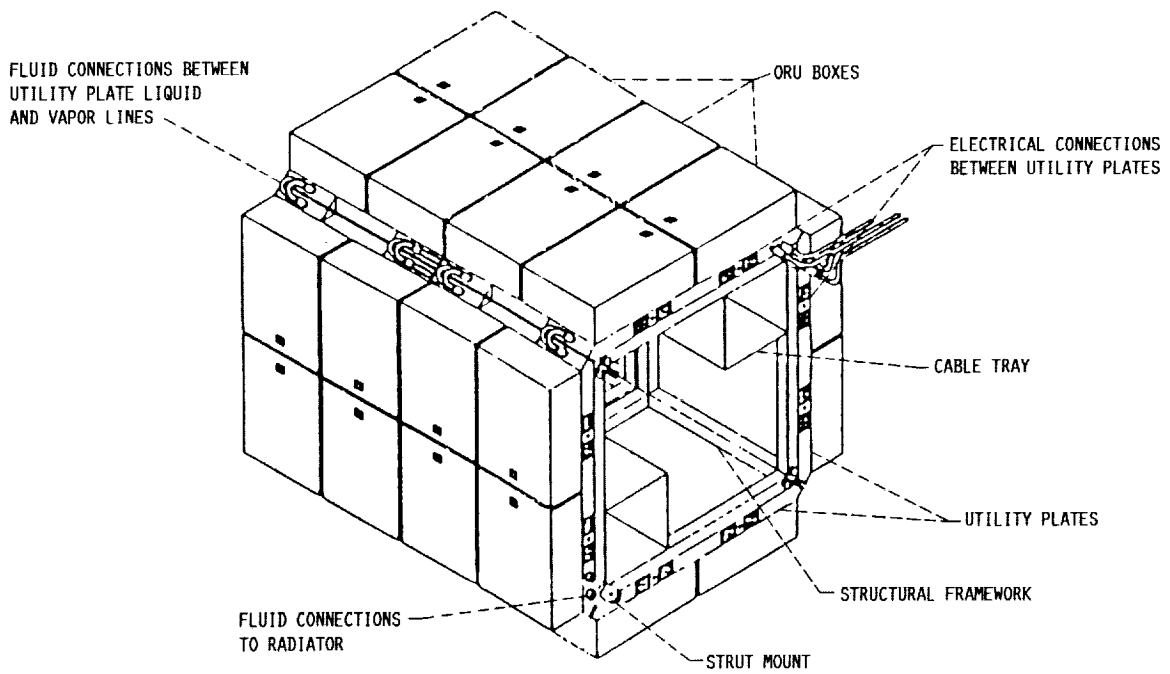

FIGURE 13. - INTEGRATED EQUIPMENT ASSEMBLY.

ORIGINAL PAGE
BLACK AND WHITE PHOTOGRAPH



C-87-3652

FIGURE 14. - 25KW 20 KHz TESTBED.

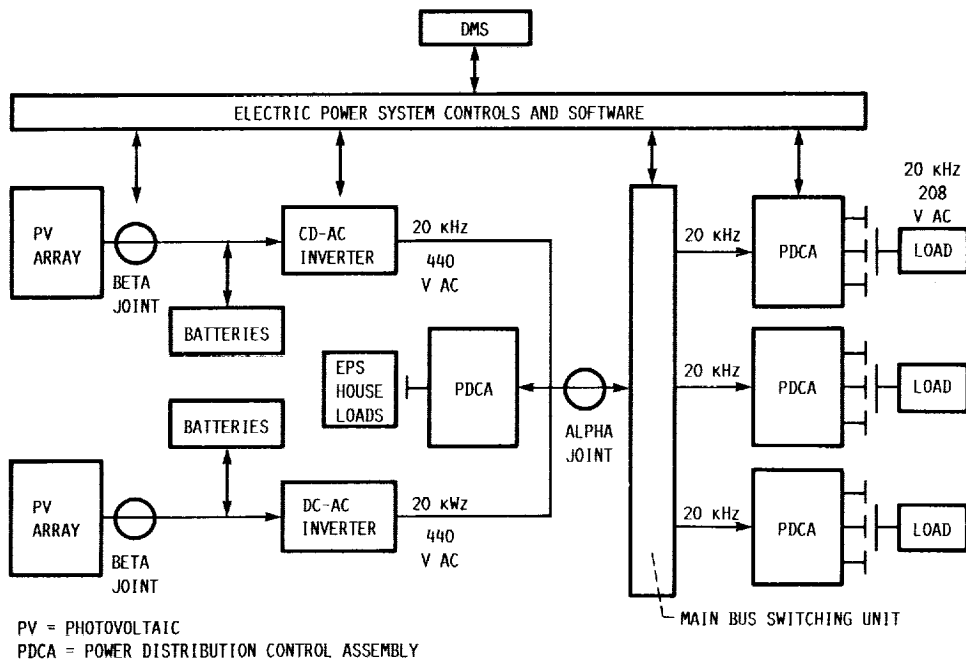

FIGURE 15. - PHASE ONE ELECTRIC POWER SYSTEM ARCHITECTURE.

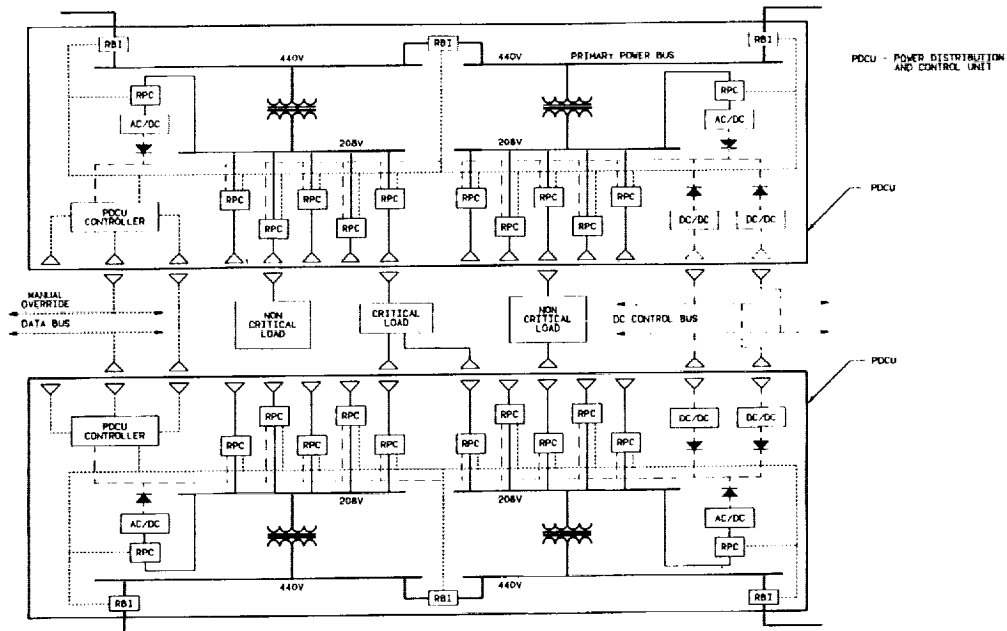

FIGURE 16. - POWER DISTRIBUTION AND CONTROL ASSEMBLY (PDCA).

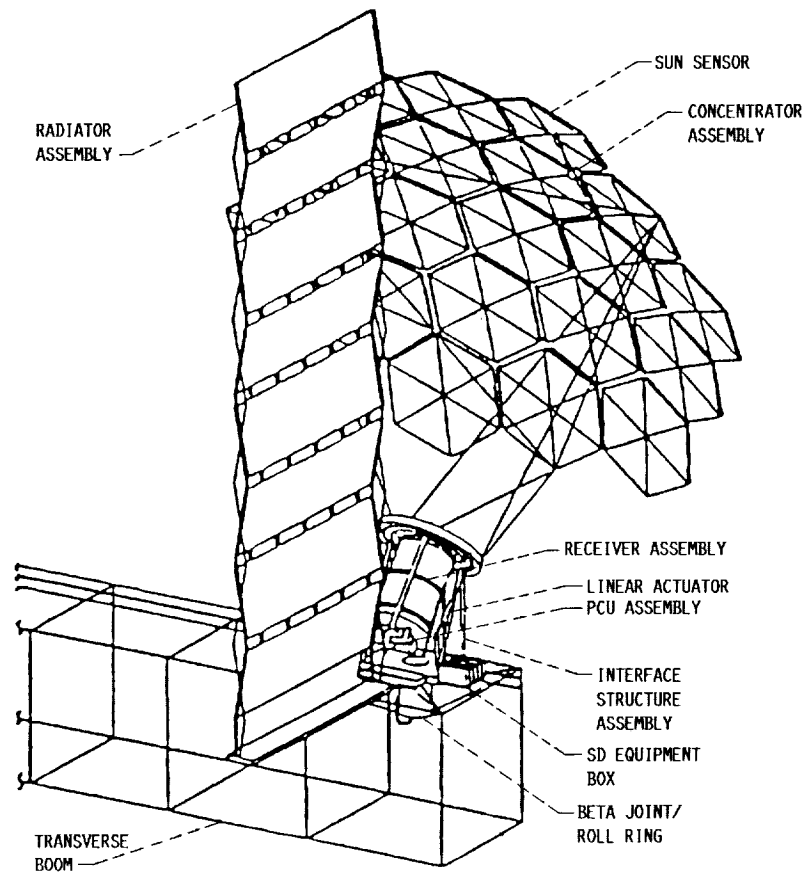

FIGURE 17. - SOLAR DYNAMIC POWER MODULE.

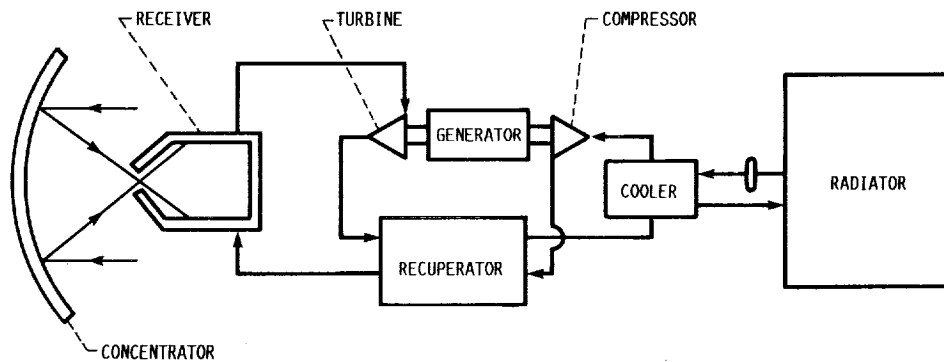

FIGURE 18. - SOLAR DYNAMIC SCHEMATIC.

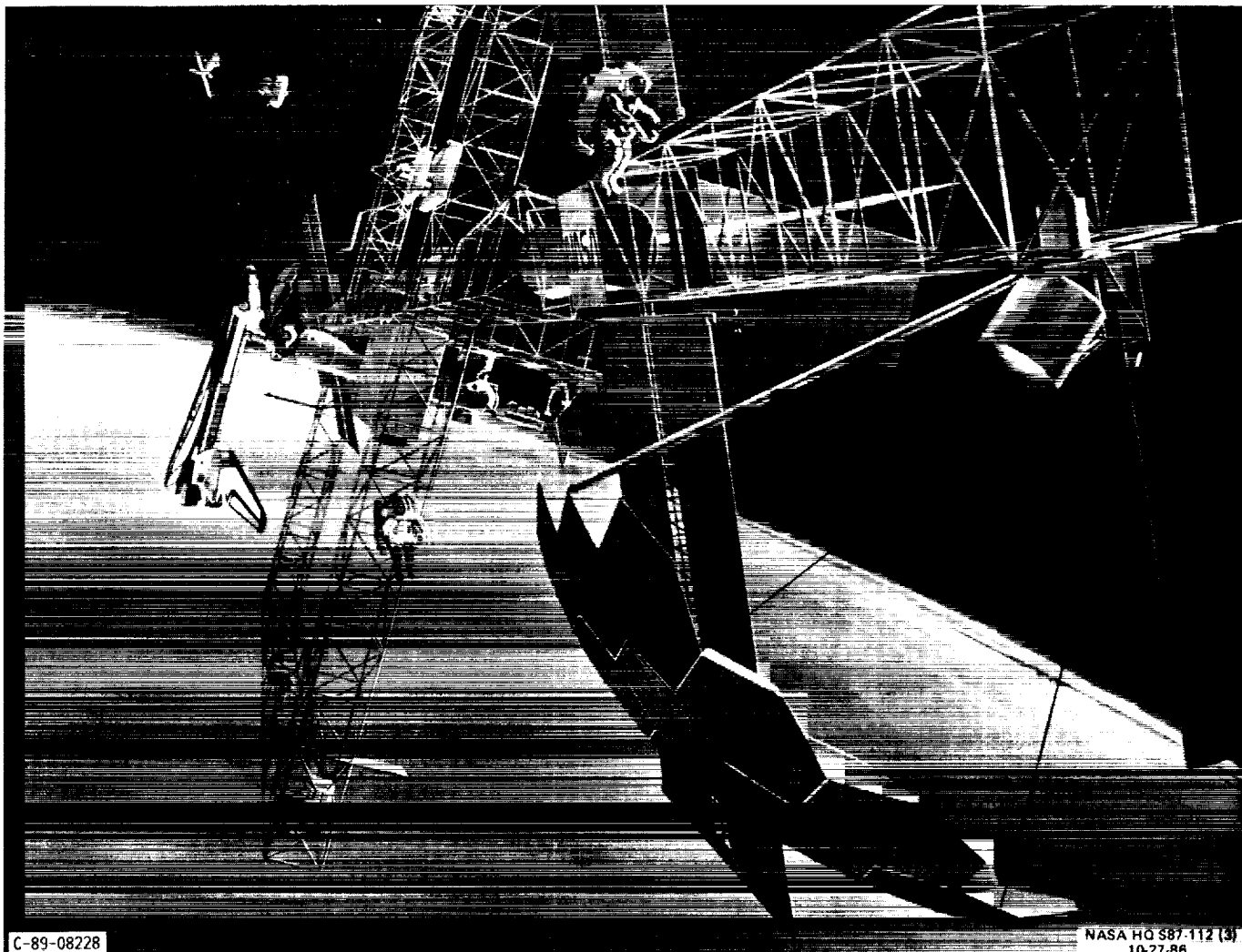

FIGURE 19. - 25KW CLOSED BRAYTON CYCLE SOLAR DYNAMIC MODULE.

ORIGINAL PAGE
BLACK AND WHITE PHOTOGRAPH

1. Report No. NASA TM-101974		2. Government Accession No.		3. Recipient's Catalog No.	
4. Title and Subtitle The U.S. Space Station and Its Electric Power System				5. Report Date	
				6. Performing Organization Code	
7. Author(s) Ronald L. Thomas				8. Performing Organization Report No. E-4674	
				10. Work Unit No. 474-11-10	
9. Performing Organization Name and Address National Aeronautics and Space Administration Lewis Research Center Cleveland, Ohio 44135-3191				11. Contract or Grant No.	
				13. Type of Report and Period Covered Technical Memorandum	
12. Sponsoring Agency Name and Address National Aeronautics and Space Administration Washington, D.C. 20546-0001				14. Sponsoring Agency Code	
15. Supplementary Notes Presented at The Tenth South Pacific Electrical International Convention sponsored by the Electrical Development Association of Queensland Inc., Brisbane, Queensland, Australia, May 2-5, 1988.					
16. Abstract <p>The United States has embarked on a major development program to have a space station operating in low earth orbit by the mid-1990's. This endeavor is a multi-billion dollar effort that draws on the talents of the NASA and most of the aerospace firms in the U.S. Plans are being pursued to include the participation of Canada, Japan and the European Space Agency in the space station. From the start of the program there has been a focus on the utilization of the space station for science, technology and commercial endeavors. These requirements have been utilized in the design of the station and manifest themselves in: pressurized volume; crew time; power availability and level of power; external payload accommodations; microgravity levels; servicing facilities; and the ability to grow and evolve the space station to meet future needs. President Reagan directed NASA to develop a permanently manned space station in his 1984 State of the Union message. Since then the definition phase has been completed and the development phase initiated. A major subsystem of the space station is its 75 kW electric power system. The electric power system has characteristics similar to those of terrestrial power systems. Routine maintenance and replacement of failed equipment must be accomplished safely and easily and in a minimum time while providing reliable power to users. Because of the very high value placed on crew time it is essential that the power system operate in an autonomous mode to minimize crew time required. The power system design must also easily accommodate growth as the power demands by users are expected to grow. This paper provides an overview of the U.S. space station with special emphasis on its electrical power system.</p>					
17. Key Words (Suggested by Author(s)) Space station; Electric power; Space power; Solar arrays; Batteries; Power management and distribution			18. Distribution Statement Unclassified - Unlimited Subject Category 20		
19. Security Classif. (of this report) Unclassified		20. Security Classif. (of this page) Unclassified		21. No of pages 26	22. Price* A03

