

MOBILITY POWER FLOW ANALYSIS
OF AN L-SHAPED PLATE STRUCTURE
SUBJECTED TO ACOUSTIC EXCITATION

NAG1-685

J.M. Cuschieri
Center for Acoustics and Vibration
Department of Ocean Engineering
Florida Atlantic University
Boca Raton, Florida 33431

December 1989

Progress Report
Grant Number NAG-1-685

Submitted to
NASA Langley Research Center
Hampton Virginia 23665

Foreward

This report describes the work done during most of 1989 under research Grant, Number NAG-1-685, entitled "Use of Energy Accountancy and Power Flow Techniques for Aircraft Noise Transmission". The main emphasis of this report is on the use of the mobility power flow approach to deal with the fluid structure interaction problem. In conformity with previous reports, a case study of an L-shaped plate will be considered to demonstrate the approach. This report is for the period between June 1989 to December 1989. During this period one Master's thesis has been finished and will be defended the first week of January 1990. The topic of this finished thesis is the derivation of the mobility power flow approach for the case of acoustic excitation including scatter. A second Master's thesis which addresses the experimental side of the acoustic excitation problem is in the final stages and will be finished the first quarter of 1990. This is the seventh in this series of progress reports under this research grant.

The author would like to acknowledge the graduate students who participated in this research work, the Department of Ocean Engineering and most important the financial support from the Structural Acoustics Division of the NASA Langley Research Center.

Submitted by



J.M. Cuschieri
Principal Investigator

ABSTRACT

An analytical investigation based on the Mobility Power Flow method is presented for the determination of the vibrational response and power flow for two coupled flat plate structures in an L-shaped configuration, subjected to acoustical excitation. The principle of the mobility power flow method consists of dividing the global structure into a series of subsystems coupled together using mobility functions. Each separate subsystem is analyzed independently to determine the structural mobility functions for the junction and excitation locations. The mobility functions, together with the characteristics of the junction between the subsystems, are then used to determine the response of the global structure and the power flow. In the coupled plate structure considered here, mobility power flow expressions are derived for excitation by an incident acoustic plane wave. In this case the forces (acoustic pressures) acting on the structure are dependent on the response of the structure because of the scattered pressure component. The interaction between the structure and the fluid leads to the derivation of a corrected mode shape for the plates' normal surface velocity and also for the structure mobility functions. The determination of the scattered pressure components in the expressions for the power flow represents an additional component in the power flow balance for the source plate and the receiver plate. This component represents the radiated acoustical power from the plate structure.

INTRODUCTION

Mobility Power Flow (MPF) methods [1-4] have been shown previously to provide an effective structure analysis tool to deal with the response of one and two dimensional structures with direct mechanical excitation. Comparison of the MPF results with experimental results on a one dimensional structure [4], and with numerical (Finite Element Analysis (FEA)) [3] and statistical (Statistical Energy Analysis (SEA)) [4] results showed good agreement. Using the MPF method, the exchange of vibrational power between the substructures can be obtained for different structural wave components [5].

One limitation of past work [1-5] is that only excitation by direct point or distributed forces has been considered and that interaction with the surrounding medium has been neglected. In practical situations, distributed loads from acoustic excitation often apply on structures, where the influence of the surrounding medium may not be negligible. Therefore, the main objective of this study is to extend the MPF method to distributed excitation when the excitation is influenced by the structural response (acoustic excitation). To be consistent with previous work the structure that will be considered in the analysis is an L-shaped plate, with an acoustic wave incident on one side of one of the flat plate substructures.

In using the MPF, the structure is modeled by a series of coupled substructures with each substructure analyzed independently. The coupling between the substructures is defined through the boundary conditions at the junctions, taking into account the forces and moments that the substructures exert on each other. Expressions for the input power to a substructure and for the transferred power between the substructures, are obtained in terms of the input and junction velocity contributions and the forces and moments that are applied on the substructures.

With direct force excitation of the structure, the input and transferred power can be written in terms of the input and transfer structural mobility functions of the substructures [2]. These only depend on the geometry of the specific substructure and on the frequency of excitation. The solution for the response of the global structure can be presented in a matrix form, which allows the method to deal with a large number of connected substructures. One advantage of dividing the global structure into subsystems is that, if the dependence of the response of the global structure on one of the subsystems is required, it is not necessary to repeat the whole of the analysis for the global structure, but only for that part that deals with the modified subsystem. Furthermore, the analysis is efficient to implement if the subsystem elements are identical, in which

case the independent response of only a typical subsystem is required.

Having defined the approach for a distributed mechanical excitation in a past report [6], the analysis is extended here to deal with the acoustic excitation of the structure. A harmonic plane acoustic wave is assumed to be incident on one side of one of the flat plate substructures. With acoustic excitation, the effects of fluid loading may not be negligible. The scattered pressure will interfere with the incident pressure field and the mode shape of the structure will be influenced by the presence of the fluid. The fluid that will be considered here is air and therefore approximations applicable for light fluid loading can be applied.

ACOUSTIC EXCITATION

Consider a structure in the plane $(x,y,0)$, with an acoustic fluid occupying the half-space $z > 0$. A plane wave incident on the surface of this structure can be described by:

$$p_i(x,y,z) = P_0 e^{-jk_x c \cos \theta \sin \phi} e^{-jk_y \sin \theta \sin \phi} e^{kz \cos \phi} \quad 1.$$

The direction of the plane wave incident on the surface of the structure subtends an angle ϕ to the normal of the plate and an angle θ to the x-axis direction in the plane of the structure (figure 1). This acoustic wave, incident on the surface of the structure represents the excitation and the structure is set in motion. The motion of the structure creates an acoustic field which interact with the incident field. Thus, the total pressure acting on the structure surface is modified due to the presence of the scattered acoustic pressure component. The total pressure acting on the surface of the structure can be represented by [7]:

$$p(x,y,z=0) = 2p_i(x,y,z=0) + p_s(x,y,z=0) \quad 2.$$

where $p_i(x,y,z=0)$ represents the incident pressure component and $p_s(x,y,z=0)$ represents the scattered pressure component. The factor of 2 in front of the incident pressure component is introduced to take into account the reflected pressure component which is equal and opposite in the z direction to the incident pressure component (twice $p_i(x,y,z=0)$ represents the blocked pressure component).

From equation (2) it can be observed that the scattered pressure component can be dealt with separate from the incident

pressure. If the structure has responses which are associated with different forces and moments acting on the structure, each of these responses creates a scattered pressure component. The total scattered pressure, thus has contributions from these different components and these can be dealt with separately.

In the case of the L-shaped plate, the scattered pressure from the source plate, the plate receiving the acoustic wave, has two components, one which can be associated with the acoustic excitation and another component which can be associated with the edge moment representing the influence of the attached receiver plate. Each of these components can be dealt with separately, provided the changes in the response of the structure due to the fluid loading are taken into account.

If the structure response mode shape is a priori known, the influence of the fluid loading on the structure can be directly determined from a solution of the coupled equations of motion [7]. However, this approach is not applicable when the mode function is not known. An alternative approach has been suggested by Leppington [8], where a solution for the response and scattered pressure are obtained based on an approximate solution for the case where the scattered pressure is not taken into account. The complete solution is given in terms of a correction factor, which is introduced to take into account the scattered pressure component and still satisfy the boundary conditions for the structure and the acoustic medium.

With the Leppington [8] approach, the solutions for the structure response and scattered pressure are obtained by first determining the influence of the fluid loading on the response of the structure. This influence is described by a correction factor applied to the response of the structure obtained when the fluid loading is neglected. This correcting factor is independent of the magnitude of the applied loading and is mainly controlled by the boundary conditions for the structure and the type of loading. From knowledge of the response, a scattered pressure is computed. This scattered pressure is used to determine the pressure loading on the surface of the structure and also the vibrational power input to the structure.

The above approach would directly fit into the MPF method, since with the MPF the global structure response is analyzed in terms of the separate responses of the subsystems representing the global structure. The scattered pressure components of each subsystem is thus separately determined and then summed to compute the power input to the global structure. That is, in this case of acoustic excitation of the L-shaped plate, the approach that will be followed would be to separately determine the response, including the correction factor, for each of the two plate subsystems, one representing a simply supported plate with an incident acoustic wave and the second representing a

simply supported plate with an edge moment. Then after having determined these corrected mobility functions, the total response of the structure and the scattered pressure components are computed. The power flow components are then determined from these results. The solutions for the two subsystems of the L-shaped plate follow in the next sections.

SIMPLY SUPPORTED FLATE SUBJECTED TO AN INCIDENT SOUND FIELD

The equation of motion for the transverse displacement of a plate is given by:

$$D_p \nabla^4 W(x,y) - \rho \omega W(x,y) = p(x,y,z=0) \quad 3.$$

where $p(x,y,z=0)$ represents the pressure loading the plate. This term consists of the incident pressure component plus the scattered pressure component (equation 2).

Assuming a sinusoidal mode shape in the x direction [2], the direction parallel to the junction, the displacement $W(x,y)$ can be written in the form,

$$W(x,y) = \sum_{m=1}^{\infty} W_m(y) \sin\left(\frac{m\pi x}{a}\right) \quad 4.$$

Substituting this equation into equation (3),

$$\left(\frac{m\pi}{a}\right)^4 W(y) - 2\left(\frac{m\pi}{a}\right)^2 \frac{\partial^2 W(y)}{\partial y^2} + \frac{\partial^4 W(y)}{\partial y^4} - k_p^4 W(y) = \frac{p(y)}{D_p} \quad 5.$$

where the subscript m is dropped for simplicity, k_p is the plate wavenumber and $p(y)$ is defined by

$$p(y) = \frac{2}{a} \int_0^a p(x,y) \sin\left(\frac{m\pi x}{a}\right) dx \quad 6.$$

Applying equation (6) to the incident pressure, given by equation (1),

$$p_i(y) = \frac{2P_o}{a} I_1 e^{(-jkysin\theta\sin\phi)} \quad 7.$$

where

$$I_1 = \frac{m\pi}{a} \frac{(-1)^m e^{(-jkacos\theta\sin\phi)}}{(k\cos\theta\sin\phi)^2 - (m\pi/a)^2} \quad 8.$$

The scattered pressure component for mode m is a function of the normal surface velocity and is therefore dependent on the solution for the response of the plate. That is, a coupled solution for the plate and the scattered pressure is required. If the scattered pressure component is neglected, the right hand-side of equation (5) has only one component, given by equation (7) multiplied by a factor of 2. In this case the solution for the displacement of the plate can be written in the form:

$$W(y) = W_g(y) + W_h(y) \quad 9.$$

where $W_g(y)$ is the particular solution of equation (5),

$$W_g(y) = \frac{4P_o}{a} \frac{I_1}{D_p} \frac{e^{(-jkysin\theta\sin\phi)}}{\left[(m\pi/a)^2 + (k\sin\theta\sin\phi)^2 \right]^2 - k_p^4} \quad 10.$$

and $W_h(y)$ is the solution of the homogeneous equation of motion,

$$W_h(y) = A\cosh(k_1y) + B\sinh(k_1y) + C\cos(k_2y) + D\sin(k_2y) \quad 11.$$

where k_1 and k_2 are defined by

$$k_1^2 = 2k_x^2 + k_y^2$$

$$k_2 = k_y$$

$$k_x = m\pi/a$$

$$k_y^2 = \omega \sqrt{\frac{\rho}{D_p}} - k_x^2$$

12.

The coefficients A, B, C and D in equation (11) are selected to satisfy the boundary conditions in the y direction. In the case of the simply supported plate these boundary conditions are:

$$W(y=0) = 0 \quad ; \quad \frac{\partial^2 W(y=0)}{\partial y^2} = 0$$

$$W(y=b) = 0 \quad ; \quad \frac{\partial^2 W(y=b)}{\partial y^2} = 0$$

13.

Solving for A, B, C and D using these boundary conditions will yield

$$\begin{aligned}
A &= - \frac{W_g''(0) + W_g(0)k_2^2}{2k_p^2} \\
B &= \frac{-k_2^2 W_g(b) - W_g''(b) + [W_g''(0) - W_g(0)k_2^2] \cosh(k_1 b)}{2k_p^2 \sinh(k_1 b)} \\
C &= \frac{W_g''(0) - W_g(0)k_1^2}{2k_p^2} \\
D &= \frac{-k_1^2 W_g(b) + W_g''(b) - [W_g''(0) - W_g(0)k_1^2] \cos(k_2 b)}{2k_p^2 \sin(k_2 b)}
\end{aligned}$$

14.

where the double prime indicates a second derivative with respect to y .

To compensate for neglecting the scattered pressure component, a corrective complex coefficient K_I is introduced [8]

$$W_1(y) = W_g(y) + K_I W_h(y) \quad 15.$$

The main influence of the scattered pressure component will be on the contribution from the solution to the homogenous equation of motion [8]. This is the reason why the correction factor K is only applied to the term $W_h(y)$. This complex correction coefficient K will be close to unity away from the resonant frequencies and will deviate from unity at the resonant frequencies where the influence of the fluid on the velocity mode shape is most significant [8]. If $W_1(y)$ represents the exact solution for the response of the simply supported plate to the acoustic excitation, then the approximate result obtained when neglecting the scattered pressure component introduces an error $W_e(y)$ given by

$$W_e(y) = W(y) - W_1(y) \quad 16.$$

By substituting the above equation into the equation of motion (equation 5), the error term $W_e(y)$ must satisfy the differential equation,

$$\left(\frac{m\pi}{a}\right)^4 W_e(y) - 2\left(\frac{m\pi}{a}\right)^2 \frac{\partial^2 W_e(y)}{\partial y^2} + \frac{\partial^4 W_e(y)}{\partial y^4} - k_p^4 W_e(y) = \frac{P_s(y)}{D_p}$$

17.

In solving equation (17), a set of boundary conditions that apply to $W_e(y)$ can be derived from the boundary conditions for $W(y)$.

$$W_e(y=0 \text{ or } b) = -W_1(y=0 \text{ or } b) = -(W_g(0 \text{ or } b) + K_I W_h(0 \text{ or } b)) = 0$$

$$\frac{\partial W_e^2(y=0 \text{ or } b)}{\partial y^2} = -\frac{\partial W_1^2(y=0 \text{ or } b)}{\partial y^2} = -\left[\frac{\partial W_g^2(y=0 \text{ or } b)}{\partial y^2} + K_I \frac{\partial W_h^2(y=0 \text{ or } b)}{\partial y^2}\right] = 0$$

18.

A solution for $W_e(y)$ is derived in terms of the Green function $G(\xi, y)$ for the structure [8]

$$W_e(y) = \frac{1}{D_p} \int_0^b G(\xi, y) P_s(\xi) d\xi + G'(b, y) W_e''(b) - G'(0, y) W_e''(0) + G'''(b, y) W_e''(b) - G'''(0, y) W_e''(0) - 2(m\pi/a) \left[G'(b, y) W_e(b) - G'(0, y) W_e(0) \right]$$

19.

where the primes for the function G represent derivatives with respect to ξ . The function $G(\xi, y)$ is defined by:

$$G(\xi, y) = \frac{2}{b} \sum_{n=1}^{\infty} \frac{\sin\left(\frac{n\pi\xi}{b}\right) \sin\left(\frac{n\pi y}{b}\right)}{k_p^4 - \left[\left(\frac{m\pi}{a}\right)^2 + \left(\frac{n\pi}{b}\right)^2 \right]^2} \quad 20.$$

From the expression for $W_e(y)$, the coefficient K is selected such that $W_e(y) = 0$ for all values of y . Substituting equation (20) into equation (19), and equating $W_e(y)$ to zero, an expression is obtained that contains $p_s(\xi)$, which is still an unknown. However, $p_s(\xi)$ can be expressed as a function of the normal displacement of the plate, by using the momentum equation. Introducing this substitution and after some manipulations which are presented in the appendix, the following result is obtained for $p_s(\xi)$

$$\frac{1}{D_p} \int_0^b p_s(\xi) \sin(k_2 \xi) d\xi = \frac{1}{2\pi^2 a} \left[\frac{m\pi}{a} \right]^2 \alpha_1 \int_{-\infty}^{\infty} W_1(\beta) I(\beta) S(\beta) d\beta \quad 21.$$

where α_1 is the fluid loading coefficient defined by:

$$\alpha_1 = (\omega \rho_0) / D_p, \quad 22.$$

ρ_0 is the fluid density, and β is the spatial Fourier transform variable in the Y direction. $I(\beta)$ and $S(\beta)$ are defined in the appendix. From equations (15), (18), (19) and (21) an expression for the correcting coefficient K_I is derived,

$$K_I = \frac{\frac{-j}{2\pi^2 a} \left(\frac{m\pi}{a}\right)^2 \alpha_1 \int_{-\infty}^{\infty} W_g(\beta) I(\beta) S(\beta) d\beta + \text{RES}}{\frac{-j}{2\pi^2 a} \left(\frac{m\pi}{a}\right)^2 \alpha_1 \int_{-\infty}^{\infty} W_h(\beta) I(\beta) S(\beta) d\beta + \text{RES}} \quad 23.$$

where

$$\text{RES} = k_2 \cos(k_2 b) W_g''(b) - k_2 W_g''(0) - k_1^2 k_2 \cos(k_2 b) W_g(b) + k_1^2 k_2 W_g(0) \quad 24.$$

Having solved for the response of the simple supported plate a modal mobility function can be defined by the ratio of the modal velocity response to the input incident pressure. That is, using the same notation as in previous reports, with the subscript 1 indicating the input excitation location, the input modal mobility for mode m is given by,

$$M_{1m}(y) = \frac{j\omega W_1(y)}{P_o} = \frac{j\omega 4I_1}{aD_p} \frac{e^{-jk_1 y}}{\Xi} + j\omega K_I \left[A' \cosh(k_1 y) + B' \sinh(k_1 y) + C' \cos(k_2 y) + D' \sin(k_2 y) \right] \quad 25.$$

where

$$k_a = k \sin \theta \sin \phi \quad 26.$$

$$A' = \frac{2 I_1}{a D_p k_p^2} \frac{\left[k_2^2 - k_a^2 \right]}{\Xi} \quad 27.$$

$$B' = \frac{2 I_1}{a D_p k_p^2} \left[\frac{(k_a^2 - k_2^2) e^{-jk_{ab}} - (k_a^2 + k_2^2) \cosh(k_1 b)}{\Xi \sinh(k_1 b)} \right] \quad 28.$$

$$C' = \frac{-2 I_1}{a D_p k_p^2} \frac{\left[k_1^2 + k_a^2 \right]}{\Xi} \quad 29.$$

$$D' = \frac{2 I_1}{a D_p k_p^2} \left[\frac{-(k_a^2 + k_1^2) e^{-jk_{ab}} + (k_a^2 + k_1^2) \cos(k_2 b)}{\Xi \sin(k_2 b)} \right] \quad 30.$$

$$\Xi = \left[\left(\frac{m\pi}{a} \right)^2 + k_a^2 \right]^2 - k_p^4 \quad 31.$$

Similarly, a modal transfer mobility function, defined by the ratio of the edge rotational velocity per unit incident pressure, can be derived from the above solution for the response. If the subscript 2 represents the location of the junction, the modal transfer mobility for mode m is given by,

$$\begin{aligned}
M_{21m} &= \frac{j\omega}{P_o} \frac{\partial W_1(y=b)}{\partial y} \\
&= \frac{\omega^4 I_1}{a D_p} \frac{k_a e^{-jk_a b}}{\Xi} + j\omega K_I \left[A' k_1 \sinh(k_1 b) + \right. \\
&\quad \left. B' k_1 \cosh(k_1 b) - C' k_2 \sin(k_2 b) + D' k_2 \cos(k_2 b) \right]
\end{aligned}$$

32.

One can observe that for these two mobility functions the input mobility is a function of both the mode number and the variable y while the transfer mobility is a function of only the mode number. The reason for the y dependency for the input mobility is because the excitation is distributed over the surface of the plate structure and thus this input mobility represents the response per unit incident pressure anywhere on the surface of the plate structure.

SIMPLY SUPPORTED PLATE WITH AN EDGE MOMENT

An approach similar to the one used for the subsystem discussed in the previous section will be used for this second subsystem. In this case there is no incident acoustic waves, that is $p_i(x,y,z) = 0$. The forces acting on this subsystem are the edge moment and the scattered pressure. Therefore the same equation of motion as equation (5) applies with the pressure term on the right hand side only representing the scattered pressure. Because of the presence of the edge moment, the boundary conditions for the edge $y=b$ of this plate subsystem are different from those given in equation (13). The boundary conditions for the edge $y=b$ in this case are given by,

$$W(y=b) = 0 ; \quad \frac{\partial^2 W(y=b)}{\partial y^2} = - \frac{T_m}{D_p}$$

33.

where T_m represents the mode m component of the edge moment [2]. the response in this case is obtained by solving the equation of motion as given by equation (5), with $p(x,y,z=0)$ replaced by the scattered pressure component. In obtaining a solution to this

equation of motion, a first approximation is obtained by neglecting the scattered pressure, in which case it becomes a homogeneous equation of motion. The solution that satisfies the boundary conditions is given by,

$$W_h(y) = W(y) = \frac{T_m}{2\sqrt{\rho D_p} \omega} \left[\frac{\sin(k_2 y)}{\sin(k_2 b)} - \frac{\sinh(k_1 y)}{\sinh(k_1 b)} \right] \quad 34.$$

To account for the presence of the scattered pressure component, a corrective factor K_{II} is introduced

$$W_1(y) = \frac{K_{II} T_m}{2\sqrt{\rho D_p} \omega} \left[\frac{\sin(k_2 y)}{\sin(k_2 b)} - \frac{\sinh(k_1 y)}{\sinh(k_1 b)} \right] \quad 35.$$

$W_1(y)$ represents the exact solution of the equation of motion including the scattered pressure. The error introduced by the approximation is again given by an equation of the form of equation (16) where in this case as well $W_e(y)$ must satisfy equation (17). However, the boundary conditions that apply to the term $W_e(y)$ in this case are different from those given in equation (18). The boundary conditions are modified to include the influence of the edge moment.

$$W_e(y=0 \text{ or } b) = -W_1(y=0 \text{ or } b) = -K_{II} W(0 \text{ or } b) = 0$$

$$\frac{\partial W_e^2(y=0)}{\partial y^2} = -\frac{\partial W_1^2(y=0)}{\partial y^2} = -K_{II} \frac{\partial W_h^2(y=0)}{\partial y^2} = 0$$

$$\frac{\partial W_e^2(y=b)}{\partial y^2} = -\frac{\partial W_1^2(y=b)}{\partial y^2} - \frac{T_m}{D_p} = -\frac{T_m}{D_p} (1 - K_{II})$$

36.

The solution for $W_e(y)$ is again derived in terms of the Green function (similar equations as (19) and (20)). The application of the boundary conditions into equation (19), and setting $W_e(y) = 0$ for all values of y leads to an equation involving $p_s(y)$,

$$\frac{1}{D_p} \left[\int_0^b p_s(\xi) \sin(k_2 \xi) d\xi - k_2 \cos(k_2 b) (1 - K_{II}) T_m \right] = 0 \quad 37.$$

Substituting for the integral in equation (37) by equation(21), an expression for the correction coefficient K_{II} is obtained as follows,

$$K_{II} = \frac{k_2 \cos(k_2 b)}{k_2 \cos(k_2 b) + \frac{j}{2\pi^2 a} \left[\frac{m\pi}{a} \right]^2 \alpha_1 \int_{-\infty}^{\infty} W_h(\beta) I(\beta) S(\beta) d\beta}$$

38.

Having derived a solution for the response of the plate subsystem subjected to an edge moment and including the influence of the fluid loading on the plate, an input mobility function can be obtained for the edge of the plate. Defining an edge input mobility as the rotational velocity response per unit applied edge moment,

$$M_{2m} = \frac{j\omega}{T_m} \frac{\partial W(y=b)}{\partial y} = \frac{j K_{II}}{2\sqrt{\rho D_p}} \left[\frac{k_2}{\tan(k_2 b)} - \frac{k_1}{\tanh(k_1 b)} \right] \quad 39.$$

If the two plates of the L-shaped plate structure are identical then,

$$M_{2m} = M_{3m} \quad 40.$$

The subscript 3 represents the connected edge of the receiver plate [2].

A transfer mobility function for the plate surface velocity response per unit applied edge moment can also be defined from the above analysis,

$$M_{12}_m = \frac{jK_{II}}{2\sqrt{\rho D_p}} \left[\frac{\sin(k_2 y)}{\sin(k_2 b)} - \frac{\sinh(k_1 y)}{\sinh(k_1 b)} \right] \quad 41.$$

In this case as well the input mobility functions are only a function of the mode number m . However, the transfer mobility is a function of both the variable y and the mode number m , since it represents a transfer to any point on the surface of the plate.

INPUT AND TRANSFER POWER EQUATIONS

Having derived the mobility functions, the derivation of the power flow equations follows in the same way as was done for the mechanical excitation [2]. There are however some differences. One of the differences is that some of the mobility functions, apart from the modal dependency, also include a dependency on the spatial variable y . Since the excitation is a distributed load the input power must be obtained both as an integral over the spatial variable and as a summation over all the modes. The modal summation is an alternative way of performing a spatial integration when the response can be decomposed into a set of modes.

For the transferred power, this is given by an integral along the entire length of the junction or alternatively since this is the direction for which a modal decomposition has been assumed, as a summation over all the modes. Since the transferred power is dependent on the edge moment which is controlled by the incident acoustic excitation, to evaluate the edge moment and hence the transferred power an integral still has to be performed for the y direction, the direction perpendicular to the junction.

Power Input

The total input power is given by the product of the total pressure acting on the source plate surface and the plate velocity response integrated over the y direction and summed for all modes m .

$$P_{\text{input}} = \frac{a}{4} \sum_{m=1}^{\infty} \text{Real} \int_0^b \left[2p_i(y) + p_{s_1}(y) + p_{s_2}(y) \right] V_1^*(y) dy$$

42.

where the two p_s terms represent the scattered pressure components associated one with the response of the source plate due to the incident sound wave and one due to the application of the edge moment. V_1^* is the surface velocity of the source plate for mode m and is given by,

$$V_1(y) = P_o M_{1m}(y) + T_m M_{12m}(y)$$

43.

Eliminating T_m by solving for continuity of motion at the junction edge,

$$T_m M_{3m} - T_m M_{2m} = -T_m M_{2m} + P_o M_{21m}$$

$$T_m = \frac{P_o M_{21m}}{2 M_{2m}}$$

44.

substituting into equation (43),

$$V_1(y) = P_o \left[M_{1m}(y) + \frac{M_{21m}}{2M_{2m}} M_{12m}(y) \right]$$

45.

Substituting into the power input expressions the values for $V_1(y)$ and for the scattered pressure components the following result is obtained for the input power;

$$P_{\text{input}} = \frac{a}{4} \sum_{m=1}^{\infty} \left\{ \text{Real} \int_0^b 2p_i(y) P_o^* \left[M_{1m}(y) + \frac{M_{21m}}{2M_{2m}} M_{12m}(y) \right]^* dy \right. \\ \left. + P_o^2 \frac{\omega \rho_o}{4\pi^2} \left(\frac{m\pi}{a} \right)^2 \text{Real} \int_{-\infty}^{\infty} I(\beta) \left| M_{1m}(\beta) + \frac{M_{21m}}{2M_{2m}} M_{12m}(\beta) \right|^2 d\beta \right\}$$

46.

In the last integral of the above equation the variable y has been changed to the variable β which represents the fourier transform variable with respect to y . Also, this last integral represents the power flow out of the source plate, as radiated acoustical power.

Power Transfer

The transferred power between the two plates is given by the summation of all the mode contributions for the product between the edge moment and the edge rotational velocity. This can also be expressed in terms of the modal mobility functions derived above,

$$P_{\text{trans}} = \frac{a}{4} \sum_{m=1}^{\infty} P_o^2 \left| \frac{M_{21m}}{2M_{2m}} \right|^2 \text{Real} \left(M_{2m} \right) \quad 47.$$

RESULTS

Results for the power input, power transfer and radiated acoustical power are obtained using the above power flow expressions. The characteristics of the plate structure considered in the analysis are the same as those for previous analysis in this series. These characteristics are shown in figure (2).

Acoustic waves are considered incident on the source plate such that both θ and ϕ are equal to 45° . The results for the input and transferred power for this angle of incidence are shown in figure (3). Figure (4) shows the acoustic power radiated by the source plate obtained from the scattered pressure component. As can be observed from this figure the contribution to the scattered pressure from motion of the source plate due to the presence of the edge moment is not significant.

To determine the influence of the fluid loading on the power flow, the input and transferred power are computed when the fluid loading effects (both the scattered pressure and the coefficients K) are neglected. Figures (5) and (6) show a comparison between the two sets of results. As can be observed from these figures the influence of the fluid loading is not very significant, although some differences are observed mainly near the resonant frequencies and in the troughs between the resonant frequencies. The main influence of the fluid loading is to increase the damping of the structure due to the acoustic radiation.

Also considered are other angles of incidence. Figures (7), (8) and (9) show the power input and power transfer for different values of the incidence angles θ and ϕ . The angles of incidence considered have values of θ and ϕ given by 0° and 0° , 15° and 30° , and 75° and 60° respectively for figures (7), (8) and (9). The number of modes in figure (7) is reduced as compared to the other results mainly because of the symmetry of the excitation. The even modes are not excited with normal incidence. Apart from the number of modes that are excited the general shape of the power flow curves are also influenced by the angles of incidence.

CONCLUSION

The extension of the Power Flow Method to excitation conditions other than mechanical excitation has been demonstrated in this report. The excitation considered here is an incident acoustic wave. In this case of acoustic excitation, the response of the structure influences the incident acoustic field and the problem of the structure response becomes a fluid-structure interaction problem.

Since most of the work found in the literature on fluid-structure interaction deals with simply supported plate structures, because of the requirement of an a priori knowledge of the vibration mode shape, which is not valid in the case of connected plate structures, an approximate solution based on the work by Leppington [8] has been used here. Although fluid loading is considered, it is found that light fluid loading does not significantly modify the mode shape of the vibrating plate structure but that the scattered pressure can be significant.

If the results obtained here for the power input and transferred for the L-shaped plate acoustic excitation are compared to results for mechanical excitation [6], the following observation can be made. With uniformly distributed mechanical excitation, the power flow is similar to that for excitation from normal incidence acoustic waves. For oblique incidence waves additional modes of vibration are excited same as in the case of point excitation. Compared with the power flow results for point excitation, the power flow is higher in the case of the mechanical excitation. For these comparisons the total load on the source plate is kept constant.

As a final conclusion, an important result of this report is that the effects of fluid loading on a connected plate structure can be integrated into the general Power Flow Method. This enhances the usefulness of power flow methods in determining the response of plate-like structural components and their interaction with the surrounding medium.

REFERENCES

1. Cuschieri J.M., "Power Flow as a Complement to Statistical Energy Analysis and Finite Element Analysis", ASME, 1988.
2. Cuschieri J.M., "Extension of Vibrational Power Flow Techniques to Two-dimensional Structures", Contract Report Number 181710 NASA Langley Research Center, Hampton VA., 1988.
3. Pinnington R.J., White R.G., "Power Flow through Machine Isolators to Resonant and Non-resonant Beams", Journal of Sound and Vibration, 75(2), 179-197, 1981.
4. Gibert T.M., "Transmission of Vibrational Power in Joined Structures", Thesis, Master of Science in Engineering, Florida Atlantic University, 1988.
5. McCollum M.D., "Vibrational Power Flow in Thick Connected Plates", Ph D Dissertation, Florida Atlantic University, 1988.
6. Cuschieri J.M., "Application of the Mobility Power Flow Approach to Structural Response From Distributed Loading", Progress Report, Grant Number NAG-1-685, NASA Langley Research Center, Hampton VA., December, 1988.
7. Fahy F., "Sound and Structural Vibration", Academic Press, London, 1985.
8. Leppington F.G. "Scattering of Sound Waves by Finite Membranes and Plates near Resonances", Journal of Applied Mechanics, vol.XXXIX, Pt.4, 1976.

Appendix A

RELATIONSHIP BETWEEN SCATTERED PRESSURE AND NORMAL SURFACE VELOCITY

In deriving the relationship between pressure and normal surface velocity the following conditions are assumed (a) the plate normal displacement has a time dependency of the form

$$W(x,y,t) = W(x,y)\exp(j\omega t) \quad (\text{A.1})$$

(b) the plate is finite and lies in the plane $(x,y,0)$ with the fluid occupying the half-space $z \geq 0$; (c) the propagation of a plane acoustic wave in three dimensional space is given by:

$$p(x,y,z,t) = p\exp(-jk_x x -jk_y y -jk_z z)\exp(j\omega t) \quad (\text{A.2})$$

The Fourier transform of $W(y)$ is defined by:

$$W(\beta) = \int_{-\infty}^{+\infty} W(y)\exp(j\beta y)dy \quad (\text{A.3})$$

and the inverse transform by:

$$W(y) = \frac{1}{2\pi} \int_{-\infty}^{+\infty} W(\beta)\exp(-j\beta y)d\beta \quad (\text{A.4})$$

From the momentum equation in the z direction:

$$\frac{\partial p}{\partial z} + \rho_0 \frac{\partial V}{\partial t} = 0 \quad (\text{A.5})$$

where p is the acoustic pressure, ρ_0 the fluid mean density and V the particle velocity in the z direction. From equation (A.5)

$$-jk_z p_s(x, y, z) \exp(j\omega t) = -j\omega \rho_0 V(x, y, z) \exp(j\omega t) \quad (\text{A.6})$$

where p_s is the scattered pressure.

At the interface between the plate and the acoustic medium ($z = 0$), the surface normal velocity is equal to the acoustic particle velocity. Therefore at this interface

$$p_s(x, y) = \frac{\omega \rho_0}{k_z} V(x, y) \quad (\text{A.7})$$

where k_z must satisfy the condition:

$$k_x^2 + k_y^2 + k_z^2 = \left(\frac{\omega}{c}\right)^2 = k^2 \quad (\text{A.8})$$

where k is the acoustic wavenumber, ω the pulsation frequency and c the acoustic wave speed.

Let α and β be the plate wavenumbers in the X and Y directions respectively. Since the acoustic wave is generated by the plate motion, the X and Y variations of the acoustic field must follow those of the plate and

therefore:

$$k_x = \alpha \quad \text{and} \quad k_y = \beta \quad (\text{A.9})$$

$$\text{That is} \quad k_z^2 = k^2 - \alpha^2 - \beta^2 = k^2 - k_p^2 \quad (\text{A.10})$$

where k_p is the plate bending wavenumber

Spatial Fourier transforming equation (A.7) in the X and Y directions

$$p_s(\alpha, \beta) = \frac{\omega \rho_0}{k_z} V(\alpha, \beta) \quad (\text{A.11})$$

For a finite rectangular plate, simply supported at $x = 0$ and $x = a$, the response of the plate can be described by:

$$V(x, y) = \sum_{p=1}^{\infty} V(y) \sin\left(\frac{p\pi x}{a}\right) \quad (\text{A.12})$$

Fourier transforming the expression for $V(x, y)$

$$V(\alpha, \beta) = \sum_{p=1}^{\infty} V(\beta) \left(\frac{p\pi}{a}\right) \frac{(-1)^p \exp(+j\alpha a) - 1}{\alpha^2 - \left(\frac{p\pi}{a}\right)^2} \quad (\text{A.13})$$

For $p_s(x, y)$, this is first written in the form

$$p_s(x, y) = \sum_{m=1}^{\infty} p_s(y) \sin\left(\frac{m\pi x}{a}\right) \quad (\text{A.14})$$

where

$$p_s(y) = \frac{2}{a} \int_0^a p_s(x, y) \sin\left(\frac{m\pi x}{a}\right) dx$$

and then Fourier transforming in the Y direction

$$p_s(\beta) = \frac{2}{a} \int_0^a p_s(x, \beta) \sin\left(\frac{m\pi x}{a}\right) dx \quad (\text{A.15})$$

For the X direction, also taking a Fourier Transform

$$p_s(\beta) = \frac{2}{a} \int_0^a \left[\frac{1}{2\pi} \int_{-\infty}^{+\infty} p_s(\alpha, \beta) \exp(-j\alpha x) d\alpha \right] \sin\left(\frac{m\pi x}{a}\right) dx \quad (\text{A.16})$$

$$= \frac{1}{\pi a} \int_{-\infty}^{+\infty} p_s(\alpha, \beta) \left(\frac{m\pi}{a}\right) \frac{(-1)^m \exp(-j\alpha a) - 1}{\alpha^2 - \left(\frac{m\pi}{a}\right)^2} d\alpha \quad (\text{A.17})$$

Combining equations (A.11), (A.13) and (A.17) yields:

$$p_s(\beta) = \frac{\omega \rho_0}{\pi a} \left(\frac{m\pi}{a}\right) \sum_{p=1}^{\infty} \left\{ \left(\frac{p\pi}{a}\right) v(\beta) * \int_{-\infty}^{+\infty} \frac{(-1)^m \exp(j\alpha a) - 1}{\alpha^2 - \left(\frac{m\pi}{a}\right)^2} \frac{(-1)^p \exp(-j\alpha a) - 1}{\alpha^2 - \left(\frac{p\pi}{a}\right)^2} \frac{1}{k_z} d\alpha \right\} \quad (\text{A.18})$$

The terms of the summation for which $p \neq m$ represent intramodal coupling which has been shown to be negligible for light fluid loading provided the modal density of the structure is low.

Therefore equation (A.18) can be simplified to

$$p_s(\beta) = \frac{\omega \rho_0}{\pi a} \left(\frac{m\pi}{a}\right)^2 I(\beta) V(\beta) \quad (\text{A.19})$$

where

$$I(\beta) = 2 \int_{-\infty}^{+\infty} \frac{[1 - (-1)^m \cos \alpha a]}{[\alpha^2 - (\frac{m\pi}{a})^2]^2} \frac{1}{k_z} d\alpha \quad (\text{A.20})$$

From (A.20) equation (21) can be derived since the definition of the inverse Fourier transform is:

$$p_s(\xi) = \frac{1}{2\pi} \int_{-\infty}^{+\infty} p_s(\beta) \exp(-j\beta\xi) d\beta \quad (\text{A.21})$$

and substituting for $p_s(\beta)$

$$\int_0^b p_s(\xi) \sin(k_2 \xi) d\xi =$$

$$\frac{1}{2\pi} \frac{\omega \rho_0}{\pi a} \left(\frac{m\pi}{a}\right)^2 \int_{-\infty}^{+\infty} I(\beta) V(\beta) \left[\int_0^b \sin(k_2 \xi) \exp(-j\beta\xi) d\xi \right] d\beta$$

(A.22)

or, since $V(\beta) = j\omega W(\beta)$, where W is the displacement

$$\frac{1}{D_p} \int_0^b p_s(\xi) \sin(k_2 \xi) d\xi =$$

$$\frac{j}{2\pi^2 a} \left(\frac{m\pi}{a}\right)^2 \left(\frac{\omega^2 \rho_0}{D_p}\right) \int_{-\infty}^{+\infty} I(\beta) W(\beta) S(\beta) d\beta \quad (\text{A.23})$$

where

$$S(\beta) = \int_0^b \sin(k_2 \xi) \exp(-j\beta \xi) d\xi$$

$$= \frac{1}{\beta^2 - k_2^2} \left\{ -k_2 + \exp(-j\beta b) [j\beta \sin(k_2 b) + k_2 \cos(k_2 b)] \right\}$$

(A.24)

It should be noted that $S(\beta)$ is not the Fourier transform of $\sin(k_2 \xi)$. From this expression the scattered pressure component can be evaluated.

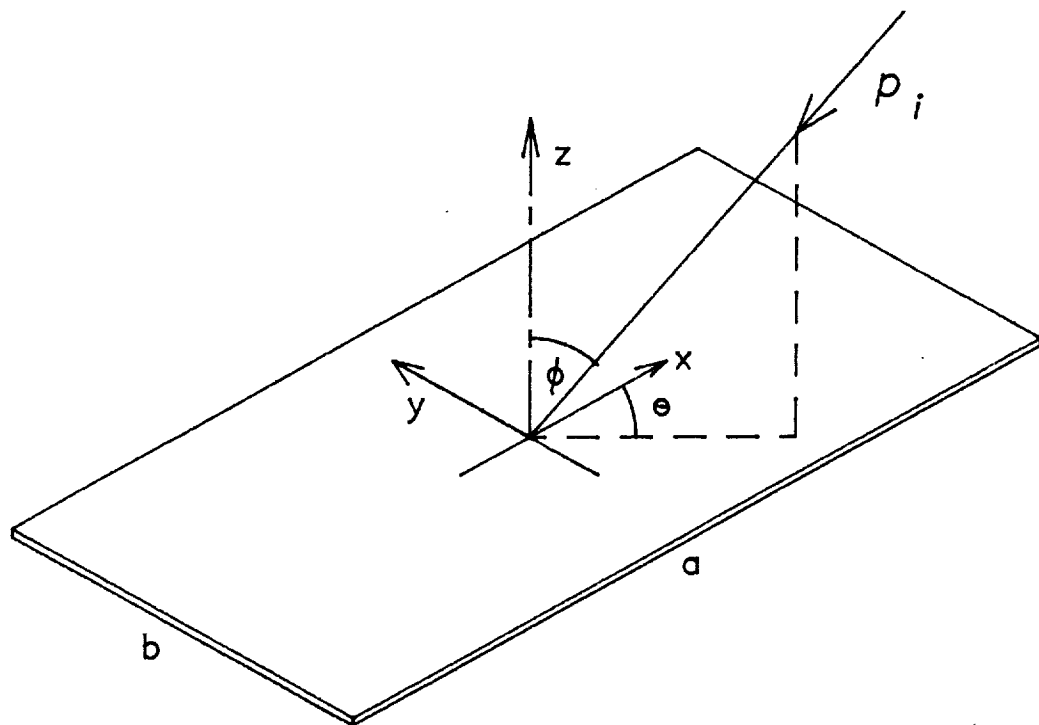
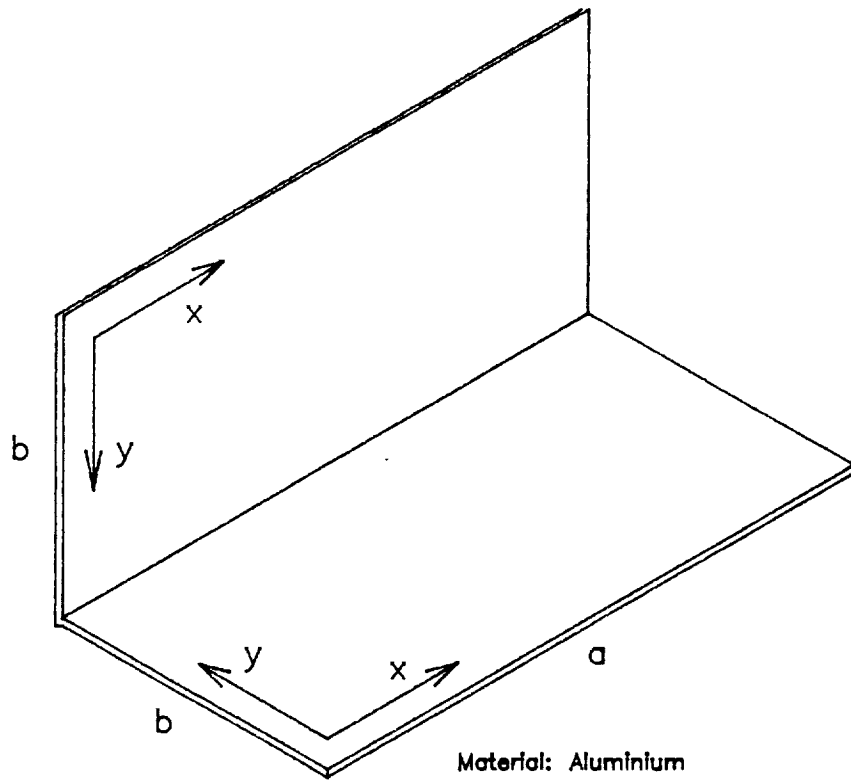

Figure 1. Incident acoustic pressure at oblique angle ϕ and θ .



Material: Aluminium
Density: 2710 Kg/m³
Elastic Modulus: 7.2 x10¹⁰ N/m²
Thickness: 0.00635m
Dimensions: a=1.0m, b=0.5m
Loss Factor: 0.01

Figure 2. Plate structure showing plate characteristics and coordinate directions.

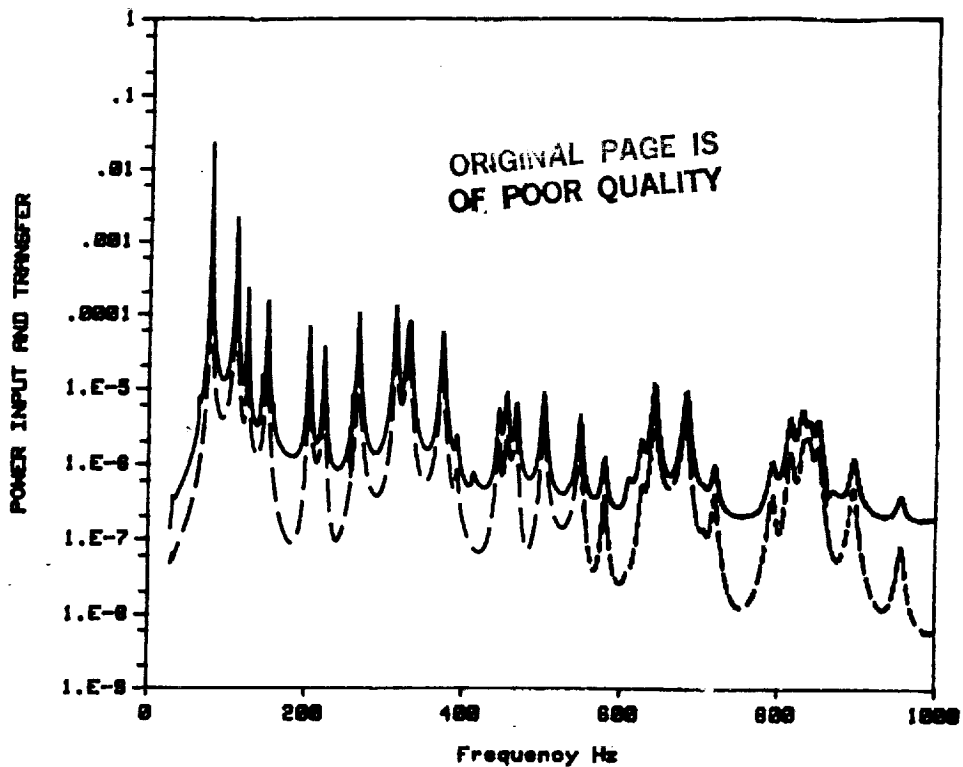

Figure 3. Power input and transfer per unit acoustic pressure with the influence of fluid loading for angle of incidence ϕ and θ equal 45° and 45° respectively. —: Power input; - -: power transfer.

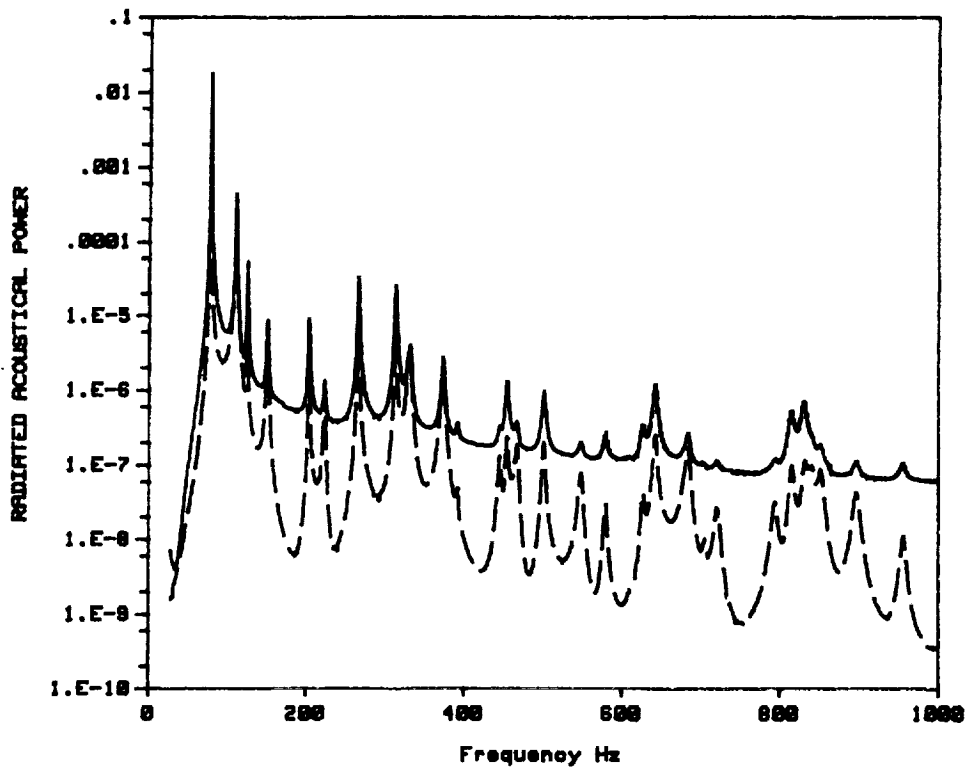

Figure 4. Radiated acoustical power per unit acoustic pressure by the source plate. —: Total radiated power; - -: contribution to radiated power from edge moment.

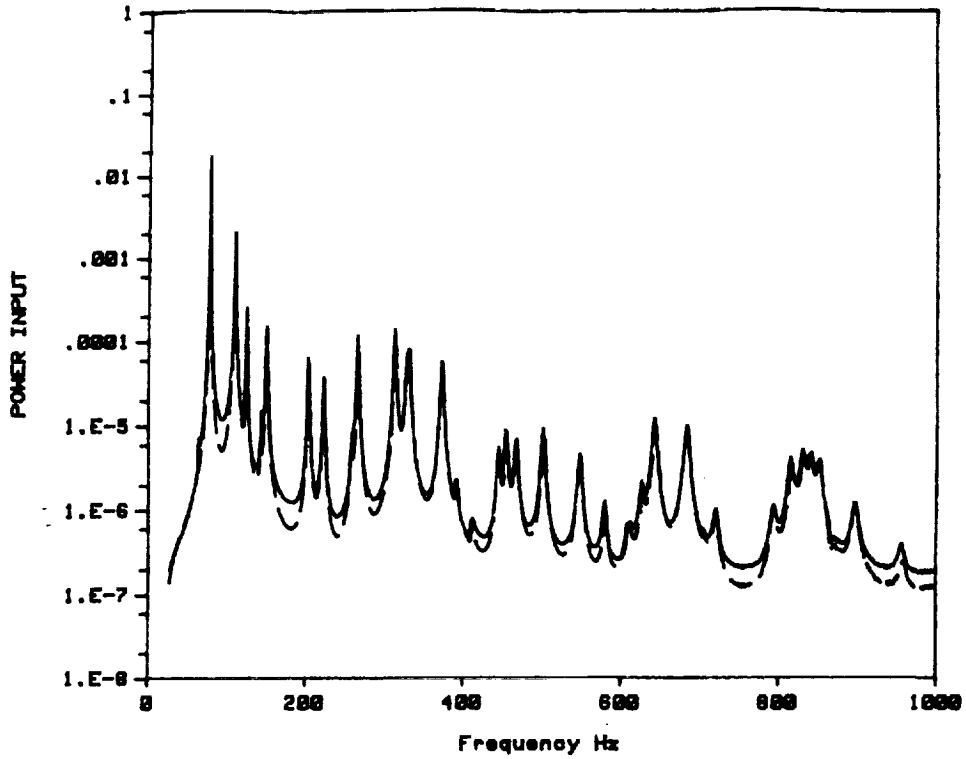

Figure 5. Power input per unit acoustic pressure with and without the influence of fluid loading. **—**: With Fluid loading effects; **- - -**: without fluid loading effects.

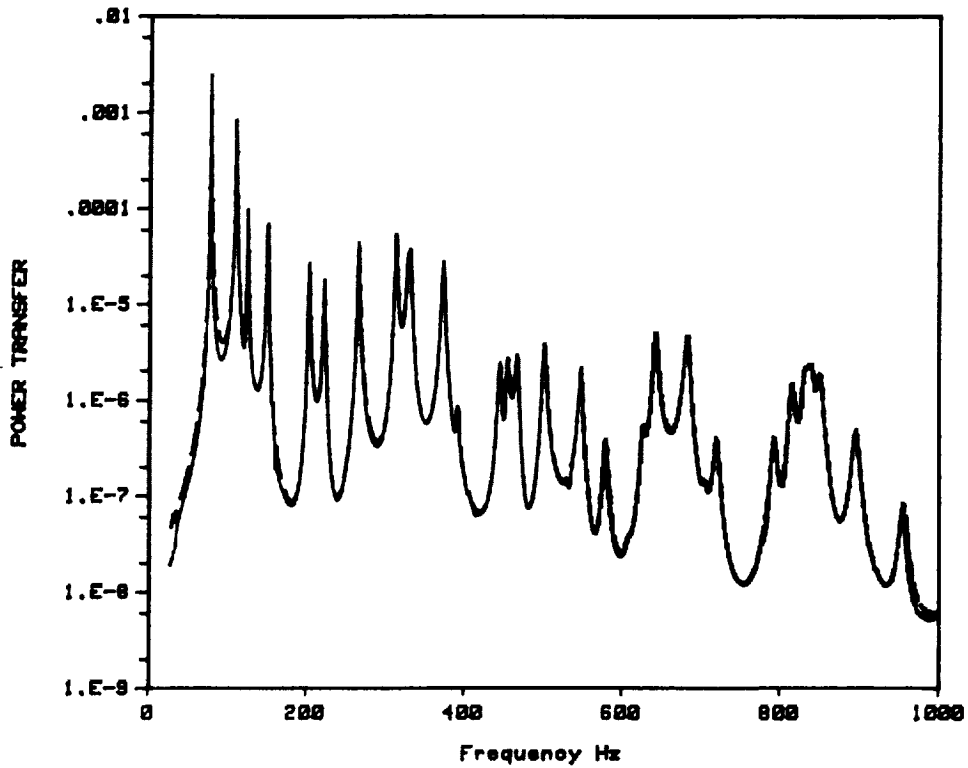

Figure 6. Power transfer per unit acoustic pressure with and without the influence of fluid loading. **—**: With Fluid loading; **- - -**: without fluid loading.

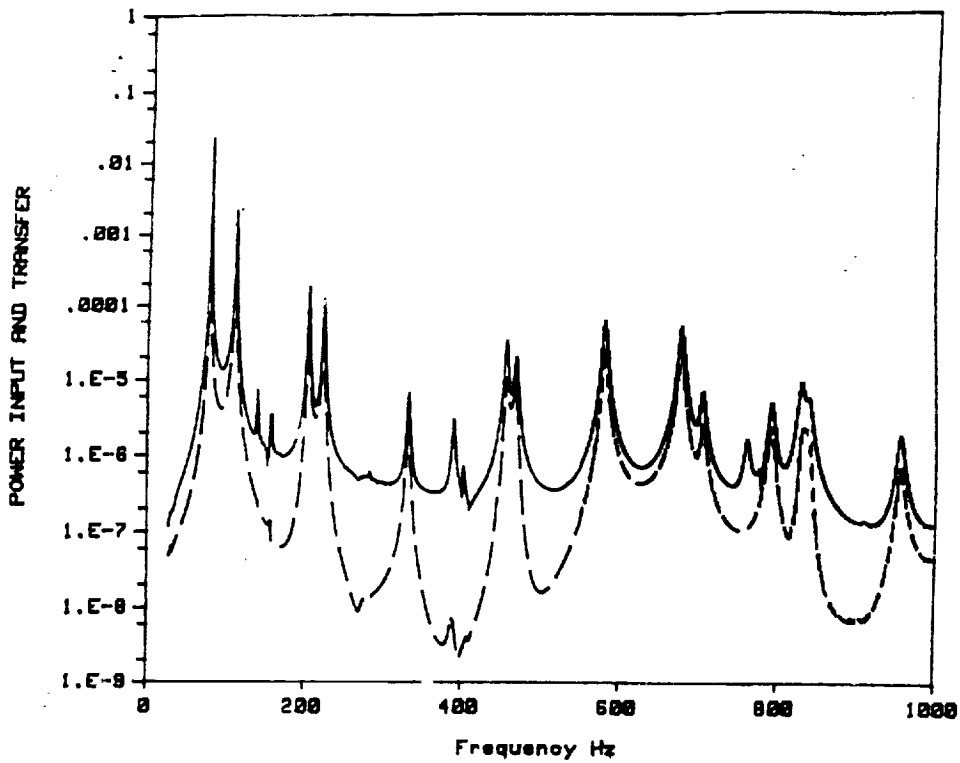

Figure 7. Power input and transfer per unit acoustic pressure with the influence of fluid loading for angle of incidence ϕ and θ equal 0° and 90° respectively. —: Power input; ---: power transfer.

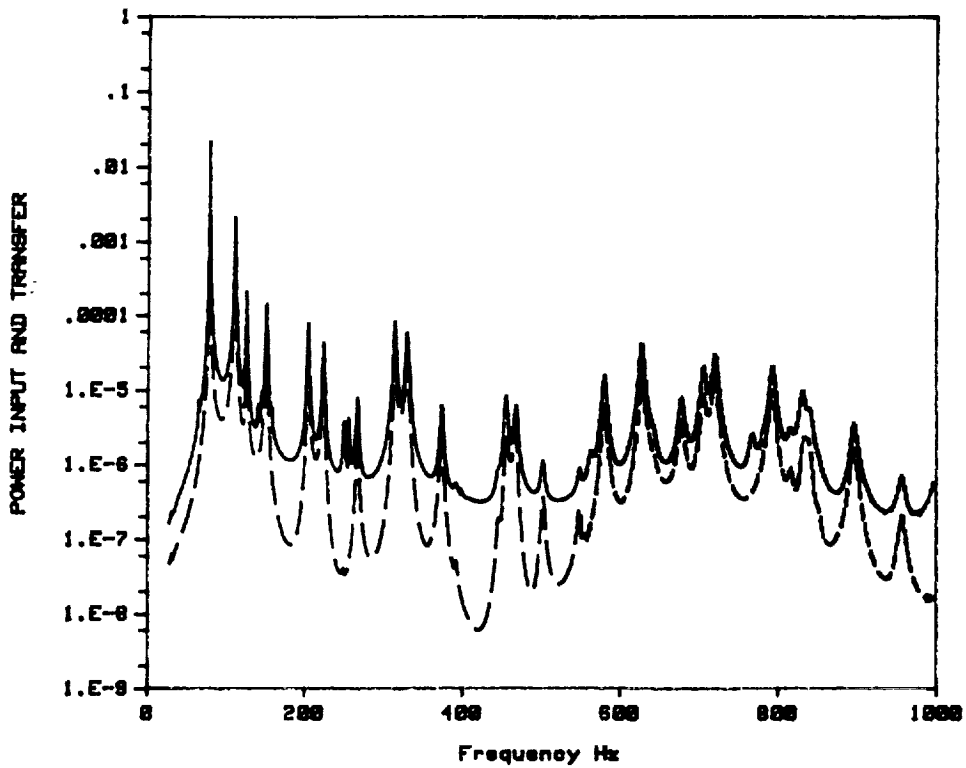

Figure 8. Power input and transfer per unit acoustic pressure with the influence of fluid loading for angle of incidence ϕ and θ equal 15° and 30° respectively. —: Power input; ---: power transfer.

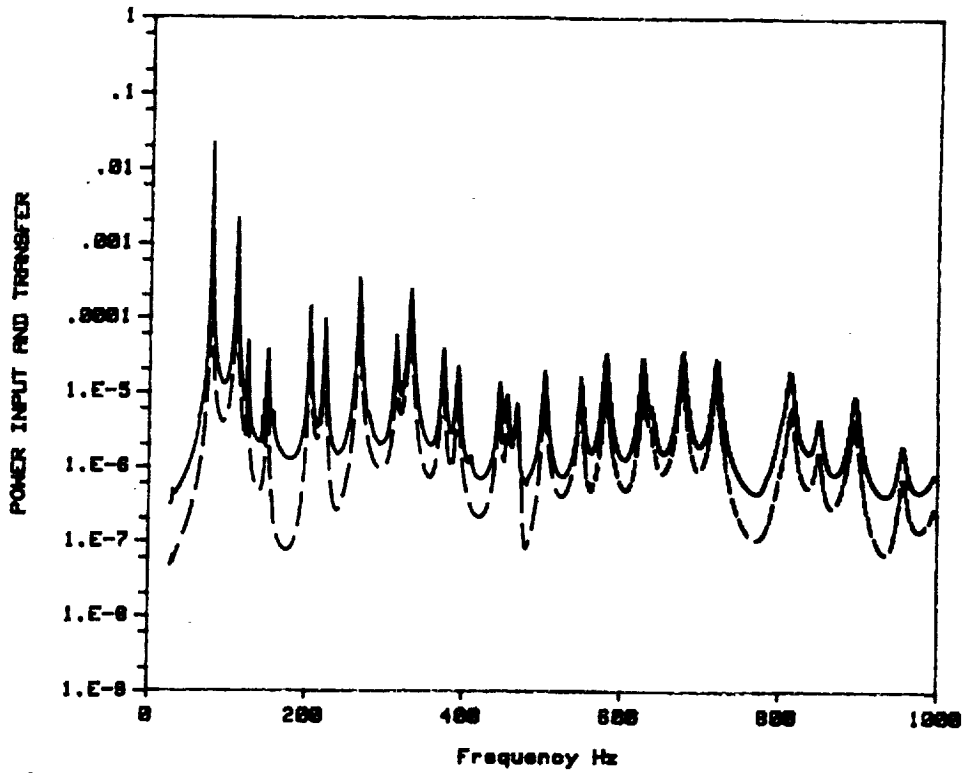

Figure 9. Power input and transfer per unit acoustic pressure with the influence of fluid loading for angle of incidence ϕ and θ equal 75° and 60° respectively. : Power input; ---: power transfer.