

552472  
20pgs

NASA Technical Memorandum 102393

# Calibration Approach to Electron Probe Microanalysis: A Study With PWA-1480, a Nickel Base Superalloy

F.M. Terepka  
*Lewis Research Center  
Cleveland, Ohio*

M. Vijayakumar and S.N. Tewari  
*Cleveland State University  
Cleveland, Ohio*

December 1989



(NASA-TM-102393) CALIBRATION APPROACH TO  
ELECTRON PROBE MICROANALYSIS: A STUDY WITH  
PWA-1480, A NICKEL BASE SUPERALLOY (NASA)  
18 p CSCL 11F

N90-14335

Unclas  
0252507

G3/26

**CALIBRATION APPROACH TO ELECTRON PROBE  
MICROANALYSIS:  
A STUDY WITH PWA-1480, A NICKEL BASE SUPERALLOY**

F.M. Terepka  
National Aeronautics and Space Administration  
Lewis Research Center  
Cleveland, Ohio 44135

M. Vijayakumar\* and S.N. Tewari  
Chemical Engineering Department  
Cleveland State University  
Cleveland, Ohio 44115

**ABSTRACT**

The utility of an indirect calibration approach in electron probe microanalysis is explored. The methodology developed is based on establishing a functional relationship between the uncorrected k-ratios and the corresponding concentrations obtained using one of the ZAF correction schemes, for all the desired elements in the concentration range of interest. In cases where a very large number of analyses are desired, such a technique significantly reduces the total time required for the microprobe analysis without any significant loss of precision in the data. A typical application of the method in the concentration mapping of the transverse cross-section of a dendrite in directionally solidified PWA-1480, a nickel-based superalloy, is described.

**INTRODUCTION**

The past three decades have seen the evolution of electron probe microanalysis from a specialized laboratory tool to a powerful and pervasive technique for the chemical identification and analysis of micron scale regions in a variety of materials including metals and alloys, ceramics, and geological specimens. Simple principles of x-ray generation and detection, founded in the early part of this century, form the basis of this method. In practice, the material under study is bombarded with a beam of electrons, energetic enough to lead to the emission of characteristic x-rays from all the constituent elements. The x-rays are then sorted according to their wavelengths using crystal diffractometers, and their intensity determined using x-ray counters. The wavelengths identify the atoms of the elements emitting them (Moseley's Law), and the intensities are a measure of the concentration of such atoms. Thus both chemical identification and analysis are achieved.

However, the correlation of the measured x-ray intensities to the concentration of the elements present is not a straight-forward process because of the non-linear nature of the interaction of electrons and x-rays with atoms comprising the material. For instance,

---

\*NASA Resident Research Associate, on leave from Defense Metallurgical Research Laboratory, Kanchanbagh, Hyderabad-500258, India.

as the electrons penetrate the material, they are scattered by the atoms and spread. In addition, their energy and hence their ability to generate x-rays, continually decreases. The extent of this decrease depends on the composition of the material and the total distance the electron has travelled. This leads to the generation of different amounts of x-rays at different depths. Also, as these x-rays travel out towards the detector, they are absorbed to different extents by the atoms in their path. Further, such an absorption can lead to the generation of secondary x-rays by the atoms involved. Each one of these factors, altering the total detected x-ray intensity, is dictated by the atomic number and composition of the material itself in a complex manner.

A sound understanding of the physics of interaction of electrons and x-rays with matter has led to the development of excellent theoretical models (refs. 1,2) to quantitatively correct the detected intensities of the characteristic x-rays, and extract the concentrations of the various elements. The calculations involved, however, are inherently tedious and time-consuming to perform. The advent of small, fast computers has given a fillip to automate a major part of the instrument operations involved in microprobe analysis and incorporate these correction schemes ON LINE so as to achieve almost instantaneous output of the analysis result. The correction methods used are popularly known as ZAF, Z for atomic number, A for absorption, and F for fluorescence corrections.

The use of on-line ZAF schemes necessitates the acquisition of x-ray intensity data on both the peak and the background of the x-ray lines for all the elements present in the material. This operation is very efficient when a few analyses on a variety of materials are desired. For carrying out analysis of a large number of points in the same specimen, however, a great deal of instrument time is lost in moving the crystal spectrometers back and forth to collect peak and background intensities, and in computing the corrections to the intensities. The objective of the present study is to investigate the possibility of using simple calibration schemes, akin to the ones used in other instrumental techniques of analysis, so as to reduce the instrument overheads with minimal restraints on various aspects of the analysis. The work reported here concerns the microprobe analysis of directionally solidified PWA-1480 nickel-base superalloy.

## **EXPERIMENTAL**

The sample under investigation was metallographically polished and etched lightly to reveal the microstructure. A 300 Å - 500 Å thin film of carbon was then coated on the surface, and the sample analysed using an Applied Research Laboratory model SEMQ electron probe microanalyser. After setting the operating conditions by selecting the beam voltage and current, x-ray count data for the peak and backgrounds of the elements Al, Ti, Cr, Ni, Co, W and Ta were collected by positioning the finely focussed electron beam on the corresponding pure element standards. Similar data were acquired

on the superalloy sample also. Such data-sets were built up over a period of time on different samples of the superalloy, so as to incorporate the indeterminate errors arising out of slight variations in the sample preparation steps and in the operating conditions of the microprobe. Based on these data, a calibration methodology was worked out and used in subsequent extensive analyses.

The ratios of the x-ray peak intensities on the superalloy sample for all the elements with respect to the corresponding intensities on the pure elemental standards, referred to as 'k-ratios', were calculated from the x-ray intensity data described above. In doing this, the peak intensities were corrected for the general x-ray background by subtracting the corresponding background intensities. The corrected 'k-ratios' thus obtained were processed through the ZAF correction schemes to get the concentration values. The 'k-ratios' corresponding to these concentrations, but not corrected for the background, referred to as 'raw k-ratios', were also calculated.

The software supplied by the manufacturer was suitably modified to output the raw k-ratios on to the printer port. This output was captured and stored on a floppy disk by connecting an IBM PC compatible at the printer port of the PDP-11 computer system of the electron microprobe. Data capture was accomplished using PROCOMM communication software at the PC end. The data on the floppy disk was subsequently transferred to an AMDAHL mainframe computer and converted to concentrations using the slopes and intercepts from the calibration data. The (x,y) position co-ordinates recorded from the microprobe were used to make the concentration maps for five elements, viz. Al, Ti, Co, W and Ta. The FORTRAN program used for this purpose is presented in appendix-I.

## **RESULTS AND DISCUSSIONS**

Figures 1(a)-(e) show the plot of 'raw k-ratios' for Al, Ti, Co, W and Ta vs. the corresponding ZAF corrected concentrations. A large number of data points (199 data) acquired over a period of one month in different sessions of operation of the microprobe, are represented in these graphs. The plots clearly show an excellent linear dependence of the corrected concentrations on the 'raw k-ratios' for all the elements. Two elements, nickel and chromium, were not included in these calculations as their analysis was not required for subsequent use, though they were analysed during the ZAF corrected analysis. Statistics of linear least squares analysis of the data is presented in Table-1. It is seen that linear relationship between the concentration and the 'raw k-ratios' was observed for all the elements, within a relative standard deviation (RSD) of less than 3 per cent in the concentration range of interest in the present study. This compares very well with 2 - 5 per cent RSD generally expected from microprobe analysis (refs. 1,2).

Thus, it is clear that a simple calibration scheme can be used in lieu of a complete

acquisition and ZAF correction method in the present case. Normally, one thinks of a calibration method only when standards with compositions bracketing the desired concentration range are available. Such standards must have known composition and a high degree of compositional homogeneity for their usefulness in microprobe analysis. Because of the high spatial resolution of the microprobe (of the order of a micrometer), their preparation in the case of multicomponent alloys is very difficult. In view of this, only an indirect calibration methodology can be adapted. Because of the availability of ON LINE computerized corrections schemes, such methods are rarely resorted to in practice. The present study shows that indirect calibration methods based on ZAF schemes themselves give satisfactory results. Once the calibration is established, the need for obtaining the background x-ray count rates and calculating the ZAF corrections for each and every point analysed vanishes. This results in significant savings in instrument time. In addition, unlike in the case of ZAF schemes where all the elements must be analysed for each data point, only the elements whose concentrations are desired need be analysed. In favourable cases, this can lead to further reduction in the analysis time. In the analysis of PWA-1480 superalloy samples, savings of over 75 per cent in time was achieved without any significant loss of precision in the analysis.

A typical application, where the full advantage of this methodology becomes obvious, is in the concentration mapping of large regions covering the microstructure of interest. Fig.2 shows a transverse cross-section of a PWA-1480 single crystal sample directionally solidified at a growth rate of  $10 \mu\text{m/s}$ . The microstructure consists of uniformly distributed primary dendrites with four side branches (lobes). Concentration information across the dendrites in this sample will be very useful in understanding the microsegregation occurring during directional solidification. If we wish to cover one quadrant of the flower-petal pattern of a primary dendrite in the microstructure, (shown in fig. 3(a), i.e. an area of  $250 \mu\text{m} \times 250 \mu\text{m}$ , a total of over 400 points have to be analysed if we choose an interval of  $4 \mu\text{m}$  on one axis and  $50 \mu\text{m}$  on the other. It takes 125 seconds to analyse a point, and hence a total of over 14 hours of instrument time will be required to carry out a complete ZAF corrected analyses. Adoption of the calibration scheme outlined above to obtain the concentrations has reduced this instrument usage time to about 3 hours.

Iso-concentration contours indicating the variation of concentration of tantalum across the dendrite arm are shown in fig.3(b). Distributions of other elements, Al, Ti, Co and W in the same region are shown in figs.4(a)-(d). The shape of the iso-concentration contours in fig. 3(b) shows that the side branches have grown in a symmetrical manner. These figures can therefore be used to obtain the solute concentration as a function of fraction solid in the mushy zone. It is also interesting to note that Ta, Ti and Al show a solute poor dendrite core, and a solute-rich interdendritic region. Elements Co and W, on the other hand, show an exactly opposite behaviour. These plots can therefore be used to

obtain solute partition coefficients for elements in a complex commercial superalloy. This partitioning behaviour in PWA-1480 is similar to the corresponding nickel-based binaries.

### **SUMMARY AND CONCLUSIONS**

The results presented here show the possibility of using an indirect calibration scheme in doing electron probe microanalysis, in lieu of a complete ZAF corrected analysis. This method, when suitable, can lead to a very significant decrease in the instrument time especially in the case multicomponent alloys, by (a) obviating the need for the acquisition of background x-ray count data for all the points analysed, and (b) restricting the analysis only to the elements for which concentration data is sought. In the case of microanalysis of PWA-1480, this approach resulted in the reduction of instrument usage time of over 75 per cent compared to a complete ZAF corrected analysis, without any significant loss in the precision of the data. The possibility of using this approach can be easily assessed by carrying out a reasonably good number of complete ZAF corrected analyses, and testing the correlation of the 'raw k-ratios' with the ZAF corrected concentrations. The method however is not advantageous when only a few analyses are desired.

### **ACKNOWLEDGEMENTS**

This research was supported in part by a grant, NAG-8-091, from NASA Marshall Space Flight Center. Experimental support from Microgravity Materials Science Laboratory, especially Chris Johnston and Karen Crandell, at NASA Lewis Research Center is appreciated. James E. Lee of Marshall Space Flight Center provided the PWA-1480 samples.

### **REFERENCES**

1. J. I. Goldstein, D. E. Newbury, P. Echlin, D. C. Joy, C. Fiori, E. Lifshin, Scanning Electron Microscopy and X-ray Microanalysis, Plenum Press, New York (1981).
2. J. I. Goldstein, H. Yakowitz, Practical Scanning Electron Microscopy, Plenum Press, New York (1975).

APPENDIX—I

PROGRAM MICMAP

```

C
C CONCENTRATION MAPPING OF MICROPROBE ANALYSIS DATA
C INPUT -----> X Y K-RATIO'S
C
  PARAMETER (NRANGE=9,NEL=5)
  REAL RANGE(NRANGE),C1(NEL),CINT(NEL),SLOPE(NEL)
  CHARACTER SYM(NEL)*2
  CHARACTER*1 CODE(NRANGE),GRID(46,76),XBRDR,YBRDR
C
  DATA SYM/ 'AL' , 'TI' , 'CO' , 'W' , 'TA' /
  DATA SLOPE/1.731938,1.031888,1.095528,1.629183,1.456113/
  DATA CINT/-0.18650,-0.16070,-1.13400,-0.49120,0.539100/
  DATA GRID/3496*' '/, XBRDR/'-'/, YBRDR/'.'/
  NELNO = 5
C1 DATA RANGE/4.0,4.4,4.8,5.2, 5.6, 6.0, 6.5, 7.0, 9.0/
C2 DATA RANGE/0.0,0.7,0.9,1.1, 1.3, 1.5, 2.0, 2.5, 3.5/
C3 DATA RANGE/2.0,3.0,4.0,4.5, 5.0, 5.5, 6.0, 6.5, 9.9/
C4 DATA RANGE/2.0,3.0,3.5,4.0, 4.5, 5.1, 5.8, 6.5, 9.9/
  DATA RANGE/6.0,7.0,8.0,9.0,10.0,11.0,12.0,13.0,20.0/
  DATA CODE/ '1','2','3','4', '5', '6', '7', '8', '0'/
  DATA XCHAR/75./
  CALL AMTMAX(XMIN,XMAX,YMIN,YMAX)
  XORG=XMIN
  YORG=YMAX
  XRANGE=ABS(XMAX-XMIN)
  Y1=ABS(YMAX-YMIN)
  IF(XRANGE.LT.Y1)XRANGE=Y1
  XFACT=XCHAR/XRANGE
  YFACT=0.6*XFACT
C
C WRITE(6,1101)
C1101 FORMAT(2X,'####WANT K-RATIO VS. CONC. PRINTOUT?(0/1)')
C
C READ(5,*)IPRT
C
  IPT=0
  READ(10,*,END=99)
  9 IPT=IPT+1
  READ(10,*,END=99)PT,X,Y,(C1(I),I=1,NEL)
  C=CINT(NELNO)+SLOPE(NELNO)*C1(NELNO)
  IF(IPRT.EQ.1)WRITE(6,*)PT,C1(NELNO),C
C
C GRID INDICES DEFINITIONS
C
  N=2+INT(ABS(X-XORG)*XFACT)
  M=2+INT(ABS(Y-YORG)*YFACT)
  GRID(M,N)='- '
  IF(C.GE.RANGE(NRANGE))GRID(M,N)='+'
  DO 25 I=1,NRANGE-1
  IF(C.GE.RANGE(I+1).OR.C.LT.RANGE(I))GO TO 25
  GRID(M,N)=CODE(I)
  25 CONTINUE
C
  WRITE(6,*)M,N,X,Y,GRID(M,N)
  GO TO 9
C
  99 CONTINUE
  DO 30 I=1,76
  GRID(1,I)=XBRDR
  GRID(46,I)=XBRDR
  30 CONTINUE
  DO 55 I=1,46

```

```

GRID(I,1)=YBRDR
GRID(I,76)=YBRDR
55 CONTINUE

```

C

```

WRITE(6,101)((GRID(I,J),J=1,76),I=1,46)
101 FORMAT(1X,76A1)
WRITE(20+NELNO,102)((GRID(I,J),J=1,76),I=1,46)
102 FORMAT(2X,76A1)
WRITE(20+NELNO,103)(RANGE(I),I=1,NRANGE)
WRITE(20+NELNO,104)SYM(NELNO),(I,I=1,NRANGE-1)
WRITE(20+NELNO,105)XRANGE
WRITE(6,103)(RANGE(I),I=1,NRANGE)
WRITE(6,104)SYM(NELNO),(I,I=1,NRANGE-1)
WRITE(6,105)XRANGE
103 FORMAT(12X,'RANGE(WT%) : ',9F8.1)
104 FORMAT(12X,' CODE( ',A2,' ) : ',9(5X,I1))
105 FORMAT(12X,'TOTAL X- OR Y- AXIS LENGTH -> ',F8.1,'-MICRONS')
STOP
END

```

```

SUBROUTINE AMIMAX(XMIN,XMAX,YMIN,YMAX)
READ(10,*)
IPT=0
READ(10,*,END=99)
9 IPT=IPT+1
READ(10,*,END=99)PT,X,Y,C,C,C,C,C
IF(IPT.GT.1)GO TO 10
XMIN=X
XMAX=X
YMIN=Y
YMAX=Y
10 IF(X.LT.XMIN)XMIN=X
IF(X.GE.XMAX)XMAX=X
IF(Y.LT.YMIN)YMIN=Y
IF(Y.GE.YMAX)YMAX=Y
GO TO 9
99 CONTINUE
REWIND(UNIT=10)
RETURN
END

```

```

/* Exec file for running on VM/AMDAHL -/
'FILEDEF 10 DISK GSCAN131 DAT'
'FILEDEF 21 DISK GSCAN131 AL'
'FILEDEF 22 DISK GSCAN131 TI'
'FILEDEF 23 DISK GSCAN131 CO'
'FILEDEF 24 DISK GSCAN131 W '
'FILEDEF 25 DISK GSCAN131 TA'
'LOAD MICMAP (CLEAR START'

```



TABLE 1.—CALIBRATION STATISTICS

	Slope	Intercept	C.V.	R <sup>2</sup>
Al	173.194	-0.186	2.272	0.969
Ti	103.189	-0.161	2.797	0.997
Co	109.553	-1.134	1.455	0.966
W	162.918	-0.491	2.696	0.991
Ta	145.611	0.539	2.857	0.993

C.V.: Coefficient of variation; R<sup>2</sup>: Correlation Coefficient

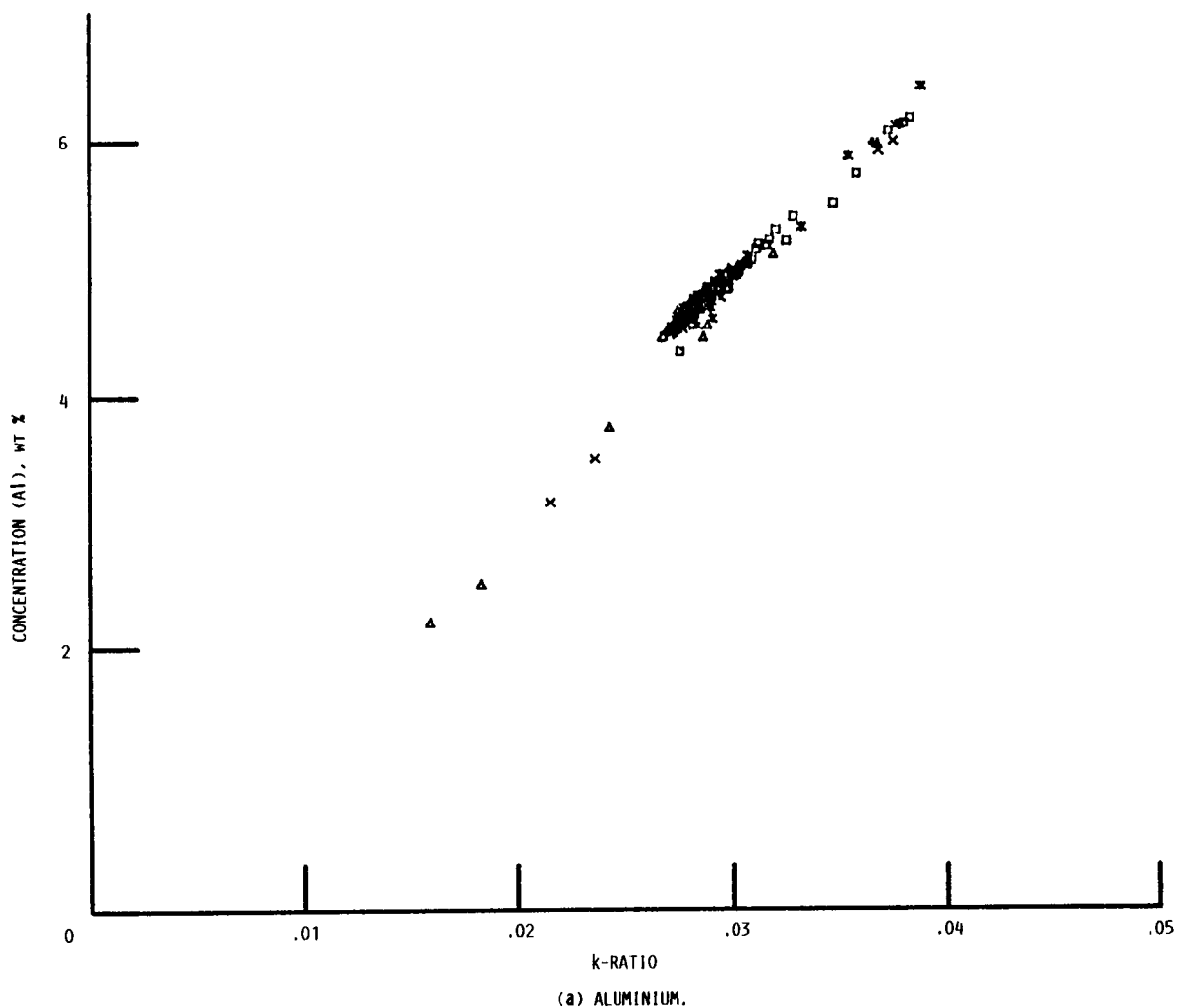
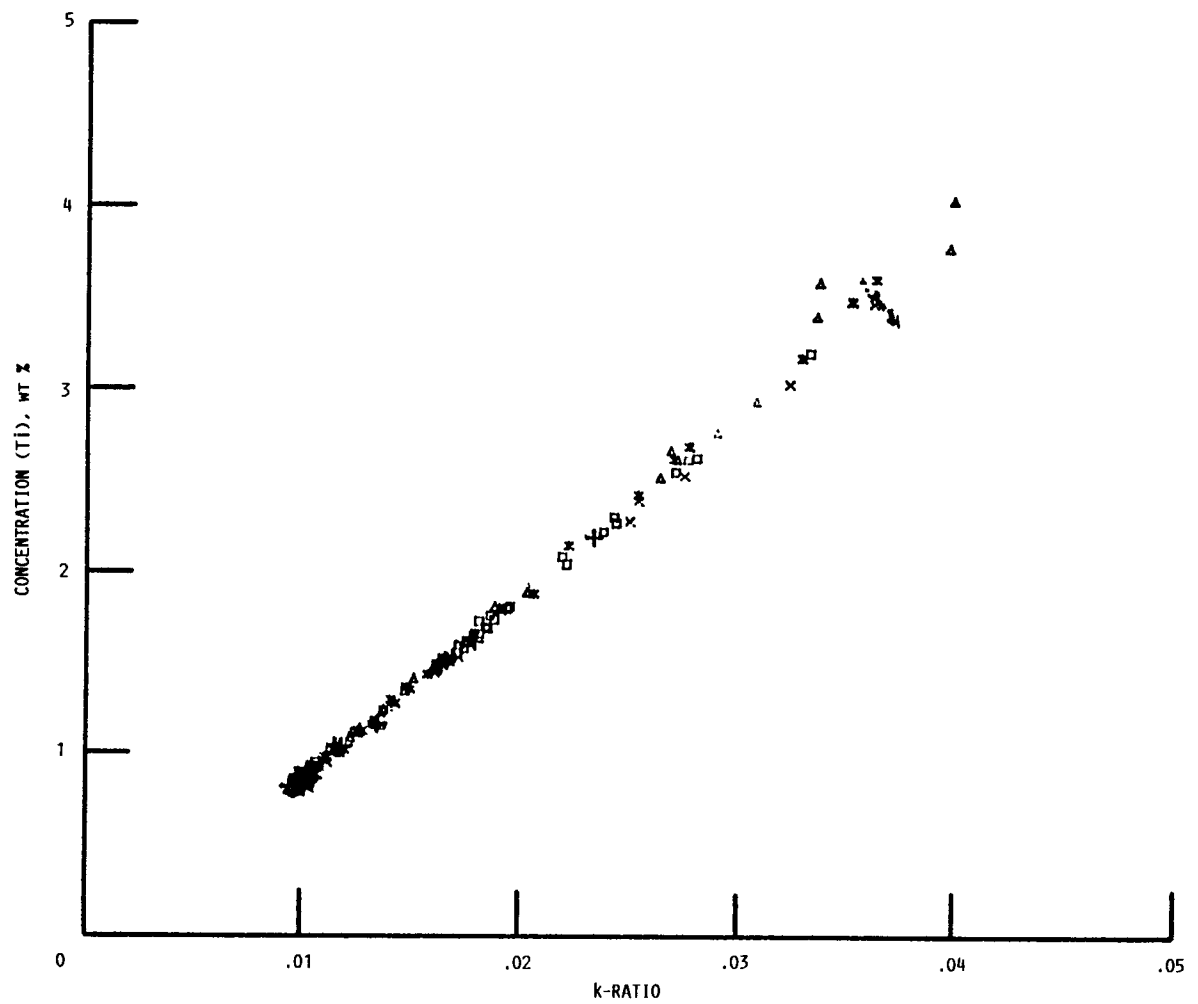

FIGURE 1. - CALIBRATION PLOT OF ZAF CORRECTED CONCENTRATION VERSUS RAW k-RATIO'S FOR VARIOUS ELEMENTS IN PWA-1480 NICKEL BASE SUPERALLOY.



(b) TITANIUM.  
 FIGURE 1. - CONTINUED.

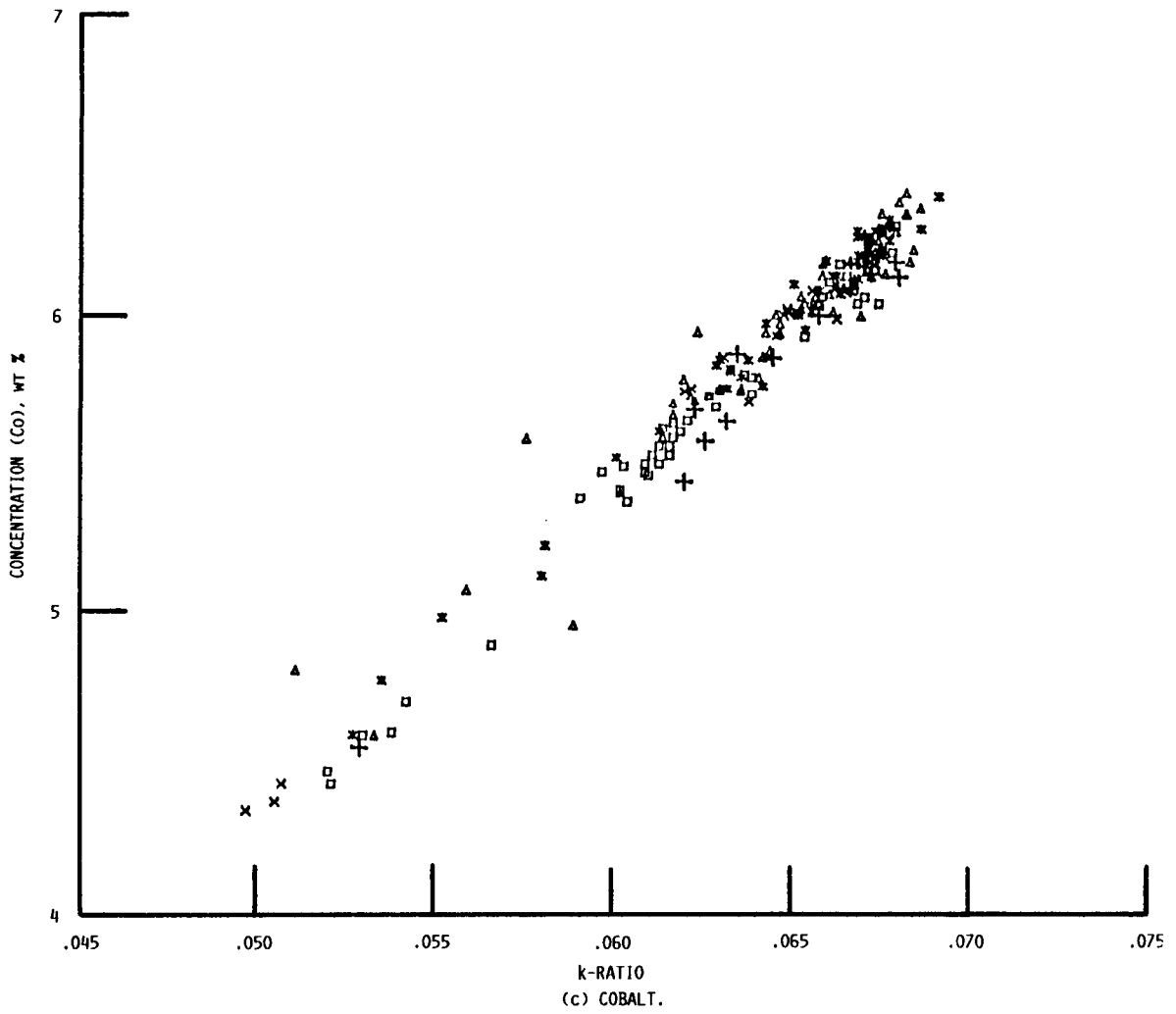
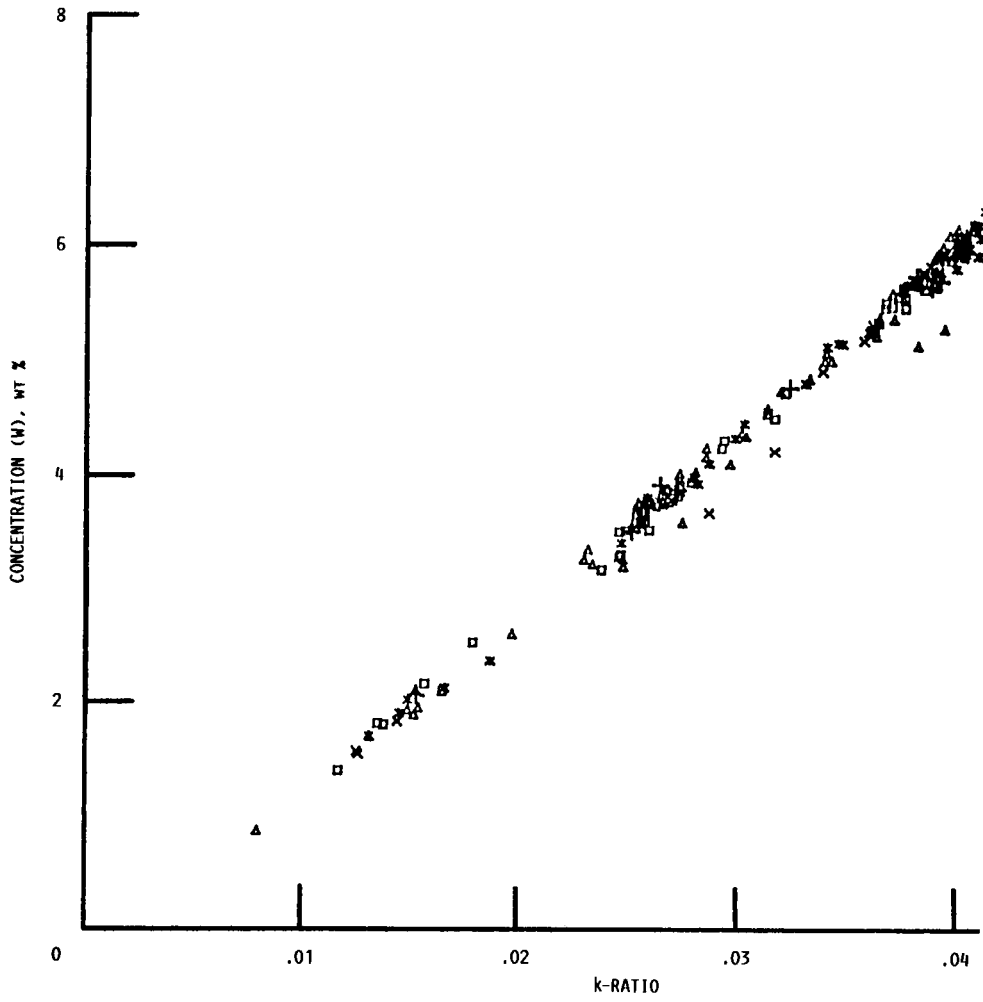
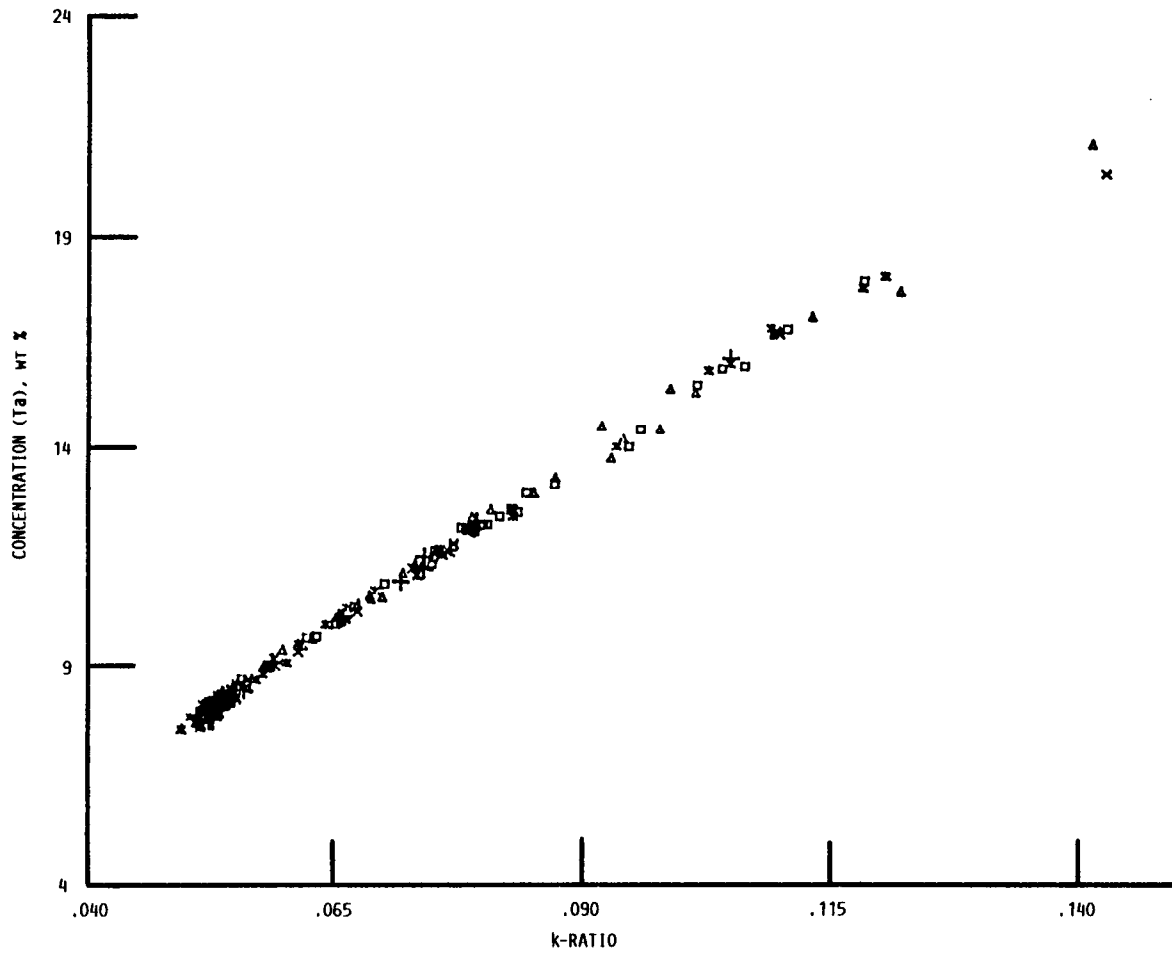

FIGURE 1. - CONTINUED.



(d) TUNGSTEN.

FIGURE 1. - CONTINUED.



(e) TANTALUM.  
 FIGURE 1. - CONCLUDED.

ORIGINAL PAGE  
BLACK AND WHITE PHOTOGRAPH

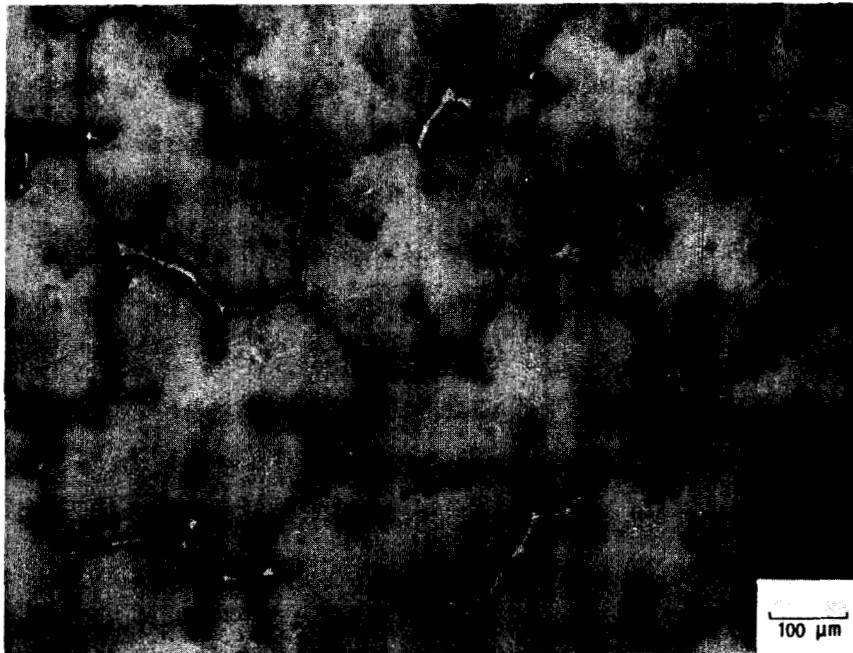
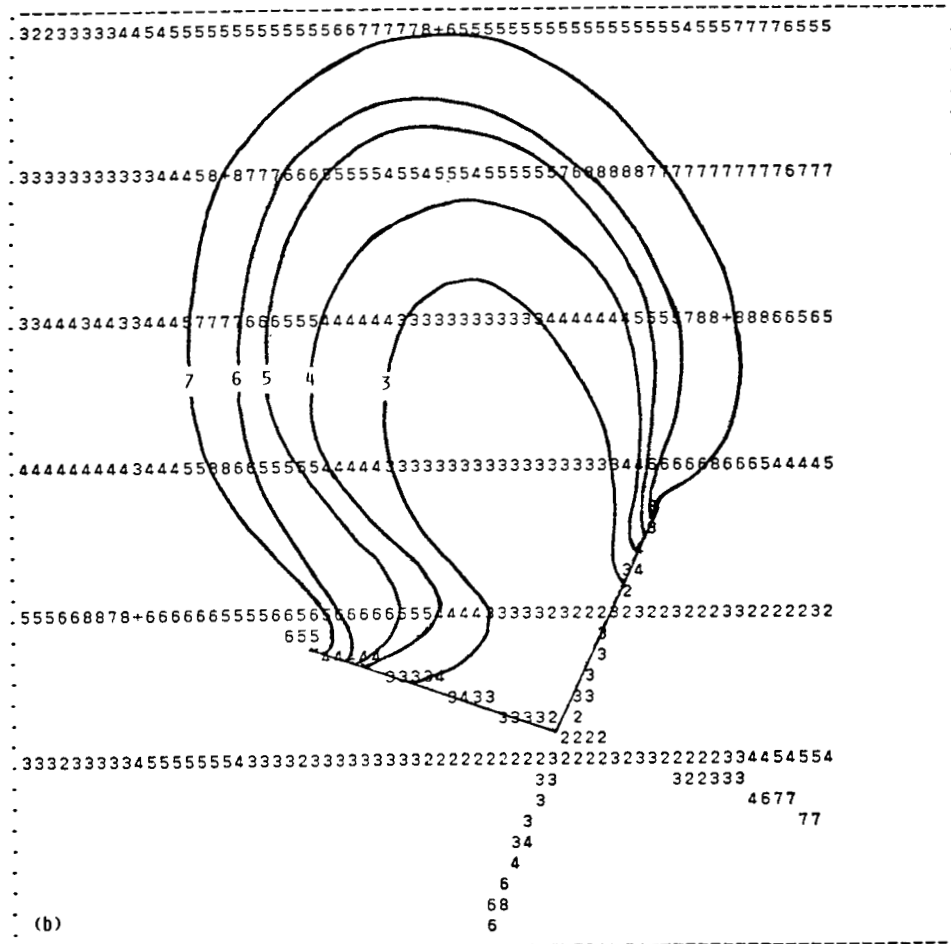
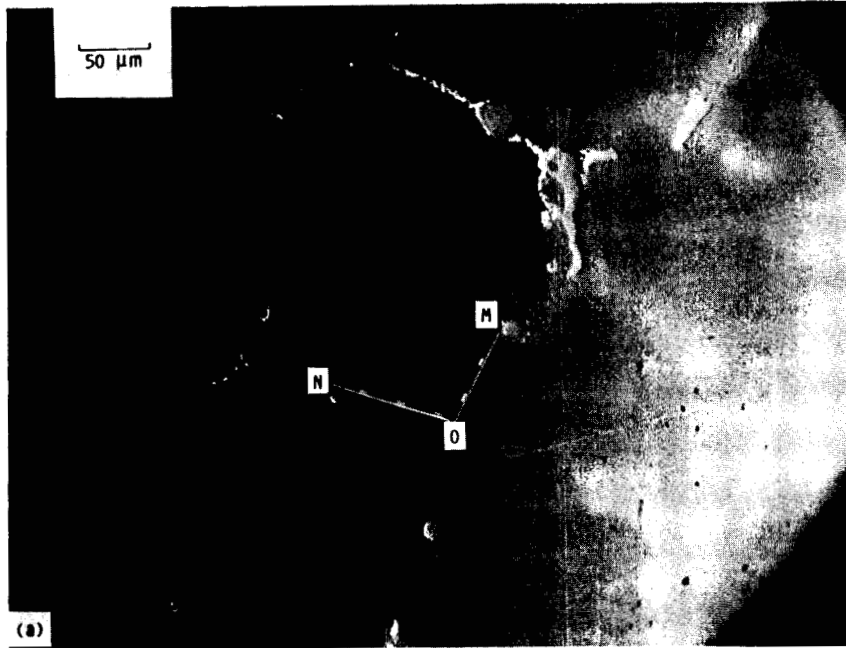

FIGURE 2. - TRANSVERSE CROSS-SECTION OF A DIRECTIONALLY SOLIDIFIED PWA-1480 SUPER-ALLOY SAMPLE SHOWING THE DENDRITES.



RANGE(WT%) : 6.0 7.0 8.0 9.0 10.0 11.0 12.0 13.0 20.0  
 CODE( TA) : 1 2 3 4 5 6 7 8  
 TOTAL X- OR Y- AXIS LENGTH -> 320.0-MICRONS

FIGURE 3. - CONCENTRATION MAPPING.

ORIGINAL PAGE  
 BLACK AND WHITE PHOTOGRAPH





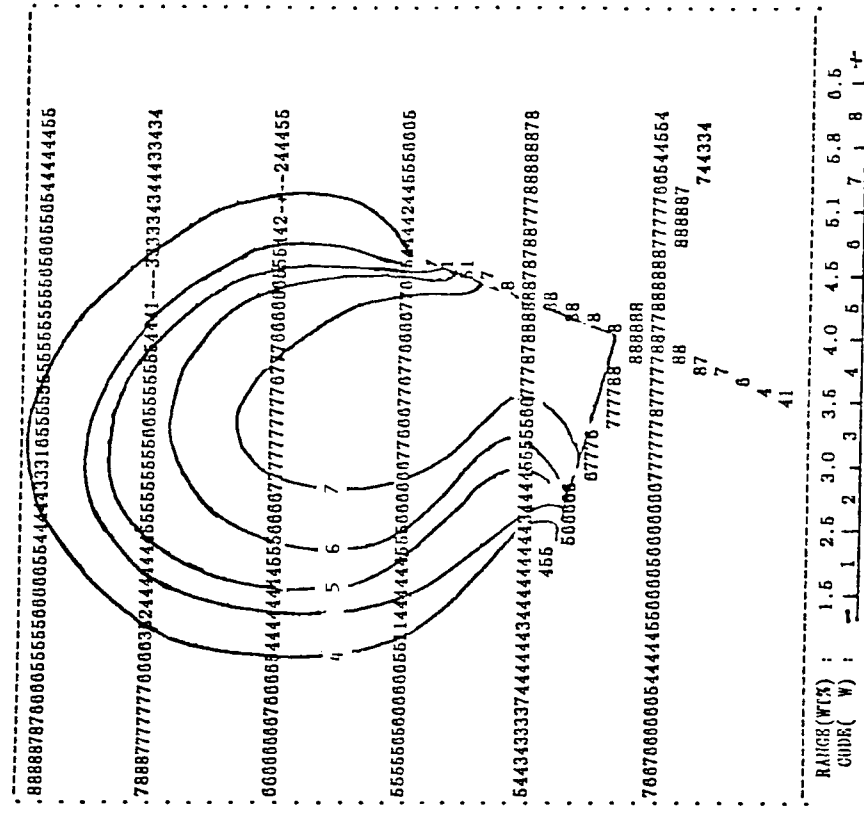
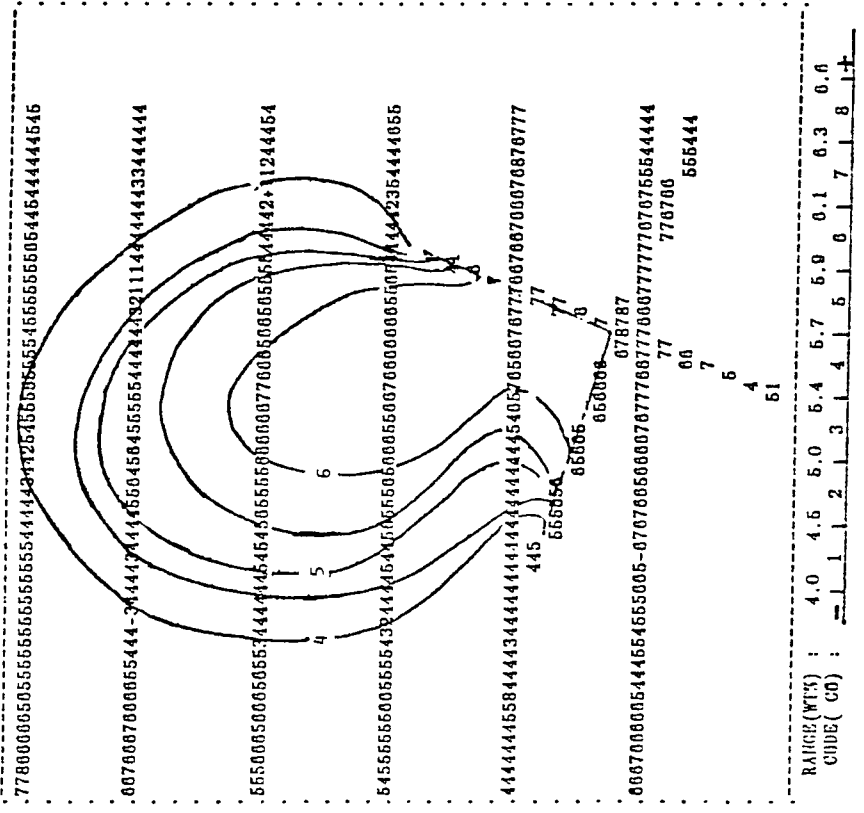

FIGURE 4. - CONCLUDED.



# Report Documentation Page

1. Report No. NASA TM-102393		2. Government Accession No.		3. Recipient's Catalog No.	
4. Title and Subtitle Calibration Approach to Electron Probe Microanalysis: A Study With PWA-1480, a Nickel Base Superalloy			5. Report Date December 1989		
			6. Performing Organization Code		
7. Author(s) F.M. Terepka, M. Vijayakumar, and S.N. Tewari			8. Performing Organization Report No. E-5138		
			10. Work Unit No. 505-63-1A		
9. Performing Organization Name and Address National Aeronautics and Space Administration Lewis Research Center Cleveland, Ohio 44135-3191			11. Contract or Grant No.		
			13. Type of Report and Period Covered Technical Memorandum		
12. Sponsoring Agency Name and Address National Aeronautics and Space Administration Washington, D.C. 20546-0001			14. Sponsoring Agency Code		
			15. Supplementary Notes F.M. Terepka, NASA Lewis Research Center: M. Vijayakumar, Chemical Engineering Department, Cleveland State University, Cleveland, Ohio 44115 and NASA Resident Research Associate; on leave from Defense Metallurgical Research Laboratory, Kanchanbagh, Hyderabad-500258, India. S.N. Tewari, Chemical Engineering Department, Cleveland State University.		
16. Abstract The utility of an indirect calibration approach in electron probe microanalysis is explored. The methodology developed is based on establishing a functional relationship between the uncorrected k-ratios and the corresponding concentrations obtained using one of the ZAF correction schemes, for all the desired elements in the concentration range of interest. In cases where a very large number of analyses are desired, such a technique significantly reduces the total time required for the microprobe analysis without any significant loss of precision in the data. A typical application of the method in the concentration mapping of the transverse cross-section of a dendrite in directionally solidified PWA-1480, a nickel-based superalloy, is described.					
17. Key Words (Suggested by Author(s)) Superalloy Microprobe Microsegregation Microanalysis			18. Distribution Statement Unclassified - Unlimited Subject Category 26		
19. Security Classif. (of this report) Unclassified		20. Security Classif. (of this page) Unclassified		21. No of pages 18	22. Price* A03