

Base Reaction Optimization of Redundant Manipulators for Space Applications

C.L. Chung, S. Desa, and C.W. deSilva

CMU-RI-TR-88-17

RECEIVED
FEB 2 0 1989
NASA

FEB 2 0 1989

LANGLEY RESEARCH CENTER
L-17
NASA
HAMPSHIRE, VIRGINIA

Department of Mechanical Engineering
The Robotics Institute
Carnegie Mellon University
Pittsburgh, Pennsylvania 15213

September 1988

© 1988 Carnegie Mellon University

This research has been supported by NASA Lewis Research Center through contract NAG3-811.

C.W. deSilva: Dept. of Mechanical Engineering, University of British Columbia, Vancouver, Canada.

Table of Contents

1	Introduction	1
2	Outline of Contents	2
3	Problem Statement	2
4	Description of the Approach	4
5	Part 1- Generation of End-effector Trajectory	5
6	Part 2- Joint Space Solution	7
	6.1 Redundancy Resolution	7
	6.2 Optimization Problem Formulation	9
	6.3 Cost Function	10
	6.4 Optimization Scheme	11
	6.5 Optimization Technique	12
7	Algorithm of the Approach	12
8	Illustrative Example	12
	8.1 End-effector Trajectory	15
	8.2 Cost Function	15
	8.21 Case 1	15
	8.22 Case 2	16
	8.23 Case 3	16
	8.3 Optimization Scheme	17
	8.4 Discussion of Results	17
9	Conclusions	21
	Appendix : Kinematics Analysis	22
	References	26

List of Figures

1	A m DOF Redundant Manipulator	3
2	Flowchart of the Algorithm of Trajectory Planning	13
3	A 4 DOF Spatial Redundant Traction-drive Manipulator	14
4	Optimized Magnitude of Base Force	18
5	Optimized Magnitude of Base Moment	18
6	Time History of End-effector Trajectory (x- component)	19
7	Time History of End-effector Trajectory (y -component)	19
8	Time History of End-effector Trajectory (z -component)	20
9	Optimal Joint Trajectory (q_1) of Case3	20

Abstract

One of the problems associated with redundant manipulators which have been proposed for space applications is that the reactions transmitted to the base of the manipulator as a result of the motion of the manipulator will cause undesirable effects on the dynamic behavior of the supporting space structure. It is therefore necessary to minimize the magnitudes of the forces and moments transmitted to the base. In this report we show that kinematic redundancy can be used to solve the dynamic problem of minimizing the magnitude of the base reactions. The methodology described in the report is applied to a four degree-of-freedom spatial manipulator with one redundant degree-of-freedom.

1.0 Introduction

In the near future, autonomous robotic manipulators will be used on space stations to perform exhaustive tasks such as repairing of the exterior of a space station [1], and performing delicate experiments, etc. The employment of these manipulators will reduce extravehicular activity of the astronauts and free them for other tasks.

Manipulators used in space are operated under microgravity conditions. Furthermore such manipulators will in general have redundant degrees of freedom in order to facilitate the performance of tasks. (It is well known that redundant manipulators can be used to avoid obstacles, avoid singular configurations, etc. [4]). In this research we are concerned with planning trajectories for redundant manipulators operating under microgravity conditions in space.

The forces and moments transmitted by such "space" manipulators to the supporting structure will, in general, act as a disturbance on the spacecraft and therefore have an undesirable effect on the dynamic behavior of the spacecraft. Compensating for the disturbance (caused by the transmitted forces and moments) by means of a suitable control scheme is extremely difficult and expensive. An alternative approach, described in this report, is to plan a trajectory which minimizes the magnitude of the forces and moments transmitted by the manipulator to the supporting structure. (We will refer to these forces and moments as the base reactions.)

The trajectory-planning problem for a manipulator reduces to the problem of solving the inverse-kinematic problem for the joint variables given the trajectory in the task-space. In the case of a non-redundant manipulator, this inverse-kinematic problem has, in general, a unique solution whereas in the redundant case, there are an infinite number of solutions to the inverse-kinematic problem. In this paper we pose an optimization problem of minimizing the base reactions in order to obtain a unique solution to the inverse-kinematic problem.

Since there is a large body of research -see, for example, [2,3,4,5,6] - it is important at the outset to indicate the contributions of the current work. In contrast to most of the research on redundant manipulators, which has focused on the kinematics of these devices [2,4,5], we show how kinematic redundancy can be used

to resolve dynamic issues. In particular, we develop and apply a methodology for using kinematic redundancy to minimize the magnitude of the base reactions generated by the motion of the manipulator in space.

2.0 Outline of Contents

The paper is organized as follows. In the next section, we formally define the problem of minimizing the magnitude of the base reactions. The basic approach to solving the problem is defined in Section 4. The approach consists of two parts:

1. generation of the end-effector trajectory (Section 5)
2. solution of the inverse-kinematic problem for the joint trajectories (Section 6).

In Section 6 we pose the optimization problem of minimizing the magnitude of the base reactions in order to obtain the unique inverse-kinematic solution. The algorithm, used to implement the methodology developed in Sections 5 and 6, is described in Section 7. The application of the methodology to minimizing the base reactions of a four degree-of-freedom spatial manipulator (with one redundant degree-of-freedom) is demonstrated in Section 8. Finally, in the last section, we draw some conclusions and summarize our work.

3.0 Problem Statement

In this section we describe the trajectory planning problem for redundant manipulators. Consider a m degrees of freedom redundant manipulator with m revolute or prismatic joints mounted to a base. The base of the manipulator can be considered as part of the spacecraft or space station.

In general let q_i denote the joint displacement of joint i . The joint variable of each joint is either an angle θ_i (revolute joint) or a distance d_i (prismatic joint). The joint displacement vector \mathbf{q} can be defined as

$$\mathbf{q} = [q_1, q_2, \dots, q_m]^T$$

Let E be an arbitrary point on the end effector as shown in Figure 1. The position of E can be represented with reference to the coordinate frame xyz fixed in the base by

$$\mathbf{r} = [x \ y \ z]^T \tag{1}$$

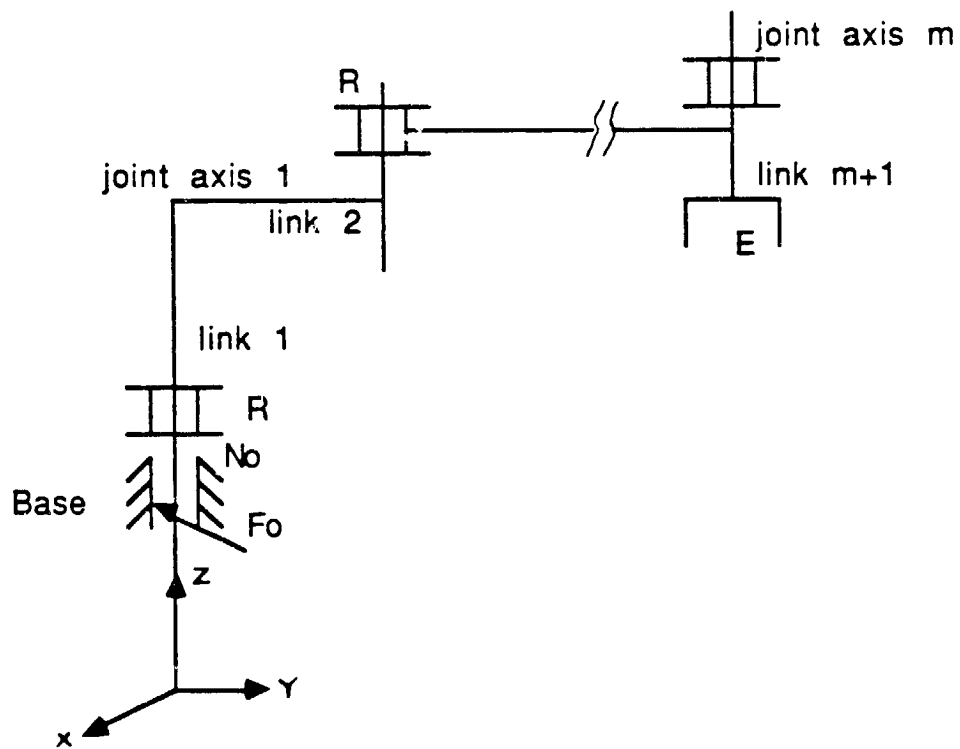

Figure 1. A m DOF Redundant Manipulator

The kinematic equations relating the end-effector position and the joint displacement variables are given by

$$r(t) = g(q(t)) \quad (2)$$

where g is the vector of functions which are nonlinear in $q(t)$.

For a redundant manipulator, the number degrees of freedom, m is more than the minimum number degrees of freedom required to perform a task which is denoted by n . Therefore, there are an infinite number of joint space solutions $q(t)$ for a specified end-effector position, $r(t)$. From these solutions, we can select a joint space solution based on certain criteria. In this paper we use the minimization of the base reactions as the criterion to select appropriate joint space solution.

The trajectory planning problem studied in this paper is restricted to point-to-point motion. In a point-to-point motion, the objective is to move the end-effector of a manipulator from a starting position, r_i to a final position, r_f . During the execution of point-to-point motion, the base force (F_o) and base moment (N_o) exerted by the manipulator on the base cause undesired linear and angular motions of the supporting structures. Ideally, one would desire the base reactions to be zero. Since in reality this objective may not be achievable, we seek instead to minimize the magnitude of the base reactions.

The trajectory planning problem for redundant manipulators which we are going to address has two requirements: (1) to move a redundant manipulator according to specified motion requirements; (2) to minimize the magnitude of the base reactions (N_o and F_o) transmitted by the manipulator to the base during motion.

4.0 Description of the Approach

The basic approach to the trajectory planning problem was described in [7,8] and consists of splitting the problem into two parts which enables us to deal with the end-effector trajectory and joint trajectories separately.

The first part, described in Section 5, deals with the generation of the end-effector trajectory to satisfy certain motion constraints. The motion constraints of interest are the maximum acceleration of the end-effector trajectory and the total time of the task.

In Section 6, we discuss the second part of the approach. The basic idea is to pose the inverse kinematics problem for determining the joint trajectories as an optimization problem with a cost function that is a measure of the base reactions. The approach begins by partitioning the joint variable vector, q into a set of redundant joint variables and a set of nonredundant joint variables. This enables us to work with a square Jacobian matrix as in the nonredundant manipulator case. Then the Jacobian matrix is partitioned into a nonsingular square Jacobian matrix associated with nonredundant joint variables and a submatrix associated with redundant joint variables. Using these partitioned matrices, we are able to represent the motion of all the joints in terms of an optimization parameter matrix. The unique inverse kinematic solution can then be determined by finding the optimal parameter matrix for the optimization problem.

5.0 Part 1- Generation of End-effector Trajectory

Trajectory planning for a manipulator can be conducted in joint space or task space. However in order to take advantage of the redundant kinematics, it is beneficial to specify the end-effector trajectory in task space.

Let the velocity, v and acceleration, \dot{v} of the end effector be defined as:

$$v = \dot{r}$$

$$\dot{v} = \ddot{r}$$

Consider the motion of an end-effector moving from a specified starting position, $r_i(t)$ to a specified final position, $r_f(t)$. There are many ways to execute this motion. A simple way is to move the end effector along a straight-line path that connects the two points. To describe this trajectory, the time histories of the position, velocity, and acceleration of the end-effector in the task-space have to be specified. They can be described by smooth and simple functions.

One of the constraints in trajectory planning is to have zero velocity at the initial and final positions. Cycloid curve which satisfies this requirement can be used to describe the linear speed of the end-effector trajectory. Furthermore, it is a smooth function and can be defined by three constants (a, b, c). Using cycloid representation, the linear speed of the trajectory is given by

$$v(p) = b(1 - \cos p) \tag{3}$$

where p is the parameter ($0 \leq p \leq 2\pi$). When $p = 0$, the end effector is at the initial position, r_i . And when $p = 2\pi$, the end-effector reaches the final position, r_f .

The parameter p can be related to the time of the motion by

$$t = a (p - c \sin p) \quad (4)$$

The distance traversed by the end-effector, d can be obtained by integrating Eqn. (3) with respect to time.

$$d = a b [(1 + 0.5 c) p - (c + 1) \sin p + 0.25 c \sin 2p] \quad (5)$$

The magnitude of linear acceleration, \dot{v} is obtained by differentiating Eqns. (3) and (4) :

$$\dot{v}(p) = \frac{b \sin p}{a(1-c \cos p)} \quad (6)$$

The magnitude of the maximum acceleration is

$$|\dot{v}_{\max}| = \frac{b}{a(1-c^2)^{0.5}} \quad (6a)$$

which occurs at the instant given by

$$p_{\max} = \cos^{-1} c$$

The three constants a , b , and c can be determined by forcing the cycloid curve to satisfy three motion constraints - total distance traversed, total time of the task, and the maximum acceleration magnitude. In other words, we can obtain these constants by solving Eqn. (6) and the following equations:

$$T \text{ (total time)} = 2 \pi a \quad (7)$$

$$D \text{ (total distance)} = |r_f - r_i| = ab(2 + c) \pi \quad (8)$$

After these constants are determined, the position vector, r can be obtained by

$$\mathbf{r} = \mathbf{r}_i + d \mathbf{u} \quad (9)$$

where \mathbf{u} is a unit vector which points from the initial position to the final position and d is defined in Eqn. (5).

Similarly, the velocity and acceleration of the end-effector are

$$\mathbf{v} = \dot{\mathbf{v}} \mathbf{u}$$

$$\dot{\mathbf{v}} = \dot{\dot{\mathbf{v}}} \mathbf{u}$$

where $\dot{\mathbf{v}}$ and $\dot{\dot{\mathbf{v}}}$ are given by Eqns. (3) and (6).

6.0 Part 2 - Joint Space Solution

Once the end-effector position, $\mathbf{r}(t)$ is defined, the minimization of base reactions reduces to determining the joint space solution, $\mathbf{q}(t)$ that minimizes the base reactions.

In this section, we develop kinematics relations that are used in formulating the optimization problem for minimizing base reactions. Then we describe the optimization scheme.

6.1 Redundancy Resolution

We begin by determining the infinitesimal motion relation between the position vector, $\mathbf{r}(t)$ and joint variable vector, $\mathbf{q}(t)$ for a m degrees of freedom redundant manipulator. This relation will be useful in finding the joint space solution. For a given desired change in $\mathbf{r}(t)$, $\Delta \mathbf{r}$ the required change in $\mathbf{q}(t)$, $\Delta \mathbf{q}$ is given by:

$$\Delta \mathbf{r} = \mathbf{J} \Delta \mathbf{q} \quad (10)$$

where $\mathbf{J}(\mathbf{q}) \in \mathbb{R}^{n \times m}$ is known as the Jacobian matrix.

The corresponding velocity vector is

$$\mathbf{v} = \mathbf{J}(\mathbf{q}) \dot{\mathbf{q}} \quad (11)$$

Differentiating Eqn. (11) with respect to time, the acceleration of the end-effector is

$$\dot{v} = J \dot{q} + J \ddot{q} \quad (12)$$

For redundant manipulators, the Jacobian matrix, J is not a square matrix. In order to obtain joint variables solution we have to resort to the generalized inverse approach [5]. We break up the joint vector q into the following two sets:

- a) a set of n independent joint variables denoted by q_n and
- b) a set of $(m-n)$ "redundant" joint variables denoted by q_r . Thus the joint variable q can be written as:

$$q = \begin{bmatrix} q_n \\ q_r \end{bmatrix} \quad (13)$$

Similarly, the Jacobian matrix, J can be partitioned as follows :

$$J = [J_n \ J_r] \quad (14)$$

where J_n = a nonsingular $n \times n$ matrix corresponding to q_n and
 J_r = a submatrix $n \times (m-n)$ matrix corresponding to q_r .

q_r is arbitrarily chosen so that J_n is always invertible (nonsingular). Substituting partitioned J and q in Eqns. (10), (11), and (12), they become:

$$\Delta r = J_n \Delta q_n + J_r \Delta q_r \quad (15)$$

$$v = J_n \dot{q}_n + J_r \dot{q}_r \quad (16)$$

$$\dot{v} = J_n \dot{\dot{q}}_n + J_r \dot{\dot{q}}_r + J_n \ddot{q}_n + J_r \ddot{q}_r \quad (17)$$

Rearrange Eqns. (15-17) we have

$$\Delta q_n = J_n^{-1} (\Delta r - J_r \Delta q_r) \quad (18)$$

$$\dot{q}_n = J_n^{-1} (v - J_r \dot{q}_r) \quad (19)$$

$$\ddot{q}_n = J_n^{-1} (\dot{v} - \dot{J}_r \dot{q}_r - J_n \ddot{q}_n - J_r \ddot{q}_r) \quad (20)$$

Eqns. (18-20) express the motion of the nonredundant joint variables, q_n in terms of the motion of the

redundant joint variables, q_r .

6.2 Optimization Problem Formulation

The end-effector trajectory can be divided into a number of segments. For convenience, assume that the duration of each step is the same even though this assumption is not essential to the scheme described below.

The joint trajectory at the end of an arbitrary step can be expressed as :

$$q = q_0 + \begin{bmatrix} \Delta q_n \\ \Delta q_r \end{bmatrix} \quad (21)$$

in which q_0 = the value of q at the start of the time step.

Substituting Eqn. (18) in Eqn. (21), we have

$$q = q_0 + \begin{bmatrix} J_n^{-1} \\ 0 \end{bmatrix}_0 \Delta r + \begin{bmatrix} -J_n J_r \\ I \end{bmatrix}_0 \Delta q_r \quad (22)$$

Note that the subscript []₀ denotes quantities evaluated at the known starting point (q_0) of the step and I denotes an identity matrix of size $(m-n) \times (m-n)$.

For the purpose of optimization, we express the rates of change of redundant joint variables, q_{ri} as

$$\begin{aligned} \dot{q}_{r1} &= c_{11} f_1(t) + c_{12} f_2(t) + \dots + c_{1k} f_k(t) \\ \dot{q}_{r2} &= c_{21} f_1(t) + c_{22} f_2(t) + \dots + c_{2k} f_k(t) \\ &\dots \dots \dots \\ \dot{q}_{r(m-n)} &= c_{(m-n)1} f_1(t) + c_{(m-n)2} f_2(t) + \dots + c_{(m-n)k} f_k(t) \end{aligned} \quad (23)$$

where

c_{ij} = optimization parameters

f_i = shape functions.

Or in matrix form,

$$\dot{\mathbf{q}}_r = \mathbf{C} \mathbf{f}(t) \quad (24)$$

where \mathbf{C} is the matrix of optimization parameters, C_{ij} and $\mathbf{f}(t)$ is the column vector of shape functions.

For convenience, polynomials in t are chosen for $\mathbf{f}(t)$

$$\mathbf{f}(t) = [1 \ t \ t^2 \ t^3 \ \dots \ t^k]^T \quad (25)$$

where k is the degree of the polynomial.

Substituting Eqn. (24) in Eqns. (18 - 20), we have

$$\mathbf{q} = \mathbf{q}_0 + \begin{bmatrix} \mathbf{J}_n^{-1} \\ 0 \end{bmatrix}_0 \Delta r + \begin{bmatrix} -\mathbf{J}_n \mathbf{J}_r \\ 1 \end{bmatrix}_0 \mathbf{C} \mathbf{f} \Delta t \quad (26)$$

$$\dot{\mathbf{q}}_n = \mathbf{J}_n^{-1} (\mathbf{v} - \mathbf{J}_r \mathbf{C} \mathbf{f}) \quad (27)$$

$$\ddot{\mathbf{q}}_n = \mathbf{J}_n^{-1} [\dot{\mathbf{v}} - \dot{\mathbf{J}}_r \mathbf{C} \mathbf{f} - \mathbf{J}_n \mathbf{J}_n^{-1} (\mathbf{v} - \mathbf{J}_r \mathbf{C} \mathbf{f}) - \mathbf{J}_r \mathbf{C} \dot{\mathbf{f}}] \quad (28)$$

Now, we can describe the motion of all the joint variables, $\mathbf{q}(t)$ by specifying the values of \mathbf{C} matrix. For a particular manipulator configuration, the base reactions (\mathbf{F}_0 and \mathbf{N}_0) for the end of that time step are dependent on the impending motions of all the joints which by Eqns. (24 - 28) are functions of the \mathbf{C} matrix.

Recursive Newton-Euler dynamics formulation [9] is employed to obtain the base reactions. It consists of a set of forward and backward recursive equations. The recursive forward equations are used to compute linear velocity and acceleration, angular velocity and acceleration of each joint variable, proceeding from joint 1 to joint m . The backward recursive equations are used to compute the forces and moments exerted on each joint, starting from joint m and back to joint 1. Once the moments and forces exerted on joint 1 are computed, the base reactions (\mathbf{F}_0 and \mathbf{N}_0) can then be determined.

6.3 Cost Function

The problem of minimizing the magnitude of the base reactions is essentially one of minimizing a suitable cost function, B which is a measure of the base reactions \mathbf{F}_0 and \mathbf{N}_0 .

In general, the magnitude of base reaction force is given by

$$F_0^2 = F_{01}^2 + F_{02}^2 + F_{03}^2 \quad (29)$$

and the magnitude of base reaction moment is

$$N_0^2 = N_{01}^2 + N_{02}^2 + N_{03}^2 \quad (30)$$

We introduce two weighting factors (w_1 and w_2) that enable us to place different weights on base force component and base moment components. Now, we can define a cost function, B that is a measure of the base reactions,

$$B = w_1 F_0^2 + w_2 N_0^2$$

Or in matrix form,

$$B = [F_0 \ N_0] \begin{bmatrix} w_1 I & 0 \\ 0 & w_2 I \end{bmatrix} [F_c \ N_c]^T \quad (31)$$

If we choose $R = [F_0 \ N_0]^T$ and $Q = \begin{bmatrix} w_1 I & 0 \\ 0 & w_2 I \end{bmatrix}$

the cost function B becomes

$$B = R^T Q R. \quad (32)$$

Note: The weights w_1 and w_2 must be carefully chosen to:

- (a) appropriately scale the base reactions with respect to a reference set of base reactions and
- (b) ensure that all terms in the cost function are dimensionally homogeneous.

In the example of Section 8, we demonstrate one way of choosing w_1 and w_2 to satisfy the above requirements.

6.4 Optimization Scheme

The optimization problem for minimizing the magnitude of the base reactions is the following: determine the optimization parameter matrix \mathbf{C} which minimizes $B = \mathbf{R}^T \mathbf{Q} \mathbf{R}$. The above optimization problem is solved using the following scheme:

1. Divide the end-effector trajectory $\mathbf{r}(t)$ into a sufficiently large number of segments.
2. For a known initial configuration of the manipulator, obtain \mathbf{C} that will minimize the cost function B at the end point of the segment.
3. Compute the joint trajectory over this segment using Eqn. (26).
4. Go to the next segment of the trajectory and repeat steps 2 and 3. Stop if the end of the trajectory is reached.

6.5 Optimization Technique

In step 2 of the optimization scheme, an unconstrained optimization technique, the Hooke & Jeeves approach [12] is used to obtain the optimal \mathbf{C} for each time step. This algorithm is one of the earliest and most successful direct search methods. It does not require derivatives as in more sophisticated first-order methods. The disadvantage is that it has difficulties with highly constrained problems.

7.0 Algorithm of the Approach

An algorithm of the approach described in sections 5 and 6 and a computer program written in Pascal have been developed to implement the methodology. The flowchart in Figure 2 illustrates the basic algorithm.

The first step of the approach is to find the constants of cycloid curve based on the three motion constraints as outlined in section 5. Then we formulate the optimization problem using the equations developed in previous section. The optimization scheme of Section 6.4 is applied to obtain a unique joint space solution which minimizes the base reactions.

8.0 Illustrative Example

In this section we demonstrate how our approach can be applied to minimize the base reactions of a four degrees of freedom spatial manipulator proposed by NASA for space applications (see Figure 3). For a point-to-point spatial motion, three degrees of freedom are required. Therefore, this manipulator has one degree of redundancy. The manipulator has three links with lengths of l_1 , l_2 , and l_3 respectively. The reference frame $X_b Y_b Z_b$ is located at the base. Link 1 is mounted to the supporting structure and the other two links are each driven by a differential drive mechanism (a traction drive) which has two outputs that

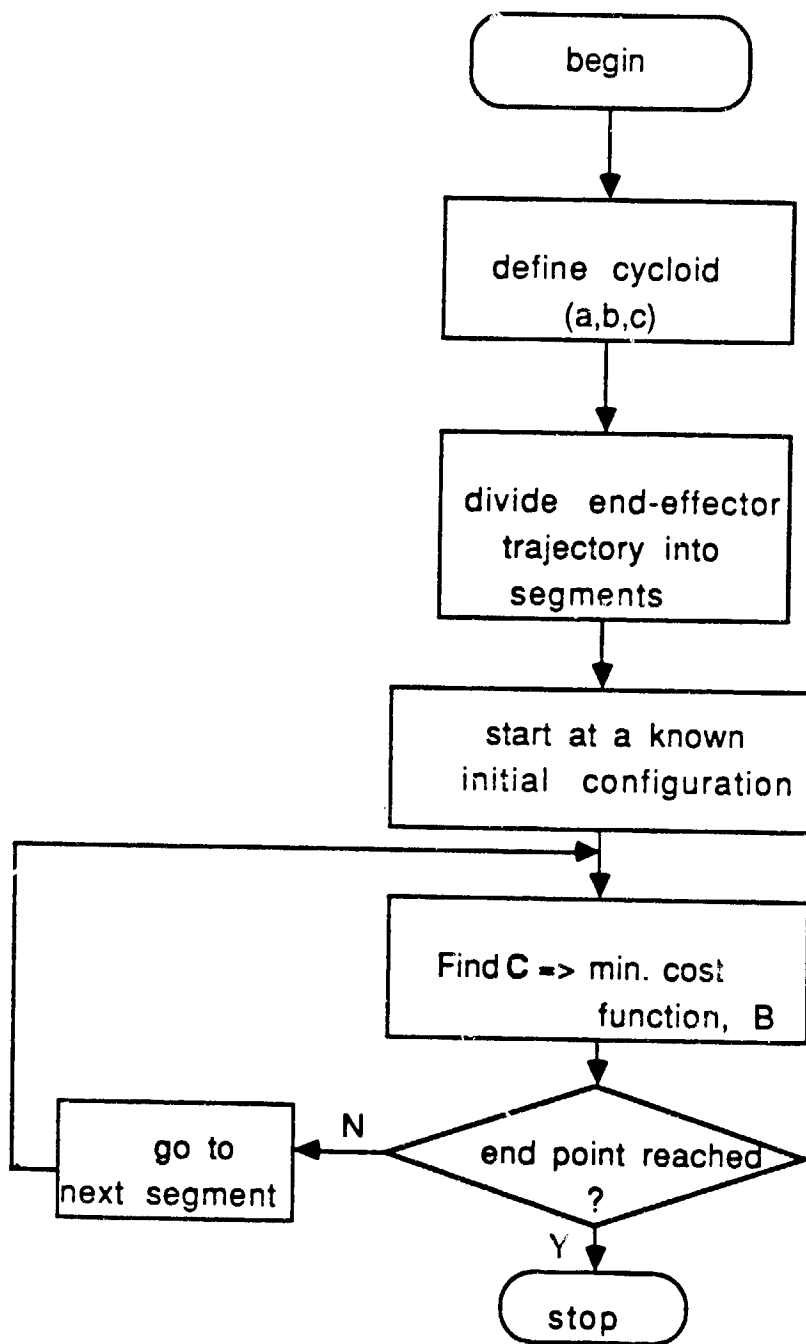

Figure 2. Flowchart of the Algorithm of Trajectory Planning

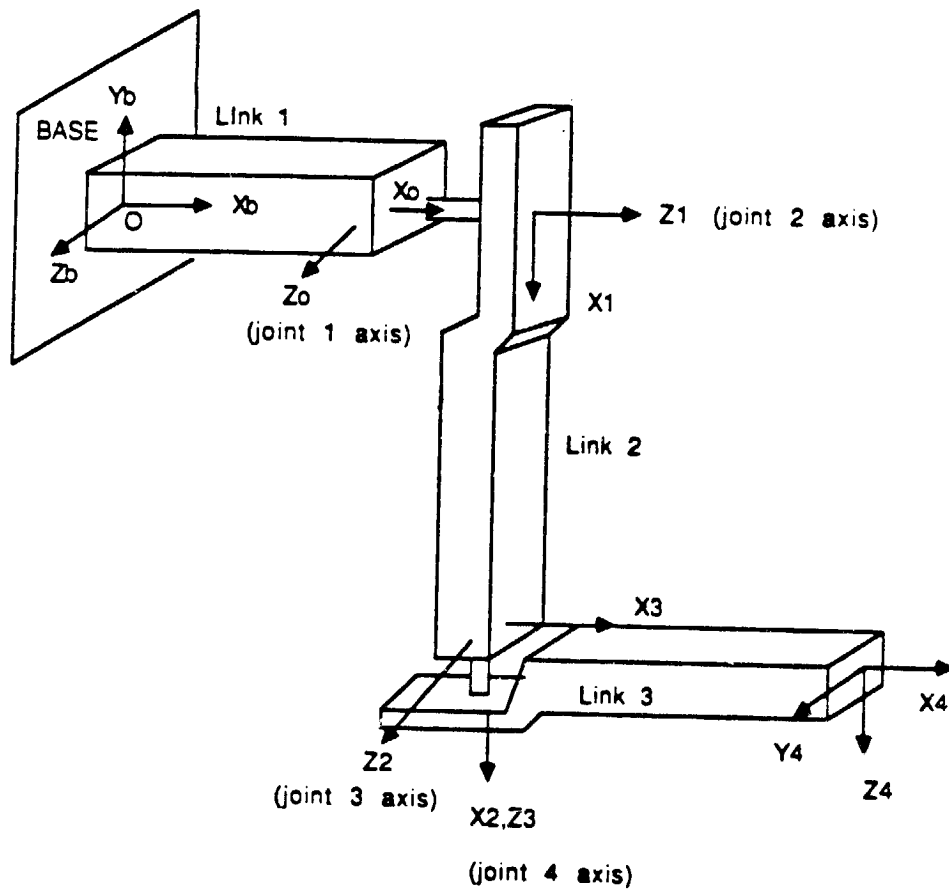

Figure 3. A 4 DOF Spatial Redundant Traction-drive Manipulator

rotate about orthogonal axes. For the purposes of kinematic and dynamic analyses, this differential drive mechanism can be considered as two intersecting revolute joints.

8.1 End-effector Trajectory

For the end-effector trajectory, the following task specifications are chosen:

$$T = 2.0s$$

$$|\dot{v}_{\max}| = 2.0 \text{ m/s}^2$$

$$r_i = [1.5m \ 0.5m \ 0.5m]^T$$

$$r_f = [1.2 \text{ m} \ -0.5m \ 0.2m]^T$$

$$D = |r_f - r_i| = 1.086m.$$

Solving Eqns. (6-8), the parameters for cycloid trajectory are obtained:

$$a = 0.3183$$

$$b = 0.39$$

$$c = 0.79.$$

8.2 Cost Function

To minimize the base reactions properly, it is important to select a suitable weighting matrix, Q for the cost function, $B = R^T Q R$. Therefore, the choices of the values for the two weighting factors (w_1 and w_2) are crucial. To understand the effects of these weighting factors on the base reactions, three cases with different Q matrices are studied:

8.2.1 Case 1

In this case, we want to find out to what extent the base force component can be minimized by ignoring the base moment component i. e. $w_1=1$ and $w_2=0$. The cost function, B is given by

$$B = F_0^2 \tag{33}$$

or in matrix form,

$$B = R^T Q_1 R \tag{34}$$

where

$$Q_1 = \begin{bmatrix} 1 & 0 \\ 0 & 0 \end{bmatrix} \tag{35}$$

8.22 Case 2

In this case we select a cost function that only minimizes base moment component to study how small the base moment can be obtained. The cost function takes the following form:

$$B = N_0^2 \quad (36)$$

The weighting matrix becomes

$$Q_2 = \begin{bmatrix} 0 & 0 \\ 0 & 1 \end{bmatrix} \quad (37)$$

8.23 Case 3

In general, we want to minimize both the base force, F_0 and the base moment, N_0 transmitted to the base. Since F_0 and N_0 are different physical quantities, we require a weighting matrix Q to non-dimensionalize and to appropriately scale the base force and base moment. The results of Cases 1 and 2 are useful in this regard.

The average value of the force (F_0^2) transmitted to the base in Case 1, F_{avg}^2 is an indicator of small we can reduce the base force. Similarly, the average value of the moment transmitted to the base in Case 2, N_{avg}^2 measures how small we can reduce the base moment. We therefore choose,

$$B = f_0^2 / f_{avg}^2 + N_0^2 / N_{avg}^2. \quad (38)$$

The weighting matrix is given by

$$Q_3 = \begin{bmatrix} w_1 I & 0 \\ 0 & w_2 I \end{bmatrix} \quad (39)$$

where $w_1 = 1/F_{avg}^2 = \text{average of } F_0^T F_0 \text{ in Case 1 and,}$

$w_2 = 1/N_{avg}^2 = \text{average of } N_0^T N_0 \text{ in Case 2.}$

Note that the above choices of w_1 and w_2 simultaneously achieve the desired scaling and non-dimensionalization.

8.3 Optimization Scheme

Using the methodology developed in section 6 we can formulate the base reactions optimization problem for the example using the following procedures:

1. Select q_1 as the redundant joint variable.

$$q_r = q_1 \quad (40)$$

$$q_n = [q_2 \ q_3]^T \quad (41)$$

Using Eqn. (24) we can represent the rate of change of joint 1 by

$$\dot{q}_1 = c_0 + c_1 t \quad (42)$$

2. Then partition J into J_n and J_r (see Appendix for detailed expressions)
3. Substituting q_r in Eqns (26-28) we have a complete description of the joint trajectories.
4. Apply the optimization scheme outlined in section 6 with $\Delta t = 0.1s$.

8.4 Discussion of Results

The magnitudes of the base reactions corresponding to the above three cost functions are illustrated in Figures 4 and 5. In Figure 4 the base forces for all three cases are shown. The base force in Case 1 is the smallest among the three cases. This is expected as in Case 1 only the magnitude of the base force is minimized. In Case 2 where only moment component is weighted, we have the largest base force. The magnitude of base force in Case 3 (where we minimize the scaled and weighted sum of F_0 and N_0) lies in between Cases 1 and 2.

Figure 5 shows the base moment for all three cases. For case 1, we have a peak in base moment at $t=1.2s$. But in Cases 2 and 3 better results are observed. This indicates that the cost function must include a suitably weighted base moment.

From results of these three different case studies, the cost function that weights both the base force and base moment is obviously a suitable choice for properly minimizing base reactions. The results of Figures 4 and 5 also indicate that the weights w_1 and w_2 given by Eqn. (39) are good choices for minimization of B.

The end-effector trajectory generated using cycloid curve is shown in Figures 6-8. In Figure 9, the time history of the redundant joint variable, q_1 is also shown. Note the joint trajectory obtained using our

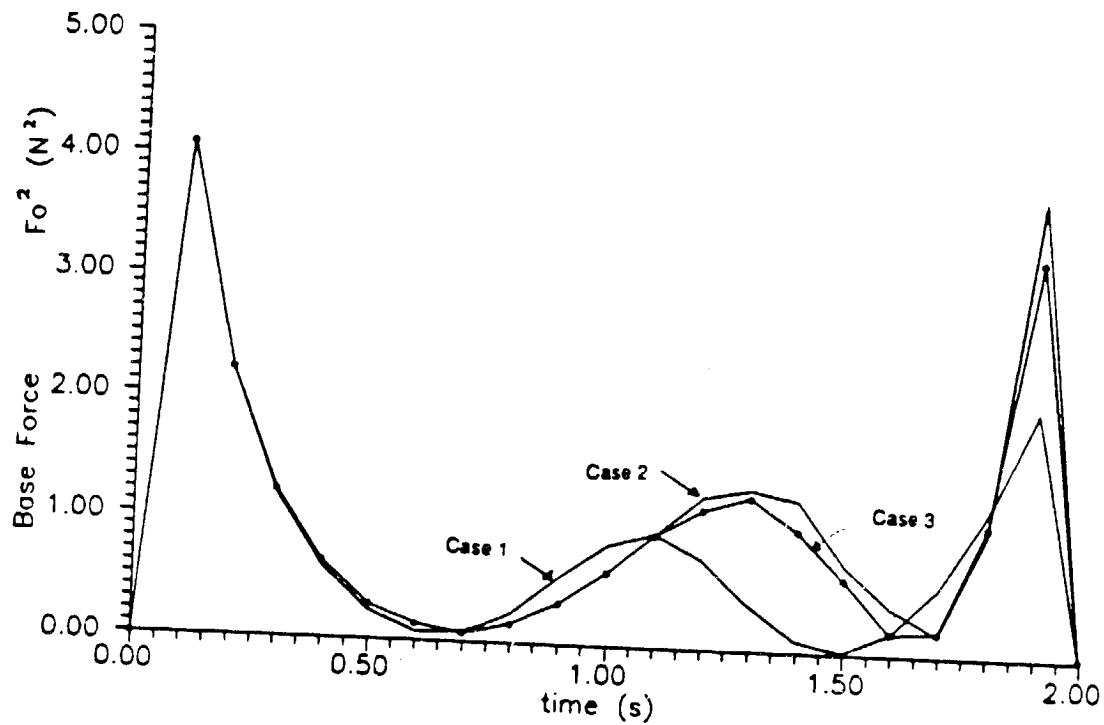

Figure 4. Optimized Magnitude of Base Force

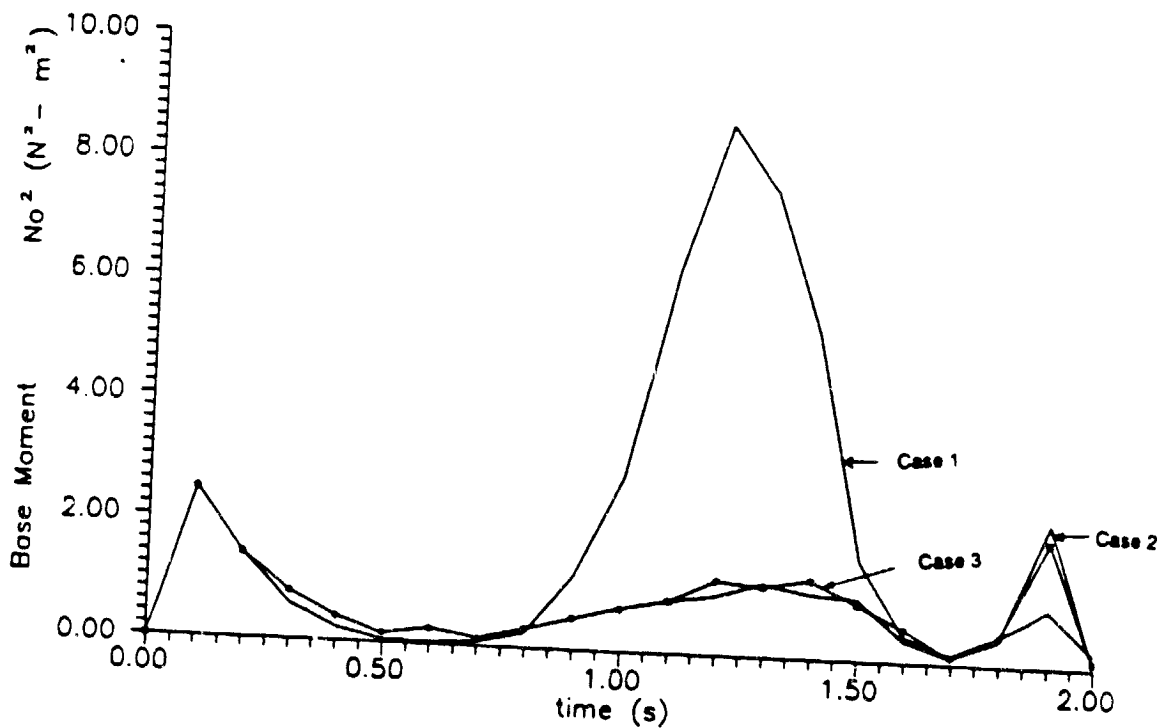

Figure 5. Optimized Magnitude of Base moment

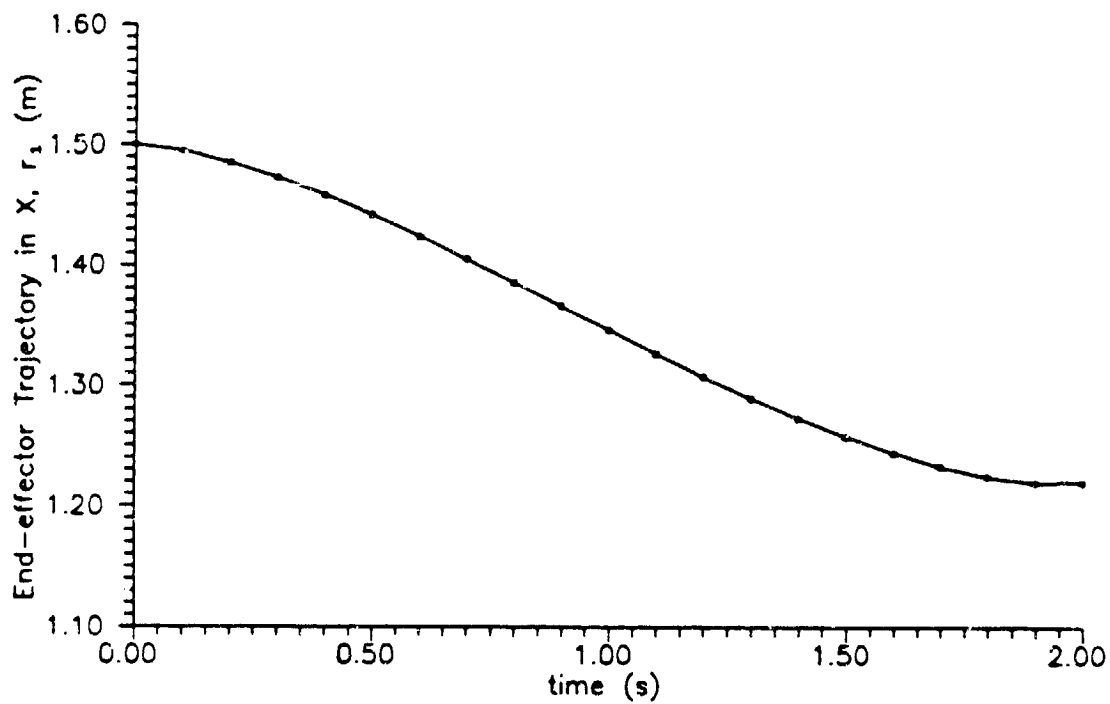

Figure 6. Time History of End-effector Trajectory (x-component)

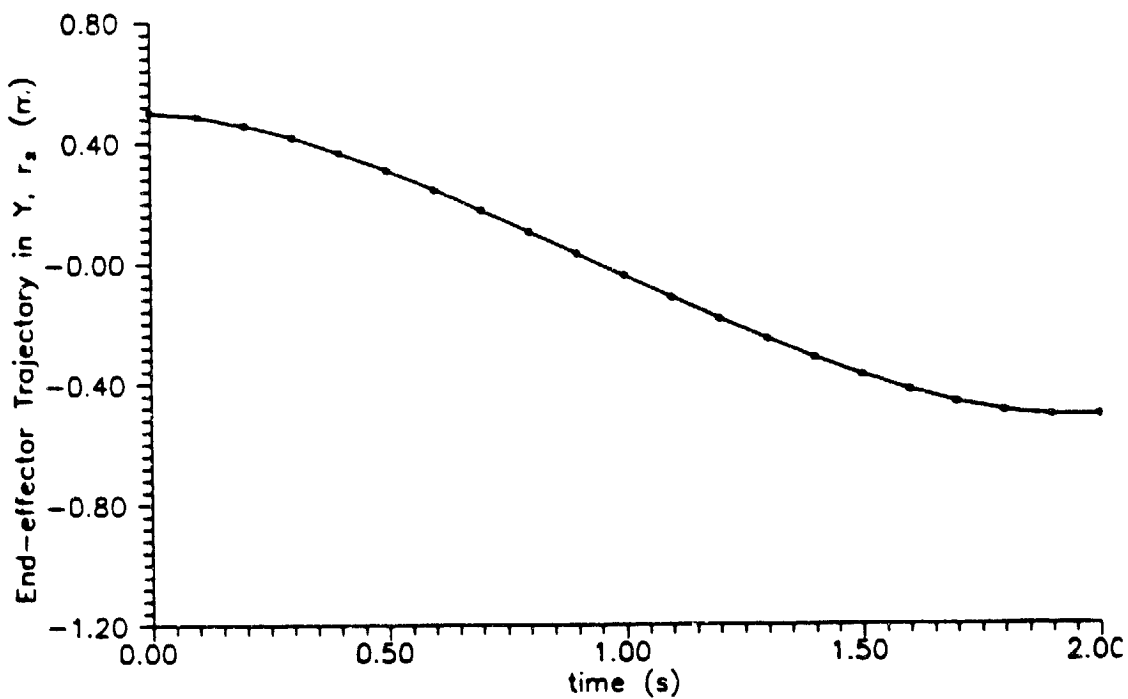

Figure 7. Time History of End-effector Trajectory (y-component)

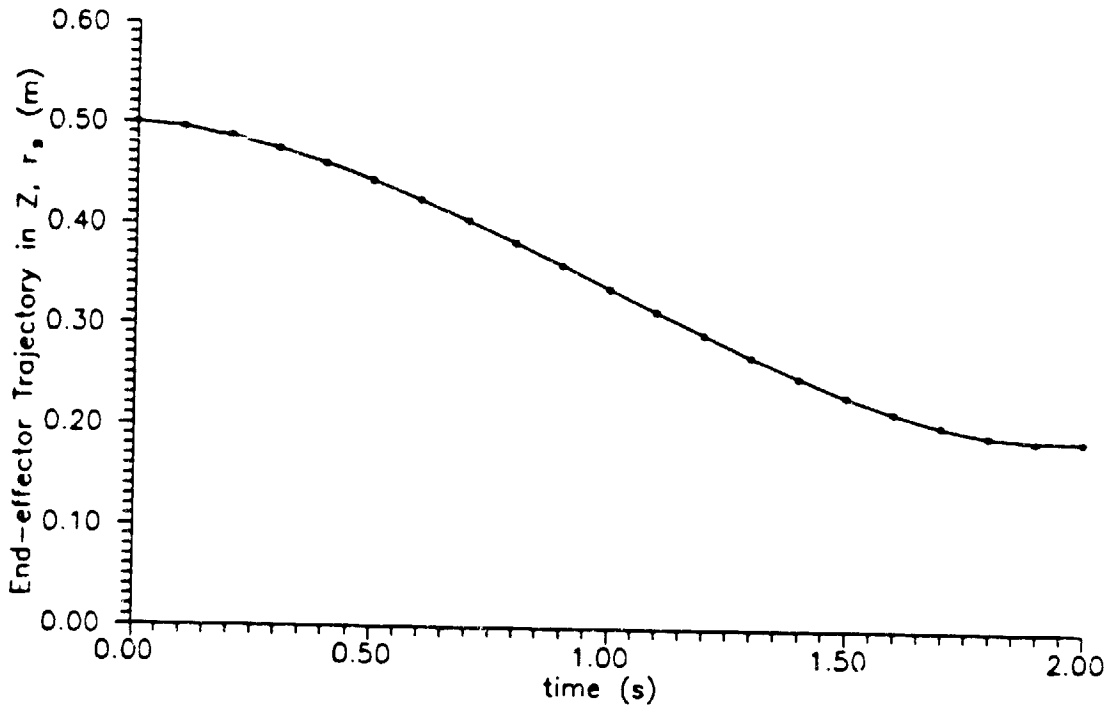

Figure 8. Time History of End-effector Trajectory (z-component)

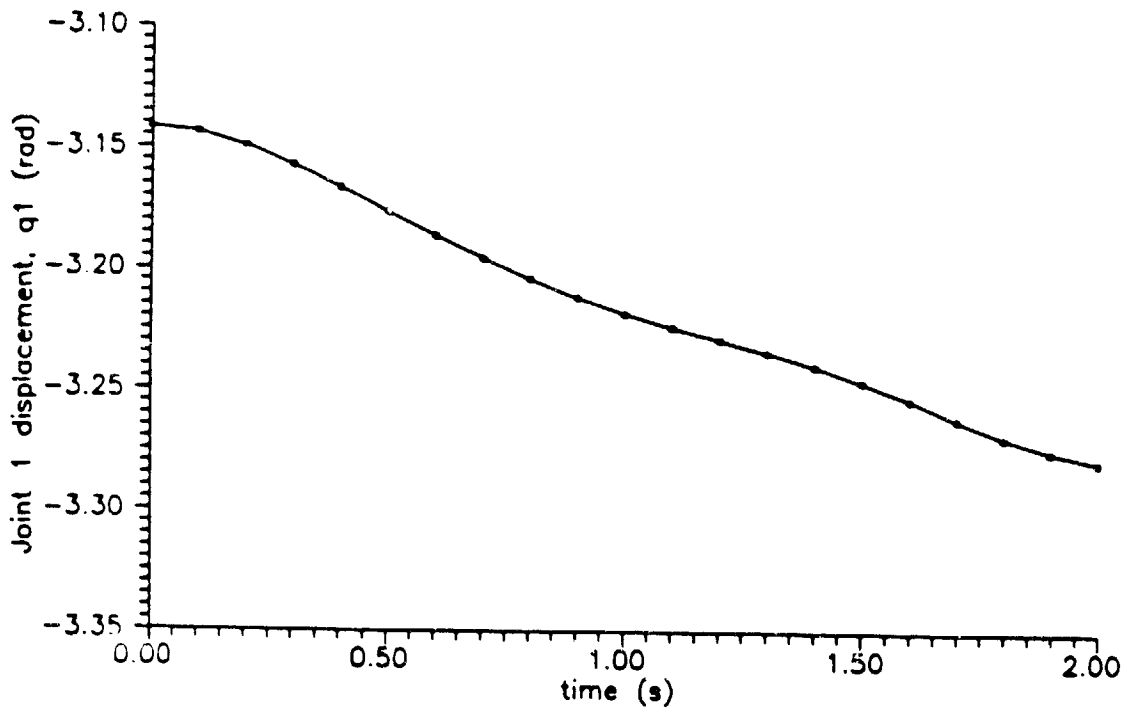

Figure 9. Optimal Joint Trajectory (q_1) of Case 3

algorithm is smooth.

9.0 Conclusions

In this paper, we have shown how kinematic redundancy can be employed in planning joint trajectories to minimize the base reactions exerted by the manipulator on the supporting space structure. Using the approach proposed in this paper the joint trajectories are obtained by minimizing a quadratic cost function which is a measure of the magnitude of the base reactions. From the results obtained, we observe that the cost function which weights both the base force and base moment as given by Eqns. (38-39) is most suitable for minimizing the base reactions.

The major advantage of this approach is that the cost function can either be an analytical expression (i.e. explicit) or computed from other formulations e.g., Newton-Euler dynamic Formulations (i.e. implicit).

The disadvantage of this approach is that it is computationally intensive and hence time consuming because an optimization routine is required to find the optimal joint trajectories. One possible solution is to use an optimization technique with a faster convergence rate.

We have posed an optimization problem which minimizes the cost function

$$B = R^T Q R$$

at every instant of time. It is probably useful to compare the present approach with the use of an "integral" cost function, for example

$$B = \int R^T Q R dt$$

over a time interval of interest. In the case of the "integral" cost function we would be minimizing the average magnitude of the base-reactions. We also need to explore the effect of the choice of the end-effector trajectory on the magnitude of the base reactions: in the present work we choose a cycloid as it meets all our motion constraints.

In summary, we have demonstrated the feasibility of using kinematic redundancy to solve the dynamic problem of minimizing base reactions.

Acknowledgement

NASA Lewis Research Center provides financial support for this work through contract NAG3-811.

Appendix : Kinematics Analysis

The manipulator of interest is shown in Figure 3. Links 2 and 3 are each driven by a 2 DOF traction drive joint. The coordinate frame $X_4Y_4Z_4$ represents the position and orientation of the end effector. The coordinate systems in Figure 3 are assigned according to Denavit-Hartenberg notation [10]. The axis about which a link rotates is defined as the z-axis and the corresponding joint variable is q_i . An A_i ($i=1,2,3,4$) matrix is used to describe the relative position and orientation between two link coordinate frames. The position and orientation of the end effector with respect to the base coordinate frame described by the matrix T_4 which is given by

$$T_4 = A_0 A_1(q_1) A_2(q_2) A_3(q_3) A_4(q_4) \quad (A.1)$$

$$= \begin{bmatrix} n & o & a & p \\ 0 & 0 & 0 & 1 \end{bmatrix}$$

where $q_1, q_2, q_3,$ and q_4 are the joint variables of joint 1 to joint 4 respectively,

$[n \ o \ a]$ = orientation matrix of the $X_4Y_4Z_4$ with respect to the base coordinate frame $X_bY_bZ_b$. It is the upper left 3x3 partitioned matrix of T_4 , and

p = position vector which points from the origin of the base coordinate frame to the origin of the $X_4Y_4Z_4$ frame.

The following shorthand notations of sine and cosine of joint variables will be used.

$$S_i = \sin(q_i), \quad C_i = \cos(q_i), \quad S_{ij} = \sin(q_i + q_j), \quad C_{ij} = \cos(q_i + q_j)$$

It can be shown that for this manipulator, the homogeneous transformation matrices ($A_i, i=0,1, \dots,4$) are

$$A_0 = \begin{bmatrix} 1 & 0 & 0 & l_1 \\ 0 & 1 & 0 & 0 \\ 0 & 0 & 1 & 0 \\ 0 & 0 & 0 & 1 \end{bmatrix} \quad (A.2)$$

$$A_1 = \begin{bmatrix} C_1 & 0 & -S_1 & 0 \\ S_1 & 0 & C_1 & 0 \\ 0 & -1 & 0 & 0 \\ 0 & 0 & 0 & 1 \end{bmatrix} \quad (A.3)$$

$$A_2 = \begin{bmatrix} C_2 & 0 & S_2 & I_2 C_2 \\ S_2 & 0 & -C_2 & I_2 S_2 \\ 0 & 1 & 0 & 0 \\ 0 & 0 & 0 & 1 \end{bmatrix} \quad (A.4)$$

$$A_3 = \begin{bmatrix} C_3 & 0 & S_3 & 0 \\ S_3 & 0 & -C_3 & 0 \\ 0 & 1 & 0 & 0 \\ 0 & 0 & 0 & 1 \end{bmatrix} \quad (A.5)$$

$$A_4 = \begin{bmatrix} C_4 & -S_4 & 0 & I_3 C_4 \\ S_4 & C_4 & 0 & I_3 S_4 \\ 0 & 0 & 1 & 0 \\ 0 & 0 & 0 & 1 \end{bmatrix} \quad (A.6)$$

Performing matrix multiplications, T_4 in Eqn. (A.1) is given by

$$T_4 = \begin{bmatrix} n_x & o_x & a_x & P_x \\ n_y & o_y & a_y & P_y \\ n_z & o_z & a_z & P_z \\ 0 & 0 & 0 & 1 \end{bmatrix} \quad (A.7)$$

where

$$\begin{aligned} n_x &= C_1(C_2 C_3 C_4 + S_2 S_4) - S_1 S_3 C_4 \\ n_y &= S_1(C_2 C_3 C_4 + S_2 S_4) + C_1 S_3 C_4 \\ n_z &= -S_2 C_3 C_4 + C_2 S_4 \\ o_x &= C_1(S_2 C_4 - C_3 C_2 S_4) + S_1 S_3 S_4 \\ o_y &= S_1(S_2 C_4 - C_3 C_2 S_4) - C_1 S_3 S_4 \\ o_z &= S_2 C_3 S_4 + C_2 C_4 \\ a_x &= C_1 C_2 S_3 + S_1 C_3 \\ a_y &= S_1 C_2 S_3 - C_1 C_3 \\ a_z &= -S_2 S_3 \\ P_x &= C_1[l_3(C_2 C_3 C_4 + S_2 S_4) + l_2 C_2] - l_3 C_4 S_1 + l_1 \\ P_y &= S_1[l_3(C_2 C_3 C_4 + S_2 S_4) + l_2 C_2] + l_3 C_4 S_3 C_1 \\ P_z &= l_3(C_2 S_4 - S_2 C_3 C_4) - l_2 S_2 \end{aligned}$$

If joint 1 is chosen to be the redundant joint, we have

$$q_r = q_1 \quad (A.8)$$

and the partitioned Jacobian matrices J_n and J_r are

$$J_n = \begin{bmatrix} l_3(C_1 C_2 S_4 - C_1 S_2 C_3 C_4) - L_2 C_1 S_2 & -l_3(C_1 C_2 S_3 C_4 + S_1 C_3 C_4) \\ l_3(S_1 C_2 S_4 - S_1 S_2 C_3 C_4) - L_2 S_1 S_2 & l_3(C_1 C_3 C_4 - S_1 C_2 S_3 C_4) \\ -l_3(S_2 S_4 + C_2 C_3 C_4) - L_2 C_2 & l_3 S_2 S_3 C_4 \end{bmatrix}$$

$$\begin{bmatrix} 1/3(C_1S_2C_4 - C_1C_2C_3S_4 + S_1S_3S_4) \\ 1/3(S_1S_2C_4 - S_1C_2C_3S_4 - C_1S_3S_4) \\ 1/3(C_2C_4 + S_2C_3S_4) \end{bmatrix} \quad (A.9)$$

$$J_r = \begin{bmatrix} -1/3(S_1C_2C_3C_4 + S_1S_2S_4 + C_1S_3C_4) - 1/2S_1C_2 \\ 1/3(C_1C_2C_3C_4 + C_1S_2S_4 - S_1S_3C_4) + 1/2C_1C_2 \\ 0 \end{bmatrix} \quad (A.10)$$

References

1. Lerner, E.J., "Robots on the Space Station," *Aerospace America*, June 1987, pp. 42-45.
2. Liegeois, A., "Automatic Supervisory Control of the Configuration and Behavior of Multibody Mechanisms," 1977, *IEEE trans. Systems, Man, Cybern.*, SMC-7, pp.868-871.
3. Hollerbach, J.M., Suh, K.C., "Redundancy Resolution of Manipulators Through Torque Optimization," 1985, *IEEE Int. Conf. on Robotics and Automation*, St. Louis, Missouri.
4. Yoshikawa, T., "Analysis and Control of Robot Manipulators with Redundancy," *Robotics Research: The First Int. Symposium*, ed. M. Brady and R. Paul, Cambridge, Mass., MIT Press.
5. Fenton, R. G., Benhabib, B., and Goldenberg, A. A., "Optimal Point-to-Point Motion of Robots with Redundant Degrees of Freedom," *ASME Journal of Engineering for Industry*, vol. 108, May 1986, pp. 120-126.
6. Nakamura, Y., Hanafusa, H., "Optimal Redundancy Control of Robot Manipulators," *The Int. Journal of Robotics Research*, vol. 6 no.1, spring 87, pp. 32-42.
7. de Silva, C. W., Chung, C. L., and Lawrence, C., "Base Reaction Optimization of Robotics Manipulators for Space Applications", *Proc. Int. Symp. Robots*, Sydney, Australia, November 1988 (accepted).
8. de Silva, C. W., Chung, C. L., and Lawrence, C., "Trajectory Design for Robotic Manipulators in Space Applications", Submitted to the *Int. J. Robotics Research*.
9. Fu, K. S., Gonzalez, R. C., and C. S. G. Lee, *Robotics: Control, Vision, and Intelligence*, McGraw-Hill, 1987.
10. Asada, H., and Slotine, J.J. E., *Robot Analysis and Control*, John Wiley and Sons, New York, 1985.

11. Rao, S. S., *Optimization Theory and Applications*, 2nd ed., John Wiley and Sons, New York, 1984.
12. Siddall, J. N. , *Optimal Engineering Design: Principle and Applications*, Marcel Dekker Inc. , New York, 1982.