

N90-17904

INFRARED THERMAL IMAGING FIGURES OF MERIT

Herbert Kaplan

Honeyhill Technical Company
193 East Avenue, Norwalk, Connecticut 06855

Abstract

This paper will begin with a discussion of commercially available types of infrared thermal imaging instruments, both viewers (qualitative) and imagers (quantitative). The various scanning methods by which thermal images (thermograms) are generated will be reviewed.

The performance parameters (figures of merit) that define the quality of performance of infrared radiation thermometers will be introduced. A discussion of how these parameters are extended and adapted to define the performance of thermal imaging instruments will be provided.

Finally, the significance of each of the key performance parameters of thermal imaging instruments will be reviewed and procedures currently used for testing to verify performance will be outlined.

INFRARED THERMAL IMAGING FIGURES OF MERIT

Introduction

This paper deals with the performance parameters or "figures of merit" of commercially available infrared thermal imaging instruments; how they are defined, how they are specified by the potential user and how the instruments can be tested to assure compliance. From the user's point of view, there are two broad categories of imaging instruments; those that provide quantitative information, generally in terms of target (blackbody equivalent) temperature, and those that provide only a qualitative thermal image. In the discussions to follow the term *imager* will be used to describe the quantitative instrument and the term *viewer* will be used to describe the qualitative instrument.

Since many of these parameters are based on the means by which scanning is accomplished, it is appropriate to review scanning methodology, beginning with point sensing of infrared radiation from a target.

An important advantage of infrared radiation thermometers over contact thermometers is their speed of response. The measured energy travels from the target to the sensor at the speed of light. The response of the instrument can then be in milliseconds or even microseconds. This important feature has allowed the field of infrared radiation thermometry to expand into real time thermal scanning and thermal mapping. When problems in temperature monitoring and control cannot be solved by the measurement of one or several discrete points on a target surface it becomes necessary to spatially scan, that is to move the collecting beam (instantaneous field of view) of the instrument relative to the target. This can be done by moving the target with the instrument fixed or by moving (translating or panning) the instrument, but is more practically accomplished by inserting a movable optical element or elements into the collecting beam. Depending on where these elements are placed the instrument can be made to scan in object space (in front of the primary optical element) or in image space (behind the primary element). Scanning in image space generally provides better resolution uniformity over narrow scanning angles and requires shorter excursions of the scanning elements. Scanning in object space generally allows wider scanning angles and requires wider angular excursions of the scanning elements in order to accomplish this.

Rectilinear scanning

The purpose of spatial scanning is to derive information concerning the distribution of radiant energy over a target scene. Although an almost infinite variety of scanning patterns can be generated using two moving elements, the most common pattern is rectilinear, and this is most often accomplished by two elements each scanning a direction normal to the other. A typical commercially available rectilinear single detector scanner employs two rotating prisms behind the primary lens system (refractive scanning in image space). An alternate approach to scanning using two oscillating mirrors in front of the primary lens (reflective scanning in object space) is also commonly used in commercially available single detector scanners. Both image space scanners and object space scanners can employ refractive or reflective scanning elements or even combinations of both elements. Most commercially available infrared imagers use a fast scan element to scan lines and a slower scan element to scan image frames, both scanning simultaneously in synchronism.

Multidetector scanners

One of the performance limitations of single-detector scanners is that imposed on the trade-off between speed of response and signal-to-noise ratio of the detector. These instruments require high speed cooled photodetectors which are pushed to their performance limits as the desired real-time scanning rate is increased. Multidetector scanners are scanning imagers that reduce the constraints on detector performance by adding detector elements which share the temporal-spatial burden. By varying detector spacing in the focal plane, the instrument designer can accomplish interlace scanning, stepped scanning, serial scanning or various combinations. These scanning improvements allow for faster frame rates with no reduction in signal-to-noise ratio or improve signal-to-noise ratio with no decreases in frame rate.

In one commercially available instrument, the vertical scanning element is entirely eliminated, and an oscillating mirror serves as the horizontal scanning element. A linear detector array is used on which the number of detector elements equals the number of scan lines in the frame, and each detector element always scans its "assigned" line. Certain adjustments, sometimes costly, are required when conventional linear arrays are used. A preamplifier is required for each detector, and the variations in detector characteristics from channel to channel need to be corrected so that thermal response across the image is uniform. The instrument described above is used commercially as a "thermal viewer" with no absolute temperature readout requirements; this makes it quite cost-effective. Otherwise, depending on the stringency of the instrument performance requirements, the cost of the array itself can be quite high, and the requirement for multiple individually matched preamplifiers may make the cost even higher.

In recent years detector mosaics or "staring" arrays have been used successfully for military night vision FLIR (Forward Looking InfraRed) viewers. Each detector element is assigned one display picture element and mechanical scanning is eliminated altogether.

It is important to understand the basic differences between night vision viewers (non-quantitative) and most high performance commercial IR imagers from the point of view of the end user. The purpose of a night vision system is to provide the clearest possible thermal map of the target to an observer with no actual measurement requirements. The purpose of the commercial thermal imager is to provide a high resolution quantitative thermal image of the target to an observer or to a data processing control system. Neither viewers or imagers using detector mosaics are presently available commercially although one staring array viewer is expected to become available soon.

Pyrovidicon viewers

Pyrovidicon thermal viewers are basically video cameras that operate in the infrared and are worth mentioning here as possible cost-effective tools for users who do not require quantitative thermal information. Pyrovidicons are discussed in some detail in the Kaplan paper, "An Update of Commercial Infrared Sensing and Imaging Instruments" (reference 1).

SPRITE technology

Around 1980 the British introduced a new detector that performs time delay and integration within the detector material itself. The SPRITE (Signal Processing in the Element) detector and its incorporation into a high resolution thermal imager are reviewed in the Leftwich paper, "Advanced TV Compatible Thermal Imaging Using the SPRITE Detector" (reference 2). The paper explains:

"It is possible to manufacture SPRITE detector filaments which are equivalent (depending on the applied field) to about 7 to 14 discrete, high D* elements, thus significantly reducing the number of leads to the cold finger and the complexity of the array."

The first commercial imager series using SPRITE technology was introduced in 1987 and is currently available. It is discussed in reference 1.

Performance parameters of two dimensional scanners

The parameters used for assessing the performance of infrared thermal imaging scanners are complex and the methods used for testing performance have generated some controversy among manufacturers and users of these instruments. Since a thermal image is made up of a great number of discrete point measurements, however, many of the performance parameters of infrared thermal imagers are the same as those of radiation thermometers (point sensing infrared radiometers that read out in temperature). Others derive from, or are extensions of, radiation thermometer performance parameters. It should be noted that for users requiring qualitative rather than quantitative thermal images, many of the parameters discussed herein are of no importance.

The following parameters can be used to specify the performance of an infrared (one-color) radiation thermometer:

- o Temperature range: The high and low limits over which the target temperature may vary
- o Absolute accuracy: As related to the NBS (National Bureau of Standards) standard
- o Repeatability: How faithfully a reading is repeated for the same target
- o Temperature sensitivity: The smallest target temperature change the instrument needs to detect
- o Speed of response: How fast the instrument responds to a temperature change at the target surface
- o Target spot size and working distance: The size of the spot on the target to be measured and its distance from the instrument
- o Output requirements: How the output signal is to be utilized
- o Spectral range: The portion of the infrared spectrum over which the instrument will operate
- o Sensor environment: The ambient conditions under which the instrument will operate

For infrared imaging scanners, the ERIM Infrared Handbook (reference 3) provides an extensive table of terms and definitions (section 19.1.2) and a list of specimen specifications (section 19.4.1). The section of the Handbook covering infrared imaging systems does not, however, deal with the imager as a quantitative measurement instrument, and so the performance parameters related with with temperature measurement need to be added. From the user's point of view, some simplifications can be made which result in some acceptable approximations. Bearing these qualifications in mind, the following definitions of the key performance parameters of infrared thermal scanners are offered:

- o Total field of view (TFOV): The image size, in terms of scanning angle. (example: TFOV=20°V x 30°H)
- o Instantaneous field of view (IFOV): The angular projection of the detector element at the target plane: Imaging spatial resolution. (example: IFOV= 2 milliradians)
- o Measurement spatial resolution: (IFOV_{meas}): The spatial resolution describing the minimum target spot size on which an accurate temperature measurement can be made. (example: IFOV_{meas} = 5 milliradians)
- o Frame Rate: The number of times every point on the target is scanned in one second. (example: Frame rate = 30/second)
- o Minimum resolvable temperature (MRT): The smallest blackbody equivalent target temperature difference that can be observed: Temperature sensitivity. (example: MRT=0.1°C @ 30°C target temp.)

It shall be seen that MRT and the terms relating to spatial resolution are interrelated and cannot be considered independently. Other parameters such as spectral ranges, target temperature ranges, accuracy and repeatability and focusing distances are essentially the same as those defined previously for infrared radiation thermometers although they may be expressed differently. "Dynamic range" and "reference level range", for example, are the terms that define the target temperature ranges for thermal imagers. (For thermal viewers parameters relating to temperature range are only applicable in the broadest sense; absolute accuracy and stability parameters are not applicable; MRT is applicable only as an approximation since stability cannot be assured; IFOV_{meas} is not applicable).

Secondary features such as field uniformity and spatial distortion are design parameters, and are assumed to be handled by responsible manufacturers.

A discussion of the significant figures of merit follows:

Temperature range, accuracy and repeatability

Temperature range and absolute accuracy will always be interrelated; for example, the instrument might be expected to measure a range of temperatures from 0 to 200°C with an absolute accuracy $\pm 2^\circ\text{C}$ over the entire range. This could alternately be specified as $\pm 1\%$ absolute accuracy over full scale. Since absolute accuracy is based on traceability to the NBS standard, it is difficult for a manufacturer to comply with a tight specification for absolute accuracy. An absolute accuracy of $\pm 0.5^\circ\text{C} \pm 1\%$ of full scale is about as tight as can be reasonably specified. Repeatability, on the other hand, can be more easily

assured by the manufacturer, and is usually more important to the user. Testing for these parameters can be accomplished quite easily using blackbody reference sources. Commercial thermal imagers are usually provided with tables of temperature calibration data and, where applicable, corrections for atmospheric and ambient conditions.

Temperature sensitivity, MRTD or MRT

Temperature sensitivity is also called "thermal resolution" or "noise equivalent temperature difference" (NETD). For a radiation thermometer, it is the smallest temperature change at the target surface which can be clearly sensed at the output of the instrument. For any given instrument, temperature sensitivity will improve for hotter targets where there is more energy available for the instrument to measure. Any requirement for temperature sensitivity, therefore, should be specified at a particular target temperature, and this should be near the low end of the range of interest. A specified temperature sensitivity of 0.25°C at a target temperature of 25°C, for example, will ensure that the sensitivity of the instrument will be at least that for targets hotter than 25°C. NETD is the minimum equivalent blackbody temperature difference which will create a signal output equal to the steady state noise present in the instrument. This is easily measured electronically on radiation thermometers, but does not provide a satisfactory assessment of imager system performance.

For an imaging system, the term "minimum resolvable temperature" (MRT) or "minimum resolvable temperature difference" (MRTD) defines temperature sensitivity but also implies spatial resolution (IFOV). MRTD is expressed as a function of angular spatial frequency. Testing for MRTD is usually accomplished by means of a subjective procedure developed by the Department of Defense community. This involves selecting the smallest (highest frequency) standard periodic test pattern (four bars, 7:1 length to width aspect ratio) that can be distinguished as a 4 bar contrast target by the observer, and recording the smallest detectable element-to-element temperature difference between two blackbody elements on this pattern. Unlimited viewing time and optimization of controls is allowed and the target is oriented with the bars normal to the fast scan (line scanning) direction. Figure 1 illustrates the setup using an ambient pattern and a heated background. The MRTD curve shown is a function of spatial frequency (cycles/mrad). Additional points on the curve are achieved by changing the pattern size or the distance to the scanner.

Spot size, instantaneous field of view (IFOV), spatial resolution, measurement spatial resolution (IFOV_{meas})

For a radiation thermometer, target spot size (also called spatial resolution) and working distance may be specified as just that; "0.25" at 2 feet" for example, or in more general terms such as field of view angle (10 milliradians, 1 degree, 2 degrees) or a field of view (spot size-to-working distance) ratio (D/15, D/30, D/75). A D/15 ratio means that the instrument measures the emitted energy of a spot one-fifteenth the size of the working distance (3" at 45" for example).

For thermal imagers the instantaneous field of view (IFOV) expresses spatial resolution for imaging purposes but not for measurement purposes. Measurement instantaneous field of view (IFOV_{meas}) expresses spatial resolution for measurement purposes. The modulation transfer function (MTF) is a measure

of IFOV. Modulation is a measure of radiance contrast and is expressed:

$$\text{Modulation} = \frac{L_{\text{max}} - L_{\text{min}}}{L_{\text{max}} + L_{\text{min}}}$$

Modulation transfer is the ratio of the modulation in the observed image to that in the actual object. For any system, MTF will vary with scan angle and background, and will almost always be different when measured along the high speed scanning direction than it is when measured normal to it. For this reason a methodology was established and accepted by manufacturers and users alike to measure the MTF of an imager and, thereby, to verify the spatial resolution for imaging (night vision) purposes. A sample procedure follows for a system where IFOV is specified at 2.0 milliradians using the same setup as illustrated in figure 1:

A standard 4 bar (slit) resolution target (7:1 aspect ratio) with a 0.060" slit width is placed in front of a heated blackbody reference surface at a distance of 30" from the primary optic of the instrument (The ratio of the 0.060" slit width to the 30" working distance is 2 milliradians). The target is centered in the scanned field and oriented so that the fast scan axis is normal to the slit, and the fast scan output signal is monitored. The analog signal value of the 4 peaks (V_{max}), as the slits are scanned, and the analog signal value of the 3 valleys (V_{min}) are recorded using the bar target surface ambient temperature as a base reference. The MTF is $(V_{\text{max}} - V_{\text{min}}) / (V_{\text{max}} + V_{\text{min}})$. If this is at least 0.35 the 2 milliradian IFOV is verified.

There are some disagreements among users and manufacturers regarding the acceptable minimum value of MTF to verify IFOV with values varying between 0.35 and 0.5 depending on the manufacturer and the purpose of the instrument. For most users a tested value of $\text{MTF} \geq 0.35$ for a slit width representing a specified spatial resolution is generally considered sufficient to demonstrate that spatial resolution for imaging purposes.

Both MRTD and MTF are functions of spatial frequency for any given system This is illustrated in figure 2, reprinted from J.M. Lloyd, "Thermal Imaging Systems" (reference 5) for a typical system rated by the manufacturer to be 1 milliradian. The cutoff frequency is where the IFOV equals 1 cycle (one bar and one slit) so that the intersection of the two curves at the half-cutoff frequency represents the actual performance of the system for an MRTD of 1°C. MTF is seen to be about 0.22 for this system.

For measurement purposes, of course, the slit width should, ideally, be increased until the modulation reaches unity. For this reason the MTF method was found to be unsatisfactory for commercial thermal imagers where quantitative temperature measurement and control are often necessary. Another procedure called the "Slit Response Method" was developed for this purpose and is generally accepted for measuring IFOV_{meas}. In this method, illustrated in figure 3, a single variable slit is placed in front of a blackbody source and the slit width is varied until the resultant signal approaches the signal of the blackbody reference. The curve shown is the Slit Response Function (SRF). Since there are other errors in the optics and the 100% level of SRF is approached rather slowly, the slit width at which the SRF reaches 0.9 is usually accepted as the IFOV_{meas}. Figures 1 and 3 are reprinted from the Ohman paper, "Measurement Versus Imaging in Thermography" (reference 4) which provides a detailed description of the Slit Response Method, setup diagrams and a discussion of imaging and measurement spatial resolution figures of merit.

Speed of response and frame rate

Speed of response of a radiation thermometer is generally defined as the time it takes the instrument output to respond to 95% of a step change at the target surface (about 5 time constants). This parameter is not applicable for thermal imagers, where each element of the target surface is scanned so rapidly that the value for an individual element may never reach 95% of the element-to-element contrast during a single frame scan. Frame integration techniques are used to improve measurement precision (and image quality as well) where it is critical.

Frame repetition rate is the measure of data update of a thermal imager. This is not the same as field repetition rate. Manufacturers tend to use fast field rates with not all the scan lines included in any one scan, and then interlace the fields so that it takes multiple fields to complete a full frame. This produces a more flicker-free image and is more pleasing to the eye than scanning full data frames at a slower rate. Frame rate is the number of times per second every element is scanned.

Output capabilities, recording and display features

Output capabilities are generally dependent on the user's needs. For radiation thermometers a wide selection of readout indicators is usually offered. An analog output suitable for recording, monitoring and control is commonly provided. In addition, most manufacturers offer a broad selection of output functions including digital (BCD coded) outputs, high, low, and proportional setpoints, signal peak or valley sensors, sample and hold circuits, and even closed-loop controls for specific applications. Many presently available instruments, even portable hand-held units, include microprocessors that provide many of the above functions on standard models.

For thermal imagers a selection of monochrome and color display capabilities is usually available, as well as videorecording and playback accessories. Display capabilities and software-dependent features such as data and image processing features are not considered performance figures of merit. They are discussed in the Kaplan paper of reference 1.

Spectral performance

The operating spectral range of a radiation thermometer is often critical to its performance. For cooler targets, up to about 500°C, most manufacturers offer instruments operating in the 8-14 μ atmospheric window. For hotter targets shorter operating wavelengths are selected, usually shorter than 3 μ . One reason for choosing shorter wavelengths is that this enables manufacturers to use commonly available and less expensive quartz and glass optics, which have the added benefit of being visibly transparent for more convenient aiming and sighting. Another reason is that estimating emittance incorrectly will result in smaller temperature errors when measurements are made at shorter wavelengths. Spectrally selective instruments employ interference filters to allow only a very specific broad or narrow band of wavelengths to reach the detector. (A combination of a spectrally selective detector and a filter can also be used). This can make the instrument highly selective to a specific material whose temperature is to be measured in the presence of an intervening medium or an interfering background.

The spectral range of operation of a thermal imager, on the other hand, is not usually critical to the user. All commercial thermal imagers operate in either the 2-5 μ or the 8-12 μ atmospheric window, depending on the manufacturer's choice of detector. Filter wheels or slides are usually available so that users can insert special interference filters and perform spectrally selective measurements when necessary.

Despite some manufacturer's claims to the contrary, there is usually little difference in overall performance between an imager operating in the 2-5 μ band and an imager operating in the 8-12 μ band, all other parameters being equal. For a specific application, however, there may be a clear choice. One example of this would be selecting an imager operating in the 2-5 μ band to observe a target through a quartz window. Since quartz is virtually opaque in the 8-12 μ region, there would be no alternative. Another example would be selecting an imager operating in the 8-12 μ band to observe a cool target through a long atmospheric path. Since long path atmospheric absorption is substantially greater in the 2-5 μ window than in the 8-12 μ , the choice would be obvious.

Operating environment

For radiation thermometers, manufacturers offer environmental enclosures when the operating environment is expected to be hostile enough to the sensor to affect its operation. Most commercial thermal viewers are hand-held and will generally operate satisfactorily in any environment that the user can tolerate. Many thermal imagers are intended for laboratory type of operation only and published specifications illustrate this. Most manufacturers, however, package their scanners in rugged portable housings suitable for most factory and field uses. Reference 1 provides a more detailed discussion of this subject.

References

1. H. Kaplan, An Update of Commercial Infrared Sensing and Imaging Instruments, NASA Conference Publication, NCTM Workshop, Pasadena, CA, January, 1989.
2. R.F. Leftwich, Advanced TV Compatible Thermal Imaging Using the SPRITE Detector, SPIE Proceedings Vol. 371, Thermal Infrared Sensing Diagnostics (THERMOSENSE V), Detroit, MI, October, 1982, P. 216.
3. Wolfe, Zissis, "The Infrared Handbook", ERIM, ONR, Dept. of the Navy, 1978.
4. C. Ohman, "Measurement VS Imaging in Thermography, or What is Resolution?", Proceedings of the Fifth Infrared Information Exchange, New Orleans LA, 1985, Book 2, P. 65 (AGEMA Infrared Systems)
5. J.M. Lloyd, "Thermal Imaging Systems", Plenum Press, 1975

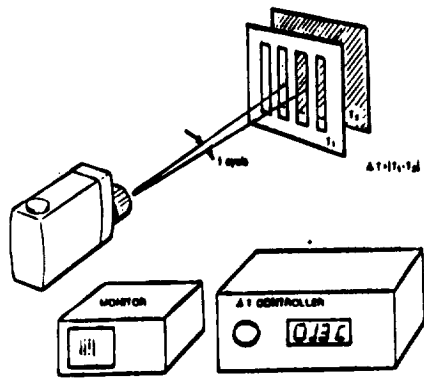

Figure 1. Minimum resolvable temperature difference

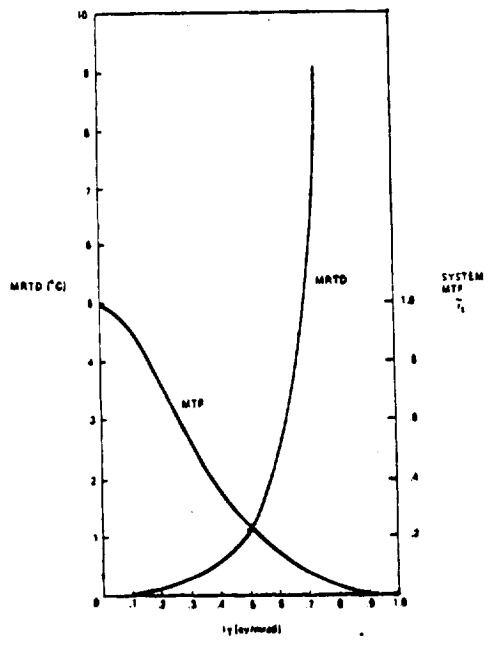
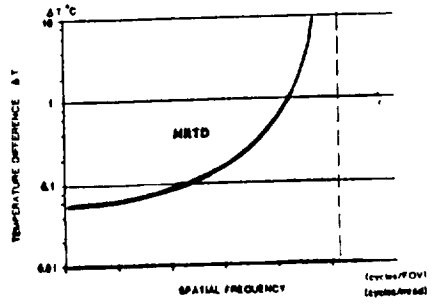
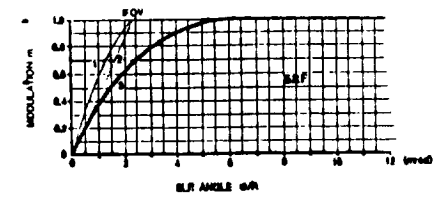
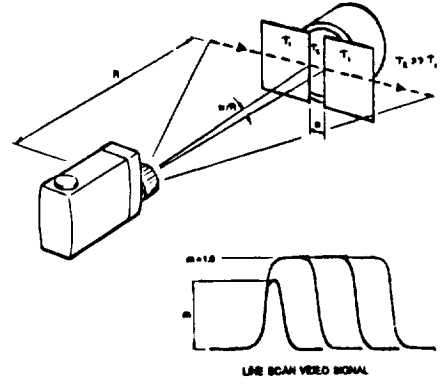

Figure 2. MRTD and MTF for the example system.



- 1) Ideal MTF for circular detector
- 2) Ideal MTF for square detector
- 3) Typical measured MTF

Figure 3. Slit response function