

470  
N90-17964**U.S. ACTIVITY WITH THE OLYMPUS SATELLITE**

Warren L. Stutzman

Satellite Communications Group  
Bradley Department of Electrical Engineering  
Virginia Tech  
Blacksburg, VA 24061Richard Campbell  
Department of Electrical Engineering  
Michigan Tech  
Houghton, MI 49931

Future communication systems will move toward the 20/30 GHz frequency range for wider bandwidth and reduced interference, and will use small earth terminals (VSATs). Previously, communication systems used large earth terminals with wide fade margins to achieve high reliability. Modest reliability requirements coupled with fade compensation techniques (uplink power control, variable rate encoding, dynamic resource sharing, etc.) have made inexpensive, low margin VSAT terminals practical. Past propagation experiments accumulated data for the wide margin system configurations; however, emphasis must now shift to the measurement and modeling of low margin systems. This requires accurate measurement of fade statistics and fade dynamics for low/moderate fading. Fade dynamics now play an important role in the design of compensation schemes.

The European Space Agency satellite OLYMPUS is scheduled for launch this June and will be ready for use in October. OLYMPUS has 12, 20, and 30 GHz beacons (more accurately 12.5, 19.77, and 29.66 GHz). Virginia Tech and Michigan Tech are working with NASA/Jet Propulsion Laboratory on an OLYMPUS experiment and hardware development program. Receiving systems at 12, 20, and 30 GHz will be installed at Virginia Tech.

OLYMPUS beacons provide coverage of the east coast of the United States sufficient for attenuation measurements. The elevation angle to Blacksburg, Virginia, is 14 degrees. A unique feature of the OLYMPUS beacon package is that the three spacecraft beacons are derived from a common oscillator, yielding coherent beacons. The Virginia Tech OLYMPUS receivers are designed to take advantage of this coherence by deriving frequency locking information from the 12 GHz

receiver for all three frequency receivers. This widens the effective dynamic range of the 20 and 30 GHz receivers, which are more susceptible to fading during a rain event. A useful dynamic range of 34 dB is expected from both the 20 and 30 GHz receivers.

Clouds and scintillation can produce up to 3 dB attenuation at 30 GHz on a 14 degree elevation angle path and may be present for a high percentage of the time. It is important in a slant path propagation experiment to be able to set the "clear air reference" level accurately. We are incorporating radiometers at each beacon frequency into our receiving system to aid in setting this clear air reference level. The radiometers are of the total power design; the RF and IF sections are housed in temperature controlled environments to keep gain constant.

The east coast of the United States is far off boresight of the OLYMPUS 20 and 30 GHz antennas. As a result, there will be a loss of antenna gain from the satellite, not exceeding 8 dB at 30 GHz. There is sufficient EIRP from the beacons for good measurements to be made with moderate sized antennas. Cross-polarization measurements are not feasible, however, because the satellite antennas have low XPD well away from boresight.

Figure 1 illustrates the planned hardware for the OLYMPUS experiments. The objectives of the experiment are summarized in Table 1. The receiving antennas are 12, 5, and 4 feet in diameter at 12, 20, and 30 GHz, respectively. Thus, the 20/30 GHz portion of the experiment will employ VSAT class terminals. There is a second 20 GHz receiver identical to the first for the purpose of examining small scale diversity. Although widely spaced diversity terminals have been studied for deep fade cases, short baseline diversity for low/moderate fading has not.

Table 1 summarizes the components of the experiment. Fade measurements are directed toward producing data necessary to assemble information on the following: fade occurrence frequency, fade duration and fade interval statistics, frequency scaling of attenuation, and fade slope data. Small scale diversity will be examined as well.

Figure 2 gives a block diagram level overview of a typical channel and Figure 3 shows one of the four RF front ends. In all cases a common IF frequency of 1120 MHz is used. Receiver hardware and software have been designed to be used directly (or in some cases with modification) with ACTS. The analog receiver includes a digital detection scheme developed at Virginia Tech. It produces a 16-bit digital output directly from a 10 kHz signal for in-phase and quadrature-phase

components, allowing amplitude and phase extraction via software in the Data Acquisition System (DAS). The sample rate is variable between 10 and 100 Hz.

The total power radiometers at 12, 20 and 30 GHz use the same front ends as the main receivers. A 25 MHz band of noise is filtered at the 1120 MHz IF, and detected with a square-law diode. A noise calibrator is included which injects a known level of excess noise into the radiometer front end at regular time intervals. Two point calibration of the radiometers is accomplished using hot and cold loads. The total power radiometer is very sensitive to gain changes in the RF and IF amplifiers, which produce the same changes in the radiometer output as variations in antenna noise temperature. All components in the radiometers will be in temperature controlled environments with better than 1°C temperature stability. MMIC amplifiers will be used in the 1 GHz IF stages. These amplifiers have heavy feedback and show very small gain drift with temperature.

The data acquisition system (DAS) software developed for this project is a menu driven package that permits data collection and preview/display. Propagation data from as many as eight channels will be collected, stored, and displayed in real time. Included in the data analysis system display are status information for system components as well as weather conditions.

**Table 1**  
**Components of the OLYMPUS Experiment**  
**at Virginia Tech**

**Attenuation Measurements**

Attenuation data will be collected from the 12, 20, and 30 GHz OLYMPUS beacons during a one year period for the following uses:

- Fade statistics
- Fade duration
- Fade interval
- Frequency scaling of attenuation
- Support of studies mentioned below

**Radiometric Measurements**

Radiometric data will be collected to assist in setting reference levels to improve low level attenuation measurement accuracies. However, such data may be useful in its own right.

**Fade Slope Measurements**

Statistics on the rate at which individual fades begin and end (in dB per second) will be accumulated and correlated with the physics of propagation.

**Small Scale Diversity**

A moveable 20 GHz terminal will be stationed near the main 20 GHz terminal.

Attenuation data at the diversity station will be compared to that for the main terminal during the same sub-year time interval.

Diversity gain will be examined for each station as a function of baseline distance.

**Uplink Power Control**

Attenuation data on 20 GHz will be used to test various uplink power control algorithms to predict how fading could be relieved if uplink power control is used.

**Meteorological Support**

- Tipping bucket rain gauges
- X-band PPI radar

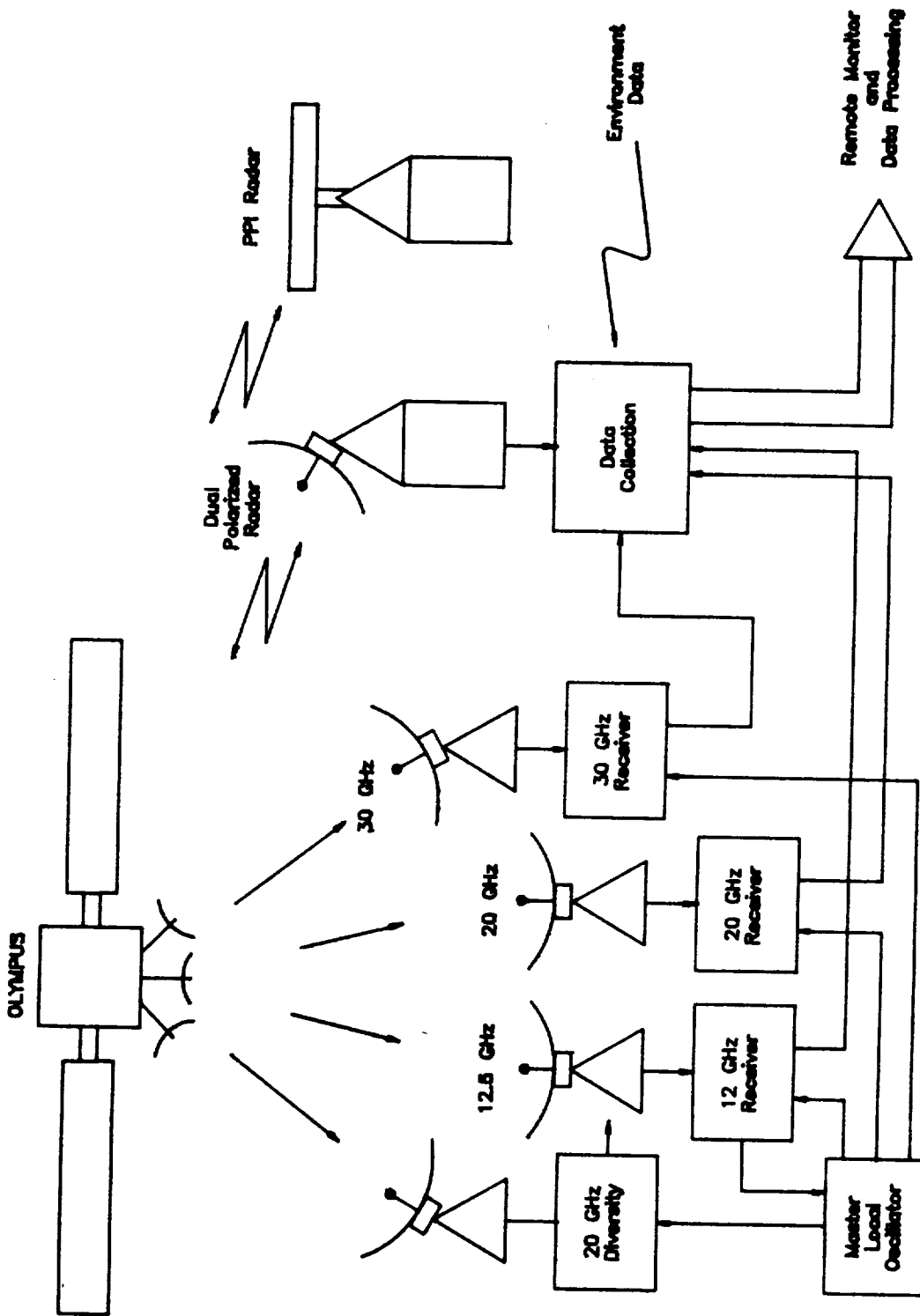

Figure 1. Overview of the proposed OLYMPUS experiment at Virginia Tech.

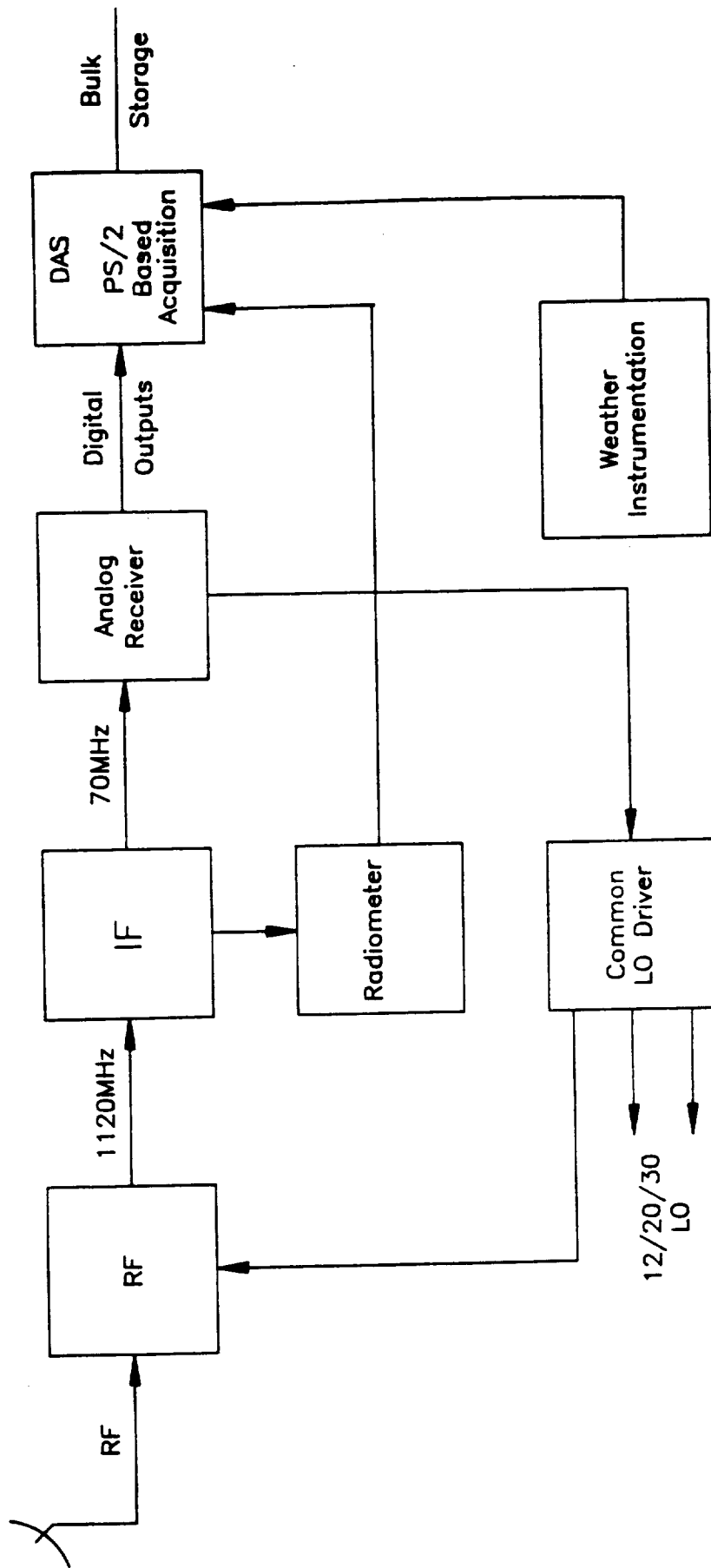
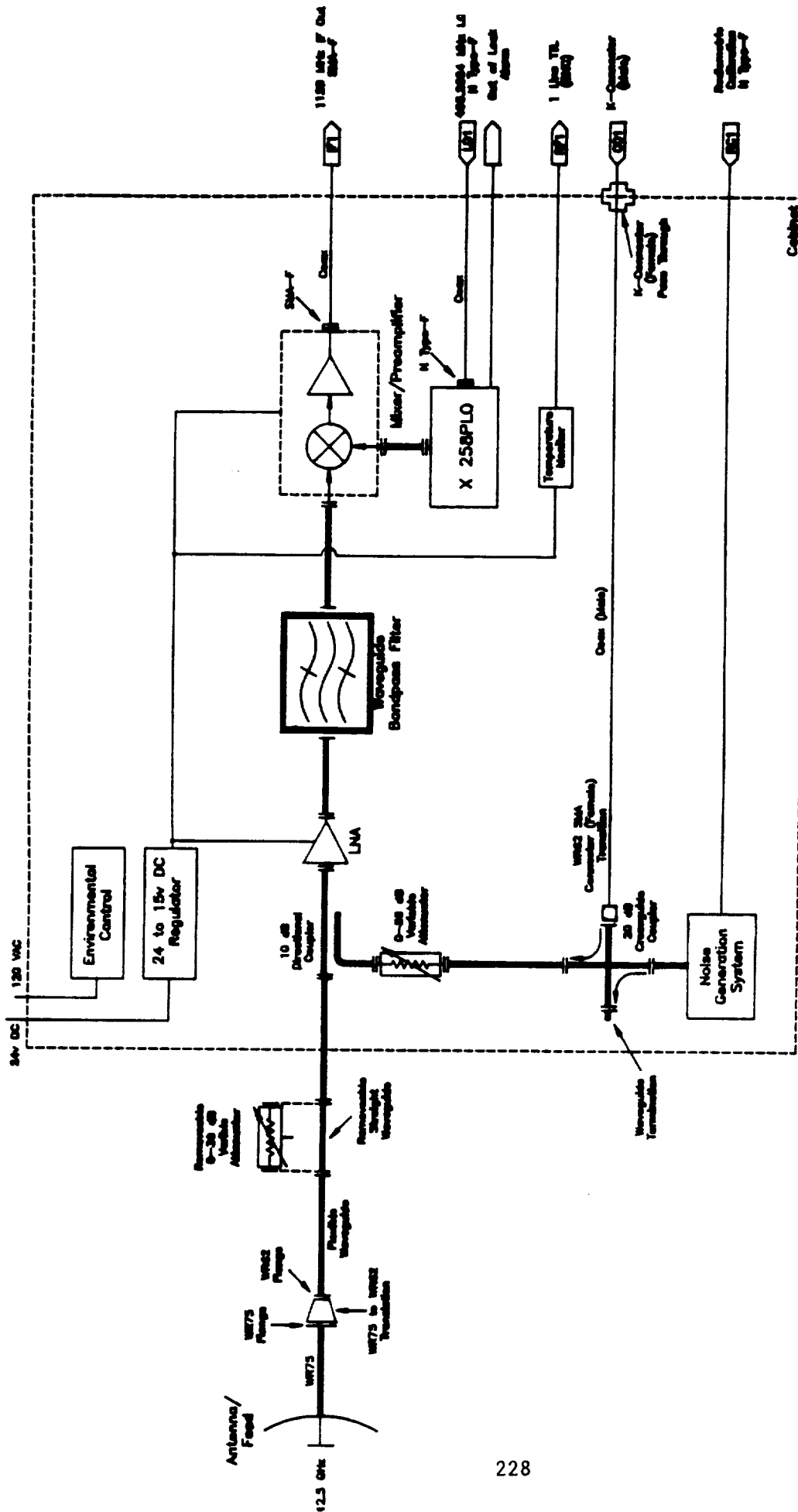

Figure 2. Block diagram of one OLYMPUS receiver.



Waveguide: 10000 MHz LG  
 Unless Specified  
 Pumping: US-110/U

Figure 3. Block diagram of OLYMPUS the 12.5 GHz RF section.

# **PROPAGATION EXPERIMENTS MANAGEMENT PLAN**

John Kiebler  
NASA Headquarters  
Washington, DC 20546



# PROPAGATION EXPERIMENTS PROGRAM (PEP)

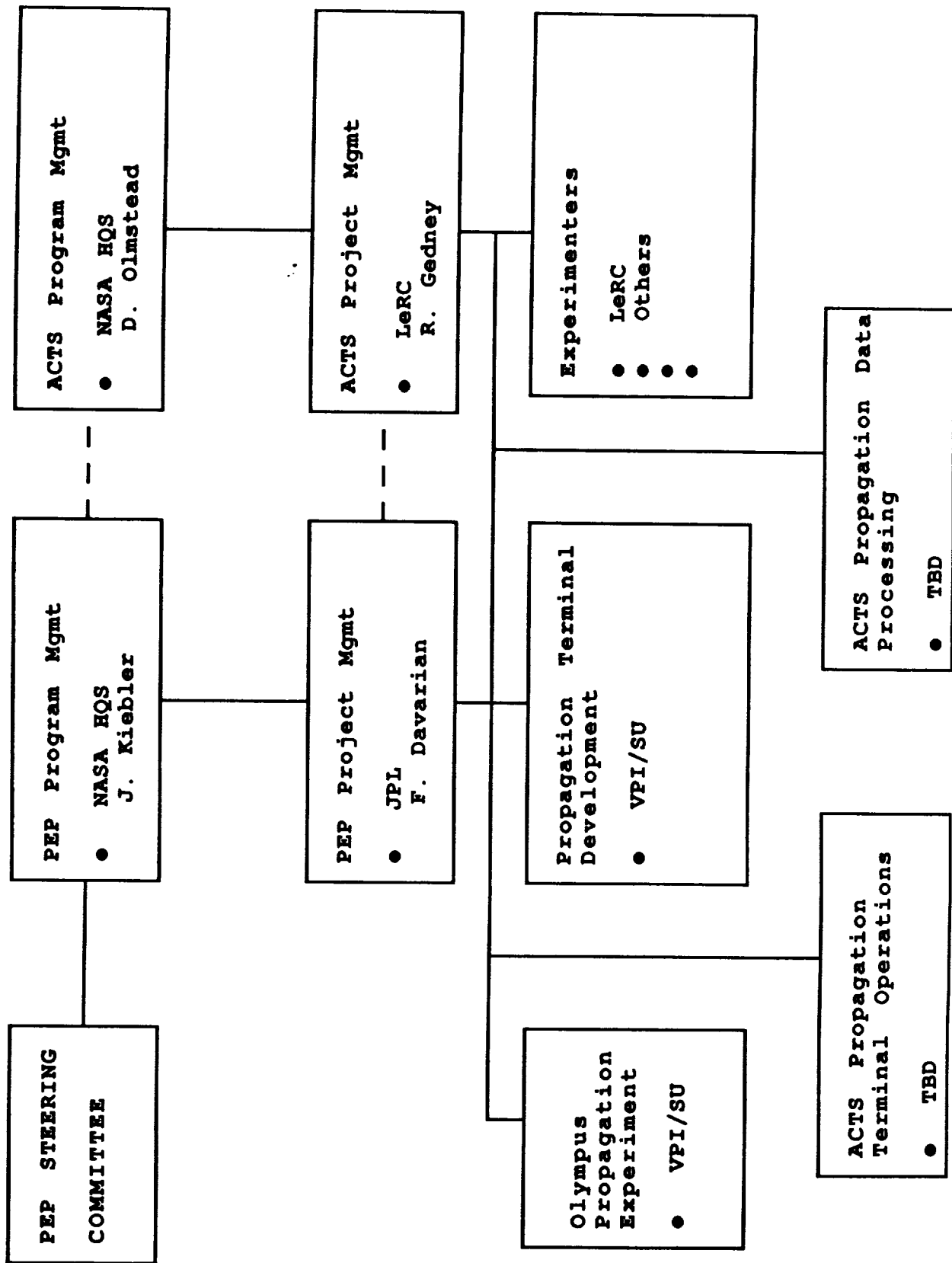

## FUNCTIONS OF ACTS PROPAGATION EXPERIMENTS PROGRAM (PEP) COMMITTEE

- Foster awareness of the opportunity to conduct propagation measurements using ACTS within the government, industry and university communities.
- Critique PEP plans and recommend changes.
- Serve as a liaison between the ACTS Project Office and the propagation community in propagation related matters and issues.
- Advise NASA on propagation related experiments that should be conducted. Act as a catalyst to foster their development within the propagation community.
- Advise NASA on solicitation and selection criteria for propagation experiments.
- Review and coordinate all ACTS propagation experiment.
- Advise NASA on the types of technical information and documentation that is required for proposing, developing and conducting ACTS propagation experiments.
- Provide advocacy for the ACTS experiments program.
- Maintain cognizance of spacecraft development progress and advise on issues germane to propagation experiments program.

WORKSHOP ON ACTS EXPERIMENT PLANNING

AND

MEASUREMENT AND DATA REDUCTION STANDARDIZATION

- OBJECTIVE
- PROVIDE A FORUM FOR DISCUSSIONS RELATED TO PROPAGATION
- DISCUSS AND IDENTIFY ACTS PROPAGATION NEEDS WITH EMPHASIS GIVEN TO SYSTEM ASPECTS
- DISSEMINATE UP-TO-DATE CHARACTERISTICS OF ACTS BEACONS AND SPACECRAFT
- PLAN A COHESIVE SET OF EXPERIMENTS
- INTRODUCE A UNIFORM APPROACH TO DATA COLLECTION AND REDUCTION

## WORKSHOP FORMAT AND AGENDA

- PARTICIPANTS
  - INVESTIGATORS OF THE NASA PROPAGATION PROGRAM
  - REPRESENTATIVES OF THE ACTS PROGRAM OFFICE AND CONTRACTORS
  - EXPERIMENTERS WHO HAVE PREVIOUSLY INDICATED INTEREST IN CONDUCTING ACTS PROPAGATION EXPERIMENTS
  - OTHERS FROM THE PROPAGATION COMMUNITY
- DURATION
  - TWO DAYS
- AGENDA
  - DAY 1:
    - PRESENTATIONS ON ACTS BEACONS AND SPACECRAFT
    - DESCRIPTION OF OLYMPUS EXPERIMENT DESIGN AND STATUS
    - PRESENTATION OF STRAWMAN PLANS FOR ACTS PROPAGATION EXPERIMENTS
  - DAY 2:
    - DISCUSSIONS, CRITIQUE OF STRAWMAN PLANS
    - PREPARATION OF RECOMMENDED EXPERIMENT PROGRAM BY PARTICIPANTS
- PLACE AND TIME
  - JPL OR ENVIRONS
  - LATE 1989

