

Reflector Surface Distortion Analysis
Techniques (Thermal Distortion Analysis
of Antennas in Space)

219964
218.

R. Sharp, M. Liao, J. Giriunas, J. Heighway,
A. Lagin, and R. Steinbach
NASA Lewis Research Center
Cleveland, Ohio

N90-19267

DISTORTED ANTENNA PERFORMANCE ANALYSIS

A group of large computer programs are used to predict the far-field antenna pattern of reflector antennas in the thermal environment of space (Ref 1). TRASYS* is a thermal radiation analyzer that interfaces with SINDA**, a finite difference thermal analysis program. The resulting temperatures must be correlated by SNIP (Ref 2), a new interfacing program. The SNIP+ results become an input file to NASTRAN, a well-known finite-element structural analysis program that results in displacements of the elements of the model. A continuous function is needed for the new physical optics RF analysis. This is provided by a new spline program that creates continuous surface functions from the ungridded data. The RF program results in plots of the far-field RF energy distribution of the antenna.

The entire thermal distortion analysis process is very labor intensive. For large thermal and structural models, individual analysts are usually needed for the TRASYS, SINDA and NASTRAN programs. Interim and final results are interpreted by the full group of analysts.

*Thermal Radiation Analysis System (TRASYS)

**Systems Improved Numerical Differencing Analyzer (SINDA)

+SINDA-NASTRAN Interfacing Program (SNIP)

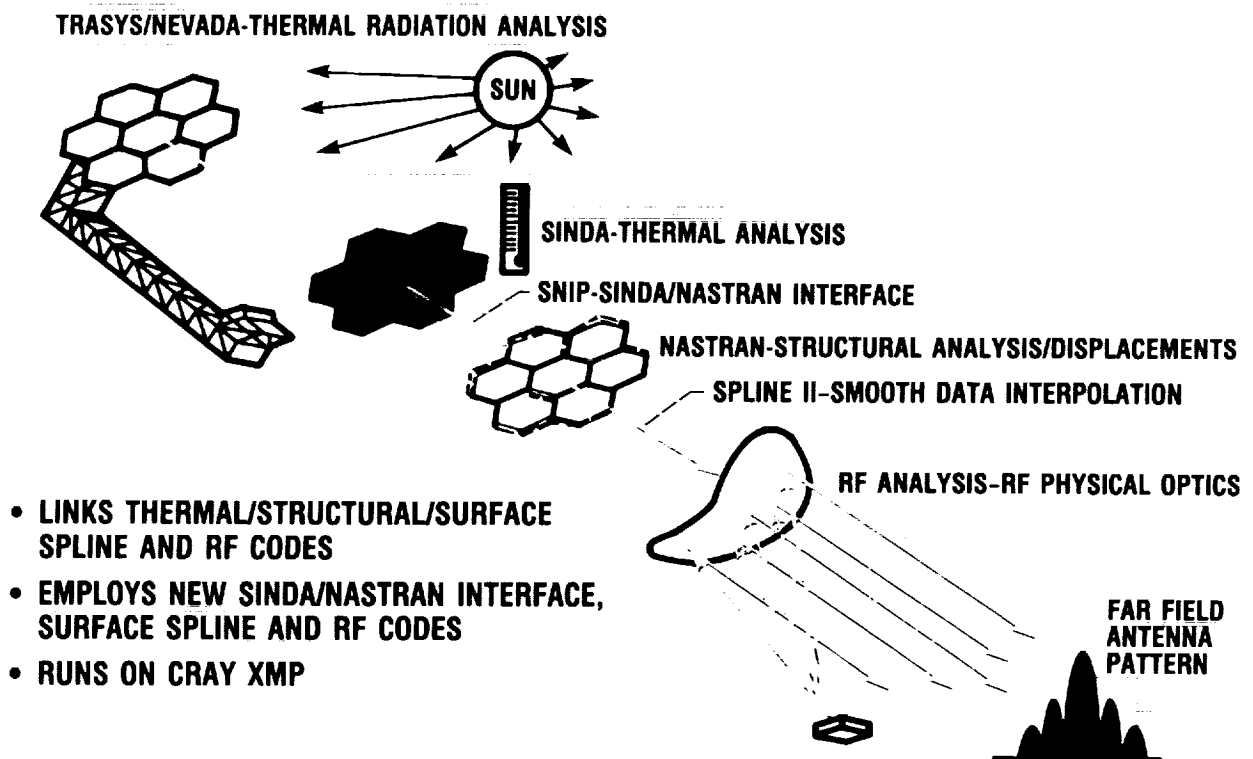

ADVANCED COMMUNICATION TECHNOLOGY SATELLITE

The Advanced Communications Technology Satellite (ACTS) is an experimental NASA satellite scheduled to be flown in geosynchronous orbit in the early 1990s. It employs data communication links at the Ka band using 30 GHz uplinks and 20 GHz downlinks. It was used as the spacecraft thermal model for the antenna reflector thermal distortion analysis because it is a representative geosynchronous spacecraft with all of the shadowing and eclipse solar radiation geometries that typify that class of spacecraft.

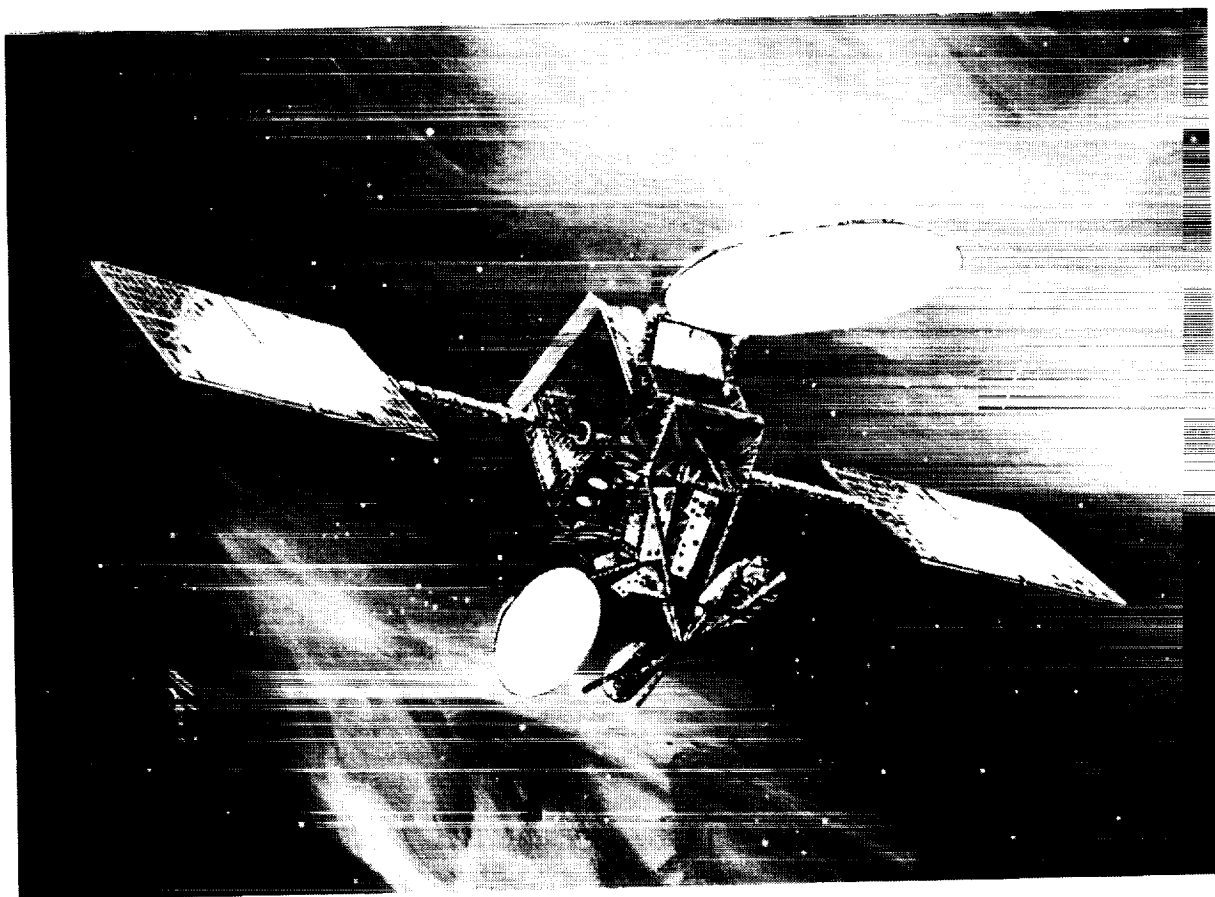

**ORIGINAL PAGE IS
OF POOR QUALITY**

PRECISION FLIGHT REFLECTOR (REINFORCING RIB AND MLI SIDE)

A precision flight reflector of NASA design was substituted for the actual ACTS transmit antenna for this analysis. This was done so that the effects of various geometries and materials on antenna performance could be explored. The design chosen was a space flight version of a high precision ground based experimental antenna reflector. The 3.3 M antenna reflector is a lightweight composite structure comprising reflector face, strongback ribs and multi-layer insulation (MLI). This view is of the reinforcing rib side of the reflector.

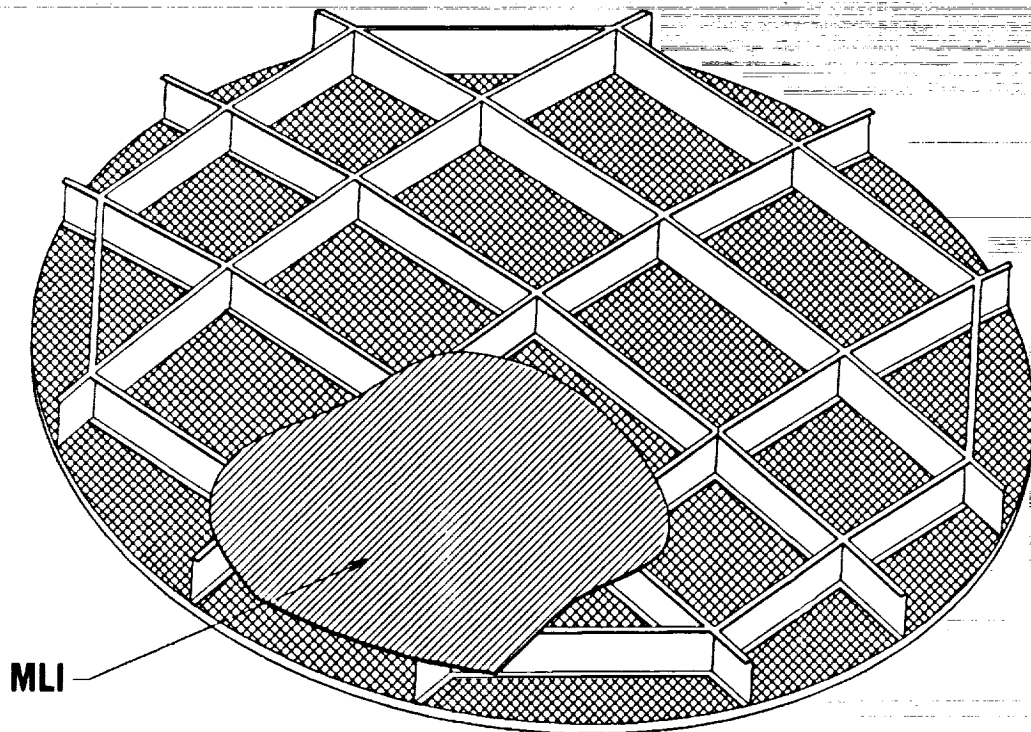

PRECISION FLIGHT REFLECTOR-REFLECTOR SIDE

The reflector side of the Precision Flight Reflector would first be machined and then covered with a surface that would be aluminized by vapor deposition for RF reflectance.

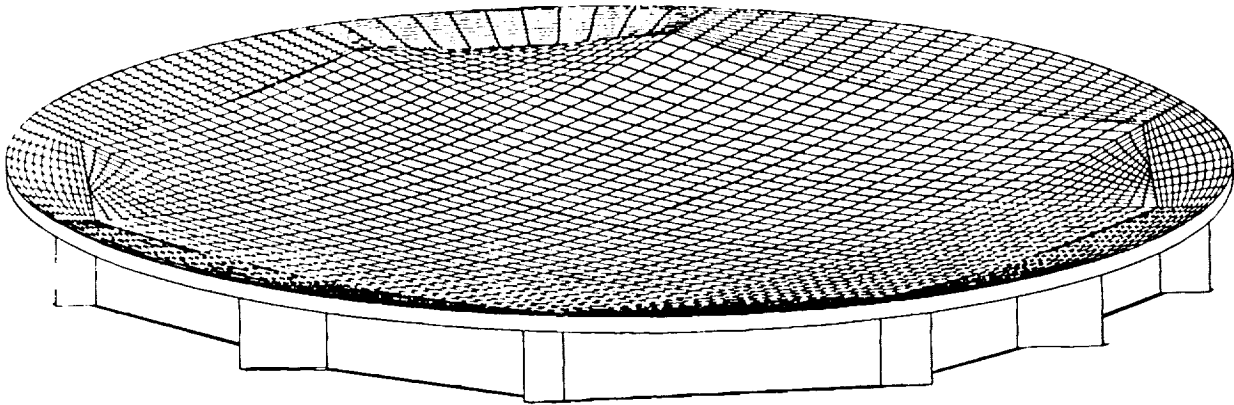

PRECISION FLIGHT REFLECTOR-SECTIONAL VIEW

The cross-sectional view depicts the construction of the 3.3 M antenna reflector. The back of the reflector is covered with a multilayer insulation blanket. The back-up channel is constructed using graphite/epoxy material. The lower channel flange uses unidirection plies while the channel is constructed using cross plied fabric. Flat aluminum core honeycomb sandwich panels with six ply graphite face sheets are used for mounting the Nomex honeycomb core (Hexcel Corp.) that is then machined to the required contour. This machined core material is then covered with a very thin fiberglass-epoxy adhesively bonded face sheet that is finally aluminized by vapor deposition for the reflective surface finish. White paint would then be applied to this surface for thermal control.

The purpose of this type of construction was to fabricate a reflector that was less expensive than others because no molds would be needed and little accuracy would be needed for the back-up structure. It would be resistant to thermal distortion by nature of the construction and basic materials used and yet accurate because the final reflective surface could be applied to a precisely machined surface.

3.3 METER DIAMETER PREDICT SURFACE DEFORMATION DUE TO THERMAL LOADING

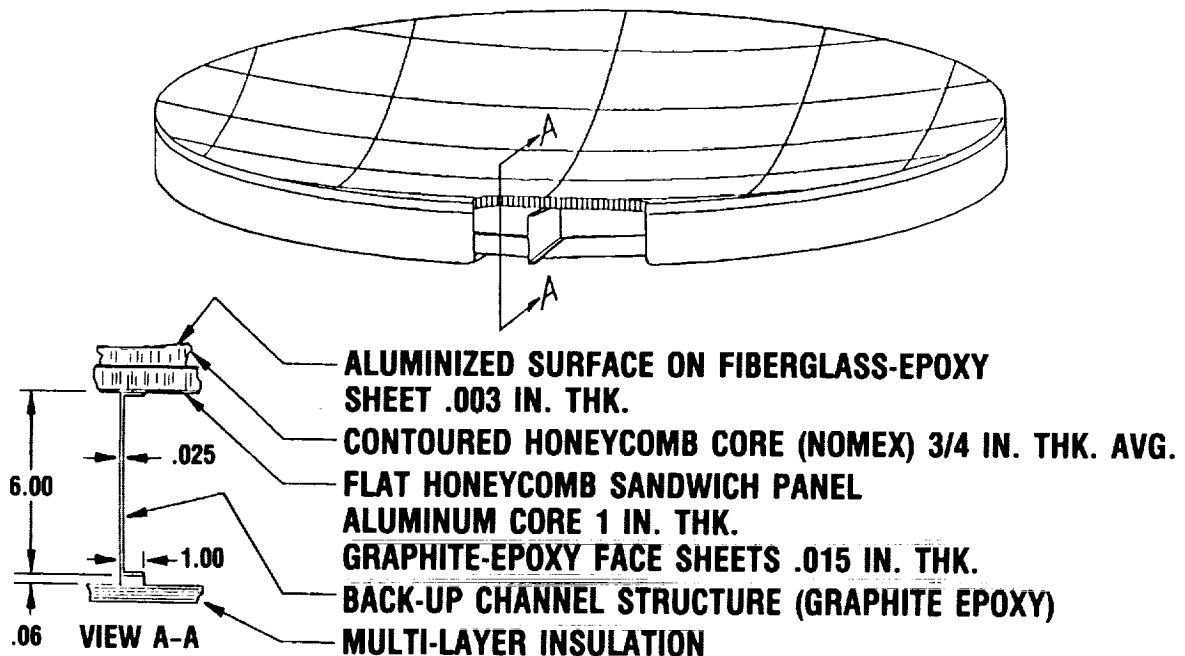

THERMAL RADIATION ANALYSIS SYSTEM

The computer code TRASYS (Thermal Radiation Analysis System) was used to characterize the thermal environment of the spacecraft in a geosynchronous orbit. The model geometry, surface properties, orbit and spacecraft orientation must be defined. Then TRASYS takes into account radiation from direct solar, planet albedo, planet infrared, specular and diffuse reflections of both solar and IR wavebands, transmissivity of surfaces and spacecraft self-shadowing. TRASYS then generates the radiant heat interchange factors and the radiant heat inputs to each element of the model and these become the input to the SINDA thermal analyzer.

Our TRASYS model consists of approximately 350 elements. The 20 GHz 3.3 M diameter antenna main reflector was modeled with relatively small triangular elements. The remainder of the spacecraft structure was modeled with much less detail since it is only of interest in how it shadows the antenna main reflector.

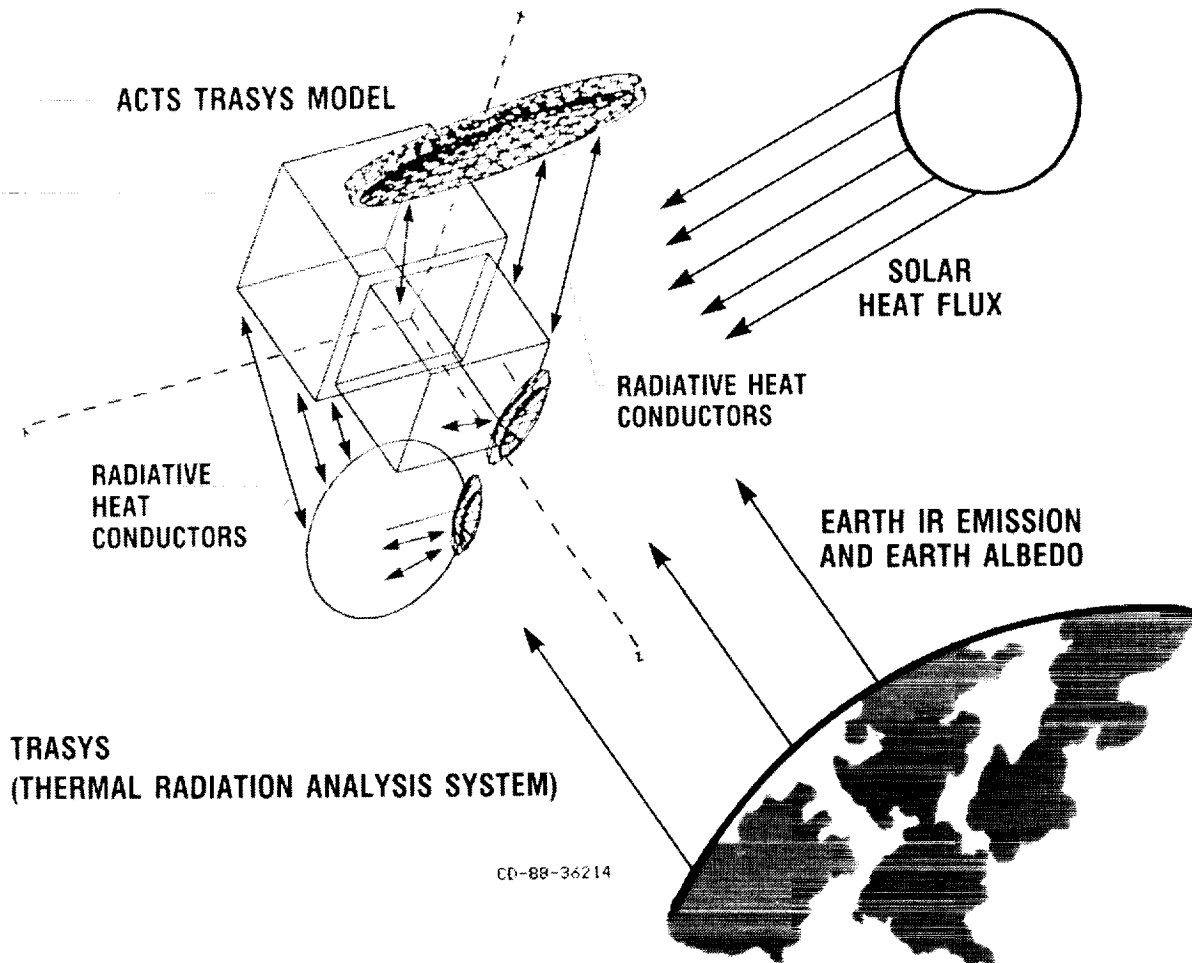

SYSTEMS IMPROVED NUMERICAL DIFFERENCING ANALYZER

SINDA (Systems Improved Numerical Differencing Analyzer) is a lumped capacitance, finite difference thermal analyzer. Each node in the SINDA model may be thought of as a point having thermal capacitance. All nodes are connected to other nodes by linear (i.e. thermal conductance) and non-linear (i.e., radiation heat transfer) conductances.

The figures illustrate the 3.3 M diameter reflector SINDA model and its resistance-capacitance (R-C) network. The antenna reflector consists of two honeycomb sandwich layers, a stiff strongback rib structure and multi-layer insulation (MLI) covering the back of the reflector. A total of eight layers of SINDA nodes were used through the depth to model the three face sheets, two honeycomb core layers, rib, rib tip and MLI respectively. This large SINDA model comprises 849 thermal nodes and 6561 conductors. Among these, 2028 are linear conductors and 4533 are radiative conductors.

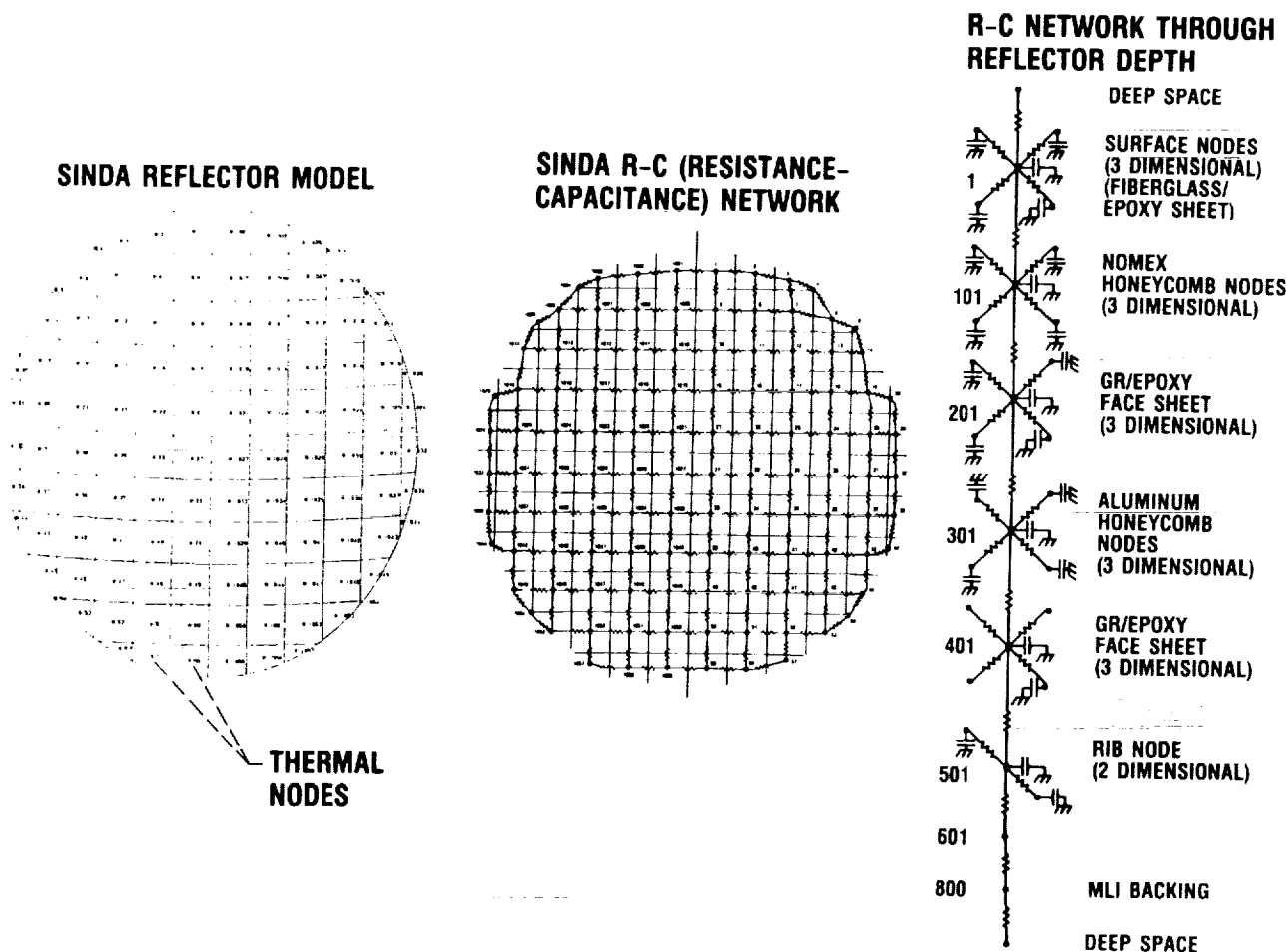

SINDA-NASTRAN INTERFACING PROGRAM

Predicting thermal distortions and thermal stresses in structures requires the generation of both thermal and structural models of the structure under consideration. Standard practice often entails generation of finite difference thermal models, using a program such as SINDA, to predict temperatures in the structure, and generation of finite element structural models, using programs such as MSC/NASTRAN to predict thermal deformations and stresses in the structure. Correlation of information generated by the SINDA program into the NASTRAN format without the use of an interfacing computer program would be a very long and labor intensive process.

The SINDA-NASTRAN Interfacing Program (SNIP) is a FORTRAN computer code that generates NASTRAN structural model thermal load cards when given SINDA (or similar thermal model) temperature results and thermal model geometric data. SNIP generates thermal load cards for NASTRAN plate, shell, bar, and beam elements.

SNIP uses a geometric search routine and a numerical coding scheme to relate the less dense thermal model nodes to the more numerous structural model elements. SNIP then calculates element temperatures based on the weighted average of temperatures of the thermal nodes related to each element. User controlled input parameters provide control over node-to-element correlation.

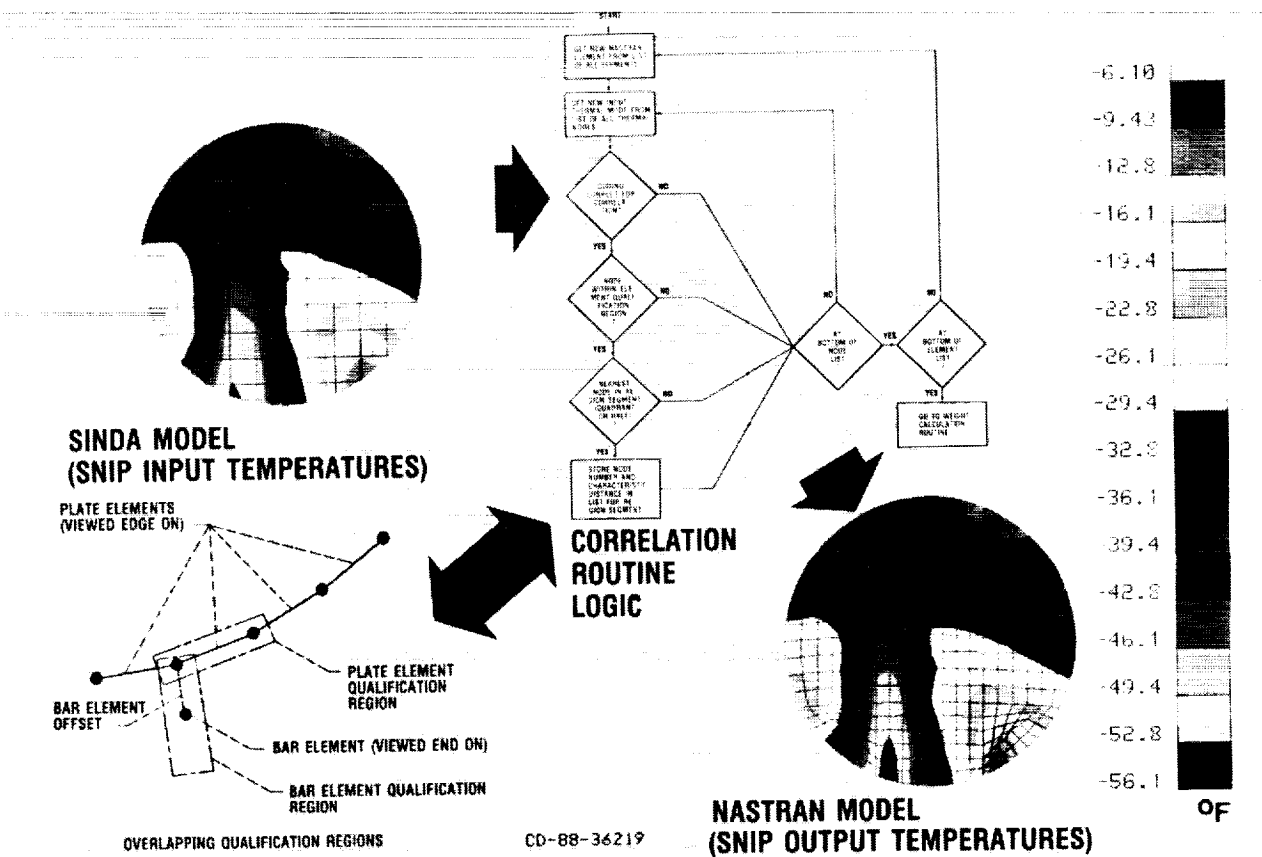

MSC/NASTRAN
(MACNEAL-SCHWENDLER CORP/NASA STRUCTURAL ANALYSIS)

MSC/NASTRAN (Nasa STRuctural Analysis) was used to analyze the 3.3 M diameter antenna reflector to predict its thermal deformation in the space environment. MSC/NASTRAN is a proprietary finite element structural analysis program of the MacNeal-Schwendler Corporation which is used widely in the aerospace industry, providing both static and dynamic analysis capabilities.

The antenna reflector model was constructed using NASTRAN plate and beam type elements which display bending behavior caused by temperature gradients through the element thickness. CADAM (Computer Aided Design and Manufacturing, CADAM Inc.) was used to actually construct the model while PATRAN (PDA Engineering Inc.) was used to display the temperature and displacement data.

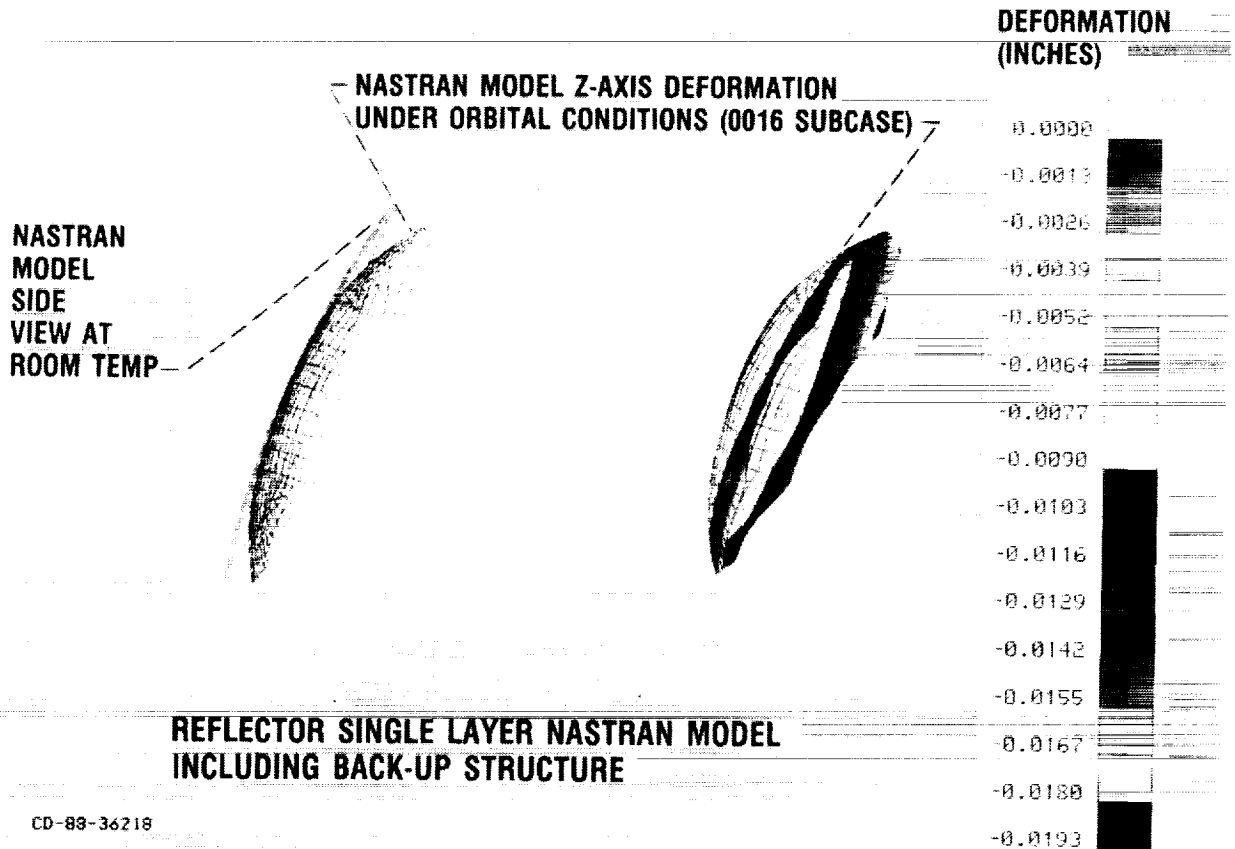

ORIGINAL PAGE IS
OF POOR QUALITY

A COMPUTER PROGRAM FOR THE INTERPOLATION
OF UNGRIDDED DATA

This is a method of bi-variate interpolation for fitting a continuous function with continuous first partial derivatives (a C^1 function), $Z(X,Y)$, through given points (X_j, Y_j, Z_j) whose projections onto the base plane do not conform to any regular grid.

A new interpolation method was needed because other spline programs used higher order polynomials for interpolation and this resulted in high order ripples in the resulting surface of a distorted antenna reflector. These ripples in turn resulted in errors principally in the far sidelobes of the far-field antenna pattern. The purpose of this new interpolation method was to represent the surface with a lower order polynomial that was free of these high order ripples.

Operationally, the program first triangulates the grid points. Next, these triangles are each divided into three sub-triangles. Each sub-triangle is represented by a double cubic function. Slope is then matched along all boundaries of the sub-triangles including the tangent flats. This results in the deformed surface being represented by local double cubic functions that match value and surface normal across all edges.

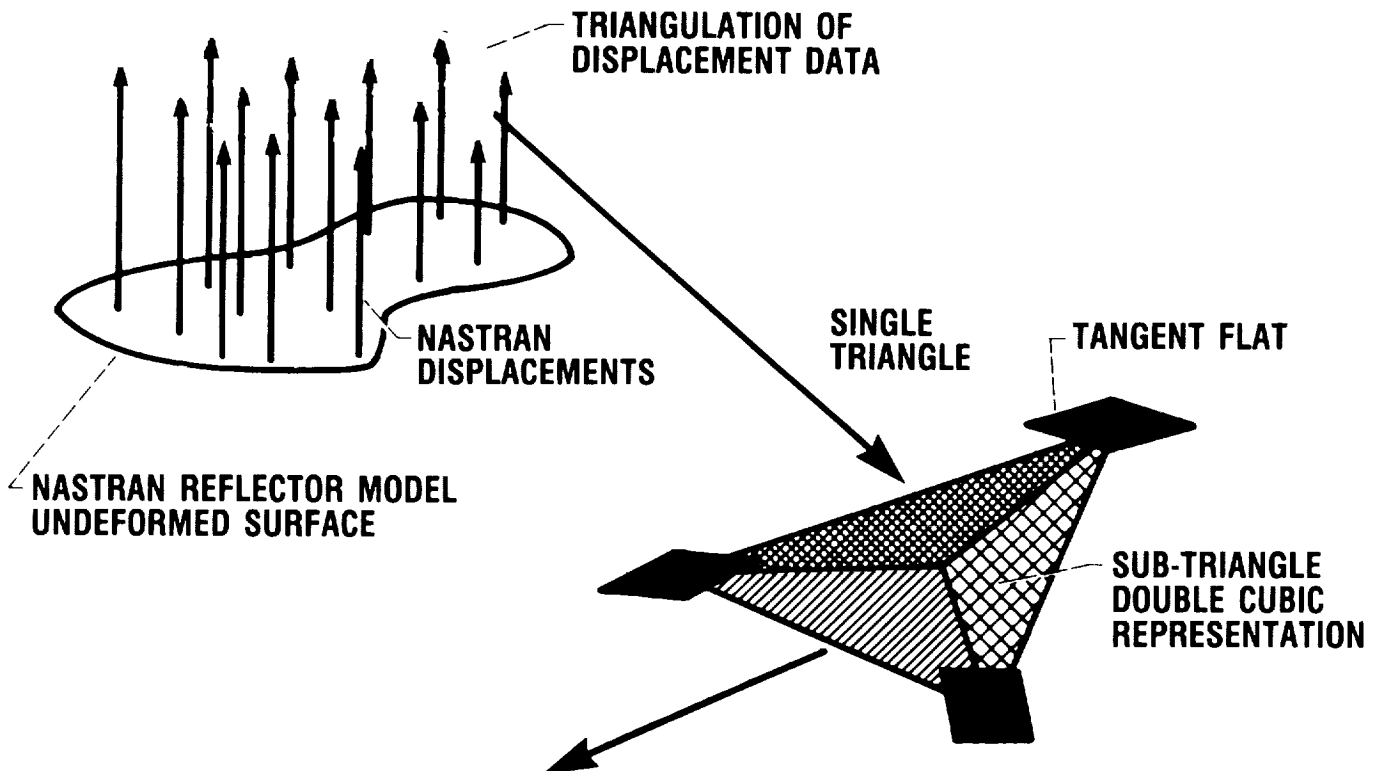

RESULT: DEFORMED SURFACE REPRESENTED BY LOCAL DOUBLE CUBIC FUNCTIONS THAT MATCH VALUE AND SURFACE NORMAL ACROSS ALL EDGES

PHYSICAL OPTICS - DUAL REFLECTOR ANALYSIS RF PROGRAM

The RF program calculates the far-field antenna pattern resulting from a given Cassegrainian reflector configuration profile. It generates two-dimensional graphs of dB directivity versus polar angle for azimuthal angles and produces a table of parameters characterizing beam shape.

This is accomplished by first calculating the current density on the sub-reflector induced by the feed. Next, the current density on the main reflector induced by the sub-reflector is calculated. Finally, the far-field directivity distribution across the polar and azimuthal angles is calculated.

The advantages of this program are that it addresses the more sophisticated Cassegrainian configuration; the modular implementation allows for future configuration flexibility and it utilizes the current distribution method of analysis. This method makes possible the straightforward analysis of the secondary effects of the reflector back on to the sources. Intermediate calculations are also available for auxiliary causal analysis.

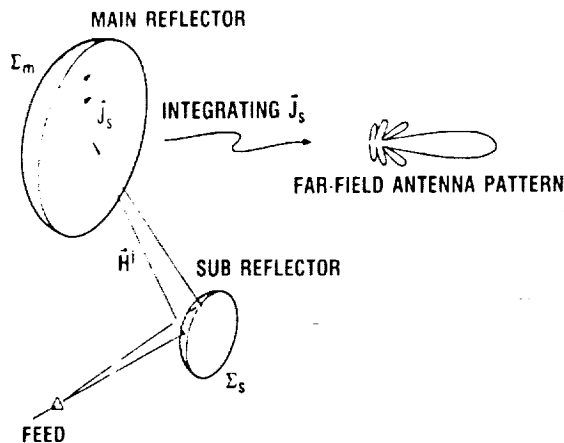

ORIGINAL PAGE IS
OF POOR QUALITY

- **OBJECTIVE—TO CALCULATE THE FAR FIELD DIRECTIVITY PATTERN RESULTING FROM A GIVEN CASSEGRAIN REFLECTOR CONFIGURATION PROFILE.**
- **APPROACH—PHYSICAL OPTICS.**
- **FEATURES**
 - **ADDRESSES THE MORE SOPHISTICATED CASSEGRAIN CONFIGURATION.**
 - **MODULAR IMPLEMENTATION ALLOWS FOR FUTURE CONFIGURATION FLEXIBILITY.**
 - **UTILIZES THE CURRENT DISTRIBUTION METHOD OF ANALYSIS WHICH:**
 - **MAKES POSSIBLE THE STRAIGHT-FORWARD ANALYSIS OF SECONDARY EFFECTS OF THE REFLECTOR BACK ONTO THE SOURCES.**
 - **INTERMEDIATE CALCULATIONS ARE AVAILABLE FOR AUXILIARY CAUSAL ANALYSIS.**

DAILY TEMPERATURE CONTOUR PLOTS (TWO-HOUR PERIOD)

The temperature contour plots for the geosynchronous orbit on April 15 with sun declination at $+9^\circ$ are shown below: The sub-reflector and spacecraft body cast the maximum shadow on the reflector at this sun declination. The numbers on the upper left corner of each plot indicate the time of day for the satellite. The time of day for the satellite is arbitrary. In our case, 0 hour was defined when the satellite lay on a direct line between the sun and the earth.

At the 0th hour, the reflector is facing the earth and deep space with the sun illuminating the MLI. By the ninth hour, the main antenna reflector is starting to catch the sun. At the 13th hour, the entire main antenna reflector is facing the sun and this is the hottest case of the day with temperatures of up to $+16^\circ\text{F}$. The spacecraft shadows the main antenna reflector between the 13 and 18 hours. After the 19th hour, the antenna reflector is pointing away from the sun and facing deep space again. The coldest case of the day occurs at the 24th hour when the reflector is fully facing deep space with temperatures down to -140°F .

April 15 (Sun Declination $+9^\circ$)

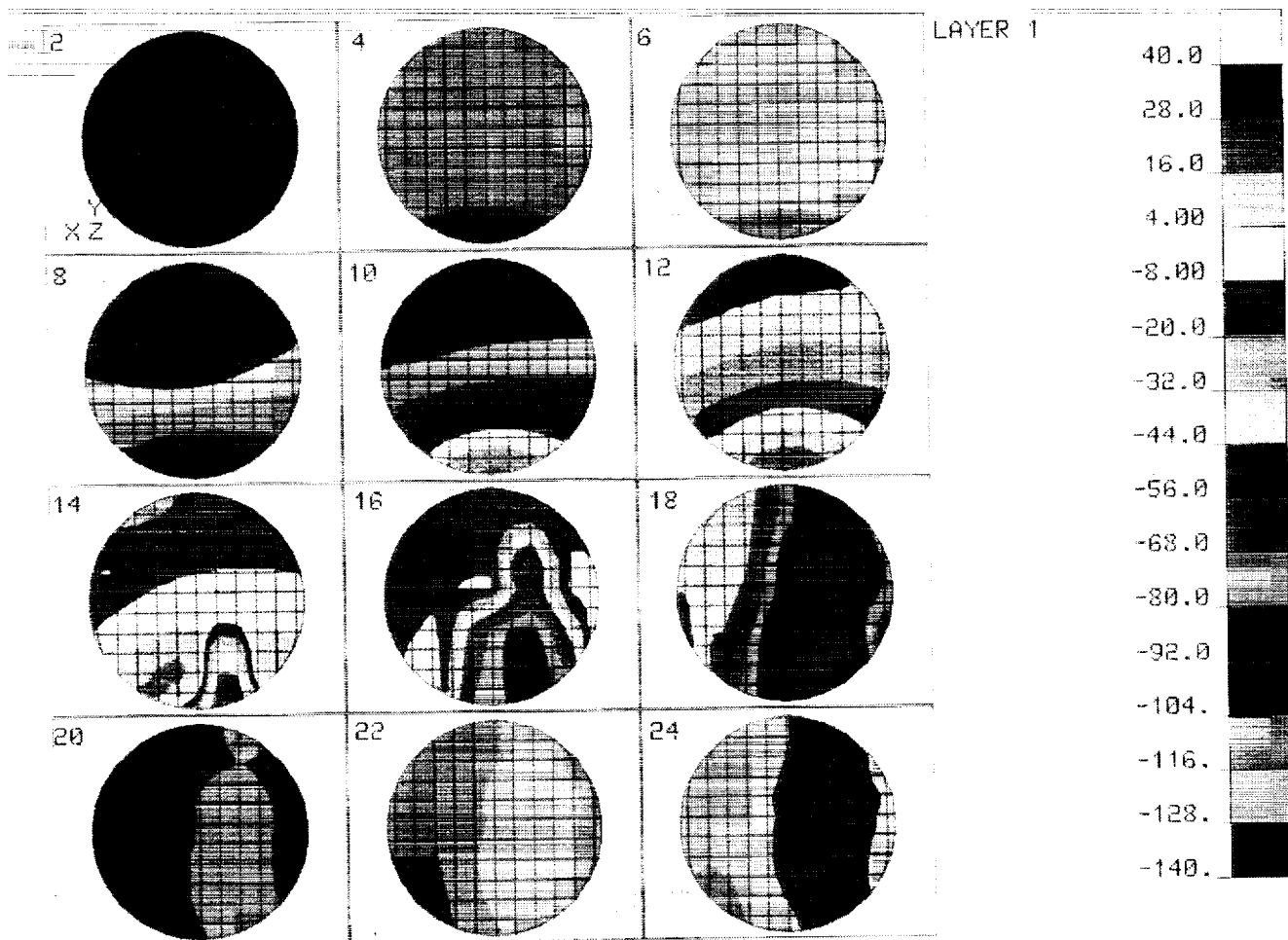

DAILY TEMPERATURE CONTOUR PLOTS (ONE-HALF HOUR PERIOD)

In order to visualize the effects of spacecraft shadowing on the 3.3 meter main antenna reflector in more detail and determine the time of the day for maximum reflector temperature gradient, reflector temperature contours were plotted at $\frac{1}{2}$ hour increments.

Maximum Temperature Gradient Reflector Temperatures at One-Half Hour Increments for April 15 (Sun Declination +9)

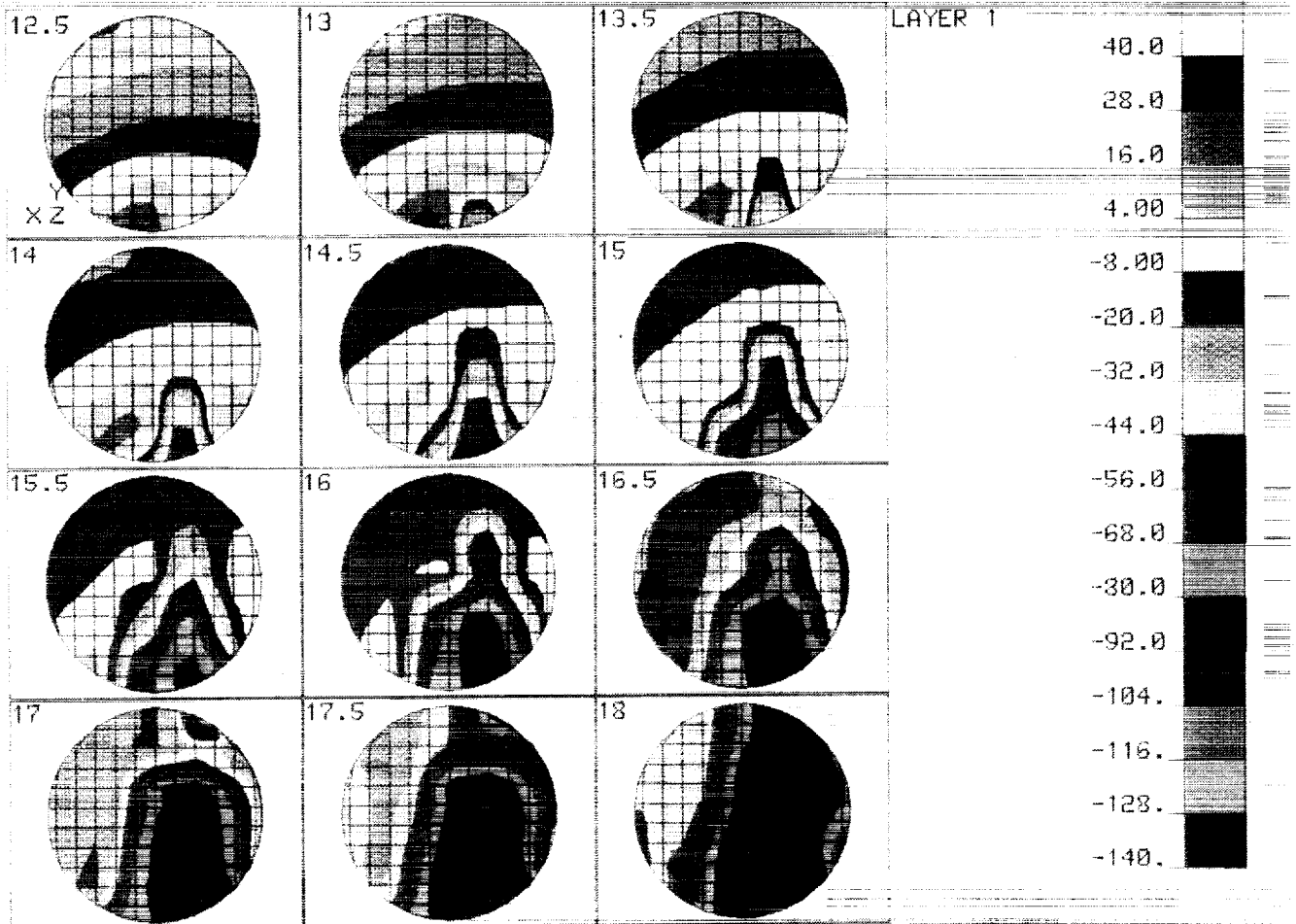

**ORIGINAL PAGE IS
OF POOR QUALITY**

ACTS SPACECRAFT ATTITUDE FOR MAXIMUM REFLECTOR TEMPERATURE GRADIENT

The ACTS Spacecraft is shown here at a solar declination of +9 degrees. At the sixteenth hour of orbit time, the large main antenna reflector shown on the viewer's right is rotating away from the viewer, who is in the position of the sun. At this sixteenth hour, one can see that the large main reflector is rapidly becoming shadowed by the sub-reflector and the spacecraft body, thus producing the maximum temperature gradient across the reflector surface.

Orbit Time (Hours) = 16
Solar Declination (Deg) = 9
Anomaly (Deg) = 60
Eclipse Duration (Min) = 0.0

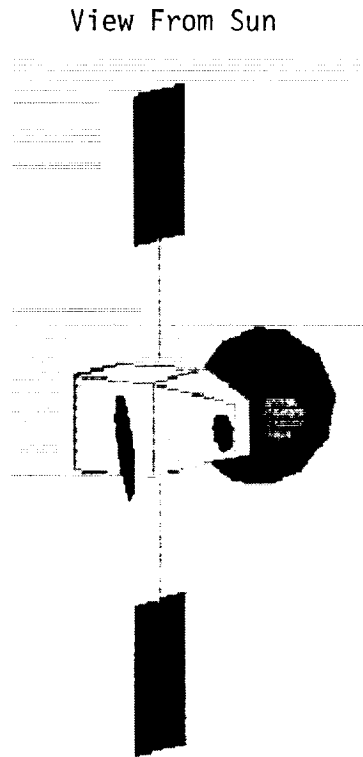

**ORIGINAL PAGE IS
OF POOR QUALITY**

HOT, COLD AND MAXIMUM TEMPERATURE GRADIENT REFLECTOR TEMPERATURES

The two previous reflector temperature contour plots are for two-hour increments and one-half hour increments respectively for the specific date of April 15 which corresponds to a solar declination of +9 degrees. From these plots for this specific day, the hottest temperatures of -44°F to +28°F occur at the orbit time of 13 hours; the coldest case is at 24 hours when the temperature varies from -140°F to -116°F and the maximum temperature gradient of 72°F across the center of the reflector occurs at approximately 16 hours. All these times are approximate since the temperatures must be examined in continuously finer time increments to obtain the exact times. It should also be understood that hotter and colder cases than shown here occur at other times of the orbit year. The April 15 date was picked because near maximum shadowing occurs at this time.

April 15 (Sun Declination +9)

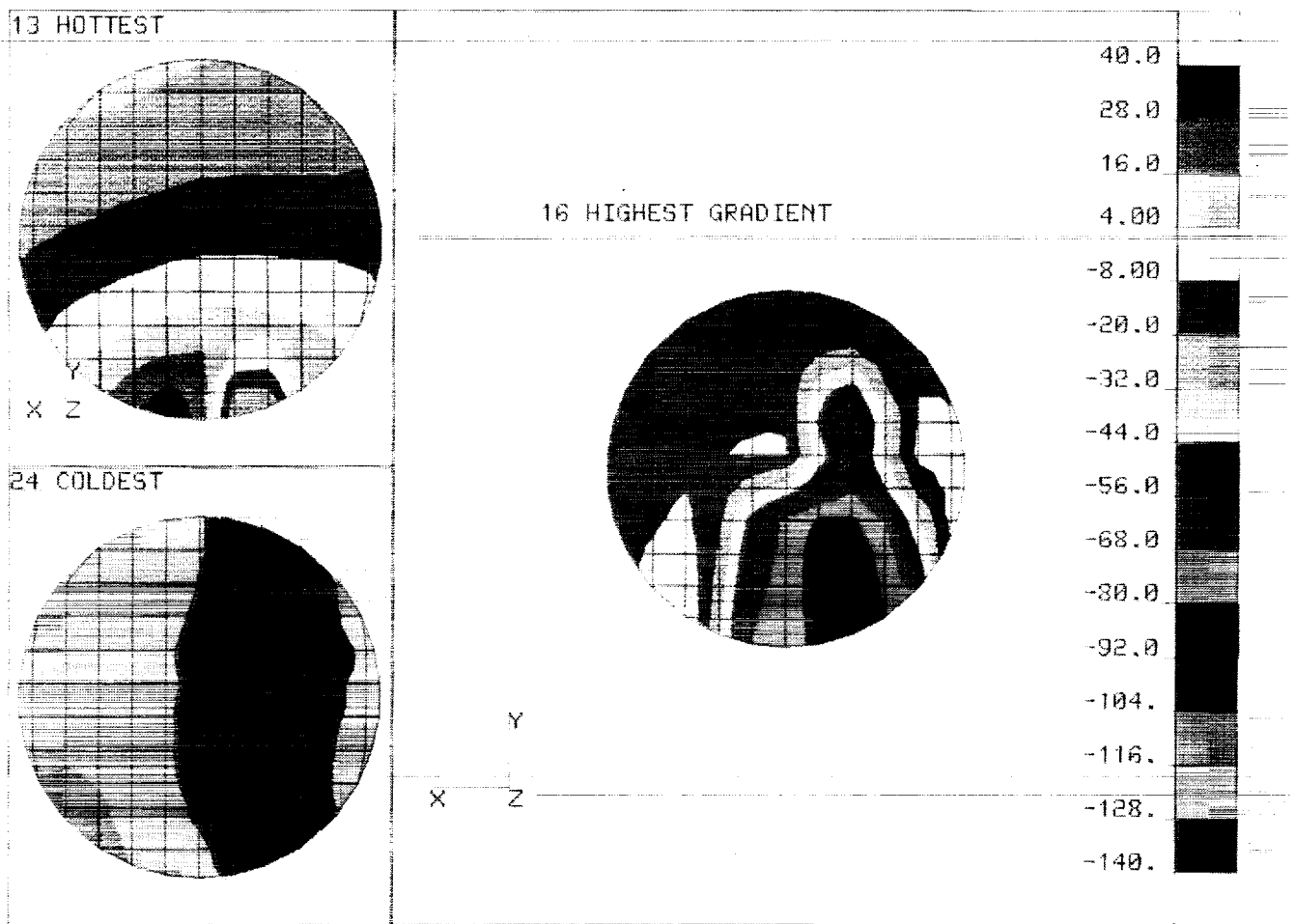

HOT, COLD AND MAXIMUM TEMPERATURE GRADIENT REFLECTOR DEFLECTIONS

The reflector deflections in the Z axis are shown for the hottest, coldest and maximum reflector temperature gradient cases of the previous figure. The displacements are plotted on the NASTRAN finite-element grid. The plots were created using PATRAN. Note that the finite-element grid is much finer than the grid used for the SINDA model shown on the previous chart. This occurs because SINDA does not allow models as large as NASTRAN and also much of the SINDA input must be hand calculated.

All deflections shown are in the minus Z direction. Thus, the reflector has a concave deflection superimposed on the parabola of revolution for all cases. For the hottest case, and concave deflections are fairly uniform varying from $-.030$ inches to $-.021$ inches at the reflector outside perimeter with the reflector center at 0.0 inches deflection. For the coldest case, the concavity becomes more exaggerated varying from $-.030$ inches to $-.045$ inches. For the maximum temperature gradient case, a saddle shape is superimposed on the basic concave shape with edge deflections varying from $-.012$ inches to $-.021$ inches.

April 15 (Sun Declination +9)

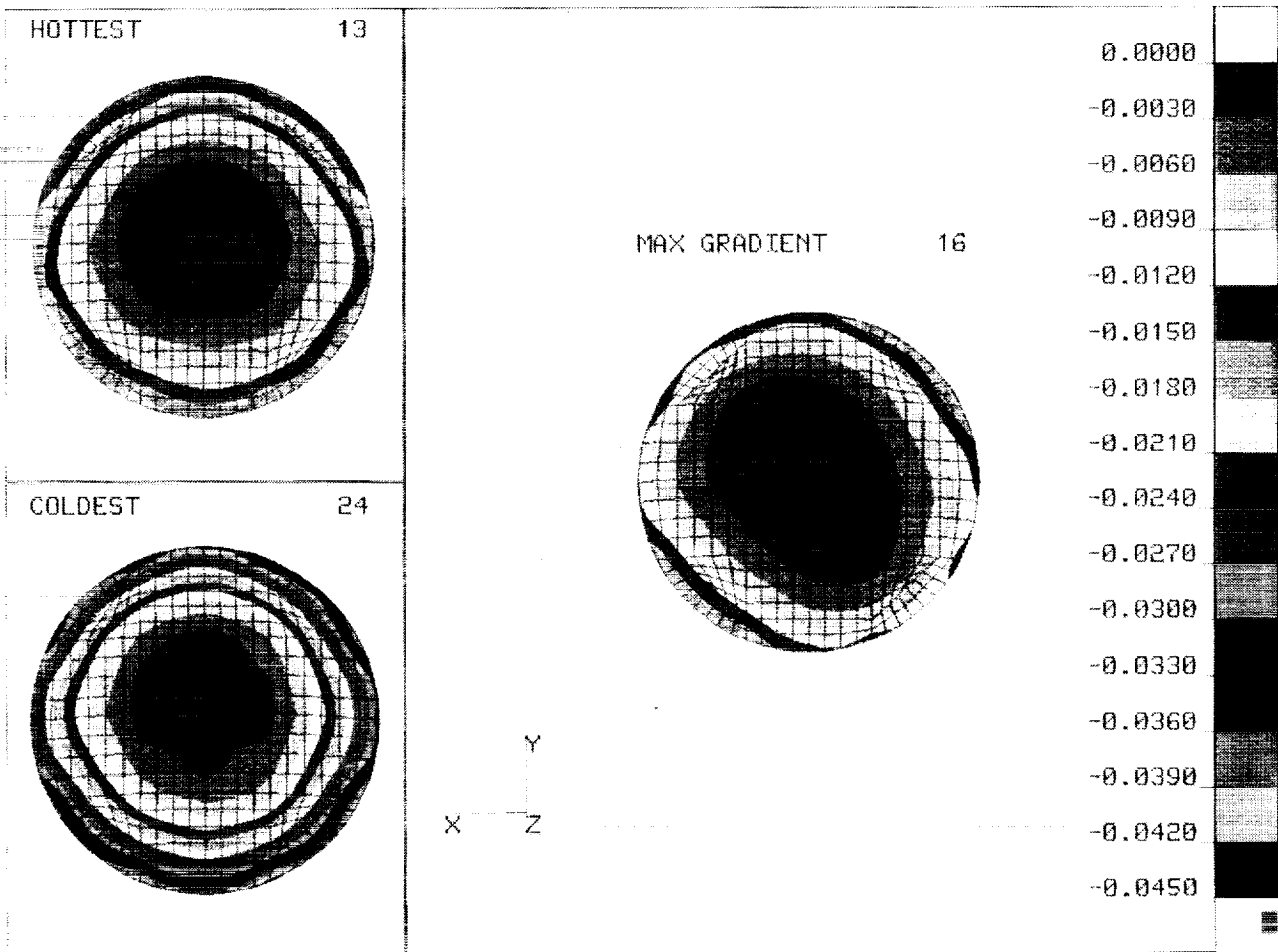

ORIGINAL PAGE IS
OF POOR QUALITY

RF PATTERNS RESULTING FROM THE HOT, COLD AND MAXIMUM TEMPERATURE GRADIENT CASES

The RF patterns shown are for the reflector deflections for the hot, cold and maximum temperature gradient cases shown on the previous page. For this RF analysis, a feed horn with a 17 dB taper was assumed. The dotted line plots are for perfect optics for comparison purposes.

At the time of publication, the new spline and RF programs were not fully operational. These plots were produced using presently available spline and RF programs. The results are correct for the perfect optics cases. However, for the distorted antenna reflector cases, small errors occur in the far sidelobes that are caused by high spacial frequency ripples in the surface calculated by the earlier spline program. These should be corrected when the new spline program becomes operational.

The results calculated using the earlier Geometric Optics single reflector RF program should be the same as for the new multiple reflection RF Physical Optics program. The reason is that the ACTS dual-reflector antenna was modeled as a direct fed single reflective surface for purposes of this simplified analysis.

RF PATTERNS RESULTING FROM THE
HOT, COLD AND MAXIMUM TEMPERATURE GRADIENT CASES

APRIL 15 (SUN DECLINATION +9)

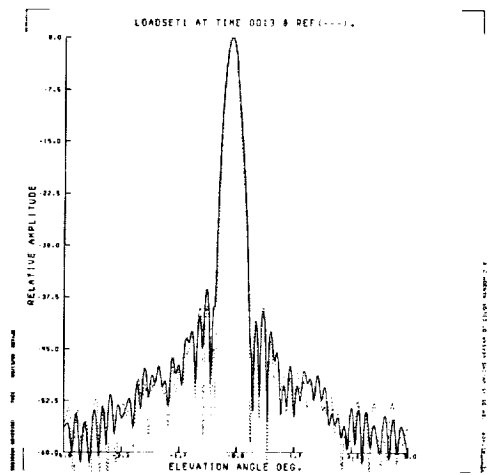

HOTTEST

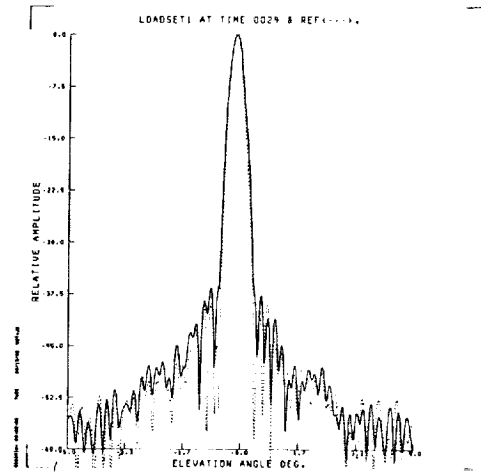

COLDEST

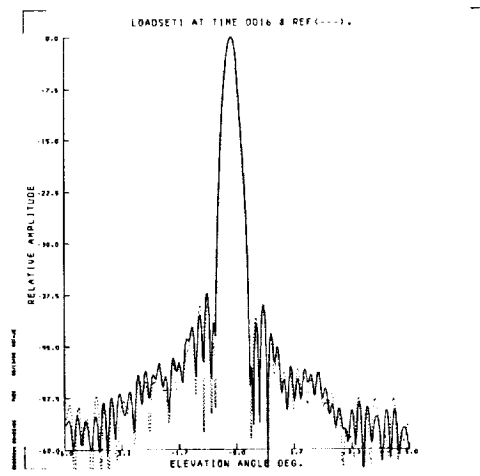

MAXIMUM GRADIENT

**ORIGINAL PAGE IS
OF POOR QUALITY**

CONCLUSIONS

The programs linked together for this analysis can now be used to predict antenna performance in the constantly changing space environment. They can be used for very complex spacecraft and antenna geometries. Performance degradation caused by methods of antenna reflector construction and materials selection are also taken into consideration. However, the principal advantage of using this program linkage is to account for distortions caused by the thermal environment of space and the hygroscopic effects of the dry-out of graphite/epoxy materials after the antenna is placed into orbit.

The results of this type of analysis could ultimately be used to predict antenna reflector shape versus orbital position. A phased array antenna distortion compensation system could then use this data to make RF phase front corrections (Ref 3). That is, the phase front could be adjusted to account for the distortions in the antenna feed and reflector geometry for a particular orbital position.

However, before this can be done, the analysis system would need to be experimentally verified. Also, an amplitude measurement system would probably be needed to measure displacements of key antenna dimensions in space in order to calibrate the whole analytical model. This could be accomplished by a new combined analytical and experimental program

- PROGRAMS CAN BE USED TO PREDICT ANTENNA SYSTEM RF PERFORMANCE IN SPACE
 - ACCOUNT FOR PERFORMANCE DEGRADATION CAUSED BY:
 - METHODS OF CONSTRUCTION AND MATERIAL SELECTION
 - THERMAL AND HYGROSCOPIC DISTORTIONS
- SHOULD BE POSSIBLE TO USE PROGRAM TO PREDICT ANTENNA REFLECTOR SHAPE vs ORBITAL POSITION FOR USE WITH COMPENSATION SYSTEMS. HOWEVER, NEED:
 - PROGRAM ACCURACY VERIFICATION TEST TO VERIFY DISTORTION ANTENNA SHAPES (THERMAL MODES)
 - AMPLITUDE MEASUREMENT SYSTEM TO MEASURE DISPLACEMENTS OF KEY ANTENNA DIMENSIONS IN SPACE

REFERENCES

1. Steinback, R. E.; and Winegar, S. R.: Interdisciplinary Design Analysis of a Precision Spacecraft Antenna. 26th Structures, Structural Dynamics, and Materials Conference, Part 1, 1985, pp. 704-712.
2. Winegar, S. R.: SINDA-NASTRAN Interfacing Program Theoretical Description and User's Manual. NASA TM 100158.
3. Sharp, G. R.; Acosta, R. J.; Bobinsky, E. A.; and Shaker, F. J.: A Conceptual System Design for Antenna Thermal and Dynamic Distortion Compensation Using a Phased Array Feed. NASA/DOD Control/Structures Interaction Technology 1987 pp. 145-162.

