

N90-19969

## FREQUENCY STABLE HIGH POWER LASERS IN SPACE

232  
98  
V

50385476

ROBERT L. BYER  
Department of Applied Physics  
Stanford University  
Stanford, CA 94305

## I. INTRODUCTION

Two years ago during a visit to Boulder, Colorado, Professor Peter Bender introduced me to his dream of a laser heterodyne gravity wave antenna that would operate in solar orbit with a one million kilometer path length. I was asked what progress might be expected in laser technology that would be appropriate for operation of this space-based gravity wave detector.

The rapid progress in diode lasers (Streifer *et al.* 1988) coupled with the energy storage and potentially sub-Hertz linewidths of solid state lasers (Byer 1988, Fan and Byer 1988) and the possibility of efficient frequency conversion by nonlinear optical techniques (Kozlousky *et al.* 1988) defines a technology that is appropriate for laser interferometry in space.

This paper summarizes the present status of diode-laser-pumped, solid-state lasers and projects future progress in areas of linewidth control, high average power, operating efficiency, and operational lifetimes that are essential for space-based applications.

## II. DIODE LASER PUMPED ND:YAG LASER OSCILLATOR

In 1985, Zhou *et al.* demonstrated a diode-laser-pumped standing wave monolithic Nd:YAG laser oscillator that operated at 1,064 nm. That experiment illustrated that diode pumping of Nd:YAG was feasible with only a 2 mW cw threshold and with a slope efficiency of 25%. Further, the monolithic 5-mm-long crystal oscillator was isolated from most laboratory-induced sources of acoustic noise and operated with a linewidth of less than 3 kHz. The standing wave geometry, however, was susceptible to feedback of optical radiation and did not oscillate in a single frequency at higher output power levels.

To overcome the limitations of the standing wave oscillator and yet retain the advantages of the monolithic structure, Kane and Byer (1985) invented the monolithic nonplanar ring resonator. This oscillator combined the elements of an optical diode, which forced oscillation in a single direction, with the stability of the millimeter-dimensioned monolithic construction. With diode laser pumping, over 50 mW of single frequency output power was obtained with kilohertz linewidths (Kane *et al.* 1987a). The nonplanar ring oscillator has been an essential element in progress in laser linewidth studies, in efficient nonlinear frequency conversion into the green, and in the demonstration of coherent laser radar at 1,064 nm. The nonplanar ring oscillator's immunity to optical feedback, its single frequency output at high power levels, and its high resonator, Q, make it the oscillator of choice for linewidth-reduction studies. Figure 1 shows a schematic of a diode-laser-pumped nonplanar ring oscillator. Recent work has demonstrated that these oscillators operate with linewidths less than 1 kHz, that they can be offset frequency-locked, and that they can be phase-locked. Future work is expected to reduce the linewidth to less than 1 hertz and to lock the frequency-doubled output onto the 300 kHz-wide subdoppler hyperfine component of the iodine molecule at 532 nm. Beyond that, it is

possible to conceive of stabilization of the output of these monolithic devices using ions, or a single ion, stored in an optical or radio frequency trap as an optical clock.

### III. 56%-EFFICIENT, SECOND-HARMONIC GENERATION

Techniques must be used to increase the power level in nonlinear crystals to efficiently frequency double the milliwatt power level, cw diode-pumped Nd:YAG oscillators to generate green output at 532 nm. Internal second-harmonic generation (SHG), where the nonlinear crystal is placed within the laser resonator, is one approach for SHG (Fan *et al.* 1986, Baer 1986). Early experiments yielded milliwatt output power levels in the green at conversion efficiencies near 10%. However, internal SHG requires that optical elements be placed within the laser resonator, thus foreclosing the option of the stable monolithic designs and adding complexity to the laser oscillator structure.

An alternative is to externally resonate the fundamental field within the nonlinear crystal. Kozlovsky *et al.* recently demonstrated 56% SHG efficiency using the external resonant approach and converted 52 mW of 1,064 nm to 30 mW of cw 532 nm which had the stability and linewidth of the infrared laser source (Kane *et al.* 1986). The experiment, which used a monolithic ring resonator in a MgO:LiNbO<sub>3</sub> nonlinear crystal is shown in Figure 2. Kozlovsky *et al.* (1988) used a diode-laser-pumped nonplanar ring oscillator as the laser source in these elegant experiments. The generation of green radiation allows frequency locking onto hyperfine components of the iodine molecule as a first step toward an absolutely stable laser oscillator. The high conversion efficiency into the green also allows the contemplation of a green source of radiation to replace the argon ion laser as the preferred laser source for gravity wave interferometry.

### IV. HIGH-AVERAGE POWER, HIGH-EFFICIENCY LASER OSCILLATORS

To meet the future requirements for gravity wave interferometry in space, the diode-laser-pumped, solid-state laser power must be substantially increased. Fortunately, work is underway with the goal of improving the power level and the efficiency of diode-laser-pumped, solid-state laser oscillators.

The first approach taken to increase the available power, from narrow linewidth laser oscillators, was the demonstration of a 62 dB gain multipass slab geometry Nd:YAG laser amplifier which amplified cw input power at the milliwatt level to kilowatt peak powers for microsecond-long pulse durations (Kane *et al.* 1986). The output of this amplifier was used to demonstrate the first coherent laser radar at 1,064 nm. The Stanford coherent laser radar system used the diode-laser-pumped, nonplanar ring oscillator, the multipass slab amplifier, and single mode glass fiber to collect the returned signal and mix it with the local oscillator (Kane *et al.* 1987b).

In a second approach to obtain higher power levels, a two-dimensional diode laser array was used to pump miniature slabs of Nd:YAG and Nd:Glass. This experiment demonstrated over 0.5 Watt of average output power at 4% overall electrical-to-optical efficiency, and demonstrated that the slab geometry had advantages for diode laser pumping (Reed *et al.* 1988). Since these early results, electrical-to-optical efficiencies of greater than 10% have been demonstrated (Byer 1988).

Based on the diode array pumping of a miniature slab geometry laser oscillator, scaling to higher output power levels is now possible with high confidence. Since the present cost of a two-dimensional array of diode lasers is prohibitive, an alternative approach, shown in Figure 3, has been proposed (Fan and Byer 1988). In this approach, many individual diode lasers, coupled through fibers, are used to pump a slab geometry solid-state laser. The advantages of this approach are the lower cost of the individual diode laser sources, the separation of the diode laser cooling and electrical circuits from the laser itself, and the soft failure mode inherent in many-source pumping. An added benefit is that the laser can be upgraded easily by replacing diodes by increased power diodes, as the technology allows, without redesigning the entire laser system. This design also takes advantage of the projected decrease in cost per Watt of diode laser power by a factor of four each year.

To meet the gravity wave interferometry requirements, we propose to demonstrate a 20 W, cw, single frequency, slab geometry Nd:YAG laser oscillator pumped by 60 1-Watt diode lasers. The overall efficiency of this laser is expected to exceed 10%. That is, for 200 W of electrical input, the laser will generate 20 W of optical output at 1,064 nm. We plan to injection-lock this power oscillator with a nonplanar ring oscillator to obtain single frequency operation. We also plan to frequency double this laser oscillator using external resonant doubling in MgO:LiNbO<sub>3</sub>. This source should be both a direct replacement for the argon ion laser and the first step toward a laser oscillator that can meet space-based operational requirements.

#### SUMMARY

Recent progress in diode-laser-pumped, solid-state lasers and in efficient nonlinear frequency conversion has opened new possibilities for coherent laser interferometry. The next generation of laser sources should meet the most demanding requirements for gravity wave interferometry. With further evolution, narrow linewidth lasers should open the possibility of deep space coherent communication or additional relativistic measurements based on astrometry.

#### REFERENCES

- Baer, T. 1986, *J. Opt. Soc. Am B*, 3, 1175.  
 Byer, R. L. 1988, "Diode Pumped Solid State Lasers," *Science* 239, 742.  
 Fan, T. Y., et al. 1986, *Opt. Letts*, 11, 204.  
 Fan, T. Y., and Byer, R. L. 1988, *IEEE Journ Quant Electr.* QE-24, 895.  
 Kane, T. J., and Byer, R. L. 1985, *Optics Letts* 10, 65.  
 Kane, T. J., et al. 1986, *Opt. Letts*, 11, 216.  
 Kane, T. J., et al. 1987a, *Opt. Letts*, 11, 175.  
 Kane, T. J., et al. 1987b, *Opt. Letts*, 12, 239.  
 Kozlovsky, W. J., et al. 1988, *IEEE Journ Quant. Electr.* QE-24, 913.  
 Reed, M. K., et al. 1988, *Opt. Letts*, 13, 204.  
 Streifer, W., et al. 1988, "Advances in Diode Laser Pumps," *IEEE Journ Quant. Electr.* QE-24, 883.  
 Zhou, B. K., et al. 1985, *Optics Letts* 10, 62.

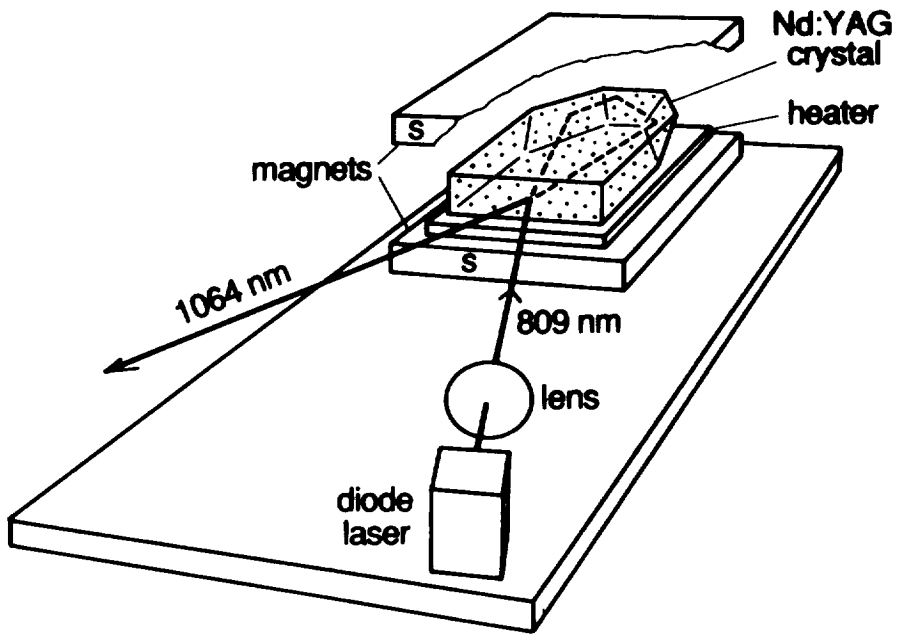

FIG. 1.—A diode-laser-pumped nonplanar ring oscillator

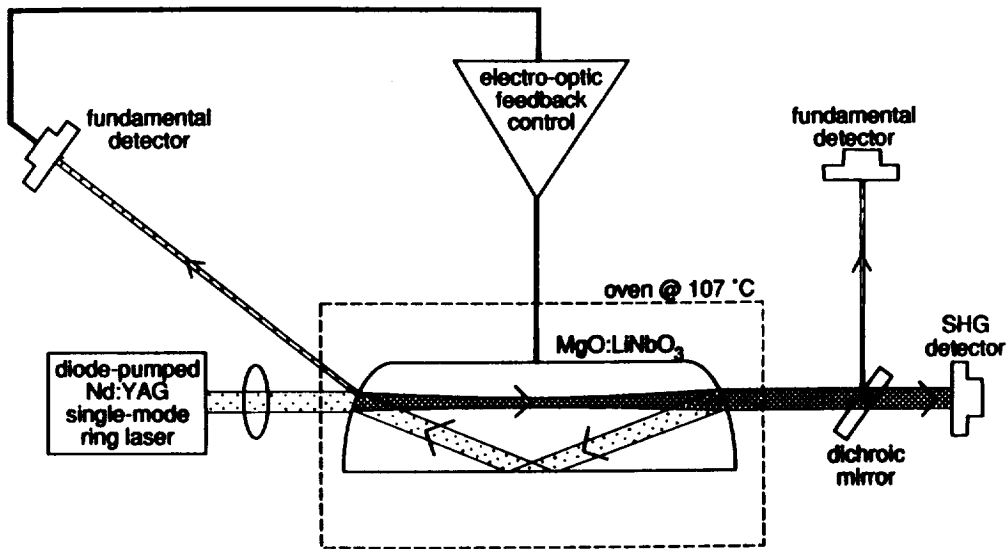

FIG. 2.—The 56%-efficient, external resonant ring doubler

### FIBER COUPLED DIODE LASER PUMPED SLAB LASER

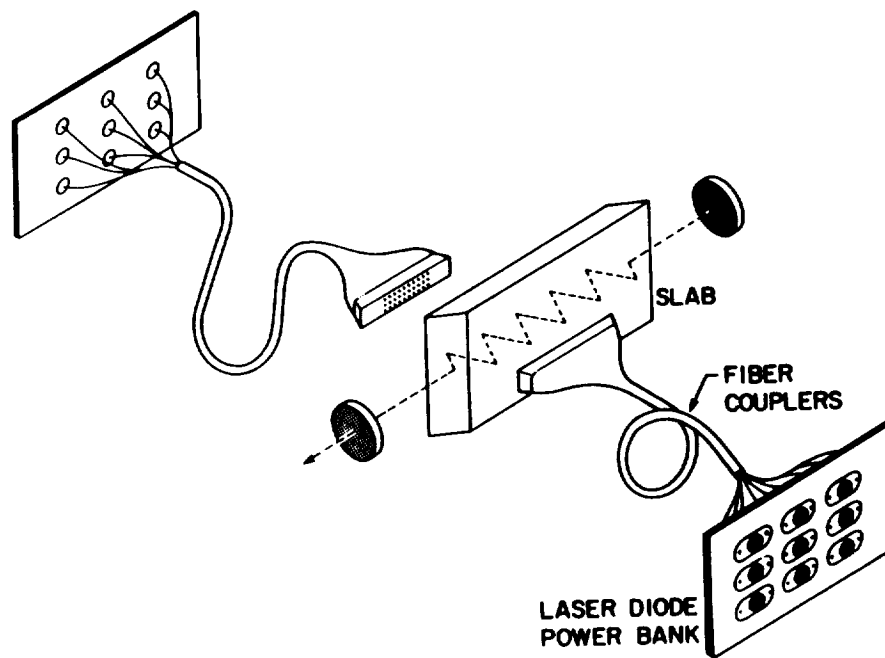

FIG. 3.—Slab laser pumped by many diode lasers coupled through optical fibers