

NASA Technical Memorandum 102530

Design and Test of a Compact Optics System for the Pool Boiling Experiment

Jerri S. Ling and James R. Laubenthal
Lewis Research Center
Cleveland, Ohio

March 1990

(NASA-TM-102530) DESIGN AND TEST OF A
COMPACT OPTICS SYSTEM FOR THE POOL BOILING
EXPERIMENT (NASA) 17 p CSCL 22A

N90-20253

Unclass
63/29 0275318

NASA



DESIGN AND TEST OF A COMPACT OPTICS SYSTEM FOR THE POOL BOILING EXPERIMENT

Jerri S. Ling and James R. Laubenthal
National Aeronautics and Space Association
Lewis Research Center
Cleveland, Ohio 44135

SUMMARY

The experiment described here seeks to improve the understanding of the fundamental mechanisms that constitute nucleate pool boiling. The vehicle for accomplishing this is an investigation, including tests to be conducted in microgravity and coupled with appropriate analyses, of the heat transfer and vapor bubble dynamics associated with nucleation, bubble growth/collapse and subsequent motion, considering the interrelations between buoyancy, momentum and surface tension which will govern the motion of the vapor and surrounding liquid, as a function of the heating rate at the heat transfer surface and the temperature level and distribution in the bulk liquid.

The experiment is designed to be contained within the confines of a Get-Away-Special Canister (GAS Can) installed in the bay of the space shuttle. When the shuttle reaches orbit, the experiment will be turned on and testing will proceed automatically.

In the proposed pool boiling experiment a pool of liquid, initially at a precisely defined pressure and temperature, will be subjected to a step imposed heat flux from a semitransparent thin-film heater forming part of one wall of the container such that boiling is initiated and maintained for a defined period of time at a constant pressure level. Transient measurements of the heater surface and fluid temperatures near the surface will be made, noting especially the conditions at the onset of boiling, along with motion photography of the boiling process in two simultaneous views, from beneath the heating surface and from the side. The conduct of the experiment and the data acquisition will be completely automated and self-contained. For the initial flight, a total of nine tests are proposed, with three levels of heat flux and three levels of subcooling.

This paper documents the design process used in the development and check-out of the compact photographic/optics system for the pool boiling experiment.

INTRODUCTION

Requirements for the proper functioning of equipment and personnel in the space environment of reduced gravity and vacuum, as will be necessary in future space station modules and space platforms, introduce unique problems in temperature control, power generation, energy dissipation, the storage, transfer, control, and conditioning of fluids (including cryogenic liquids), and liquid-vapor separation.

Nucleate boiling is an important mode of heat transfer in that relatively small temperature differences can provide large rates of heat transfer, which can result in significant economic and other benefits associated with the smaller heat transfer areas necessary to accomplish a given function.

A significant distinction is made between pool boiling and flow boiling when considering applications in the space environment of microgravity, since these two processes may arise in quite different specific technical applications. Pool boiling, for example, would be important for the short-term cooling of high-power electronic or other devices, and for the long-term space storage of cryogenics. Flow boiling, on the other hand, occurs in applications where liquid flow is imposed externally, such as in Rankine cycle vapor generation or in thermal energy management using pumped latent heat transport.

The effective and enhanced applications of both nucleate pool and forced convection boiling requires a sound understanding of the mechanisms governing the processes. The vapor removal from the vicinity of the heater surface, as understood to this point, occurs primarily by buoyancy, in the case of pool boiling and bulk liquid inertia in the case with forced convection. Although the variation of both gravity and forced flow are known to influence the overall heat transfer processes, other forces or potentials are acting as well, and the relative significances of these is as yet poorly understood.

The purpose of this experiment is to determine the effect of heat flux and liquid subcooling on nucleate pool boiling in a long-term reduced-gravity environment. The principal investigator seeks to analytically and experimentally determine the heat transfer and vapor bubble dynamics associated with nucleation, bubble growth/collapse, and subsequent motion. The interrelations between buoyancy, momentum, and surface tension which govern the motion of the vapor and surrounding liquid will be evaluated as a function of the orientation and heating rate of the heat transfer surface, and the temperature level and distribution in the bulk liquid.

The experiment consists of a test chamber with integral pressure and temperature control capability. Photographic data is obtained using a 16 mm film camera. The data and control system is a STD bus computer with 120K word permanent data storage capability in EEPROMS. The power system consists of a 28 V dc battery with the necessary power supplies to provide the required voltages and currents to operate the experiment. The experiment test sequence is programmed in software but, wherever possible, logic functions are implemented in hardware to minimize the software development requirements.

Strip heaters are used to raise the test chamber to the test temperature of about 125 °F. Photographic lighting is provided by redundant miniature incandescent flood lamps.

Thin film heaters are used to initiate the nucleation process. A thin layer of gold is sputter-deposited onto a quartz substrate (window) to provide a smooth flat surface which is transparent enough to view bubble formation from below. Both a side view and the underside view are filmed and combined on one frame of film via the optics system. See figure 1.

OPTICS SYSTEM CONCEPT

The pool boiling experiment (PBE) was conceived by Dr. Herman Merte at the University of Michigan (refs. 1 and 2). The experiment hardware was designed and developed by the PBE Project Team at NASA Lewis Research Center.

Simply stated, the purpose of the experiment is to study nucleate pool boiling of refrigerant R-113 in the microgravity environment of space. The primary method of recording experimental events is via 16 mm high-speed photography linked to a data acquisition system. The data (experimental parameters) are synchronized with film exposed during the same time period. The film and data will be analyzed by Dr. Merte (the principal investigator) once it is processed and duplicated.

The optics system is vital to the success of the experiment. This paper details the design and test process involved in the development of the compact optics system for the PBE. The information in this paper could be useful in developing optics systems for future experiments.

Optical Science Requirements Summary

Optical requirements for the pool boiling experiment (PBE) are necessarily exacting due to the accuracy of the measurements needed for analysis of this phenomenon, and the fact that the experiment will be performed inside the limited confines of a Get-Away-Special (GAS can) container. These requirements are summarized in the paragraphs below.

The test matrix consists of nine tests, each lasting a maximum of 2 min, with a waiting/settling period of 30 min between each test. For planning purposes, photography would begin at the onset of heating at 10 pictures per sec (pps) and will remain at 10 pps until approximately 1 to 2 sec before the predicted onset of nucleation. At this time the cameras will be set at 100 pps for an average of 6 sec (some tests more, and some less) for each of the 9 tests for a total of 54 sec at 100 pps to capture the spread of nucleation over the surface. The camera will then be set at 10 pps for the remainder of each test. The time interval between the onset of heating and the expected onset of nucleation was determined approximately by ground-based testing at each experimental condition.

The field of view should include the surfaces of both gold film heaters from the side and from below, placing both views on the same film frame by means of mirrors. The side view should include an area at least 2 in. above the gold film heaters. Care must be taken to provide the same optical path length for both views for proper focus.

The thermistors located in the vicinity of the heating surface must be in the field of view and in focus to provide a size reference scale. The thermistors are used to verify temperature uniformity near the heater surface and throughout the test chamber.

The film should be fine grained to allow detection of an object as small as 0.007-in. in size. In addition, it should not be subject to breakage at a frame rate of 100 pps. The operating temperatures and nitrogen atmosphere demand that a film be used which has a stable emulsion which is not subject to embrittlement or delamination. Lights should be positioned such that undesired refraction at the liquid-vapor interface of large bubbles is minimized.

The environment inside of the container places additional requirements on the optics system components. The launch G loading in the shuttle bay requires

firm mounting and fixing of all optical surfaces and lens settings. The filaments of the lamps must be able to stand the vibration levels, operate at varying voltage levels depending on battery state-of-charge, and respond quickly to the current surges present at turn-on for the entire test matrix.

Preliminary Configuration for Composite Picture

The image on each frame of film is required to include two views of the heater surfaces in order to completely document the formation of R-113 bubbles on film. Two-thirds of the image is reserved for filming the side view of forming bubbles. This view will allow the principal investigator to measure the bubble height, one of the parameters in his calculations. The remaining third of the image is reserved for viewing the forming bubbles through the underside of the gold heaters in order to obtain diameter measurements of newly forming bubbles.

A question arises as to the feasibility of filming pool boiling with the required complex composite picture within the space allowed inside the container while still leaving sufficient area to accommodate the pressure, temperature and power control instrumentation necessary to operate the experiment. To accomplish this composite image, it is necessary to manipulate the views through two windows, located 90° from one another, via mirrors. In order to test the feasibility of the composite picture concept, an arbitrary object which approximated the area of the gold heater surfaces was placed in front of a video camera and a crude composite image was constructed in real time and observed on a video monitor.

Equipment. - The equipment used to determine feasibility of the composite image consisted of four optical quality front surface mirrors, a video camera equipped with a 35 mm C-mount lens, a test object, and a small black-and-white video monitor to display the image as it was manipulated. More than adequate lighting for the test was supplied by one 500 W photo flood lamp.

Feasibility check. - With the equipment previously described, it was possible to determine a crude optics layout which yielded an acceptable composite image of the test object. At this point, the emphasis was directed toward attaining the 2/3:1/3 ratio image without considering image resolution, or exact lighting necessary. Attention was given, however, to the amount of space required for positioning the mirrors and the camera in order to achieve the desired image. This is an important prepackaging consideration for any experiment in a container of limited size.

Feasibility check results. - Test results indicated that it is possible to film a composite image of a test object using a minimum amount of space and equipment. A lens of focal length between 35 and 40 mm appeared to yield the proper image size. Figure 2 is an illustration of the optical configuration which resulted from preliminary testing.

OPTICS SYSTEM CONCEPT/LAYOUT

The following sections will describe the process used to design the optics system for this experiment.

Mathematical Model

The first step in a design process of this kind should be a mathematical approximation of what is needed to accomplish the end result. A desirable way to do this is to construct a life size schematic drawing of the components in their relative locations. Certain component locations will be fixed and measurable which will lead to the numerical determination of the others.

The first parameters which can be represented are the approximate focal length and view angle of the lens. These parameters are properties of the focal length selected (from the feasibility check) and, to some small degree, the lens selected. Since approximate mirror angle and location with respect to the subject were previously determined (also from the feasibility check), rays representing optical paths and image ratios can now be included on the schematic. The lens view angle determines the approximate mirror size and location. When the path lengths are measured, they may or may not be similar. It is important for both optical paths to be as numerically equal as possible, or a portion of the composite image will appear out of focus. Adjusting optical paths requires slight relocations of mirrors and some mirror angle adjustment. This is somewhat trial and error until the designer becomes familiar with the effects of individual mirror motion on the final image. The schematic drawing is very helpful in illustrating this relationship.

The reiteration steps eventually lead to a drawing of mirror positions and angles necessary for equal optical paths. Measurements should be obtained directly from the schematic and confirmed using hardware which simulates flight configuration as near as possible.

Confirmation of Concept

The layout of the mirrors with respect to the camera and the test subject should be confirmed using the measurements obtained from the schematic.

The equipment used for design confirmation was the same as for the feasibility check except for the test object. It is necessary to have a test object which closely approximates the dimensions of the actual subject. The actual subject is the surface of two side-by-side gold sputtered heaters, and an area about 3 in. from the surface of the heaters. A military resolution target etched on a glass slide was used to simulate the heater surface and a ruler oriented 90° to the target surface was used to simulate the distance of interest from the heater surface. The video camera was positioned where the flight camera would be located. The composite image was viewed on the video monitor.

This test confirmed the layout design was very close to correct using a 35 mm lens and the simulated subject. It should be noted that these tests were conducted using equipment which simulated the positions of flight hardware. This test was repeated using a test chamber which was instrumented with a stirrer, thermocouples, windows for lighting and viewing, and operational gold sputtered heaters. Again, the test confirmed that the layout was near final using a 35 mm lens.

OTHER OPTICS SYSTEM DETERMINATIONS

Confirming the layout of the optics system is an important step in the complete optics system design, but it is by no means the last step in the process. There are additional considerations which may or may not impact the layout. Some of these considerations include proper light level, image resolution, fluid temperature increases versus light level, and lens selection and settings. Following is a description of the testing performed to make the determinations just mentioned.

Light Level

The flight-like test chamber was used to do the lighting determination. It was filled with R-113 so that transmission of light through R-113 would be known. The two lighting windows in the test chamber allowed the use of two 20 W/28 V mini floods. The lamps used were of a type commonly used in drop tower testing. The mini floods perform well under a variety of operating voltages and have a diffusion coating for adequate light dispersion. A camera like the one which will be used for flight (Redlakes Corporation Locam) was fitted with a 40 mm f/1.5 lens. The film chosen for testing as well as for flight was Kodak RAR 2498 Estar-AH base black and white film. This film has a stable emulsion in a variety of temperatures and has superior strength and elasticity characteristics (necessary in high-speed photography). Grain size of this film is more than adequate for filming objects of the size in question (7 mil).

Film was exposed at various aperture settings while holding light level constant. The tests were repeated for five lamp voltages in the 4 to 28 V range. Two different frame rates will be used in flight, and testing was completed at both 10 and 100 pps. Because of power system design considerations, a lamp voltage of 28 V is desired for flight. The lens obtained for flight should be f/2.0 or faster. If the flight lens differs significantly from the test lens it will be necessary to repeat the previous tests.

Resolution/Fluid Mixing Test

The optics system was required to support several tests other than those for optics design determination. One of these tests was to document on film the operation of the stirrer motor to evenly distribute the R-113 in the test chamber for temperature control and equilibration. Tiny Arimide fibers were added to the R-113 fluid to detect flow patterns and fluid distribution. Fortunately, the fibers were very uniform in thickness (0.5 to 0.8 mils) and showed up quite well on film. The thickness of the fibers was confirmed by using a scanning electron microscope and analyzing the greatly magnified pictures. Since the fibers were able to be resolved in the filmed test, this was also adequate to confirm the 7 mil resolution requirement of the principal investigator.

Lighting versus Fluid Temperature

In this test, candidate lamps were screened to determine their effect on the temperature of the R-113 fluid. Thermocouples were located within the test chamber in order to map the temperatures in key areas. Thermocouples were also attached to the inner surface of the lighting windows to measure heat input at the window/R-113 interface. In addition to testing the lamps, various colored glass (simple) IR filters were tested in conjunction with the lamps. In flight, the lamps will be used for intervals of 2 min. Fluid temperature data was taken at 0, 30, 60, and 120 sec in order to observe where temperature increases were concentrated, and whether the IR filters were helpful in delaying temperature increases.

Temperature increases of as high as 8° were noted at the inner surface of the lighting windows. The bulk of the R-113 fluid remained constant. Fluid at the windows showed a temperature rise of only 2 °F. Results of this test were not surprising due to the insulating properties of R-113. The 20 W/28 V lamps proved to be the best choice because they caused the least fluid temperature increase. Simple IR filtering had little effect on this increase in fluid temperature. It should be noted that the windows used in the test chamber were pyrex and not the quartz flight windows. The heat transfer properties of quartz are more desirable than pyrex which indicates that this test can be considered a worst case.

Lens Selection

Since the test chamber provides a subject which is near to flight hardware, a lens can be selected based on desired image and available light. A variety of lenses were tested in order to obtain an image which would nearly fill the film frame. If other objects need to be included in the frame, such as timing lights, some consideration must be allowed in planning the image composition.

A 40 mm lens appears to be optimum for this application. It is desired to have an f/2.0 or faster in order to have some latitude in exposure control. A fixed focal length lens is more desirable than a zoom.

Camera

The camera chosen for this experiment is a 16 mm Redlakes Locam II with a 450-ft film capacity. It will be the standard 28 V dc version in every respect except for the motor. Instead of using the standard motor which allows a maximum frame rate of 500 pps, a motor normally used on the 120 V ac camera will be substituted. Doing this accomplishes several things. It decreases the steady-state running current by a factor of 3, and the peak running and starting current by about a factor of 10. Beside the obvious power saving, this decreases the amount of electrical motor interference that will be produced, and eases the requirements on power line filtering required. The negative aspects of this change are that the maximum frame rate is now limited to 150 pps and 28 V dc, and the starting time has been a little more than doubled to 1 sec at 100 pps. Neither of these factors limits the performance for this application.

Nominal Film Usage

An estimate of the film usage for all 9 tests is 15 480 frames of an 18 000 frame roll. These values have been arrived at as follows:

There are 9 tests of which 7 tests are for 2 min and 2 tests for 1 min. Each test has 6 sec at 100 frames-per-sec and the duration at 10 frames-per-sec. Therefore:

$$\begin{aligned} 9 \text{ tests} \times 6 \text{ sec} \times 100 \text{ frames/sec} &= 5\,400 \text{ frames} \\ 7 \text{ tests} \times 114 \text{ sec} \times 10 \text{ frames/sec} &= 7\,980 \text{ frames} \\ 2 \text{ tests} \times 54 \text{ sec} \times 10 \text{ frames/sec} &= \underline{1\,080 \text{ frames}} \\ &14\,460 \text{ frames} \end{aligned}$$

$$\begin{aligned} 3 \text{ ft of film to thread camera} &= 120 \text{ frames} \\ 9 \times 50 \text{ frames (average to ramp up to speed)} &= 450 \text{ frames} \\ 9 \times 50 \text{ frames (average to ramp down to speed)} &= \underline{450 \text{ frames}} \\ \text{(Estimated)} &1020 \text{ frames} \end{aligned}$$

$$\begin{aligned} \text{Total frames used } 14\,460 + 1020 &= 15\,480 \\ \text{Spare frames } 18\,000 - 15\,480 &= 2520 \end{aligned}$$

Once systems testing has verified the actual frame usage requirements, any spare frames will be assigned to selected test sequences by the Principal Investigator. Film leader of 200 frames (enough to pass film exposed during loading) will be included in the final usage determination.

Preliminary Results

In the early phases of the optics system design, the feasibility of the composite picture was verified. Experimentation with laboratory test chambers resulted in the choice of a fine grained film (Kodak ESTAR-AH 2498) which yields more than acceptable resolution (0.7 mils). A suitable high-speed camera (16 mm Redlakes Locam II) was used for making lens settings and lamp voltage determinations for proper exposure of the film at the two-frame rates. A neutral density filter (factor of approximately 0.4) was needed on the side viewport in order to compensate for the exposure differences in the two views. The gold film heaters acted as a filter which resulted in the side view being much brighter than the view through the heater. The neutral density filter was a simple way to eliminate this problem. An f/2.0, 40 mm, fixed focal length lens was determined to give the optimum field of view for filming a 2-in. by 2 in. target (estimated to be a possible size of a bubble during flight).

Experimentation with the near flight hardware revealed some areas which were considered to be borderline. The main areas of concern were determined to be the following: (1) sufficient light input/exposure for filming at 100 pps, and (2) the effect on thermistors of heat input from photographic lamps (different from heat input to fluid tests performed). Testing was done in order to quantify and attempt to correct these problem areas. The second is more component specific and is not directly related to the optics requirements. However, some altering of the optics system may be required in order to eliminate thermistor effects observed from direct exposure to incident light

from the lamps. The following is a description of testing which was performed in order to optimize the PBE optics system design. The two areas of concern will be addressed separately.

Light input at 100 pps. - It is desirable to have as much light as possible for this frame rate in order to get the maximum depth of field. Various means of increasing exposure were investigated and are briefly explained below:

Alternate Light Source: The use of brighter, more efficient light sources such as tungsten-halogen lamps may be preferable to the present tungsten lamps. Durability of the halogen lamps was determined. Approximately five candidate lamps with slightly different filament configurations were identified. These lamps are undergoing vibration and thermal testing. Test results have been encouraging and are presented in table 1.

Lamp Position: There are three basic lamp positions which can be used in the present hardware configuration. The optimum position was determined by using a light measuring device in place of the camera lens and altering lamp position in real time (while observing changes in light intensity with the meter). The optimum position occurs when the amount of light reaching the camera is at a maximum. This was achieved by positioning the lamps so that both are pointing toward the teflon baffle (located at the rear of the chamber) at an angle of 35 to 45°. The teflon baffle serves as a light dispersion device, or a light diffuser.

Alternate Film: Although use of alternate (Kodak 2484) film allowed a one or two stop increase in exposure, the larger grain size made it unsuitable for use. A resolution test was run using the same kind of Arimide fibers and methodology which was described earlier in the optics design discussion. Results showed that the fibers were barely able to be resolved. This film was determined to be unsuitable for this experiment because of the resolution and the difficult/costly processing method. The film chosen for flight will be the baseline Kodak RAR 2498 ESTAR-AH base.

Lamp Voltage: Operating lamps at higher than their rated voltage is another way to increase the amount of light. The baseline tungsten lamps are rated at 28 V, but have been operated as high as 50 V without failure. Filming tests were run using these lamps at 35 and 40 V. Forty volts is a significant increase over the rated 28 V, but the life of the lamp is still within acceptable limits. Testing at 100 pps yielded excellent exposure at f/2.8 and even at f/4.0. The depth of field at 35 V is 3 to 4 times better than that at 28 V (f/1.5). Testing was conducted to see if the voltage could be further reduced and yet still allow a lens setting of f/2.8 at 100 pps. The closer the lamp voltage is to 28 V, the smaller the impact on the power subsystem design. Results show that the optimum exposure at 100 pps occurs at 32 V for the tungsten lamps. A similar test was conducted for promising lower voltage halogen lamps. The halogen lamps are typically rated at 12 to 14 V. The optimum exposure at 100 pps occurs at 14 V for the halogen lamps tested.

Lighting versus temperature effects. - Significant progress has been made in this area. Different lamp/filter configurations were investigated in order to eliminate the thermistor errors observed when incident light (line-of-sight) caused thermistors to indicate the fluid temperature was higher than it actually was. The following types of filters were tested for their ability to redirect or block IR while still allowing the transmission of visible light: simple IR colored glass filters, cold mirrors, hot mirrors (refs. 3 and 4) and 1/4-in. water barrier filters. The water barrier filter is the most effective in an earth-based laboratory environment, but is considered impractical for a small complex payload such as PBE. The water filter results are included for comparison with the results obtained from other types of filters in table 2. The simple IR filters serve as heat absorbing devices. The hot mirrors allow visible light to pass through them while absorbing and reflecting IR in the opposite direction. The cold mirrors allow IR to pass through while reflecting visible in the opposite direction. When properly oriented, the cold mirrors are the most effective. However, the location and physical support for this kind of mirror in a structure where space is at a premium can be difficult to achieve. Cold mirror coatings are used on the reflectors of some halogen lamps which were tested. This type of reflector along with a hot mirror coating on the surface of the lighting windows will significantly reduce the amount of IR reaching the thermistors. Applying a black or reflective paint to the tip of the lamp to block line-of-sight IR transmission, in conjunction with the aforementioned filtering approach will minimize the IR input.

Another approach to this problem would be to alter the chamber design in a way which blocks line-of-sight IR transmission to the thermistors. Such a chamber design was assembled and tested. The thermistor effect was significantly reduced or eliminated with the new design without filtering. Design shown in figure 3 represents a significant amount of hardware alteration. Therefore, the new design is considered as a fallback design should filtering and lamp choice fail to be insufficient at reducing the thermistor effect.

CONCLUSIONS

Halogen lamps have proven to be adequate for this application. They have withstood launch G loads and continue to operate in the absence of convection (vacuum chamber test). A 28 V/25W halogen lamp allows for complete redundancy in case one lamp should burn out. Halogen lamps reduce heat input into the test chamber while still providing the correct amount of light. Use of halogen lamps allows an increase in the depth of field because lens aperture can be reduced by one $f/\#$ to 2.8.

The thermistor effects can be minimized either by altering the test chamber design as earlier suggested or by using a combination of IR filtering methods. The combination involves depositing a hot mirror-type coating onto the outer surface of the lighting windows (or on the lamp cover), and using cold mirror-type dichroic reflectors on the lamps. In addition, a coating on the tip of the bulb is advantageous in eliminating line-of-sight IR transmission.

ACKNOWLEDGEMENTS

The authors would like to thank the NASA Lewis Research Center Photo Lab and IRL technicians for their assistance and support.

REFERENCES

1. Merte, H., Jr.: Study of Nucleate Pool Boiling Under Microgravity. Internal Project Report, University of Michigan, Mar. 1989.
2. Merte, H., Jr.: Combined Roles of Buoyancy and Orientation in Nucleate Pool Boiling. Collected Papers in Heat Transfer 1988, K.T. Yang, ed., Vol. 2, ASME, 1988, pp. 179-186.
3. Walker, E.D.; and Slater, H.A.: Method of Reducing Temperature in High-Speed Photography. NASA TM-83620, 1984.
4. Slater, H.A.: Reduction of Temperature Rise in High-Speed Photography. NASA TM-100222, 1987.

TABLE 1. - LAMP VIB. TEST RESULTS
 [X-axis is the same as VIB. axis. Y-axis is normal
 to VIB. axis with respect to the lamp filament.
 Sine tests run up to 2000 hz. Random level equals
 gas can spec of 13.2G RMS for 40 sec.]

Lamp used	Axis	G Level	Sine	Random
GE 1385 28 V/20 W	X Y	15 15	OK OK	-- --
Osram 64425 12 V/20 W	X Y	15 15	1200 hz OK	-- --
Thorn flt 13.8 V/25 W	X Y	15 15	OK 30 hz PIN	-- --
Sylvan. Err 14 V/25 W W/O reflect.	X Y	15 15	OK OK	OK OK
Sylvan. Err 14 V/25 W	X Y	-- 15	-- OK	-- --
Sylvan. EZX 12 V/20 W	X Y	15 15	OK OK	OK OK
GE ESX 13.8 V/25 W	X Y	15 15	OK OK	OK OK
GE 1968 28 V/25 W	X Y	-- --	-- --	-- --

TABLE 2. - IR FILTER EFFECTIVENESS

[Note: Data is for lamps at proper exposure for 10 and 100 pps. Single lamp on for 2 min, dual lamp operation for 10 sec.]

Filter used	Lamp type	Lamps used	Delta T °F
No filter	Tungsten	1	0.6
		2	.8
	Halogen	1	0.2
		2	.4
0° hot mirror	Tungsten	1	0.4
		2	.4
	Halogen	1	0.1
		2	.2
45° hot mirror	Tungsten	1	0.2
		2	.2
	Halogen	1	0.1
		2	.1
45° cold mirror	Tungsten	1	0.1
		2	N/A
	Halogen	1	0-0.1 (limit)
		2	N/A

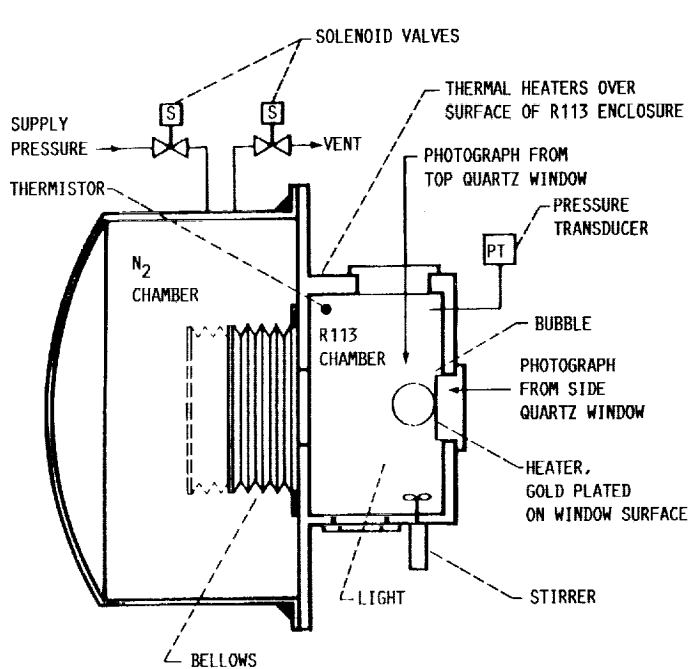

(a) TEST CHAMBER SCHEMATIC

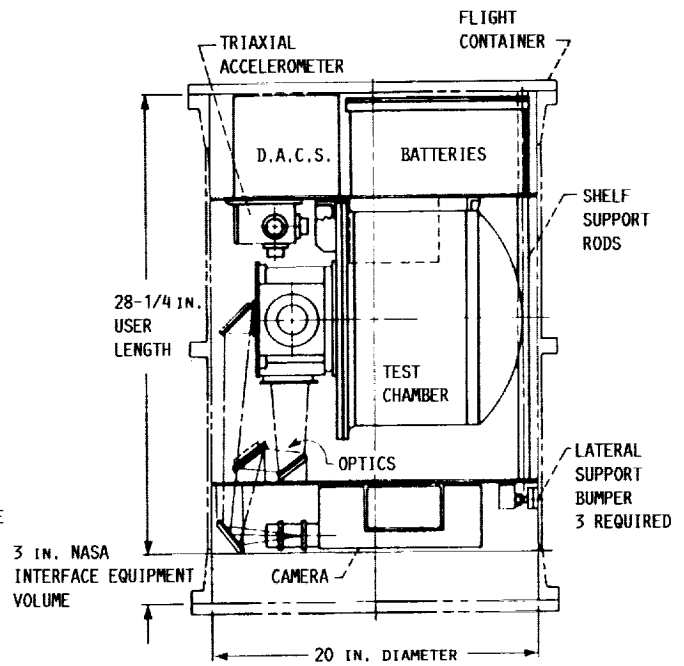

SET-UP OF EXPERIMENT IN CONTAINER.



C-88-04777

(b) TEST CHAMBER HARDWARE.

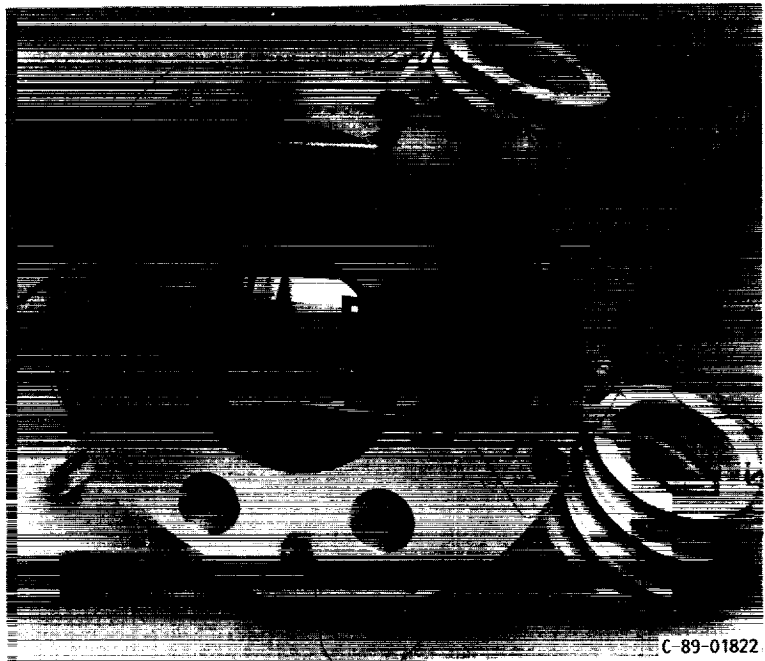

C-89-01822

(c) END FLANGE ASSEMBLY SHOWING TRANSPARENT GOLD FILM HEATERS.

FIGURE 1. - TEST CHAMBER DESIGN.

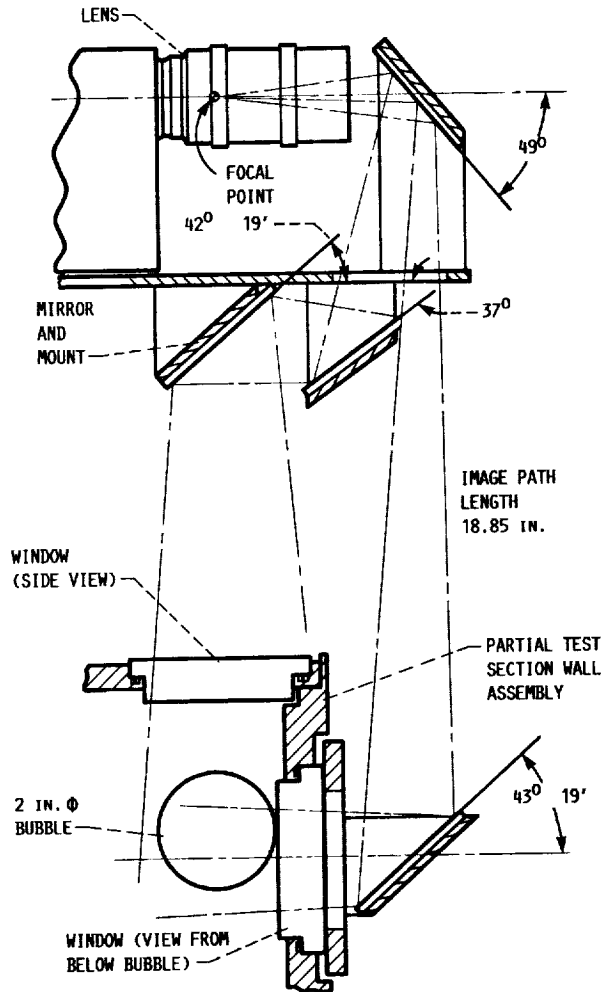
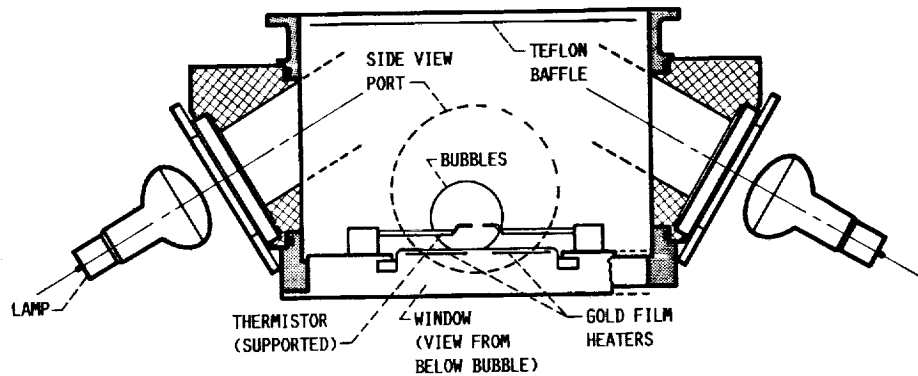

FIGURE 2. - OPTICS SYSTEM CONFIGURATION.



INSTEAD OF POINTING LAMPS DIRECTLY INTO THE CHAMBER THEY HAVE BEEN ANGLED TO PREVENT DIRECT LINE-OF-SIGHT ILLUMINATION ON THERMISTORS

FIGURE 3. - ALTERNATE TEST CHAMBER DESIGN.

1. Report No. NASA TM-102530		2. Government Accession No.		3. Recipient's Catalog No.	
4. Title and Subtitle Design and Test of a Compact Optics System for the Pool Boiling Experiment				5. Report Date March 1990	
				6. Performing Organization Code	
7. Author(s) Jerri S. Ling and James R. Laubenthal				8. Performing Organization Report No. E-5339	
				10. Work Unit No. 694-03-03	
9. Performing Organization Name and Address National Aeronautics and Space Administration Lewis Research Center Cleveland, Ohio 44135-3191				11. Contract or Grant No.	
				13. Type of Report and Period Covered Technical Memorandum	
12. Sponsoring Agency Name and Address National Aeronautics and Space Administration Washington, D.C. 20546-0001				14. Sponsoring Agency Code	
15. Supplementary Notes					
16. Abstract <p>The experiment described here seeks to improve the understanding of the fundamental mechanisms that constitute nucleate pool boiling. The vehicle for accomplishing this is an investigation, including tests to be conducted in microgravity and coupled with appropriate analyses, of the heat transfer and vapor bubble dynamics associated with nucleation, bubble growth/collapse and subsequent motion, considering the interrelations between buoyancy, momentum and surface tension which will govern the motion of the vapor and surrounding liquid, as a function of the heating rate at the heat transfer surface and the temperature level and distribution in the bulk liquid. The experiment is designed to be contained within the confines of a Get-Away-Special Canister (GAS Can) installed in the bay of the space shuttle. When the shuttle reaches orbit, the experiment will be turned on and testing will proceed automatically. In the proposed Pool Boiling Experiment a pool of liquid, initially at a precisely defined pressure and temperature, will be subjected to a step imposed heat flux from a semitransparent thin-film heater forming part of one wall of the container such that boiling is initiated and maintained for a defined period of time at a constant pressure level. Transient measurements of the heater surface and fluid temperatures near the surface will be made, noting especially the conditions at the onset of boiling, along with motion photography of the boiling process in two simultaneous views, from beneath the heating surface and from the side. The conduct of the experiment and the data acquisition will be completely automated and self-contained. For the initial flight, a total of nine tests are proposed, with three levels of heat flux and three levels of subcooling. This paper documents the design process used in the development and check-out of the compact photographic/optics system for the Pool Boiling Experiment.</p>					
17. Key Words (Suggested by Author(s)) Optics			18. Distribution Statement Unclassified - Unlimited Subject Category 29		
19. Security Classif. (of this report) Unclassified		20. Security Classif. (of this page) Unclassified		21. No. of pages 16	22. Price* A03