

N90-20467

HYDROGEN-OXYGEN PROTON-EXCHANGE MEMBRANE FUEL CELLS AND ELECTROLYZERS

R. Baldwin
NASA Lewis Research Center
Cleveland, Ohio 44135

M. Pham
NASA Lyndon B. Johnson Space Center
Houston, Texas 77058

A. Leonida, J. McElroy and T. Nalette
Hamilton Standard
Windsor Locks, Connecticut 06096

INTRODUCTION

Hydrogen-oxygen SPE fuel cells and SPE electrolyzers (products of Hamilton Standard) both use a Proton-Exchange Membrane (PEM) as the sole electrolyte. These solid electrolyte devices have been under continuous development for over 30 years. This experience has resulted in a demonstrated ten-year SPE cell life capability under load conditions.

Ultimate life of PEM fuel cells and electrolyzers is primarily related to the chemical stability of the membrane. For perfluorocarbon proton exchange membranes an accurate measure of the membrane stability is the fluoride loss rate. Millions of cell hours have contributed to establishing a relationship between fluoride loss rates and average expected ultimate cell life. Figure 1 shows this relationship. Several features have been introduced into SPE fuel cells and SPE electrolyzers such that applications requiring $\geq 100,000$ hours of life can be considered.

Equally important as the ultimate life is the voltage stability of hydrogen-oxygen fuel cells and electrolyzers. Here again the features of SPE fuel cells and SPE electrolyzers have shown a cell voltage stability in the order of 1 microvolt per hour. That level of stability has been demonstrated for tens of thousands of hours in SPE fuel cells at up to 500 amps per square foot (ASF) current density. SPE electrolyzers have demonstrated the same stability at 1000 ASF.

Many future extraterrestrial applications for fuel cells require that they be self recharged (i.e., regenerative fuel cells). This requirement means that a dedicated fuel cell and a dedicated electrolyzer work in tandem as an electrical energy storage system. Some applications may find advantages with a unitized regenerative fuel cell (i.e., one cell that operates alternately as a fuel cell and as an electrolyzer). Electrical energy storage for earth orbits via hydrogen-oxygen regenerative fuel cell systems can have specific energies in excess of 50 watt-hours/kg (Ref. 1). For extraterrestrial surface electrical energy storage the hydrogen-oxygen regenerative fuel cell can have significantly increased specific energies:

- Mars Base ~ 500 Watt-hours/kg
- Lunar Base ~ 1000 Watt-hours/kg (Ref. 2)

To translate the proven SPE cell life and stability into a highly reliable extraterrestrial electrical energy storage system, a simplification of supporting equipment is required. Static phase separation, static fluid transport and static thermal control will be most useful in producing required system reliability. Although some 200,000 SPE fuel cell hours have been recorded in earth orbit with static fluid phase separation, no SPE electrolyzer has, as yet, operated in space.

Under NASA sponsorship a flight experiment of a unitized regenerative fuel cell is being studied. If selected for actual flight under the NASA OAST Outreach Project, several advanced features will be tested in space.

The objective of the flight experiment is to test the space viability of the incorporated features, and not to imply that the specific configuration of the flight experiment is optimum for any given extraterrestrial application. With a successful flight experiment, supported by terrestrial experiments, the system designer can select the proven advanced system features that are appropriate for any particular extraterrestrial application.

ULTIMATE CELL LIFE

The ultimate life of PEM fuel cells and electrolyzers, based on fluoride loss rate, assumes that the cell, stack and system designs are configured to prevent premature mechanical failures. With the elimination of mechanically induced failure, the fluoride loss rate has been found to be an excellent measure of the health and life expectancy of PEM cells.

The fluoride lost from the PEM cell is actually a degradation product of the perfluorocarbon membrane. It should, therefore, not be surprising to find the fluoride loss/ultimate life relationship. The Figure 1 relationship was primarily based on PEM cells using perfluorocarbon membranes in the 8 to 12 mils thickness range. The Figure suggests that perfluorocarbon membranes of less than 8 mils will have a similar ultimate life with a proportional loss of fluoride. This, of course, will only be verified when a large number of cells containing advanced thin perfluorocarbon membranes have accumulated substantial lifetimes.

The fluoride loss rate determination for non-evaporatively cooled PEM fuel cells can be directly measured in the liquid product water. Fluoride detection at the low ppb range can be made directly, while detection at the ppt range is accomplished by concentration techniques. To put the Figure 1 curve into everyday calibration, the following PEM fuel cell example is offered:

Cell Characteristics

Membrane Thickness - 10 mils

Current Density - 500 Amps per Square Foot (ASF)

Life Prediction Vs. Fluoride in Product H₂O

1,000 hours - 2 ppm
10,000 hours - 200 ppb
100,000 hours - 20 ppb

The fluoride loss rate determination for liquid anode feed PEM electrolyzers can be directly measured in the open loop "proton" water. The following PEM electrolyzer example is offered:

Cell Characteristics

Membrane Thickness - 10 mils
Current Density - 1000 ASF

Life Prediction Vs. Fluoride in Proton H₂O

1,000 hours - 140 ppb
10,000 hours - 14 ppb
100,000 hours - 1.4 ppb

Since long life of PEM cells has been inversely equated with fluoride loss rate, the designer can quickly determine the suitability of a given configuration for a particular application. Each manufacturer of PEM cells undoubtedly has his own proprietary techniques for the control of fluoride release rate.

SPE fuel cell and electrolyzer designers incorporate proprietary features into system configurations for extended life. One such demonstration SPE cell is within seven months of reaching 100,000 hours of high current density operation. Figure 2 displays this cell as it passed the ten year mark in May 1988. Two additional SPE test cells have accumulated over ten years of "uninterrupted" operation since the May 1988 milestone.

CELL VOLTAGE STABILITY

The voltage stability of PEM fuel cells and electrolyzers is a second very important feature for many applications. Experience has shown that features that provide a long cell life, as indicated by low fluoride release rates, do not necessarily equate long cell life with stable voltage. This is indeed unfortunate, as it makes it next to impossible to predict the long term voltage stability of a cell design from short-term tests.

In earlier SPE cell designs a reasonable voltage-change rate would unexpectedly turn to a high voltage-change rate. When unpredicted mechanisms were identified and corrective measures taken, the level and longevity of voltage stability improved. As one might imagine, the test, analysis, corrective action and retest cycles have taken many years to obtain the current level of voltage stability.

Figure 3 shows the voltage stability, as measured by voltage-change with time, of six SPE test units. The baseline configuration for SPE electrolyzers and SPE fuel cells is represented by SPE electrolyzer C and SPE fuel cell E. Both of these units have a voltage-change rate of 1 microvolt/cell hour at 1000 ASF and 500 ASF, respectively.

SPE electrolyzers A and B purposely deviate from the baseline configuration for application specific reasons. Both of these units represent a voltage-change rate of 7 microvolts/cell hour. This voltage-change rate is perfectly acceptable for the intended applications (i.e., electric utility hydrogen generation and nuclear submarine oxygen generation).

Like the SPE fuel cell baseline E, SPE fuel cell D displayed a voltage-change rate of 1 microvolt/cell hour. The unit D configuration, formally considered the SPE fuel cell baseline, is limited in current density. SPE fuel cell F had a voltage-change rate of 6 microvolts/cell hour and represents an earlier configuration which was part of the development data base leading to the present SPE fuel cell baseline.

The configurations of the baseline SPE electrolyzer and SPE fuel cell consist of a combination of patented and proprietary features. Each PEM electrolyzer and PEM fuel cell manufacturer will have their own features which, like the SPE devices, will have to be verified by the life test process.

EXTRATERRESTRIAL APPLICATIONS

Many of the future extraterrestrial applications for hydrogen-oxygen fuel cells and electrolyzers involve combining the two devices to produce the equivalent of a battery for electrical energy storage (see Figure 4). The so called regenerative fuel cell has the distinct advantage over traditional batteries in that power and energy are separated. One needs only to increase reactant storage, without increasing the reactor stack(s), to increase the stored energy. The results of this distinction is that the mass advantage of typical advanced batteries lose out to regenerative fuel cells when the discharge time is increased beyond a few tens-of-minutes.

Energy storage system sizing has been examined for a variety of extraterrestrial applications. The most favorable application of the hydrogen-oxygen regenerative fuel cell is the lunar base application because of the long charge/discharge time span. The studies have indicated the next best available energy storage technology (NaS battery) is more than ten times as massive as the hydrogen-oxygen regenerative fuel cell system.

The state-of-the-art of the hydrogen-oxygen regenerative fuel cell is not without disadvantages. Even considering the demonstrated lifetime and voltage stability of the SPE devices, the questions of efficiency and complexity must be considered.

The energy-out-to-energy-in ratio range generally accepted for state-of-the-art hydrogen-oxygen regenerative fuel cells is 55% to 65%. Advanced batteries operating at 75% energy storage efficiency or greater have the clear advantage in this characteristic. The primary reason for the lower hydrogen-oxygen regenerative fuel cell energy storage efficiency is related to electrode performance. Years of research have been invested to improve low-temperature electrode performance with only minor increases observed. Without a breakthrough in low-temperature electrode performance, the lower efficiency of the state-of-the-art low-temperature hydrogen-oxygen regenerative fuel cell is fundamental.

The efficiency of the hydrogen-oxygen regenerative fuel cell results in a greater energy input requirement for a fixed output when compared to advanced batteries. In the case of a photovoltaic power source, this means an increase in the size of the solar array. However, as charge times increase this differential mass becomes insignificant. An order-of-magnitude lower mass for the overall lunar base power system based on the hydrogen-oxygen regenerative fuel cell, as compared to advanced batteries, is still projected even when including the state-of-the-art photovoltaics.

Although the efficiency disadvantage of the hydrogen-oxygen regenerative fuel cell turns out to be insignificant in most extraterrestrial applications, the complexity of state-of-the-art regenerative fuel cells is much greater than most advanced batteries. The very feature that gives the hydrogen-oxygen regenerative fuel cell its significant mass advantage is responsible for its complexity. The complexity arises primarily due to the storage of reactants and products external to the reactors. These state-of-the-art complexities in hydrogen-oxygen regenerative fuel cells include:

- Fuel cell product water removal from the reactant chamber by dynamic reactant recirculation.
- Dynamic separation of the fuel cell product water from the reactant.
- Pumping electrolysis process water up to gas generation pressure.
- Temperature-controlled fluid recirculation in both fuel cells and electrolyzers.
- Separate dedicated fuel cells and electrolyzers.

In total, the state-of-the-art hydrogen-oxygen regenerative fuel cell system would use in the range of 4 to 6 rotating devices, not including redundancy, to provide fluid transport and/or phase separation. Additionally, on the order of twice as many individual cells would be required as would be needed for advanced batteries, simply because the batteries operate both in charge and discharge modes. The complexity, in terms of dynamic components and the large piece-part count, with double the number of cells, relegates the state-of-the-art hydrogen-oxygen regenerative fuel cell to a lower reliability than the more massive batteries.

The reliability of the hydrogen-oxygen regenerative fuel cell can be increased by component redundancies. This approach diminishes the mass advantage and adds to the system complexity. Our approach, of a unitized (reversible) hydrogen-oxygen regenerative fuel cell with static fluid and thermal control features, can improve reliability and reduce complexity, which further improves the mass advantage over advanced batteries.

SYSTEM SIMPLIFICATIONS

With complexity and lower reliability identified as the major concerns in hydrogen-oxygen regenerative fuel cells, manufacturers have begun to respond with a variety of approaches. In particular, SPE fuel cell and SPE electrolyzer designs are being directed toward reduced complexity. Specific developments include:

- Reversible SPE cell
- Passive fuel cell product water separation and removal
- Passive electrolyzer process water introduction
- Passive electrochemical gas pumping
- Passive heat management

Separate dedicated SPE fuel cells and SPE electrolyzers came into favor several years ago due to higher overall energy storage efficiency. It is true that in reversible SPE cells, the preferred SPE fuel cell catalyst results in poor electrolyzer performance and the preferred SPE electrolyzer catalyst results in poor SPE fuel cell performance. Compromise catalyst systems have been developed which bring the overall energy storage efficiency within 5% of the dedicated configuration. Figure 5 shows performance curves for these various configurations.

A specific application may find the 5% efficiency reduction as an acceptable trade for simplicity and mass reduction. Alternately, if the application dictates, by trade study, that discharge efficiency is of prime importance, a 10% energy storage efficiency reduction may be preferred while using optimized fuel cell catalyst.

Passive fuel cell product water separation and removal from the reactor stack in microgravity is certainly not a new idea. Both the Gemini and Biosatellite SPE fuel cells operated with passive wicking product water systems. These systems, however, operated only at low current densities with higher mass and volume structures.

Recent developments in passive water separation and removal from SPE fuel cells have involved separation of the liquid product water from the gaseous oxygen within the cell structure (Ref. 3). This approach, shown in Figure 6, eliminates the need for wicking and uses a hydrophilic separator plate in the oxygen cavity. Testing of this configuration has been very successful to date with operation demonstrated against gravity (i.e., product water separated upward from the cathode electrode). Figure 7 displays the performance of an SPE fuel cell with the passive product water removal feature operating against gravity.

The passive water vapor feed SPE electrolyzer developed during the seventies used a hydrated ion-exchange membrane to feed water vapor to the operating cell. This cell structure (shown in Figure 8) eliminated the need for separating liquid water from the products. However, close control of the water pressure was required. If the water pressure was significantly higher than hydrogen pressure, water hydraulically passed through the water feed barrier and exceeded the electrolysis rate. Conversely, if the water pressure was below the hydrogen pressure, an accumulation of hydrogen in the water feed chamber by normal diffusion resulted in water starvation.

Recently, an innovative feature has been incorporated into the passive water vapor feed SPE electrolyzer. This feature allows the water pressure to be well below hydrogen pressure without the concern of hydrogen buildup in the water feed chamber. The feature consists of electrifying the water feed membrane in order for it to function as an electrochemical hydrogen pump (Ref. 4). Figure 9 shows the electrification of the water feed membrane. The fraction of a watt required for each cell is considered a small penalty to pay for the elimination of the requirements for pumping water up to pressure and maintaining close pressure control.

The electrochemical hydrogen pump allows the water to be fed to the cell at any source pressure down to the cell water vapor pressure without any mechanical pumping. Figure 10 shows the water vapor feed SPE electrolyzer performance with water pressure 160 psi below hydrogen generation pressure.

Several thousand cell hours have now been accumulated on electrolyzer cells supported by the use of electrochemical hydrogen pumps.

The simplifying features described herein have all demonstrated successful operation in ground testing. Although passive fluid phase separation was successfully used in the Gemini and Biosatellite SPE fuel cell systems, none of the described simplifying features have actually flown in space.

THE FLIGHT EXPERIMENT

The planned unitized regenerative SPE fuel cell experiment makes use of the proven life and voltage stability features as well as the simplifying aspects. A basic fluid schematic of the flight experiment is shown in Figure 11. This figure shows one of several experiment options studied. If selected, the experiment will fly on a future Shuttle mission in a simulated low earth orbit energy storage configuration. The potential one week experiment should be of ample length to assess the performance of the various system simplification aspects.

During the experiment discharge cycle, hydrogen gas and oxygen gas are delivered to the reversible cell on a purely demand basis. The reversible cell converts these reactants into dc power with a current output of approximately 100 ASF. The product water, formed within the oxygen chamber as a liquid, contacts the porous plate. The spring bellows in the oxygen/water storage tank creates a pressure differential across the porous plate ($O_2 > H_2O$) of about 1 psi. The 1 psi is more than sufficient to force the product water through the hydrophilic porous plate at the generation rate, but, not nearly high enough to allow passage of oxygen gas.

The product water will be saturated with oxygen, and some small bubbles of oxygen gas will appear as the water pressure decreases by 1 psi as it passes through the porous plate; some oxygen will come out of solution. As this water passes through the water chamber of the water vapor feed barrier membrane, the oxygen gas and dissolved oxygen are converted to water at the positive electrode of the hydrogen pump. This oxygen is chemically consumed by combining with the diffusing hydrogen that otherwise is electrochemically pumped back to the hydrogen chamber. The water eventually delivered to storage is essentially free of dissolved gases. This is an important feature as the system pressures alternate up and down through the charge/discharge cycles.

At the end of the discharge period the pressures in the reactant storage tanks are at the reduced level and a load contactor is opened. This is followed by closing a power contactor to supply charge power to the reversible cell.

In the electrolysis charge mode, water vapor is fed to the operating electrolysis cell across the hydrogen compartment gap. Hydrogen and oxygen gases are delivered to their respective tankage and the system pressures rise. An accumulation of water in the reactant storage tankage is prevented by thermally matching the tankage with the operating cell and the fact that the produced gases are in fact subsaturated.

The electrochemical hydrogen pump milliwatt power draw continues through both the charge and discharge modes. This assures that hydrogen gas does not block the flow of water, and it also provides an actual measure of the amount of oxygen consumed during the discharge water desaturation step.

The entire experiment will be cold-plate mounted. Heat generated within the cell hardware is conducted to the base plate. Figure 12 is a photograph of the experimental hardware mock-up.

SUMMARY

In summary, a flight experiment is planned for the validation in a microgravity environment of several ground proven simplification features relating to SPE fuel cells and SPE electrolyzers. With a successful experiment these features can be incorporated into the designs of equipment for specific extraterrestrial energy storage applications.

REFERENCES

1. Appleby, J.: Regenerative Fuel Cells for Space Applications. Journal of Power Sources, 22 (1988) p.p. 337-385.
2. NASA Conference Publication 3016: September 12-13, 1988 p.p. 206
3. Leonida, A: Hydrogen/Oxygen Fuel Cells with In-Situ Product Water Removal. 33rd International Power Sources Symposium, June 13-16, 1988
4. Sedlak, J; Austin, F.; and LaConti, A: Hydrogen Recovery and Purification Using the Solid Polymer Electrolyte Electrolysis Cell. International Journal of Hydrogen Energy, (1981) Volume 6, p.p. 45-51

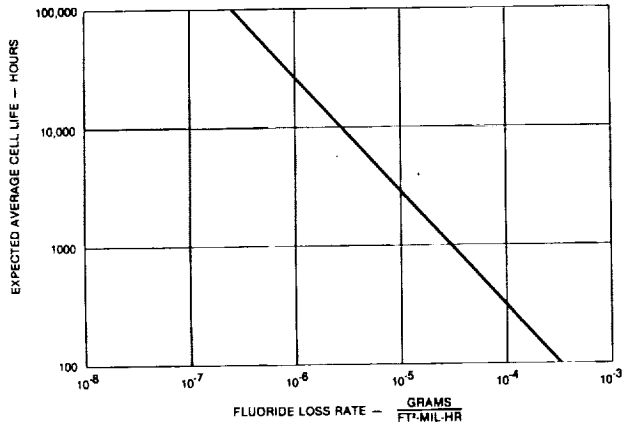

FIGURE 1. EXPECTED LIFETIMES OF SPE CELLS WITH PERFLUOROCARBON PROTON EXCHANGE MEMBRANES

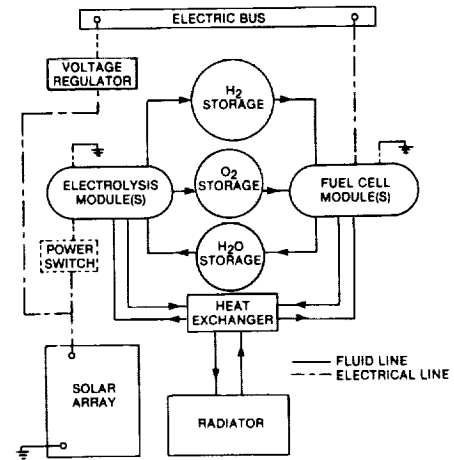

FIGURE 4. HYDROGEN-OXYGEN REGENERATIVE FUEL CELL ENERGY STORAGE SYSTEM

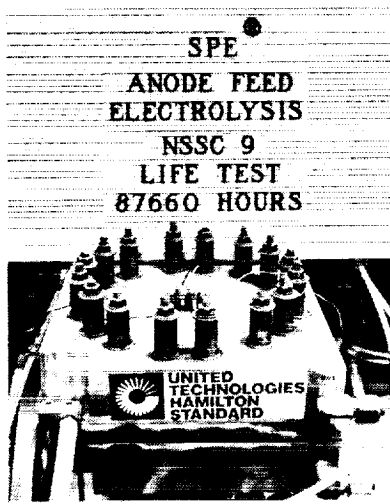

FIGURE 2. "UNINTERRUPTED" SPE ELECTROLYZER LIFE TEST

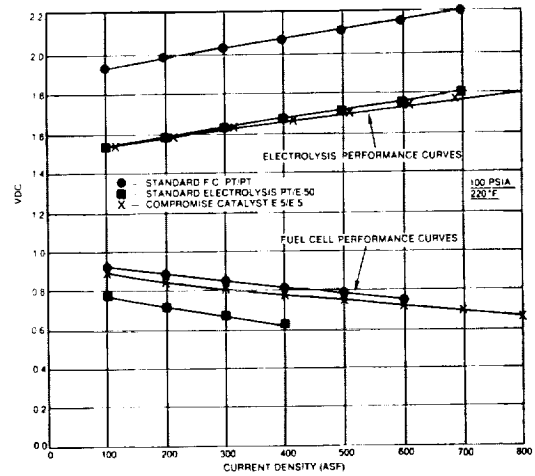

FIGURE 5. COMPARISON OF PERFORMANCE DURING FUEL CELL AND ELECTROLYSIS MODES

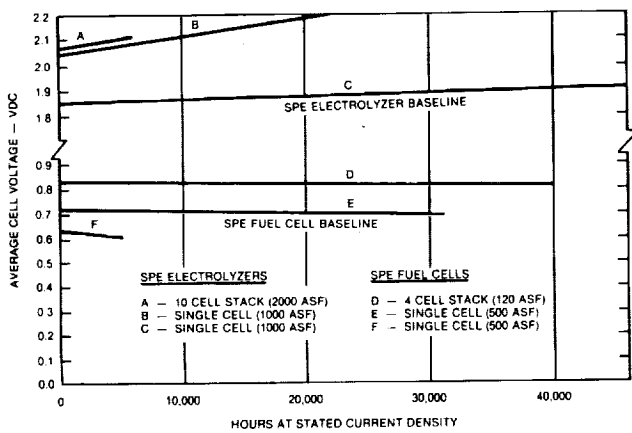

FIGURE 3. SPE CELL VOLTAGE STABILITY

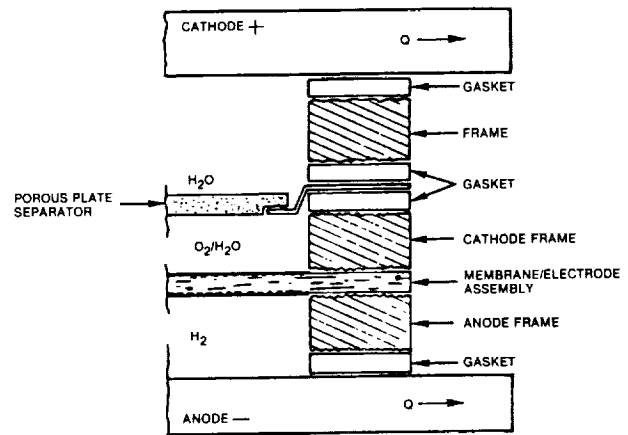

FIGURE 6. PASSIVE STATIC WATER REMOVAL SPE FUEL CELL - CROSS SECTION

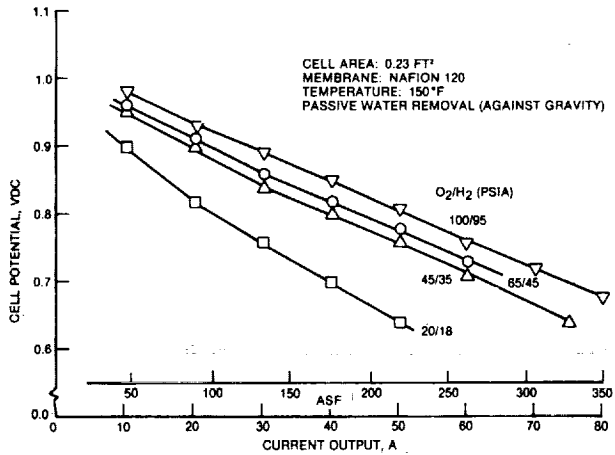

FIGURE 7. PASSIVE WATER REMOVAL SPE FUEL CELL PERFORMANCE AT 150°F

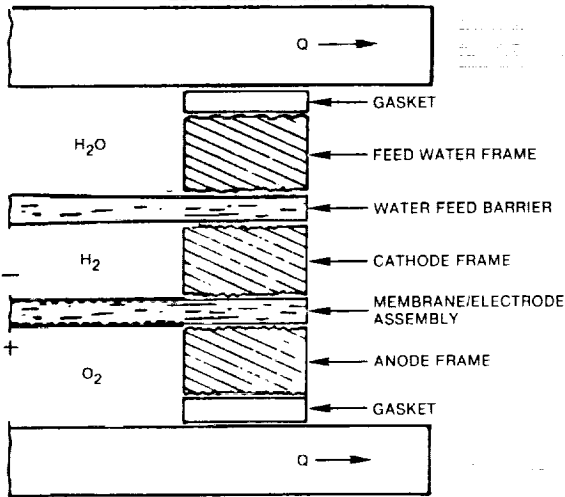

FIGURE 8. WATER VAPOR FEED SPE ELECTROLYZER

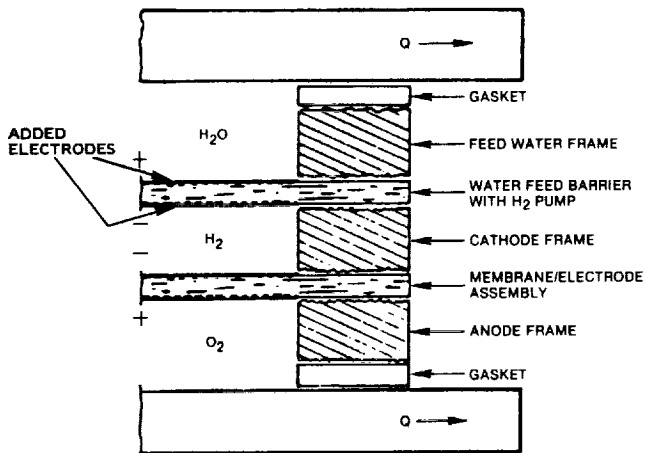

FIGURE 9. WATER VAPOR FEED SPE ELECTROLYZER WITH ELECTROCHEMICAL HYDROGEN PUMP

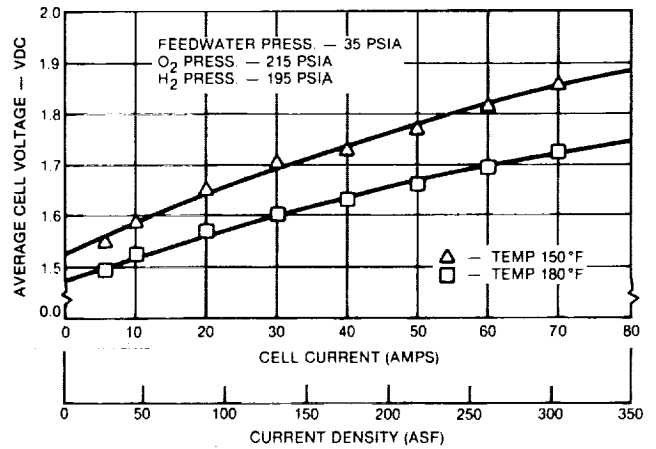

FIGURE 10. WATER VAPOR FEED SPE ELECTROLYZER PERFORMANCE

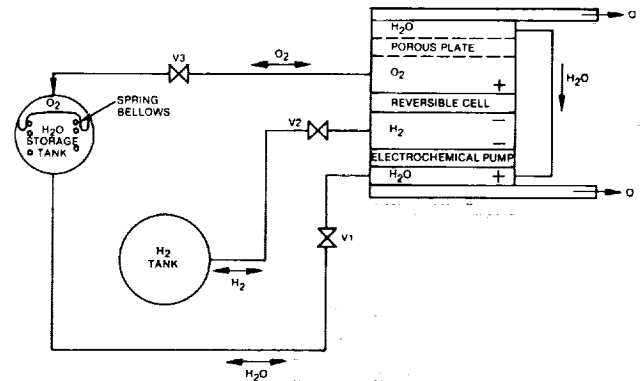

FIGURE 11. UNITIZED REGENERATIVE SPE FUEL CELL

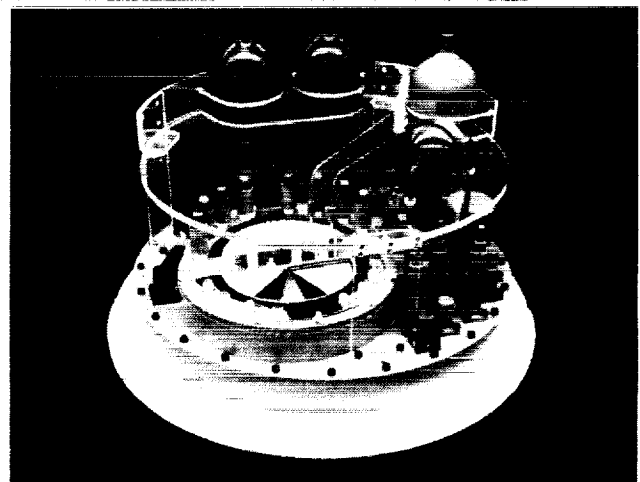

FIGURE 12. UNITIZED REGENERATIVE SPE FUEL CELL MOCK-UP