

N90-21905-72341  
19  
February 15, 1990

TDA Progress Report 42-100

# An 8.4-GHz Dual-Maser Front-End System for Parkes Reimplementation

D. L. Trowbridge, J. R. Loreman, T. J. Brunzie, and R. Quinn  
Radio Frequency and Microwave Subsystems Section

*An 8.4-GHz front-end system consisting of a feedhorn, a waveguide feed assembly, dual masers, and downconverters was reimplemented at Parkes as part of the Parkes Canberra Telemetry Array for the Voyager Neptune encounter. The front-end system was originally assembled by the European Space Agency and installed on the Parkes antenna for the Giotto project. It was also used on a time-sharing basis by the Deep Space Network as part of the Parkes Canberra Telemetry Array to enhance the data return from the Voyager Uranus encounter. At the conclusion of these projects in 1986, part of the system was then shipped to JPL on loan for reimplementation at Parkes for the Voyager Neptune encounter. New design and implementation required to make the system operable at Parkes included new microwave front-end control cabinets, closed-cycle refrigeration monitor system, noise-adding radiometer system, front-end controller assembly, X81 local oscillator multiplier, and refurbishment of the original dual 8.4-GHz traveling-wave masers and waveguide feed system. The front-end system met all requirements during the encounter and was disassembled in October 1989 and returned to JPL.*

## I. Introduction

The front-end system was originally assembled by the European Space Agency (ESA) for installation on the Parkes antenna in support of the Giotto project. The radio frequency (RF) package, containing a waveguide feed system, dual traveling-wave maser and closed-cycle refrigerator assemblies (TWM/CCRs), and the TWM monitor and control instrumentation, was built by the Airborne Instrument Laboratories (AIL) division of Eaton Corporation. JPL provided AIL with the waveguide feed system, the TWM design based on the JPL Block II-A TWM [1], the TWM monitor and control instrumentation design, and technical consulting during the manufacturing and testing of the system. As a result of an agreement between

NASA/JPL and ESA, the front-end system was also used on a time-sharing basis by the Deep Space Network (DSN) as part of the Parkes Canberra Telemetry Array (PCTA) to enhance the data return from Voyager 2 at Uranus. At the conclusion of these projects in 1986, the front-end system was dismantled, packed, and shipped to Europe. Part of the system was then shipped from ESA to JPL on loan for reimplementation at Parkes for the Voyager Neptune encounter.

New design and implementation tasks required to make the system operable at Parkes for the Voyager Neptune encounter included new microwave front-end control cabinets, CCR monitor system, noise-adding radiometer

(NAR), front-end controller (FEC), X81 local oscillator multiplier, and refurbishment of the original dual 8.4-GHz TWMs and waveguide feed system.

During the Voyager Neptune encounter, Canberra Deep Space Communications Complex (CDSCC) personnel were responsible for the maintenance and operation of the Parkes antenna front-end microwave electronics. A decision was made not to replicate the ESA-designed monitor and control system, and a new system was built around an Intel Multibus computer similar to that used in the Parkes/CDSCC Telemetry Array (PCTA) equipment. Advantages of this approach included automated operation at the PCTA Parkes site, the availability of health and status information (and to some extent, control) at the Canberra site (SPC-40), and the ability to share common spares with PCTA equipment.

In addition to the front-end monitor and control functions, an NAR function was added to the system. Intended primarily to aid antenna pointing calibration procedures, the NAR was capable of monitoring system-noise temperature during either pre-pass or (in an optional mode) telemetry tracks.

The front-end system met all requirements during the encounter and was disassembled in October 1989 and returned to JPL.

## II. Reimplementation for Parkes/Neptune

Reimplementation of the front-end system for the Neptune encounter required a substantial amount of design, fabrication, and procurement due to the absence of some key hardware components. Specifically, all Hewlett-Packard (HP) commercial equipment had been removed from the 1986 system with the following consequences:

- (1) There was no means of controlling or reading the position of the waveguide switches or polarizer (other than manually).
- (2) There was no means of monitoring the health and status of the CCRs and compressors other than by personal inspection.
- (3) There was no means of monitoring the health and status of the downconverters, monitor receiver, or upconverter other than by personal inspection.
- (4) There was no automation of system configuration or calibration.

Some consideration was given to purchasing all the missing hardware and software so that the system could

be rebuilt and operated exactly as it was in 1986; however, this idea was abandoned due to financial and practical considerations.

A number of fundamental constraints applied to this reimplementation task:

- (1) The equipment supplied by ESA was on loan to JPL and any modifications made to the equipment required prior approval from ESA or had to be reversible prior to returning the equipment to ESA.
- (2) There were a limited number of cables available through the wrap on the Parkes antenna so any new design was ideally to use no more cables.
- (3) The physical space for new equipment was limited and was not to exceed that used in 1986, if possible.
- (4) Equipment weight in the aerial cabin needed to be minimized to avoid damage to the focus drive gear. The total weight in 1986 was considered excessive.
- (5) There was no plenum air conditioning available in the aerial cabin or in the NASA trailer; however, a limited amount of room air conditioning was available.
- (6) Remote monitor and control of many parameters was mandatory because of the normally inaccessible location of the front end (at prime focus), and the fact that the equipment was unmanned during much of the pre-encounter period.
- (7) The usual constraints of operability, reliability, and maintainability also applied.

The preliminary system design has been previously reported [2].

## III. Parkes Front-End System

### A. General Description

The configuration of the front-end system, described below, is similar to that for the 1986 encounter, with the exception of pre-/post-TWM signal-coupling ports provided for the Commonwealth Science Industrial Research Organization (CSIRO) of Australia, who operate and maintain the Parkes antenna, and two new local oscillator frequency-multiplier chains (X81) that drive the two RF-IF (intermediate frequency) downconverters.

The front-end system configuration, shown in Fig. 1, consisted of the following:

- (1) Aerial cabin equipment, which included the feed and all microwave components, traveling-wave maser low-noise amplifiers and their closed-cycle refrigerators, downconverters, an upconverter, test-signal switching, noise-diode assemblies, and a monitor receiver.
- (2) NASA trailer control room equipment, which included all maser controls, switching and all monitor and control for the front-end system.
- (3) Antenna pedestal equipment, which consisted of the helium compressors for the CCRs, and an FEC remote terminal which supported antenna pointing calibrations.

## B. Aerial Cabin Equipment

The RF package, shown in Figs. 2 and 3, contained the feed system and the dual-maser amplifiers. Three aerial cabin racks, A, B, and C (Fig. 4), contained the balance of front-end RF and TWM/CCR monitor and control equipment. This equipment must be in close proximity to the TWM/CCRs and waveguide feed system, and would require excessive cables to relocate the equipment. The total weight of the front-end equipment, including the RF package installed in the aerial cabin, was 630 kilograms.

A block diagram of the aerial cabin RF equipment is shown in Fig. 5. The feedhorn assembly was located at the primary focus of the antenna and was connected to a rotatable polarizer and orthomode transducer. The system provided two identical receive channels for redundancy, using TWMs based on the JPL Block II-A TWMs and operating at 8425 MHz (nominal) with 100-MHz bandwidth. Down-conversion to 325 MHz (nominal) was accomplished with two identical downconverters, using fixed-frequency local oscillators at 8100 MHz phase-locked to the station 100-MHz timing. Either one of the 325-MHz downconverter outputs could be selected as the input to the short-loop telemetry receiver (not part of the front-end system).

A single monitor receiver with switchable input was provided for monitoring maser gain bandwidth response. The X-band input signal to the monitor receiver was obtained from couplers located in each of the downconverters. The local oscillator for the monitor receiver was also obtained from the downconverters, and hence the monitor receiver input switching selected an X-band input signal and local oscillator as a pair. Output was at 325 MHz (nominal).

The test-signal injection system consisted of a programmable synthesizer operating at 425 MHz (nominal), an upconverter known as the X-band test generator, and a test-signal switching and distribution network that allowed selection of the test signal to either maser input or output.

The synthesizer output could be phase modulated with high-rate data from an external source and was coherent with station timing. Upconversion to 8425 MHz was accomplished with an 8000-MHz fixed-frequency local oscillator, which was also coherent with station timing. A wideband output (for maser bandpass measurement) and a narrowband output (for telemetry testing) was provided on the upconverter.

The switching network consisted of a monitor/test-signal assembly and two TWM calibration assemblies based on JPL designs.

## C. NASA Trailer Control Room

Two new RF front-end control (RF FEC) cabinets were installed in the NASA trailer. These cabinets are shown in Fig. 6 and a control flow diagram is shown in Fig. 7. The two new cabinets required new multi-conductor cables between the antenna pedestal control room and the NASA trailer. The two RF FEC cabinets were the maintenance points for tuning and adjusting the dual TWMs. The cabinets contained the monitor receiver display (an HP Spectrum Analyzer 8590A), the 420-MHz nominal test-signal source (an HP Synthesizer Signal Generator 8663A), the front-end controller including a local terminal, the CCR monitor system, and the TWM monitor and control equipment.

## D. Detailed Functional Descriptions

1. **Front-end controller.** Reimplementation of the Parkes antenna front-end system centralized and automated the monitor and control of the microwave electronics. This monitor and control was provided by the front-end controller (FEC) assembly, a multibus-based computer mounted in control cabinet no. 2. The FEC tied together individual pieces of equipment in the trailer, some of which interfaced with hardware located in the antenna aerial cabin.

Control of the FEC was provided through a cathode-ray tube (CRT) terminal located in control cabinet no. 1. A second CRT was located in the antenna pedestal's 3rd floor, dedicated for use during antenna pointing calibration. A third CRT was located at CDSCC SPC-40 and communicated with the FEC through modem and data

link between Parkes and Canberra. All three of these terminals were able to send commands and to monitor front-end status at any time; however, only one terminal at a time could be used as the master terminal. The master terminal was able to lock the front-end configuration for security during actual tracking missions. Selection of the master terminal was through a switch mounted on the front of the FEC chassis. Terminal CRT displays could be printed out on inkjet printers, which provided a permanent record of all data, commands, and informational graphics.

Commands for the FEC were grouped according to function. Each group had a menu (one example is shown in Fig. 8), and one or more status displays. Commands were listed in the menus, along with a brief description of the function of the command. Syntax and range checking were enforced, with individual error statements for each command. Some commands also responded to a query; entering a question mark as a parameter would display the current variable values as a one-line status display.

The FEC provided cabling interfaces with the following front-end monitor and control instrumentation (Figs. 6 and 7):

- (1) IEEE-488 cabling from the FEC central processing unit (CPU) to an HP quartz thermometer, test-signal synthesizer, spectrum analyzer, and power meter, and (through an IEEE-488 extender to the aerial cabin) the noise-diode relay switch controller, the test oscillator upconverter, the ac power controller for the waveguide switches, the monitor receiver, and each of the two downconverters
- (2) Parallel transistor-transistor logic (TTL) control lines from the FEC CPU to the dual TWM control panel
- (3) RS-232 serial communication lines from the FEC serial ports to the following terminals:
  - (a) Communications modem (link with SPC-40 CRT)
  - (b) A local dumb terminal for front-end operation and maintenance
  - (c) A remote dumb terminal in the antenna to support NAR operation during antenna pointing calibration
  - (d) A CCR monitor (described in a following section)

- (4) 50-ohm coaxial cable from the PCTA receiver upconverter drawer to the power meter board in the FEC, and from the FEC to the noise-diode power supplies in the aerial cabin.

Front-end system tasks performed by the FEC included:

- (1) Monitor and control of the RF front-end waveguide switches and polarizer drive assembly via IEEE-488 using an HP 3488A remote switch/control unit with plug-in HP 44471A relay modules for power control and an HP 44474A digital input/output (I/O) module for telltale monitoring showing the true mechanical position of the devices (not provided in 1986). Manual control in the event of hardware failure was possible from the front panel of the HP 3488A in the aerial cabin. The status of these switches could be displayed on the terminal CRTs (see Fig. 9).
- (2) System temperature measurement (see Fig. 10) using the Y-factor technique through automation of the waveguide switches, quartz thermometer, dual TWM control assembly, and HP power meter (see Fig. 11 for output display).
- (3) Measurement and graphical display of TWM 1 and 2 gain versus frequency. The data was stored and could be retrieved as shown in Fig. 12.
- (4) Performance of NAR functions under remote control during antenna calibration via automation of the noise-diode assemblies and the digital power meter. This task included returning a time-varying analog signal to the pedestal, corresponding to measured system temperature, as well as periodic calibration of the noise diodes.
- (5) Providing status updates and charting performance history of the refrigerators and compressors, as requested. This task included generating alarm messages based on CCR out-of-limits conditions provided to the FEC by the CCR monitor.
- (6) Detection of alarms from the downconverters, monitor receiver, and test-signal upconverter. These included power supplies, local oscillator power levels, timing, and phase-lock conditions.

**2. Noise-adding radiometer.** Noise-adding radiometers (NARs) operate by periodically injecting small, known quantities of noise into the antenna front end, then measuring the resulting increase in system-noise power at the receiver. For the Parkes implementation, this additive noise was generated using a DSN noise-diode assembly; the power meter in the front-end controller performed

the noise-power measurements. During antenna-pointing NAR operations, system temperature calculations were carried out continually, with the FEC supplying a corresponding analog voltage to the antenna pedestal via a digital-to-analog (D/A) converter.

Two noise-diode assemblies were supplied for the Parkes antenna, one for each of the two X-band receive chains. Each assembly consisted of a noise-diode oven and associated power supply. Each oven contained three diodes, providing noise temperatures of 0.25 K, 0.5 K, 1 K, 2 K, 4 K, 8 K, and 50 K. The ovens were controlled through their power supply assemblies, each of which contained three independent power supplies, one for each diode. Three relays per supply were used to select the amount of diode current (allowing three noise levels per diode), while a fourth TTL signal modulated the diode on and off. Each power supply assembly was monitored and controlled through 21 digital I/O lines, consisting of relay closures, telltale sense, and diode-modulation input. Both assemblies were operated through an HP 3488A remote switch controller containing three HP 44474A digital I/O cards (16 channels per card); coaxial cable run directly from the FEC supplied the modulation control signals. Since an identical HP controller was used to operate the waveguide switches, common spares existed for both the switch controllers and the I/O cards.

At the other end of the receive chain, noise-power measurements were taken from the inputs of the Parkes telemetry receiver. Each of the two 285–360-MHz RF signals were split 3 dB in the signal-select drawer, and then one output arm was fed directly into the power meter in the FEC.

The NAR power meter was a DSN precision power meter (PPM) NAR RF assembly, containing an RF switch, a square-law diode, and a voltage-to-frequency converter. The output frequency was counted and averaged within the FEC, using a PPM frequency-counter board.

Diode control, noise measurement, system-temperature computation, and analog output programming were all handled by the FEC CPU, with results included in FEC status displays.

**3. Closed-cycle refrigerator monitor.** The closed-cycle refrigerator (CCR) monitor system consisted of three  $\mu$ MAC 5000<sup>1</sup> data acquisition assemblies and an IBM PC-XT data acquisition unit (DAU), used for data display, processing, and storage [3]. The DAU was located

in front-end control cabinet no. 2 (Fig. 6) located in the NASA trailer. One  $\mu$ MAC was located in the aerial cabin to monitor both CCRs, while the other two  $\mu$ MACs were located in the compressor room in the antenna pedestal (Fig. 13) to monitor one compressor each. Data were sent from the  $\mu$ MACs to the DAU at one-minute intervals.

Communication between the  $\mu$ MACs and the DAU was serial RS-232 and utilized a coaxial cable daisy-chained to all devices. An additional RS-232 port on the DAU provided the interface to the FEC via the serial-communications card.

The DAU was dedicated solely to CCR system-monitor tasks. The DAU continuously displayed CCR and compressor parameters, updating the screen once a minute as data were received from the CCR system. These parameters were also echoed to the FEC, the most up-to-date values being used to generate routine PCTA status displays.

Monitored CCR/compressor parameters included:

- (1) CCR stage temperatures (nominally 4.5 K, 15 K, and 70 K)
- (2) Refrigerator reserve capacity (percentage of normal)
- (3) Helium pressures (supply, refrigeration return, Joule-Thomson return, tank, and oil stack differential)
- (4) Third-stage, i.e., Joule-Thomson helium flow
- (5) Compressor temperatures (first- and second-stage)
- (6) Vacuum pressure in CCR vessel
- (7) Compressor motor phase currents (A, B, C)

In addition to the CCR/compressor parameter values, each record sent by the DAU to the FEC was formatted with status flags indicating whether each value was within acceptable limits. (All CCR/compressor alarm limits were entered at the DAU keyboard.) Any out-of-limit conditions caused the FEC to immediately send a PCTA-compatible alarm message (including audible tone) to each FEC terminal.

In order to track performance history, the DAU time-tagged and logged the CCR/compressor data to its hard disk every 15 minutes. An entire year's worth of data (96 records/day) could be recorded. In addition to the long-term storage in the DAU, the FEC stored data received

<sup>1</sup> Trademark of Analog Devices, Inc.

during the preceding 72 hours (transmitted in one-minute intervals).

This performance history was made available in two forms; for both forms, one or more parameters were displayed in columns upon specification of a start date/time and a stop date/time. Short-term history (up to 72-hours old) had a maximum resolution of one minute; long-term history resolution was 15 minutes. Data records that were not found in the 72 hour FEC short-term cache could be automatically requested from the DAU hard disk log, indexed by day of year, time of day, and CCR/compressor system number.

**4. Alarm monitoring.** The downconverters, monitor receiver, and test-signal upconverter had built-in alarms to detect failures or performance degradation. These alarms were detected by polling the equipment over the IEEE-488, and were monitored by the FEC. Alarm conditions generated a PCTA-compatible alarm message and the condition of all monitored parameters was included in routine FEC status displays.

Alarms monitored included:

(1) Downconverters:

- (a) DC Power: Detects any power supply voltage drops of over 15 percent.
- (b) Phase lock: Detects X-band local oscillator PLL phase-lock.
- (c) 100-MHz standard: Detects low or missing 100-MHz reference from station frequency and timing subsystem (FTS).
- (d) Local Oscillator (LO) Power: Detects low local oscillator power.
- (e) Sum: Reports if any of the above alarms are true.

(2) Upconverter:

- (a) DC Power: Detects any power supply voltage drops of over 15 percent.
- (b) Phase lock: Detects the X-band local oscillator PLL phase-lock.
- (c) 100-MHz standard: Detects low or missing 100-MHz reference from station FTS.
- (d) LO power: Detects low local oscillator power.
- (e) Sum: Reports if any of the above alarms are true.

(3) Monitor Receiver:

- (a) DC Power: Detects any power supply voltage drops of over 15 percent.
- (b) Sum: Reports if any of the above alarms are true.

## IV. Front-End System Refurbishment and TWM Performance

The two TWM/CCRs as received from ESA required some repair and upgrade. Both TWMs were tested when received at JPL; the measured gain/bandwidth performance fell short of Block II-A requirements. The length and thickness of the magnetic field shaping shim sets were modified to meet Block II-A maser 100-MHz 3-dB bandwidth specifications. The final gain/bandwidth performance and maser equivalent input noise-temperature measurements were performed on the two ESA TWMs before and after modifications. The results are shown in Figs. 14, 15, and 16. The performance of the two masers installed on the Parkes antenna is discussed below. The cooling capability of the CCR was verified, and a reserve refrigeration capacity of approximately 2.8 W was recorded for each CCR.

During the refurbishment period, a leaking waveguide vacuum window and faulty internal CCR wiring harness were also replaced. The new harness facilitated the installation of new cryogenic temperature-sensing diodes required by the new CCR monitor.

Due to the conditions under which the system had been previously stored and/or shipped, some corrosion had occurred inside the maser pump assemblies and at some of the waveguide flanges between the feedhorn and the TWM/CCRs. The pump assemblies were cleaned, and those components damaged by corrosion were replaced. New modulator/protect assemblies were installed to upgrade the pump source to meet Block II-A maser requirements. The input waveguide feed components were disassembled, inspected, cleaned, and the flanges lapped flat. To prevent further corrosion caused by moisture entering the feed system, a means of waveguide pressurization was investigated. There is no source of dry gas available in the aerial cabin on the Parkes antenna, so it was necessary to provide a lightweight source of gas that could be used during shipment and after installation on the antenna. Based on the very low leak-rate measurements made at JPL, a device supplying dry air at less than 47.2 cm<sup>3</sup>/min was required. Although the entire front-end assembly was wrapped in plastic sheeting while in shipment,

a commercial desiccant cartridge was enclosed to provide additional protection against moisture. The cartridge was attached to a tube fitting on an unused port of a waveguide switch. Where ac power was available at JPL, Tidbinbilla, and Parkes on the antenna, a Dielectric Communications Model 150 compressor dehydrator was used. This rack-mountable device, weighing 9 kg, was ordered with a special low-pressure option providing for operation at the desired pressure of approximately 0.04 kgs/cm<sup>2</sup>. The dehydrator was mounted in the aerial cabin near the RF front-end assembly.

## V. Front-End System Performance

The front-end system performance (gain, bandwidth, input noise temperature, and gain stability) was measured at JPL prior to shipment, at CDSCC after shipment, and at Parkes after installation on the antenna. The front-end system performance remained within project specifications in each case.

The noise-temperature performance of the RF package (in the absence of an antenna) was measured by attaching a high-quality feedhorn to the waveguide feed input flange (Fig. 3) and then measuring the Y-factor obtained when alternately switching (using the waveguide switch at the input of each maser) between the feedhorn looking at the "cold" sky and an ambient waveguide termination. The system temperature measurements were taken using the FEC to measure Y-factor at the output of the down-converter's 325-MHz IF. The system noise temperature of the front-end at JPL measured 15.4 K using TWM No. 1 and 15.6 K using TWM No. 2. At the CDSCC (Fig. 3), the same measurement resulted in 14.5 K and 15.7 K respectively.

The system was then installed on the Parkes antenna. The system-noise temperature measured 22 K using either maser channel (antenna at zenith, broken clouds). The gain/bandwidth curves measured on TWM 1 and TWM 2 after installation on the Parkes antenna are shown in Fig. 17. The system-noise temperature and maser gain/bandwidth data were within the specified requirements and indicated no change resulting from shipping.

The FEC software, CCR monitor software, and the front-end instrumentation control functions were tested after installation on the Parkes antenna. After some software corrections, all functions were verified to perform correctly, and all design parameters were met or exceeded.

## VI. Conclusion

A PCTA design review for the Parkes front-end system was presented in November of 1987 and the majority of the front-end system requirements were established at that time. A previous TDA Progress Report [2] listed a number of requirements and constraints that affected the design approach selected. Later, frequency stability requirements were established for radio occultation experiments during the Voyager encounter with Neptune, and operational and maintenance requirements were requested by CDSCC engineering staff. The system with the newly designed FEC, NAR, CCR monitor, system alarm monitor, and refurbished RF front-end met all station operation and maintenance, Voyager Project, and radio occultation experiment requirements.

The design of the FEC provided a background of successful hardware and software development for the future design and development of controllers for low-noise amplifiers in the DSN.

## Acknowledgments

The Parkes front-end system refurbishment and reimplementation is the product of the Parkes front-end team members L. Fowler, J. Kovatch, and T. Sweeney, in addition to the authors, who are members of the JPL Microwave Electronics Group, under the supervision of S. Petty. Also, the CDSCC engineering staff, under the direction of M. Dinn, contributed greatly to the success of this project from the design phase through installation, testing, and operation.

## References

- [1] D. L. Trowbridge, "Block IIA Traveling-Wave Maser," *TDA Progress Report 42-87*, vol. July-September 1986, Jet Propulsion Laboratory, Pasadena, California, pp. 158-164, November, 15, 1986.
- [2] D. L. Trowbridge, J. R. Loreman, T. J. Brunzie, and B. Jenkins, "An 8.4-GHz Dual Maser Front-End for Parkes Reimplementation," *TDA Progress Report 42-93*, vol. January-March 1988, Jet Propulsion Laboratory, Pasadena, California, pp. 214-228, May 15, 1988.
- [3] L. Fowler and M. Britcliffe, "Traveling-Wave Maser Closed-Cycle Refrigerator Data Acquisition and Display System," *TDA Progress Report 42-91*, vol. July-September 1987, Jet Propulsion Laboratory, Pasadena, California, pp. 304-311, November 15, 1987.



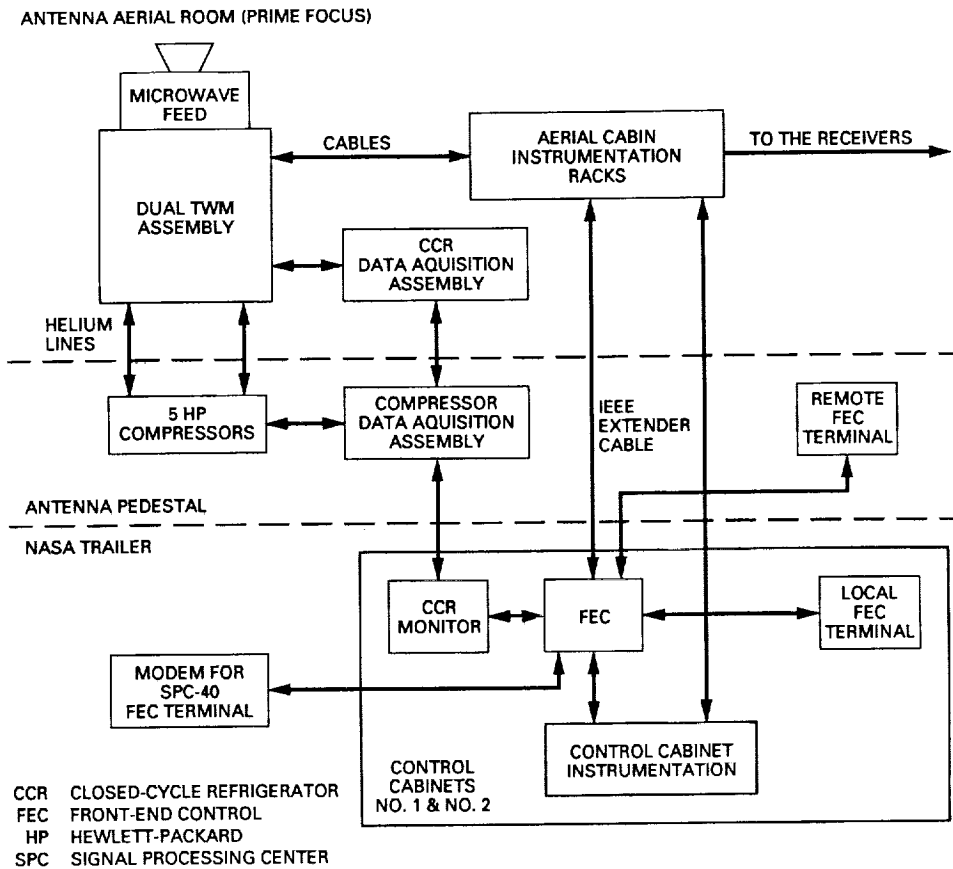
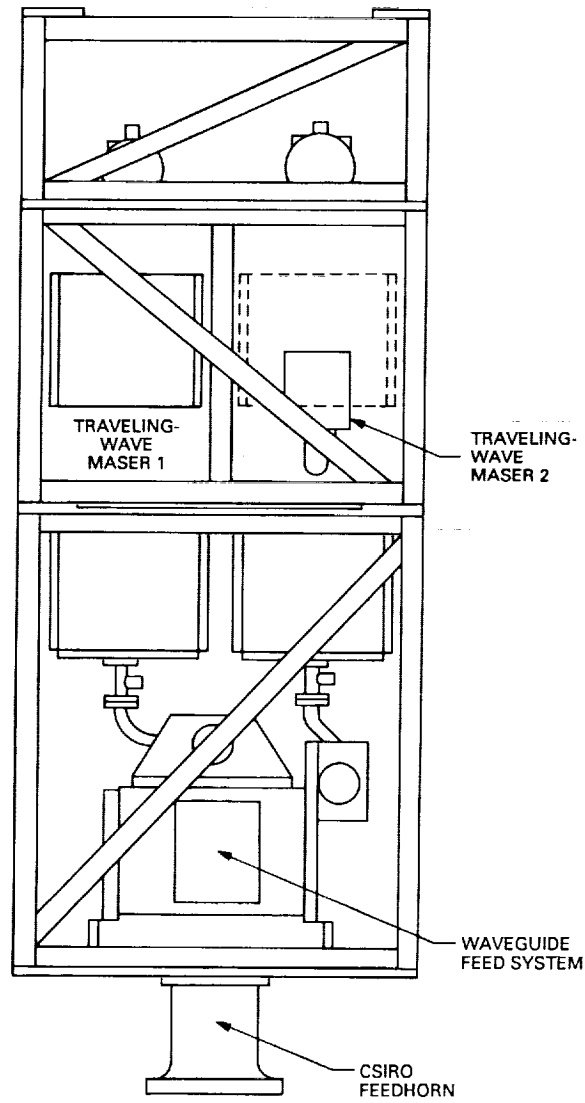

Fig. 1. Parkes front-end system.



**Fig. 2. Parkes RF package.**

ORIGINAL PAGE  
BLACK AND WHITE PHOTOGRAPH

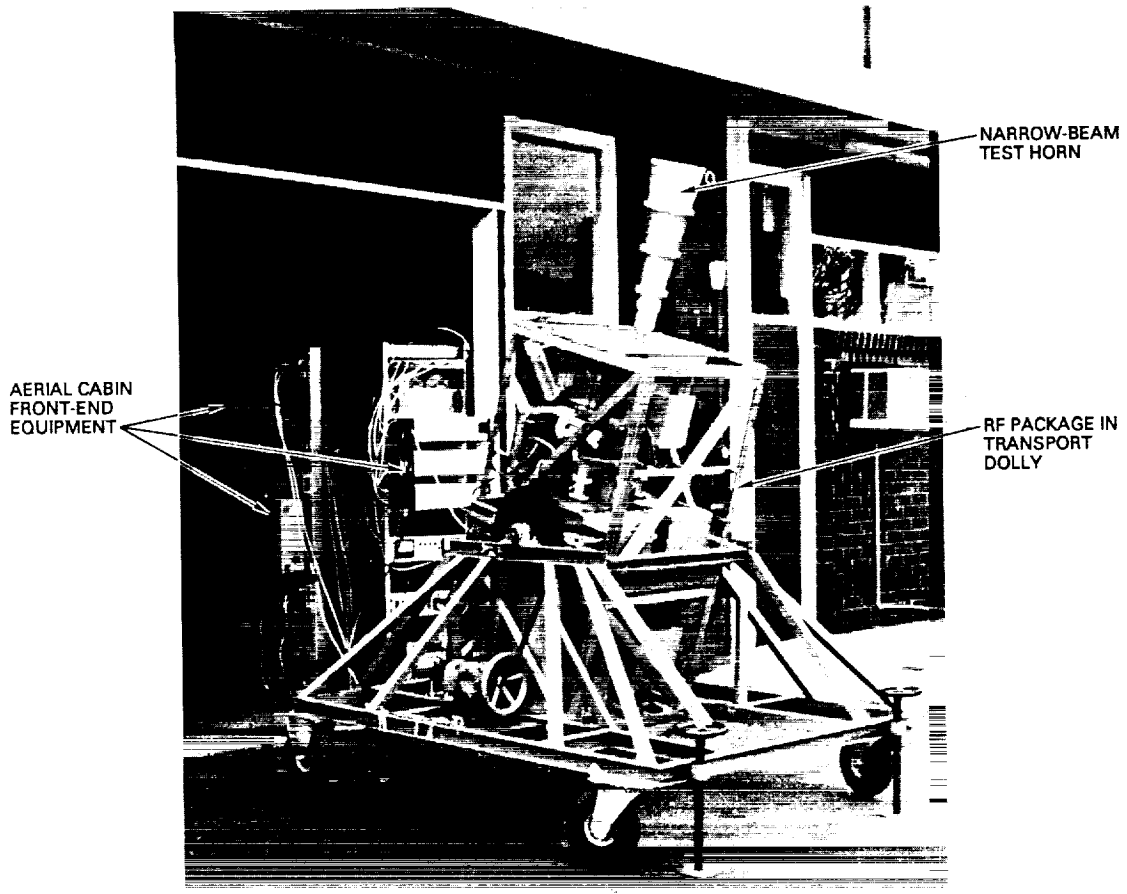

Fig. 3. Parkes front-end system under test.

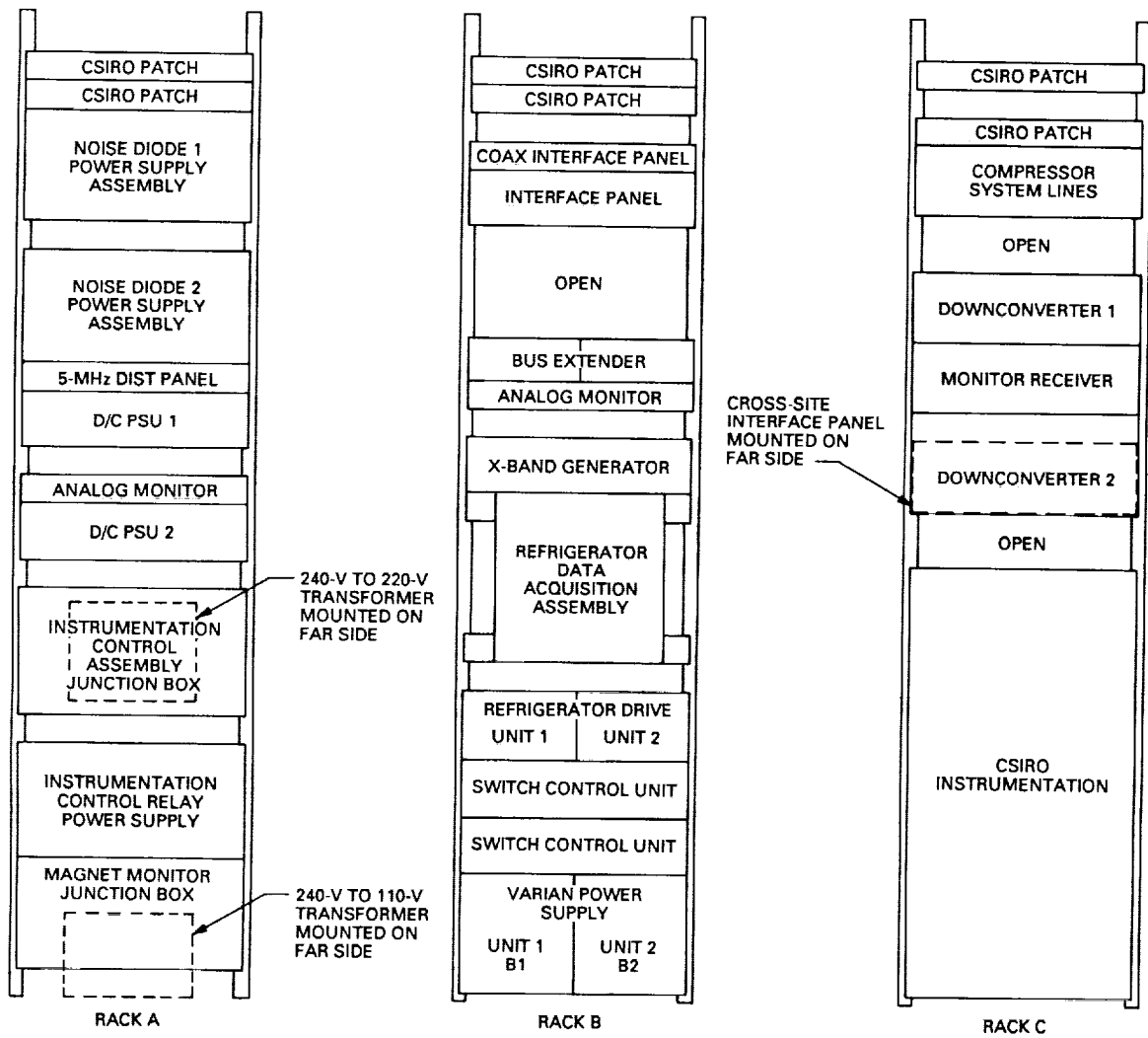

Fig. 4. Aerial cabin racks, 1989.

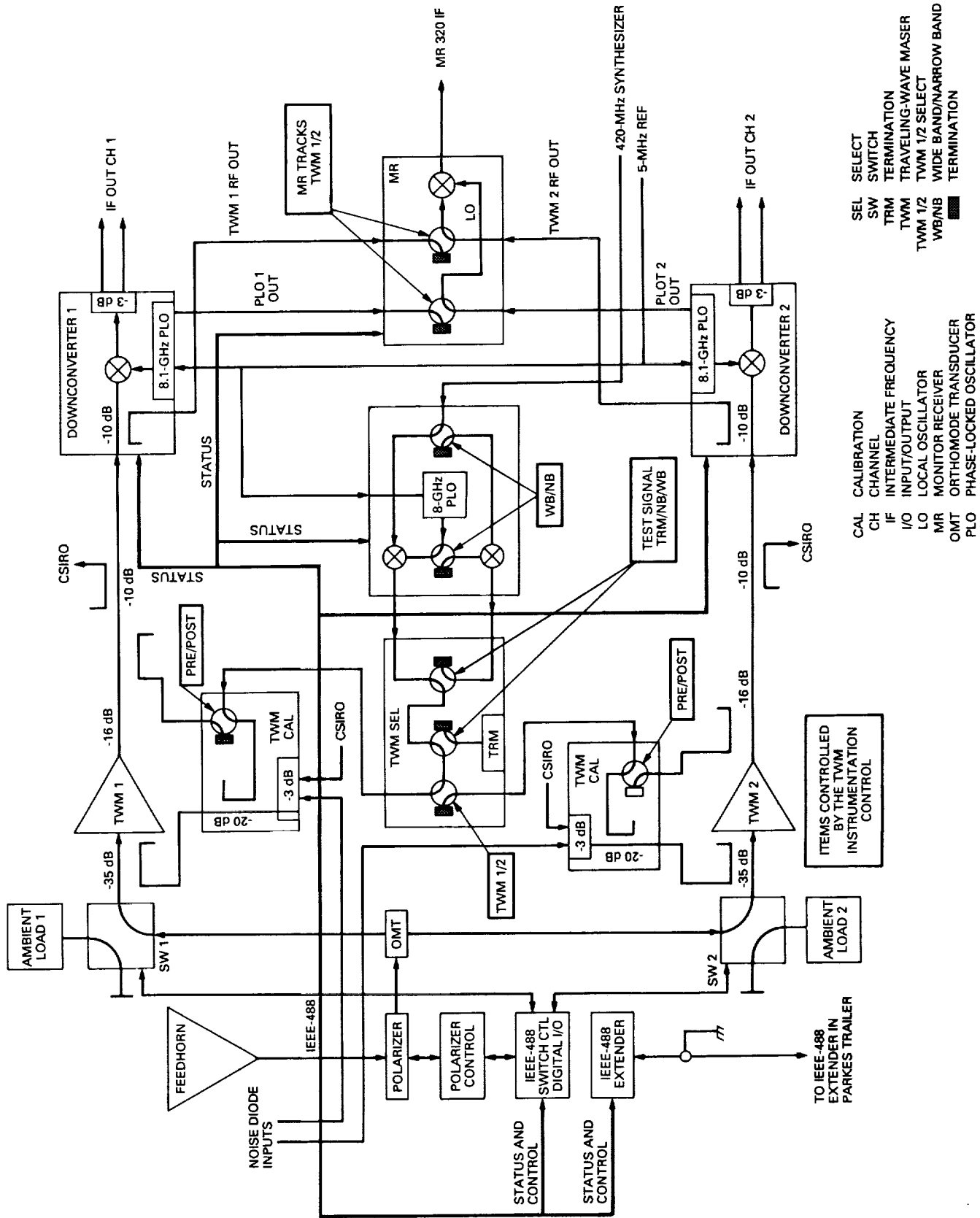
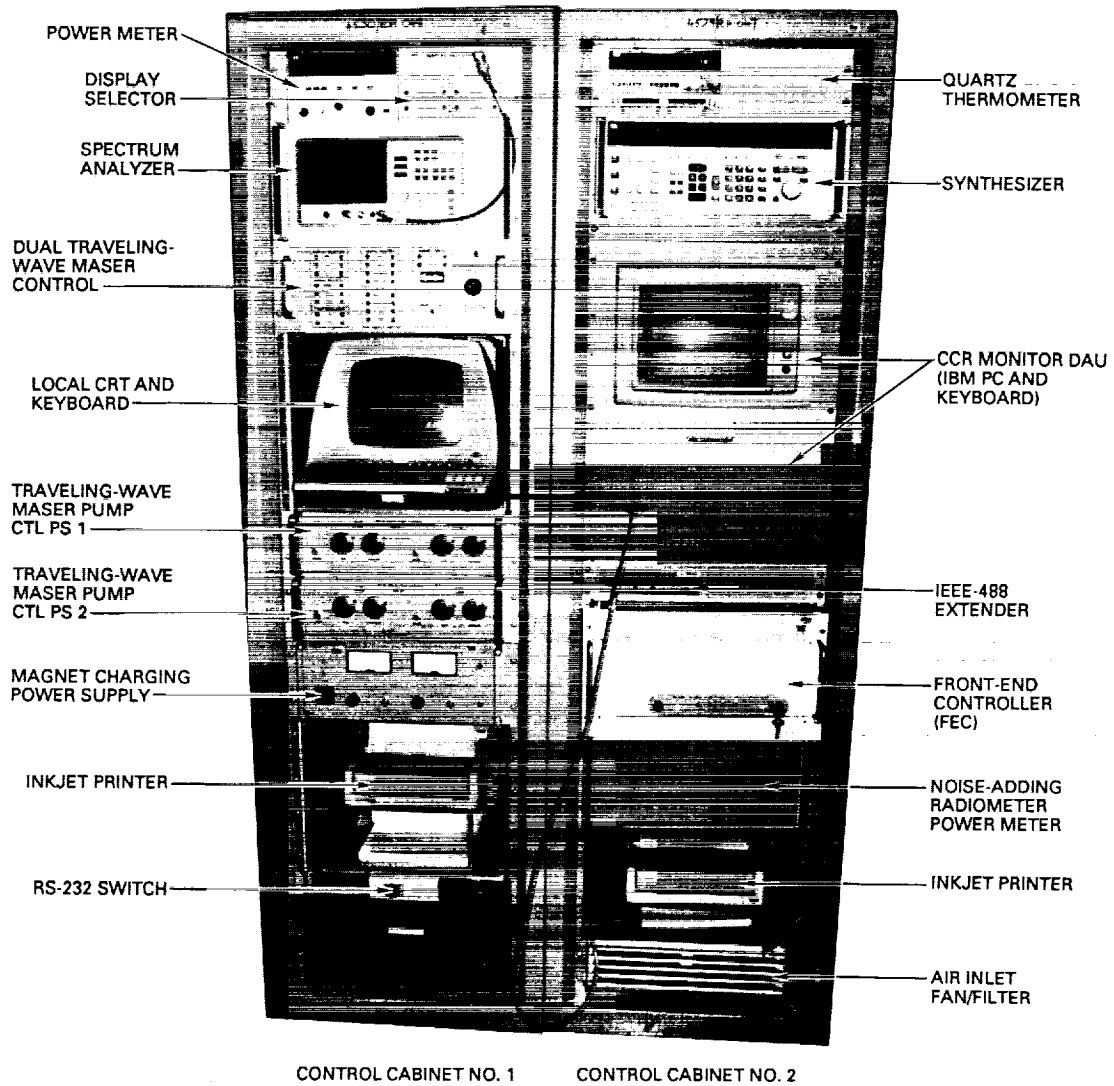

Fig. 5. RF equipment and control flow diagram: aerial cabin.



CONTROL CABINET NO. 1      CONTROL CABINET NO. 2

**Fig. 6. RF front-end control cabinets.**

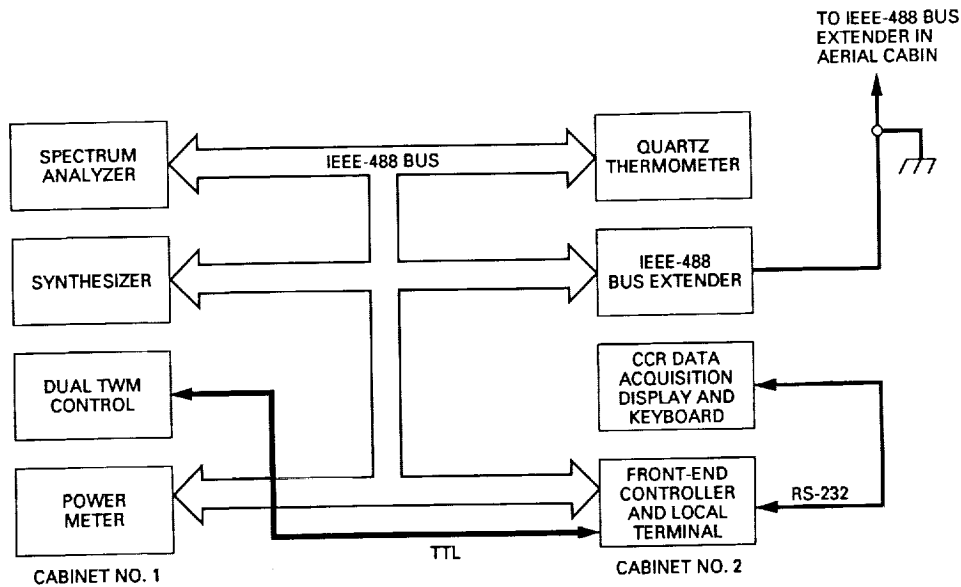

Fig. 7. Control flow diagram: control cabinets.

```

PFEC>help c

PFEC Front End Controller Configuration Help...
The format for user input is: COMMAND PARAMETER

  Cmnd  Description                                     Parameter
  -----
  MINP  Set Maser Input Source.                       [1],[2] [S]ky,[A]mbient Load
  MPOL  Set Maser Input Polarization.                 [1],[2] [L]eft,[R]ight
  TSBW  Set Maser Test Signal Bandwidth.             [W]ide,[N]arrow,[T]erminate
  TFRQ  Set Maser Test Signal Frequency.             [OFF],[n] MHz
  TAMP  Set Maser Test Signal Amplitude.             [OFF],[n] dBm
  TMOD  Set Maser Test Signal Modulation.            [Off],[n] deg
  MRCV  Set Monitor Receiver Input Source.           [1],[2]
  DSEL  Set Meter/Analyzer Display Select.           [M]easure,[C]alibrate
  ITSG  Inject Maser Test Signal.                   [OFF],[1],[2] [PRE],[PST]
  TALK  Talk Directly to GP-IB Equipment.            [SC],[TH],[AN],[SG],
  LSTN  Talk & Listen Directly to GP-IB Equip.      [PM],[D1],[D2],[MR]

PFEC>
  
```

Fig. 8. FEC configuration: help menu.

```

PFEC>stat c
PFEC Configuration Status (269 07:32:14) Configuration is UNLOCKED

      53.36K/MOD---+
      |
Horn/RCP-----+-----Maser 1-----+-----X=====RF 1
      |
8425 MHz/WB-----+-----+-----X=====Mon Rcvr
      |
Ambient Load-----+-----Maser 2-----+-----X=====RF 2
      |
      ND OFF/OFF---+
      |
                        8100 MHz

Local CRT has command locking privileges.

PFEC>

```

Fig. 9. FEC configuration status display: signal path.

```

PFEC>help m
PFEC Front End Controller Measurement Help...
The format for user input is: COMMAND PARAMETER

  Cmnd  Description                               Parameter

YFAC   Perform Y-factor Measurement.           [1],[2] [L]eft,[R]ight
GAIN   Compute Maser Gain Profile.             [1],[2]
PMTR   Operate Power Meter.                   [M]easure,[C]alibrate
CCRH   Chart CCR Performance History.         [1],[2] [MMddHHmm] [MMddHHmm]
SYST   Measure System Temperature (TPR).      [],[OFF],[C]ont,[D]isp,[n]sec
NRES   Set NAR Sample Resolution.             [n] deg K
NRAT   Set NAR Sample Rate.                   [n] Hz
DRAT   Set NAR Diode Switching Rate.          [n] Hz (Debug only)
NSAM   Set Number of Resolution Samples.      [n]
CALG   Calibrate System Gain Factor.          [] (CFG only)
CALD   Calibrate Noise Diodes.                [ALL],[n] deg K (CFG only)
DLTA   Measure System Linearity Delta.        [S]ky,[A]mbient,[F]ull Range

PFEC>

```

Fig. 10. FEC measurement: help menu.



```
PFEC>stat y 2
PFEC>STAT: Y-Factor Results for Maser 2, Right Polarization (271 10:28:39)
Average Ambient Load Power Level = -44.88 dBm
Average Ambient Load Temperature = 294.35 deg K
Average Antenna Power Level = -57.67 dBm
Average Antenna Temperature = 15.70 deg K
PFEC>
```

Fig. 11. FEC Y-factor measurement: status display.

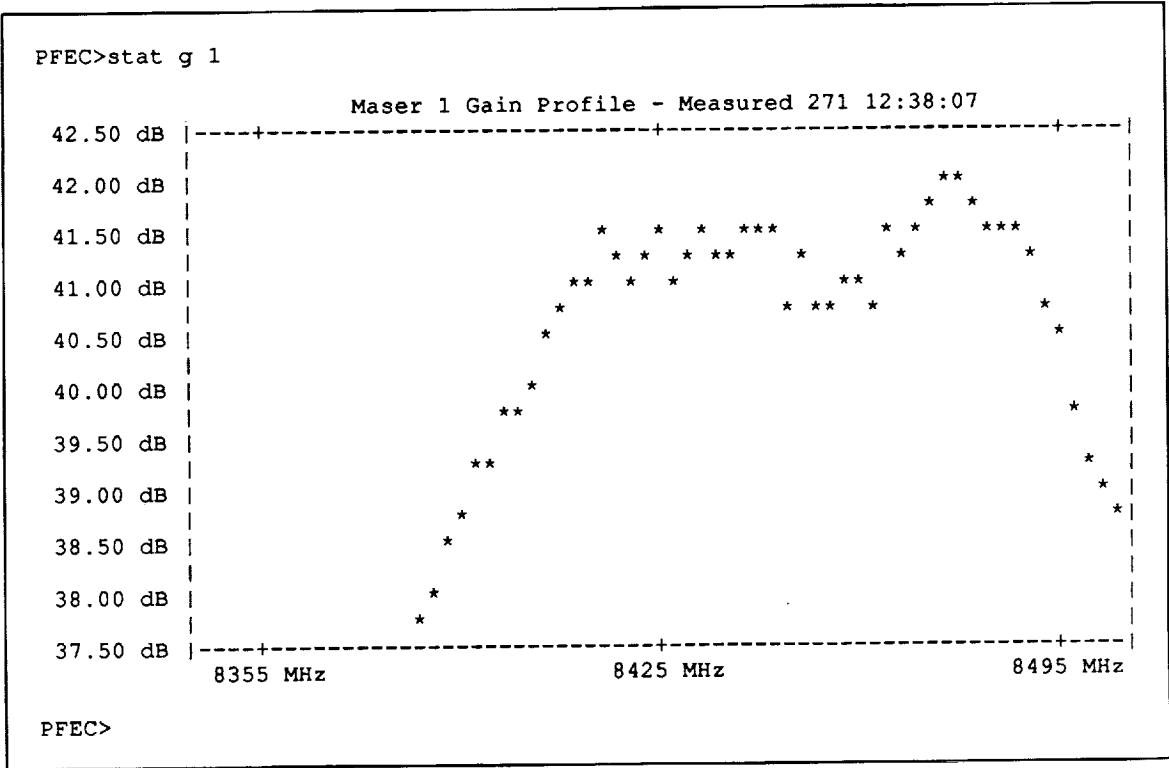

Fig. 12. FEC maser gain profile: status display.

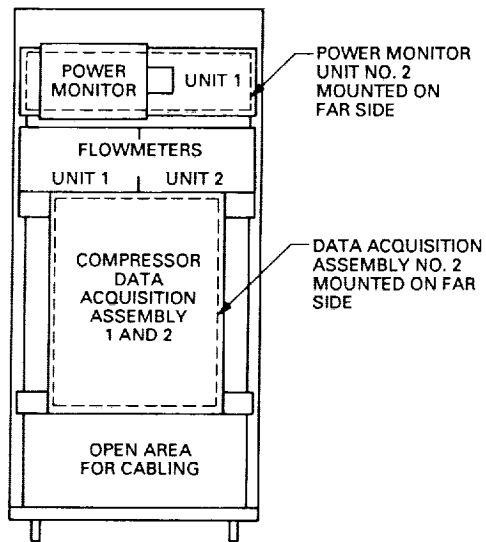

Fig. 13. Compressor data half-rack.

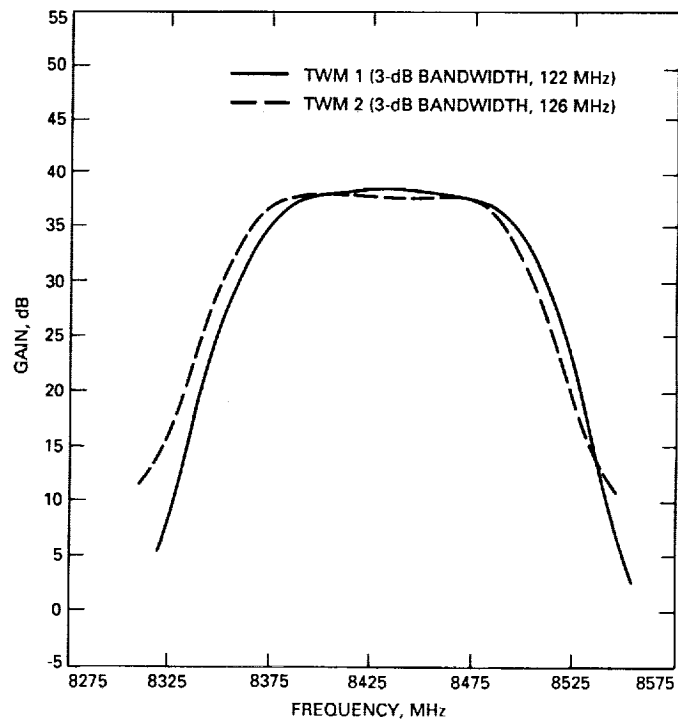

Fig. 15. TWMs 1 and 2 gain/bandwidth, after final adjustment.

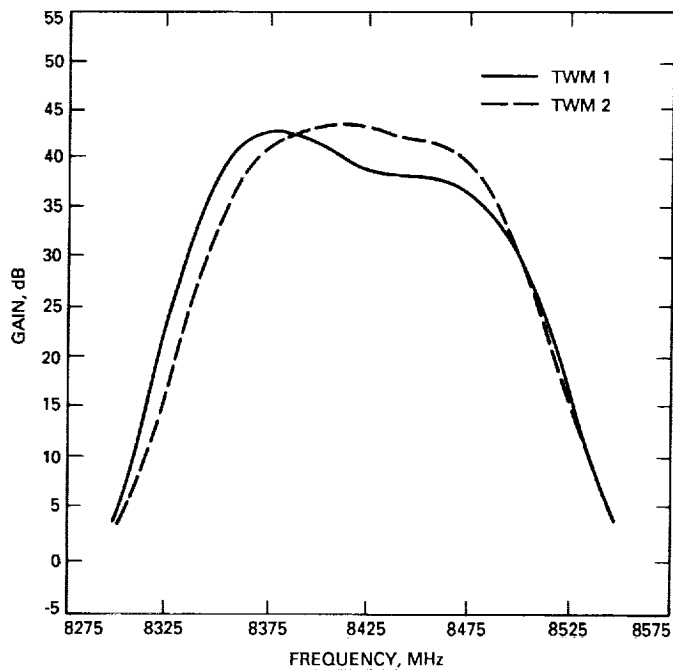

Fig. 14. TWMs 1 and 2 gain/bandwidth, prior to adjustment.

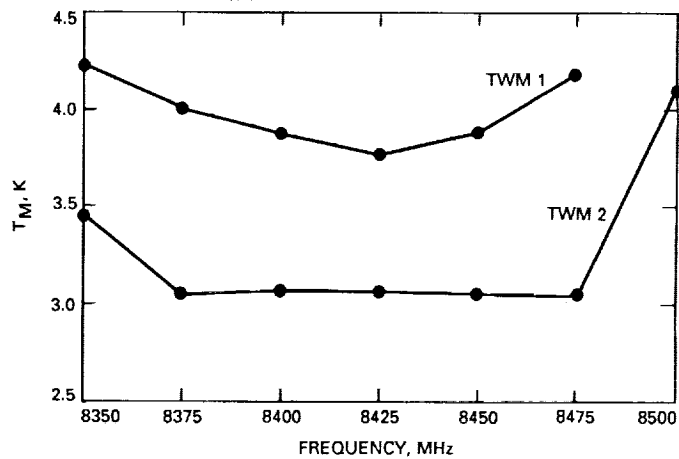
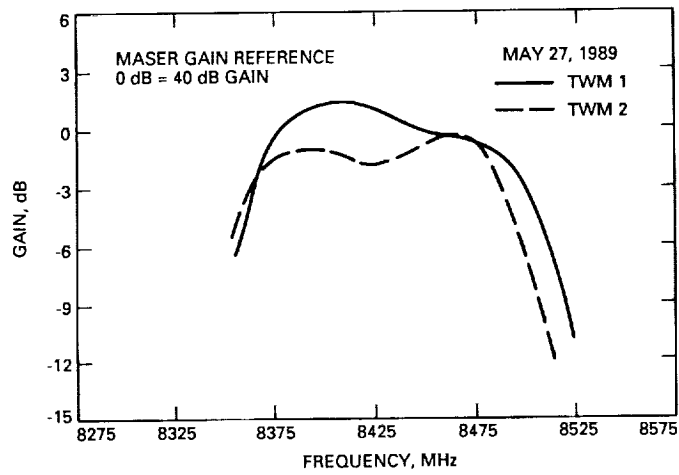

Fig. 16. TWMs 1 and 2 equivalent input noise temperature.



**Fig. 17. Gain/bandwidth curves after installation on the Parkes antenna.**