

NASA
Technical Memorandum 102395

AVSCOM
Technical Report 89-C-011

Computerized Inspection of Gear Tooth Surfaces

Faydor L. Litvin, Yi Zhang, and Jonathan Kieffer
University of Illinois at Chicago
Chicago, Illinois

Robert F. Handschuh
Propulsion Directorate
U.S. Army Aviation Research and Technology Activity—AVSCOM
Lewis Research Center
Cleveland, Ohio

and

John J. Coy
Lewis Research Center
Cleveland, Ohio

Prepared for the
SIAM Conference on Geometric Design
Tempe, Arizona, November 6-10, 1989

NASA

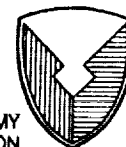

US ARMY
AVIATION
SYSTEMS COMMAND
AVIATION R&T ACTIVITY

(NASA-TM-102395) COMPUTERIZED INSPECTION OF
GEAR TOOTH SURFACES (NASA) 18 p CSCL 13T

N90-22054

Unclas
G3/37 0280228



COMPUTERIZED INSPECTION OF GEAR TOOTH SURFACES

Faydor L. Litvin, Yi Zhang, and Jonathan Kieffer
University of Illinois at Chicago
Chicago, Illinois 60680

Robert F. Handschuh
Propulsion Directorate
U.S. Army Aviation Research and Technology Activity - AVSCOM
Lewis Research Center
Cleveland, Ohio 44135

and

John J. Coy
National Aeronautics and Space Administration
Lewis Research Center
Cleveland, Ohio 44135

SUMMARY

E-5113

An approach is proposed that uses coordinate measurements of the real surface of spiral bevel gears to determine the actual machine tool settings applied during the gear manufacturing process. The deviations of the real surface from the theoretical one are also determined. Adjustments are then applied by machine tool corrections to minimize these surface deviations. This is accomplished by representing the real surface analytically in the same Gaussian coordinates as the theoretical surface.

1. INTRODUCTION

The development of computer-controlled machines has opened new opportunities for high-precision generation of double-curved surfaces - the surfaces of gear teeth, rotors, propellers, screws, etc. However, these opportunities can only be realized if the surface generation is complemented with coordinate measurements of the manufactured surfaces. Only with such measurements can the deviations of the real surface from the theoretical one be determined and then minimized by correcting the applied machine tool settings.

The Gleason Works (USA), Oerlikon (Switzerland), Caterpillar (USA), and the Ingersoll Milling Machine Company (USA) are pioneers in the development of computer-controlled machines for generating spiral bevel, hypoid, spur, and helical gears. Engineers at the Gleason Works have developed a system for automatically evaluating real gear tooth surfaces that is based on measurements taken with the Zeiss machine (ref. 1). Engineers at Caterpillar have developed their own machine for coordinate measurement and have used it for evaluating and correcting real gear tooth surfaces (ref. 2). Coordinate measurement of complicated surfaces is expected to find wide application in industry.

This paper covers the following topics:

(1) Numerical determination of machine tool settings for a real surface. Here it is assumed that the deviations of the real surface from the theoretical one are caused only by machine tool setting errors. The proposed approach allows the required corrections of machine tool settings to be determined from coordinate measurements.

(2) Determination of corrections of machine tool settings for a real surface with irregular deviations. Deviations can be caused by heat treatment and deflections during manufacturing. The proposed approach assumes that the manufacturing process provides repeatable surface deviations and allows the deviations to be minimized by appropriate corrections to the machine tool settings.

(3) Analytical representation of the real surface including the deviations that remain after correction by (2). The proposed approach allows the real surface to be represented in the same Gaussian coordinates as the theoretical surface so that computer-aided simulation of meshing and contact of the interacting surfaces (e.g., gear tooth surfaces) can be simplified.

The solution to these problems is illustrated by a numerical example.

2. REPRESENTATION OF A THEORETICAL SURFACE

A theoretical gear tooth surface is an envelope of the family of tool surfaces. Methods for their analytical representation are well known and have been described in reference 3.

The theoretical surface Σ_t may be represented in a parametric form in a coordinate system S_t rigidly connected to Σ_t as follows:

$$r_t(u, \theta; q_j) \in C^2 \quad (j = 1, 2, \dots, n); \quad u, \theta \in E; \quad \frac{\partial r_t}{\partial u} \times \frac{\partial r_t}{\partial \theta} \neq 0 \quad (1)$$

The designation C^2 means that the vector function has continuous derivatives for all arguments at least to the first and second orders. The Gaussian coordinates are designated by u and θ , and E is the area of u and θ . The inequality in equation (1) indicates that Σ_t is a regular surface. The machine tool settings are designated by constants q_j ($j = 1, 2, \dots, n$).

This approach requires a parametric representation of a surface that is equidistant from the theoretical surface. Such a surface is represented by

$$r_t(u, \theta) + \lambda n_t(u, \theta) \quad (\lambda \neq 0) \quad (2)$$

Here

$$n_t(u, \theta) = \frac{N_t}{|N_t|}; \quad N_t = \frac{\partial r_t}{\partial u} \times \frac{\partial r_t}{\partial \theta} \neq 0$$

where N_t is the vector of the surface normal; n_t is the unit surface normal; and λ is the scalar that determines the distance between the two surfaces.

3. PRINCIPLES OF COORDINATE MEASUREMENT

A coordinate measurement machine is supplied with a probe that can perform translational motions in three mutually perpendicular directions during the measurement process. The probe tip represents a changeable sphere whose diameter can be chosen from a wide range. Henceforth, we will consider that a coordinate system $S_m(X_m, Y_m, Z_m)$ is rigidly connected to the coordinate measurement machine, where Z_m corresponds to the axis of the gear (fig. 1). The axis of the probe may be installed parallel to Z_m (fig. 1(a)) or perpendicular to Z_m (fig. 1(b)) as is appropriate - depending on the pitch cone angle of a hypoid or spiral bevel gear, for example. The back face of the gear is its base plane, and the origin of the coordinate system S_m is located in the base plane or is related to it. A coordinate system $S_t(x_t, y_t, z_t)$ is rigidly connected to the gear being measured. In some cases we may assume that the origin O_t coincides with O_m . In the most general case the orientation and location of S_t with respect to S_m are determined with two parameters, δ and ϱ (fig. 2). These parameters can be determined by using the computational procedure described in section 4.

The coordinate measurement machine is provided with a rotary table. The table allows the gear to be installed in an initial position with respect to the probe. The measurement data provide the coordinates of the center of the probe tip sphere.

The coordinate measurement machine can be calibrated for a chosen probe tip sphere by using a calibration ring (fig. 3). The initial coordinates of the center of the tip sphere are

$$\begin{bmatrix} X_m^{(0)} \\ Y_m^{(0)} \\ Z_m^{(0)} \end{bmatrix} = \begin{bmatrix} R + a \\ 0 \\ f \end{bmatrix} \quad (3)$$

where R is the radius of the calibration ring, a is the radius of the sphere, and f is obtained by independent measurement. At the initial position the probe sphere is in contact with the calibration ring. The $Y_m = 0$ alignment is achieved by finding the Y_m position where equal displacements $\pm\Delta Y$ of the probe result in equal X_m direction displacements. Since the probe performs measurements by translational motion, its displacements in the X_m , Y_m , and Z_m axis directions represent displacements of the sphere center from the initial position.

4. DETERMINATION OF REAL MACHINE TOOL SETTINGS

Initial Considerations

All deviations of the real surface from the theoretical one are assumed to be only the result of errors in the applied machine tool settings. Then the real machine tool settings are determined from the coordinate measurement data.

Consider that the theoretical gear tooth surface and the unit surface normal are represented in coordinate system S_t by the following vector equations:

$$r_t = r_t[u, \theta; q_1^{(0)}, \dots, q_n^{(0)}] \quad (4)$$

$$n_t = n_t[u, \theta; q_1^{(0)}, \dots, q_n^{(0)}] \quad (5)$$

where $q_1^{(0)}, \dots, q_n^{(0)}$ represent the nominal machine tool settings. To represent the real surface and its unit normal in S_t , substitute the real machine tool settings to be determined (q_1, q_2, \dots, q_n) for the nominal values in equations (4) and (5).

Now consider an imaginary surface from the real surface at a distance equal to the radius of the probe sphere. This surface is represented in S_t by (see eq. (2))

$$\begin{aligned} x_t^{(e)} &= x_t(u, \theta; q_j) + a n_x(u, \theta; q_j) = A(u, \theta; q_j) \\ y_t^{(e)} &= y_t(u, \theta; q_j) + a n_y(u, \theta; q_j) = B(u, \theta; q_j) \\ z_t^{(e)} &= z_t(u, \theta; q_j) + a n_z(u, \theta; q_j) = C(u, \theta; q_j) \end{aligned} \quad (6)$$

where a is the radius of the probe sphere; A , B , and C represent the resulting functions; and $q_j (j = 1, \dots, n)$ are the unknown real machine tool settings.

Basic Equations

The real machine tool settings are determined as follows:

Step 1. - The coordinate transformation from S_t to S_m is based on the matrix equation

$$[r_m] = [M_{mt}] [r_t] \quad (7)$$

Here (see fig. 2)

$$[M_{mt}] = \begin{bmatrix} \cos \delta & \sin \delta & 0 & 0 \\ -\sin \delta & \cos \delta & 0 & 0 \\ 0 & 0 & 1 & d \\ 0 & 0 & 0 & 1 \end{bmatrix} \quad (8)$$

Considering that the measured coordinates of the probe sphere center (X_m, Y_m, Z_m) coincide with coordinates on the equidistant surface represented in S_m ,

$$\begin{bmatrix} X_m^{(e)} \\ Y_m^{(e)} \\ Z_m^{(e)} \end{bmatrix}^T = \begin{bmatrix} X_m \\ Y_m \\ Z_m \end{bmatrix}^T \quad (9)$$

Equations (6) to (9) yield

$$\begin{aligned} X_m &= A(u, \theta; q_j) \cos \delta + B(u, \theta; q_j) \sin \delta \\ Y_m &= -A(u, \theta; q_j) \sin \delta + B(u, \theta; q_j) \cos \delta \\ Z_m &= C(u, \theta; q_j) + \varrho \end{aligned} \quad (10)$$

Step 2. - The goal is to derive equations that are invariant with respect to the parameters δ and ϱ . The drawing of figure 2 yields

$$\rho^2 = X_m^2 + Y_m^2 = x_t^2 + y_t^2 = A^2(u, \theta; q_j) + B^2(u, \theta; q_j) \quad (11)$$

Using equation (11) yields

$$X_m^2 + Y_m^2 = A^2(u, \theta; q_j) + B^2(u, \theta; q_j) \quad (12)$$

Equations (10) yield

$$\tan \frac{\delta}{2} = \frac{A(A - X_m) + B(B - Y_m)}{BX_m - AY_m} \quad (13)$$

It is also evident that

$$\varrho = Z_m - C(u, \theta; q_j) \quad (14)$$

Step 3. - Henceforth, the subscript m , indicating that the coordinates of a point are represented in coordinate system S_m , is dropped. The number of measurement points is designated by d and the index of a measured point by the subscript p . The following system of equations, based on equations (12) to (14), is used for determining the real machine tool settings:

$$X_p^2 + Y_p^2 = A^2(u_p, \theta_p; q_j) + B^2(u_p, \theta_p; q_j) \quad (p = 1, 2, \dots, d) \quad (15)$$

$$\frac{A_p(A_p - X_p) + B_p(B_p - Y_p)}{B_p X_p - A_p Y_p} = \frac{A_{p+1}(A_{p+1} - X_{p+1}) + B_{p+1}(B_{p+1} - Y_{p+1})}{B_{p+1} X_{p+1} - A_{p+1} Y_{p+1}} \quad (16)$$

$$(1 \leq p \leq d - 1)$$

$$Z_{p+1} - Z_p = C(u_{p+1}, \theta_{p+1}; q_j) - C(u_p, \theta_p; q_j) \quad (1 \leq p \leq d - 1) \quad (17)$$

From the results of measurements for d points on the surface, $(3d - 2)$ equations can be obtained for equations (15) to (17) in $2d$ unknown surface coordinates (u_p, θ_p) and n unknown machine tool settings $q_j (j = 1, \dots, n)$. Thus, determining n unknown machine tool settings requires

$$d = n + 2; \quad k = 3d - 2 = 3n + 4 \quad (18)$$

where d is the number of surface measurements and k is the number of non-linear equations that have to be solved. The parameters δ and ϱ , orienting and locating coordinate system S_t with respect to S_m (fig. 2), can be determined from equations (13) and (14).

If $\varrho = 0$ (the origin O_t coincides with O_m), the following equation may be used in place of equation (17):

$$Z_p = C(u_p, \theta_p; q_j) \quad (19)$$

For this case the coordinate measurements of d points on the real surface result in $(3d - 1)$ equations (15), (16), and (19) in $2d$ unknown surface coordinates (u_p, θ_p) and n unknown machine tool settings $q_j (j = 1, 2, \dots, n)$. To determine the n unknown machine tool settings, use

$$d = n + 1; \quad k = 3d - 1 = 3n + 2 \quad (20)$$

Computational Procedure

The numerical solution of a large system of nonlinear equations is a complicated problem. For the case where $\varrho \neq 0$ and $n = 4$ the number of equations to be solved according to equation (18) is $k = 16$. The system of nonlinear equations can be solved by using computer software such as the IMSL subroutine DNEQNF. However, the successful application of this program requires a good first guess - an initial set of unknowns that is used for the first iteration. We propose a solution procedure that begins with a system of four equations using only the measurements for two points on the surface. This number of equations, $k = 4$, and the number of measurements, $d = 2$, can be obtained from equation (18) considering that $n = 0$. This means that, for the first step, errors in the machine tool settings are neglected and the machine tool variables q_1, q_2, \dots, q_n in equations (15) to (17) are set to the nominal values $q_1^{(0)}, q_2^{(0)}, \dots, q_n^{(0)}$.

Step 1. - An initial guess for the system of four equations is obtained as follows: (1) an approximate value for ϱ is determined by measurements and then (2) neglecting the errors for machine tool settings, approximate values for the surface coordinates of two measured points are determined by using the following equations:

$$C(u_p, \theta_p) = Z_p - 1 \quad (p = 1, 2) \quad (21)$$

$$A^2(u_p, \theta_p) + B^2(u_p, \theta_p) = X_p^2 + Y_p^2 \quad (p = 1, 2) \quad (22)$$

Step 2. - Once the appropriate values of (u, θ) for the two measured points are known, more precise solutions for the surface coordinates can be obtained by using the system of four equations

$$A^2(u_1, \theta_1) + B^2(u_1, \theta_1) = X_1^2 + Y_1^2 \quad (23)$$

$$A^2(u_2, \theta_2) + B^2(u_2, \theta_2) = X_2^2 + Y_2^2 \quad (24)$$

$$C(u_2, \theta_2) - C(u_1, \theta_1) = Z_2 - Z_1 \quad (25)$$

$$\frac{A_1(A_1 - X_1) + B_1(B_1 - Y_1)}{B_1X_1 - A_1Y_1} = \frac{A_2(A_2 - X_2) + B_2(B_2 - Y_2)}{B_2X_2 - A_2Y_2} \quad (26)$$

obtained for equations (15) to (17) by considering that $d = 2$ and neglecting errors in the machine tool settings.

Step 3. - The solution obtained for the previous step is then used as the initial guess for a larger system of $k = 7$ equations (15) to (17), obtained by considering that one machine tool setting is a variable and using $d = 3$ measurement points.

Step 4. - The number of machine tool settings that are considered as variables is gradually increased until the exact values for the whole set of $j = 1, 2, \dots, n$ unknown machine tool settings are eventually determined by using a system of $k = 3n + 4$ equations (15) to (17). Knowing the real values of the machine tool settings allows the settings to be corrected and the deviations of the real surface from the theoretical one to be eliminated.

In some cases the real tooth surface is substantially distorted because of problems other than errors in the machine tool settings. The procedure described in section 5 can be used to improve the precision of the generated surface.

5. MINIMIZATION OF DEVIATIONS OF THE REAL SURFACE

Now consider the case where the deviations of the real surface from the theoretical one are caused by many factors - not just errors in machine tool settings. It is assumed that the process of manufacturing, including heat treatment, provides repeatable deviations. The surface deviations may then be compensated for (but not made zero) by using directed corrections to the initially applied machine tool settings. The procedure for determining the corrected machine tool settings is based on minimizing an objective function in n variables that describes the real surface deviations; n is the number of machine tool settings to be corrected.

The following stages of solution to this problem are considered: (1) determination of the orientation of the coordinate system S_t with respect to S_m (fig. 2); (2) determination of the deviations of the real surface; and (3) derivation and minimization of an objective function (described later in this paper).

Determination of Orientation Parameter δ

The gear is assumed to be installed on the coordinate measurement machine flush against a base plate such that the parameter ϱ is known (for convenience, take $\varrho = 0$). Furthermore, it is assumed that the probe can be initially installed at a specified position and that the gear can be rotated until it contacts the probe at this position. The specified position of the probe is determined from the equations for tangency of the probe with the theoretical surface at a selected surface reference point M. This point can be chosen as the middle point of the surface and is given by surface coordinates (u^*, θ^*) that determine M and the unit surface normal at M.

The equations for tangency of the probe sphere and the theoretical surface at M are derived by using equations (6) to (8) and considering that the parameter ϱ in matrix (8) is zero. Equations (6) to (8) represent a system of three equations in four unknowns: X_m , Y_m , Z_m , and δ . If $Y_m = 0$, then X_m , Z_m , and δ can be determined from the following set of equations derived from equations (12) to (14):

$$\begin{aligned} X_m^2 &= A^2[u^*, \theta^*; q_j^{(0)}] + B^2[u^*, \theta^*; q_j^{(0)}] \\ Z_m &= C[u^*, \theta^*; q_j^{(0)}] \\ \tan \frac{\delta}{2} &= \frac{A^2[u^*, \theta^*; q_j^{(0)}] - X_m A[u^*, \theta^*; q_j^{(0)}]}{X_m B[u^*, \theta^*; q_j^{(0)}]} \end{aligned} \quad (27)$$

Here (u^*, θ^*) are the surface coordinates of the chosen reference point M; $q_j^{(0)}$ ($j = 1, 2, \dots, n$) are the theoretical machine tool settings; and $(X_m, 0, Z_m)$ are the coordinates of the center of the probe sphere that is to be installed on the coordinate measurement machine. If, in the installation of the probe, the actual coordinates $(X_m, 0, Z_m)$ differ from the calculated ones, the values of u^* , θ^* , and δ must be corrected by using equation (27).

Determination of Deviations

Once the orientation parameter δ is known, the theoretical surface can be represented in coordinate system S_m . Consider that $R_p(X_p, Y_p, Z_p)$ is the position vector of the center C of the probe sphere and that this point lies on the line of action of the theoretical surface normal at a point T of the theoretical surface Σ_t (fig. 4). The vector equation is

$$R_p = r_p [u_p, \theta_p; q_j^{(0)}] + \lambda_p n_p [u_p, \theta_p; q_j^{(0)}] \quad (28)$$

Here (u_p, θ_p) are the curvilinear coordinates of point T of Σ_t ; $q_j^{(0)}$ ($j = 1, 2, \dots, n$) are the theoretical machine tool settings; and λ_p is the distance between T and C.

Equation (28) yields a system of three equations in the unknowns $(u_p, \theta_p, \lambda_p)$ that can be represented as

$$\begin{aligned} \frac{x_p - x_p[u_p, \theta_p; q_j^{(0)}]}{n_{xp}[u_p, \theta_p; q_j^{(0)}]} &= \frac{y_p - y_p[u_p, \theta_p; q_j^{(0)}]}{n_{yp}[u_p, \theta_p; q_j^{(0)}]} \\ &= \frac{z_p - z_p[u_p, \theta_p; q_j^{(0)}]}{n_{zp}[u_p, \theta_p; q_j^{(0)}]} = \lambda_p(u_p, \theta_p) \end{aligned} \quad (29)$$

where $p = (1, 2, \dots, d)$; $j = (1, 2, \dots, n)$; and all coordinates are represented in coordinate system S_m .

The procedure of computation is as follows:

Step 1. - The surface coordinates for a measurement point can be determined from the equations

$$f_1(u_p, \theta_p) = [n_{yp}(x_p - x_p) - n_{xp}(y_p - y_p)] = 0 \quad (30)$$

$$f_2(u_p, \theta_p) = [n_{zp}(y_p - y_p) - n_{yp}(z_p - z_p)] = 0 \quad (31)$$

Step 2. - The value of λ_p can be determined by using any of the three equations of system (29).

Step 3. - The deviation Δ_p of the real surface from the theoretical surface can be determined by considering that the point of tangency of the probe sphere with the real surface lies at a distance a equal to the radius of the probe sphere (fig. 4). Thus, the position vector M_p of the point on the real surface Σ_r is given by

$$M_p = r_p[u_p, \theta_p; q_j^{(0)}] + \Delta_p n_p[u_p, \theta_p; q_j^{(0)}] \quad (32)$$

where

$$\Delta_p = \lambda_p - a \quad (33)$$

Image Surface

The process of manufacturing initially provides the theoretical surface Σ_t , but owing to unknown factors the surface Σ_t becomes distorted into the real surface Σ_r represented numerically by equation (32). If the deviations are repeatable, the inevitable distortion can be prepared for and the deviations in the final manufactured surface minimized by generating, not the theoretical surface Σ_t , but an image surface Σ_r^* represented by

$$M_p^*(u_p, \theta_p) = r_p[u_p, \theta_p; q_j^{(0)}] - \Delta_p n_p[u_p, \theta_p; q_j^{(0)}] \quad (34)$$

Comparing equations (32) and (34) shows that Σ_r^* is the image of Σ_r reflected through the theoretical surface Σ_t (see fig. 4). Henceforth, Σ_r^* will be referred to as the image surface.

Although Σ_r^* is the surface to be generated, it cannot be provided exactly with the existing generation process. The surface Σ_r^* can only be approximated with a corrected surface Σ_t^* represented by the vector function

$$r_p^*(u_p, \theta_p; q_j) \quad (35)$$

Here the designation q_j instead of $q_j^{(0)}$ means that new machine tool settings must be applied for generating Σ_t^* . The deviation of Σ_r^* from Σ_t^* can be determined by using equations that are similar to equation (29):

$$\begin{aligned} \frac{X_p^* - x_p(u_p^*, \theta_p^*; q_j)}{n_{xp}(u_p^*, \theta_p^*; q_j)} &= \frac{Y_p^* - y_p(u_p^*, \theta_p^*; q_j)}{n_{yp}(u_p^*, \theta_p^*; q_j)} \\ &= \frac{Z_p^* - z_p(u_p^*, \theta_p^*; q_j)}{n_{zp}(u_p^*, \theta_p^*; q_j)} = \Delta_p^*(u_p^*, \theta_p^*; q_j) \end{aligned} \quad (36)$$

The designation (u_p^*, θ_p^*) instead of (u_p, θ_p) means that the surface coordinates associated with each measurement p will be changed, since new machine tool settings are applied.

Determination of Corrected Machine Tool Settings

The goal is to determine new machine tool settings such that the differences Δ_p^* ($p = 1, 2, \dots, d$) between the surfaces Σ_r^* and Σ_t^* are minimized. The solution to this problem is based on the minimization of the objective function

$$F = \sum_{p=1}^d a_p (\Delta_p^*)^2 \quad (37)$$

where F is a function of n variables, the machine tool settings q_j ($j = 1, 2, \dots, n$); and a_p are the weighting coefficients. The use of weighting coefficients allows smaller deviations to be provided at points where higher precision is required.

Numerical Example

The results of measuring a Formate hypoid gear are represented in figures 5 and 6. The number of measured points is $d = 45$. Figure 5 illustrates the deviations $\Delta_p (p = 1, 2, \dots, 45)$ of the real surface from the theoretical one. The locations of measured points are represented on a plane, and the deviations Δ_p are shown as normal displacements from the plane. Figure 6 represents the same data on a plot. Each latitudinal cross section of figure 5 is represented by a line segment in figure 6. Figure 7 shows the deviations of the imaginary surface Σ_r^* to which the corrected theoretical surface Σ_t^* is to be fitted.

The deviations Δ_p^* between the surfaces Σ_t^* and Σ_r^* were minimized numerically through use of equation (33) and the quasi-Newton method (ref. 4) as implemented in the IMSL subroutine UMNIF. The weighting coefficient $a_p = 1$ was used. Figure 8 shows the deviations from the theoretical of both the image Σ_r^* and the fitted image surface Σ_t^* . Figure 9 is a three-dimensional representation of the deviation of the fitted image surface Σ_t^* from the theoretical one.

6. ANALYTICAL REPRESENTATION OF THE REAL SURFACE

As was mentioned previously, two cases of deviation from the real surface may be considered: (1) when the deviations are caused only by using the wrong machine tool settings, and (2) when the deviations are caused by many unknown factors. In the first case the real surface can be represented by the same equations as the theoretical one just by substituting the theoretical settings for the real ones (section 4). In the second case the deviations can be minimized by correcting the applied machine tool settings, and the problem is to represent analytically the new real surface obtained by manufacturing a new gear with the corrected machine tool settings. The goal is to represent this surface as the sum of two vector functions:

$$\mathbf{r} = \mathbf{r}_t[u, \theta; q_j^{(0)}] + \Delta \mathbf{r}(u, \theta) \quad (38)$$

Here the vector function $\mathbf{r}_t[u, \theta; q_j^{(0)}]$ is the same as that for the theoretical surface; and $\Delta \mathbf{r}(u, \theta)$ is an analytical vector function of the deviations of the new surface from the theoretical one. Even though the new gear was not manufactured by using the nominal settings $q_j^{(0)}$, its representation is based on $\mathbf{r}_t[u, \theta; q_j^{(0)}]$ because the corrected machine tool settings were designed to bring the final manufactured surface closer to $\mathbf{r}_t[u, \theta; q_j^{(0)}]$.

If new measurements and the procedure of section 5 are used, the new surface can be represented numerically by equation (32). Since the numerical

deviations Δ_p can be represented analytically as $\Delta(u,\theta)$, the new surface can be represented by

$$r(u,\theta) = r_t[u,\theta; q_j^{(0)}] + \Delta(u,\theta)n_t[u,\theta; q_j^{(0)}] \quad (39)$$

However, the equations for the surface normal of the surface represented earlier derived from

$$n_r = \frac{N_r}{|N_r|}; \quad N_r = \frac{\partial r}{\partial u} \times \frac{\partial r}{\partial \theta} \quad (40)$$

become too complicated for practical use in tooth contact analysis. For this reason it is simpler to consider the deviations of the real surface as measured along a vector of constant direction - for instance, along the unit surface normal n° to the theoretical surface at the reference point. Such deviations can be determined by using the following equations, similar to equations (29) and (33):

$$\begin{aligned} \frac{x_p - x_p(u_p, \theta_p; q_j^{(0)})}{n_x^\circ} &= \frac{y_p - y_p(u_p, \theta_p; q_j^{(0)})}{n_y^\circ} \\ &= \frac{z_p - z_p(u_p, \theta_p; q_j^{(0)})}{n_z^\circ} = \lambda_p^\circ(u_p, \theta_p) \end{aligned} \quad (41)$$

$$\Delta_p^\circ = \lambda_p^\circ - a \quad (42)$$

Here $n^\circ(n_x^\circ, n_y^\circ, n_z^\circ)$ is the unit normal to the theoretical surface at the reference point; (x_p, y_p, z_p) are the current coordinates of the center of the probe sphere; a is the radius of the probe sphere; and Δ_p° is the surface deviation in the direction of n° .

Given that the numerical deviations $\Delta_p^\circ(u_p, \theta_p)$ $p = 1, 2, \dots, d$ have been determined, the problem of fitting a function $\Delta^\circ(u, \theta)$ to the numerical data can be approached in a number of ways. A common approach to such a problem is to fit piecewise polynomial functions to the data, such that the resulting function goes through all of the data and is smooth at the boundary between pieces (ref. 5). This approach is not applicable to the given problem for two reasons. First, the large number of segments of polynomial functions further complicates the analytic representation, making tooth contact analysis and simulation of meshing more difficult. Second, it is unreasonable to assume that the data are so precise that the desired analytical representation must match the data at every point.

A good solution to this problem is one that satisfies the two conflicting goals. The solution must result in a simple expression for $\Delta^\circ(u, \theta)$ and must represent the numerical data with good accuracy. We thus propose to determine $\Delta^\circ(u, \theta)$ by using linear multiple regression analysis (ref. 6). In particular,

if a solution of the following form is assumed:

$$\Delta^{\circ}(u,\theta) = b_0 + b_1 f_1(u,\theta) + b_2 f_2(u,\theta) + \dots + b_k f_k(u,\theta) \quad (43)$$

where b_0, b_1, \dots, b_k are undetermined coefficients and $f_1(u,\theta), f_2(u,\theta), \dots, f_k(u,\theta)$ are any set of linearly independent functions of u and θ not involving unknown parameters. Then linear multiple regression can be used to determine the coefficients b_0, b_1, \dots, b_k that provide a least-squares fit of equation (43) to the numerical data. Computer programs for linear multiple regression analysis exist in various software packages such as the IMSL statistics library and the SPSS statistics program. This software can solve equation (43) for the unknown coefficients, provide statistics on the expected error of the approximation, and automatically test various combinations of user-supplied functions to allow the user to select the best subset of functions. Although the technique allows for general functions $f_1(u,\theta), f_2(u,\theta), \dots, f_k(u,\theta)$, real data suggest that the deviations can be sufficiently represented by a second-order polynomial:

$$\Delta^{\circ}(u,\theta) = b_0 + b_1 u + b_2 \theta + b_3 u^2 + b_4 \theta^2 + b_5 u\theta \quad (44)$$

7. CONCLUSIONS

In this paper an overview has been presented describing the interrelationships between gear geometry, manufacture, and measurement. A methodology also has been presented to improve convergence between theoretical and manufactured surfaces by adjusting the machine tool settings during manufacture. This process can be carried out at several stages of gear manufacture (e.g., cutting and grinding) if so desired. The methodology can even be used to decrease the distortion effect of other manufacturing processes such as heat treatment.

The following specific results were obtained:

1. A process was devised for determining the real machine tool settings based on coordinate measurement of the manufactured gear.
2. A procedure for minimizing deviations of the real surface by correcting the machine settings was developed.
3. An approach for analytically representing the real gear surface was developed.

REFERENCES

1. P. Bezier, The Mathematical Basis of the UNISURF CAD System, Butterworth, 1986.
2. R.O. Chambers and R.E. Brown, Coordinate Measurement of Bevel Gear Teeth, SAE International Off-Highway and Powerplant Congress, SAE Paper 871645, 1987.
3. C. Daniel and F.S. Woods, Fitting Equations to Data, Wiley, 1971.

4. Dennis J.E., Jr, and R.B. Schnabel, Numerical Methods for Unconstrained Optimization and Nonlinear Equations, Prentice-Hall, 1983.
5. G-AGE T.M. User's Manual for the Gleason Automated Gear Evaluation System Used With Zeiss Coordinate Measuring Machines. Gleason Works, Rochester, NY, 1987.
6. F.L. Litvin, Theory of Gearing, NASA RP-1212, 1989.

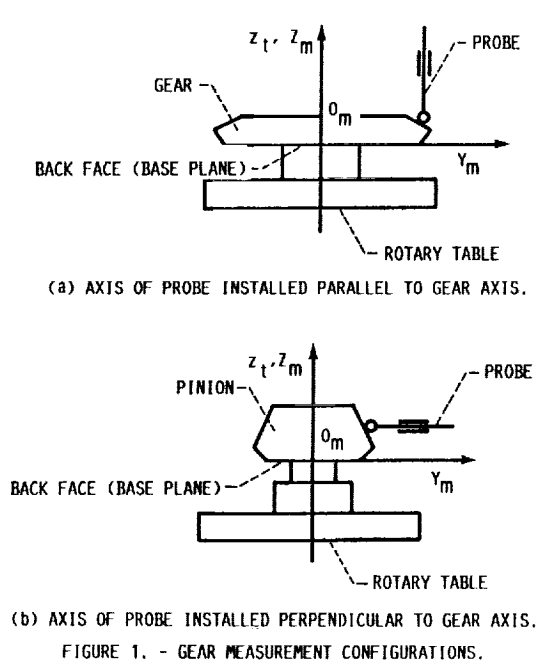

FIGURE 1. - GEAR MEASUREMENT CONFIGURATIONS.

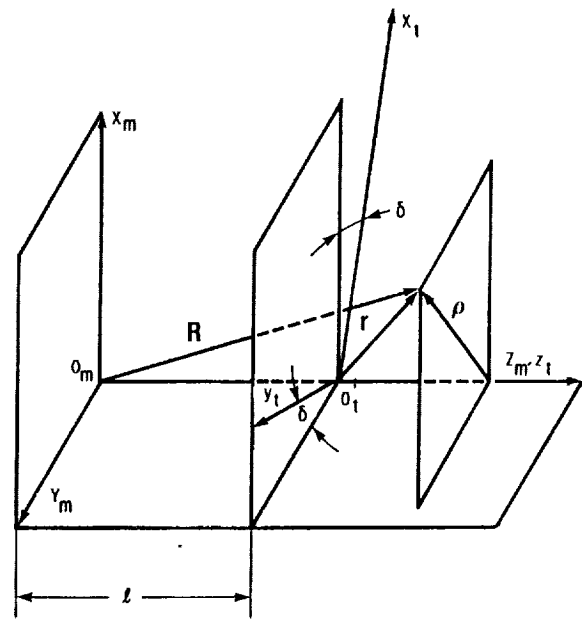

FIGURE 2. - COORDINATE TRANSFORMATION.

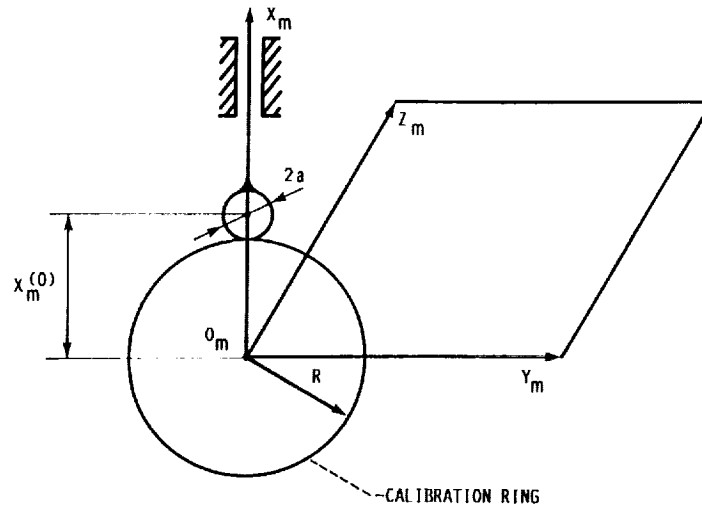

FIGURE 3. - CALIBRATION FOR MEASUREMENT.

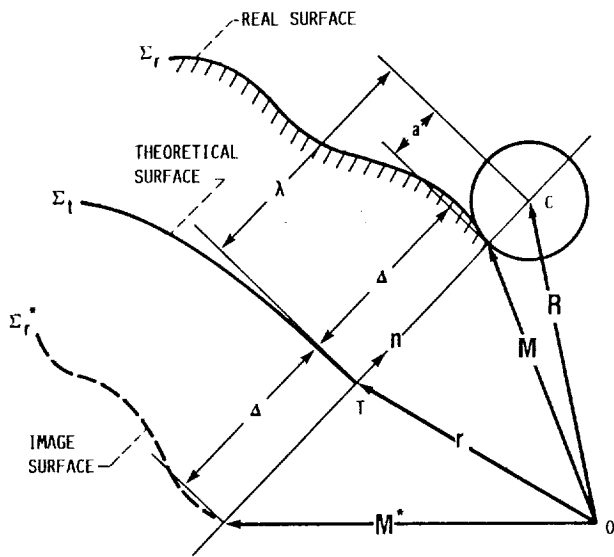

FIGURE 4. - SURFACE NOTATIONS.

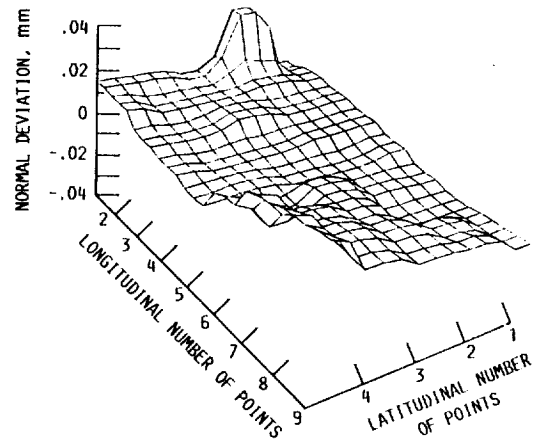

FIGURE 5. - DEVIATION OF REAL SURFACE Σ_r .

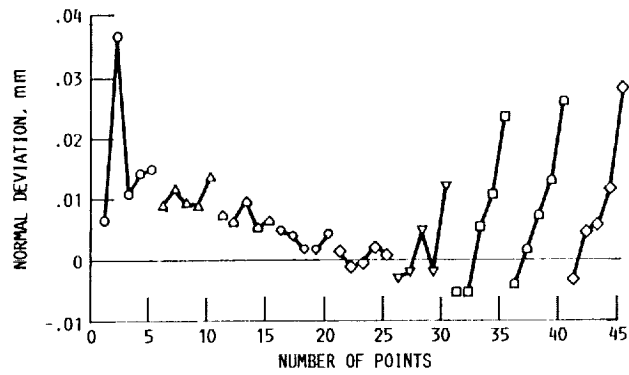

FIGURE 6. - PLOT OF DEVIATION OF REAL SURFACE Σ_r .

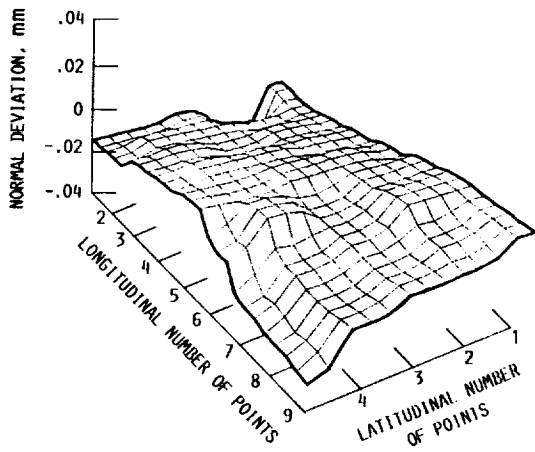

FIGURE 7. - DEVIATION OF IMAGE SURFACE Σ_r^* .

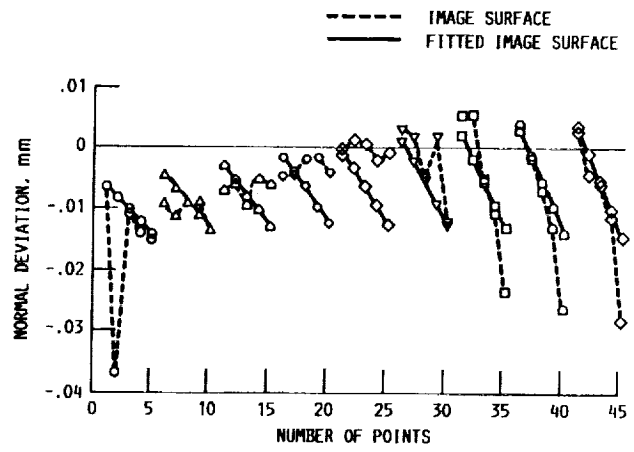

FIGURE 8. - PLOT OF DEVIATIONS OF IMAGE SURFACE Σ_r^* AND FITTED IMAGE SURFACE Σ_t^* .

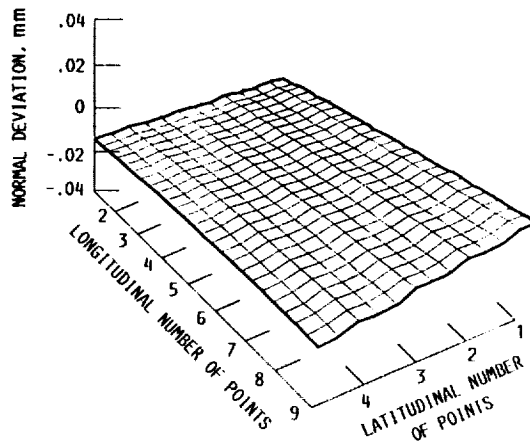

FIGURE 9. - DEVIATION OF FITTED IMAGE SURFACE Σ_t^* .



Report Documentation Page

1. Report No. NASA TM-102395 AVSCOM TM 89-C-011	2. Government Accession No.	3. Recipient's Catalog No.	
4. Title and Subtitle Computerized Inspection of Gear Tooth Surfaces		5. Report Date	
		6. Performing Organization Code	
7. Author(s) Faydor L. Litvin, Yi Zhang, Jonathan Kieffer, Robert F. Handschuh, and John J. Coy		8. Performing Organization Report No. E-5113	
		10. Work Unit No. 505-63-51 1L162209AH47A	
9. Performing Organization Name and Address NASA Lewis Research Center Cleveland, Ohio 44135-3191 and Propulsion Directorate U.S. Army Aviation Research and Technology Activity—AVSCOM Cleveland, Ohio 44135-3127		11. Contract or Grant No.	
		13. Type of Report and Period Covered Technical Memorandum	
12. Sponsoring Agency Name and Address National Aeronautics and Space Administration Washington, D.C. 20546-0001 and U.S. Army Aviation Systems Command St. Louis, Mo. 63120-1798		14. Sponsoring Agency Code	
		15. Supplementary Notes Prepared for the SIAM Conference on Geometric Design, Tempe, Arizona, November 6-10, 1989. Faydor L. Litvin, Yi Zhang, and Jonathan Kieffer, University of Illinois at Chicago, Chicago, Illinois 60680; Robert F. Handschuh, Propulsion Directorate, U.S. Army Aviation Research and Technology Activity—AVSCOM; John J. Coy, NASA Lewis Research Center.	
16. Abstract An approach is proposed that uses coordinate measurements of the real surface of spiral bevel gears to determine the actual machine tool settings applied during the gear manufacturing process. The deviations of the real surface from the theoretical one are also determined. Adjustments are then applied by machine tool corrections to minimize these surface deviations. This is accomplished by representing the real surface analytically in the same Gaussian coordinates as the theoretical surface.			
17. Key Words (Suggested by Author(s)) Gears Gear inspection Spiral bevel gears Gear geometry		18. Distribution Statement Unclassified—Unlimited Subject Category 37	
19. Security Classif. (of this report) Unclassified	20. Security Classif. (of this page) Unclassified	21. No of pages 18	22. Price* A03

