

776
N90-22094ORBITAL MANEUVERING VEHICLE (OMV)
THREE-POINT DOCKING LATCH

W. Neill Myers, John C. Forbes, and Wayne L. Barnes*

ABSTRACT

The primary purpose of the OMV is to dock with orbiting payloads and then either transfer them to a different orbit or return them to the Space Shuttle for servicing. Some such missions will involve docking with payloads equipped with a Flight Support System (FSS) type of interface; an example is the Hubble Space Telescope (HST). This paper describes the design and development of a mechanism to be used for testing this docking concept on the MSFC test beds. The test results to date are also presented.

HISTORY

The FSS interface was developed as a standard means of supporting payloads while in the Shuttle cargo bay, and, with the aid of the Shuttle Remote Manipulator System, it was intended for berthing operations only. However, the OMV is required to dock with payloads equipped with this interface. While these docking conditions can be computer simulated, testing is required to verify this model and discover any potential design problems. Therefore, beginning early in the OMV program, MSFC developed the hardware required for this testing.

DESIGN AND OPERATION

The test hardware consists of three latches and mounting structure which simulates the OMV Three-Point Docking Mechanism (TPDM; See Figure 1). The HST FSS trunnions were used in sizing the latch. The "three-point docking" interface consists of three 1.5 inch diameter trunnion rails equally spaced on the payload at a six foot diameter mounting circle.

The latch mechanism design has several unique features in relation to existing mechanisms of its type. These are:

- o Trunnion rail sensing and automatic operation
- o A relatively large capture envelope
- o Speed control for relatively quick trunnion containment and slow trunnion pulling/latching
- o A large pulling force capability
- o The ability to capture a rail without precise alignment

*NASA, Marshall Space Flight Center, Huntsville, Alabama

- o After capture, the ability to lock the trunnion onto the supporting structure, thereby removing the handling loads from the drive mechanism, and
- o The ability to release the latches to free the trunnion rail.

The latch mechanism (See Figures 2 and 3) includes three intermeshing rotatable fingers which are located between two faceplates. The V-shaped cutout in these plates defines the capture envelope for a trunnion (+/- 3.5 inches wide by 4.0 inches deep). The power for the fingers is supplied by a one foot-pound torque motor acting through a harmonic drive with a speed reduction of 160:1.

The operation of a single latch begins with the fingers fully open and clear of the capture envelope. When a trunnion rail enters the envelope, this action is detected by the breaking of an infrared beam which spans the upper section of the V-shape. Through electronics, the fingers are commanded to close at a set rate controlled by tachometer feedback. A second infrared beam is used to detect any escape of the trunnion prior to its containment by the fingers. When this containment position is reached, as determined by a rotary potentiometer, latch closure ceases.

At this point, the fingers would contain the trunnion until the other two trunnions have been contained by their respective latches. All three latches will then be commanded to close at a slow rate (to limit the accelerations imparted to the captured payload).

As a trunnion is pulled into the latch recess, it moves past four locking pawls and deflects a spring loaded pad. When the pad deflection reaches a given point, the spring loaded locking pawls open to contain the trunnion. A linear variable displacement transducer (LVDT) under the pad signals that this point has been reached, and power to the latch motor is cutoff. The trunnion is thus locked between the locking pawls and the spring loaded pad.

The faceplate/finger assembly is mounted on a base by a pivot pin. This allows the assembly to cock (+/- 5^o) until stop surfaces are reached. A leaf spring, which is attached to the pivot pin and retained in the base by pins, provides centering. The ability of the mechanism to cock about the pivot allows the trunnion crossbar to fully enter the recess and engage all four pawls, even if the crossbar was not originally parallel to the recess.

When the captured payload is to be released, the latches are commanded to open. As the fingers of a latch reach the fully open position, they actuate cam mechanisms which retract the locking pawls via links and free the trunnion. This is indicated by the LVDT position and the latch opening is stopped.

TESTING

Phase one of testing involved the use of a single latch mechanism to verify that both MSFC test facilities, the Flat Floor and the Six Degree-of-Freedom (6-DOF) Test Bed, give consistent results. The Flat Floor facility tests involved attaching the mechanism to an air bearing vehicle which was propelled at various speeds (up to 0.1 ft/sec) and trajectories across a flat epoxy floor. Latch operation began when a trunnion rail, which was fixed to a massive stationary structure, entered the capture envelope. The contact of the two simulated vehicles was much more dynamic than had been predicted. Some test cases, which were within the requirement ranges for OMV, nearly resulted in trunnion escape. These cases reinforced MSFC's argument that the OMV TPDM should have automatic closure due to the three second OMV to ground time delay.

About half of the fifty Flat Floor tests were repeated at the 6-DOF facility. This test bed uses computer controlled hydraulic actuators to move a large table to which the test mechanism is mounted. The payload docking interface is attached to the ceiling. The test parameters were setup to simulate the Flat Floor vehicle and a 3-DOF system. Kinematic data from these tests compared extremely well with the data from the earlier tests. The 6-DOF facility, having been calibrated and validated, could now be used for Phase two testing.

The objective of Phase two is to measure, analyze and document TPDM contact dynamics with the 6-DOF facility. Docking of the OMV with various payloads (from about 3000 to 78000 pounds) will be simulated by using three of the latch mechanisms. The 25000 pound HST will be given special emphasis. Issues to be investigated include latch closing profile and sequence, docking loads, and optimum infrared sensor location. This test phase is scheduled to begin in February 1990.

Phase three will involve piloted control of the docking process and will verify man-in-the-loop operations with the TPDM. This series of tests is to be performed later in 1990.

CONCLUSIONS

The tests performed to date have resulted in several changes to the OMV TPDM latch design. These include the change to a V-shaped capture envelope which is very similar to MSFC's design. This change provides for more predictable contact dynamics as well as the added material required for mounting the infrared sensors. The other design modifications include provisions for automatic closure and two step/two speed operation. Hopefully, the results of test phases two and three will determine if the latch design needs further refinement.

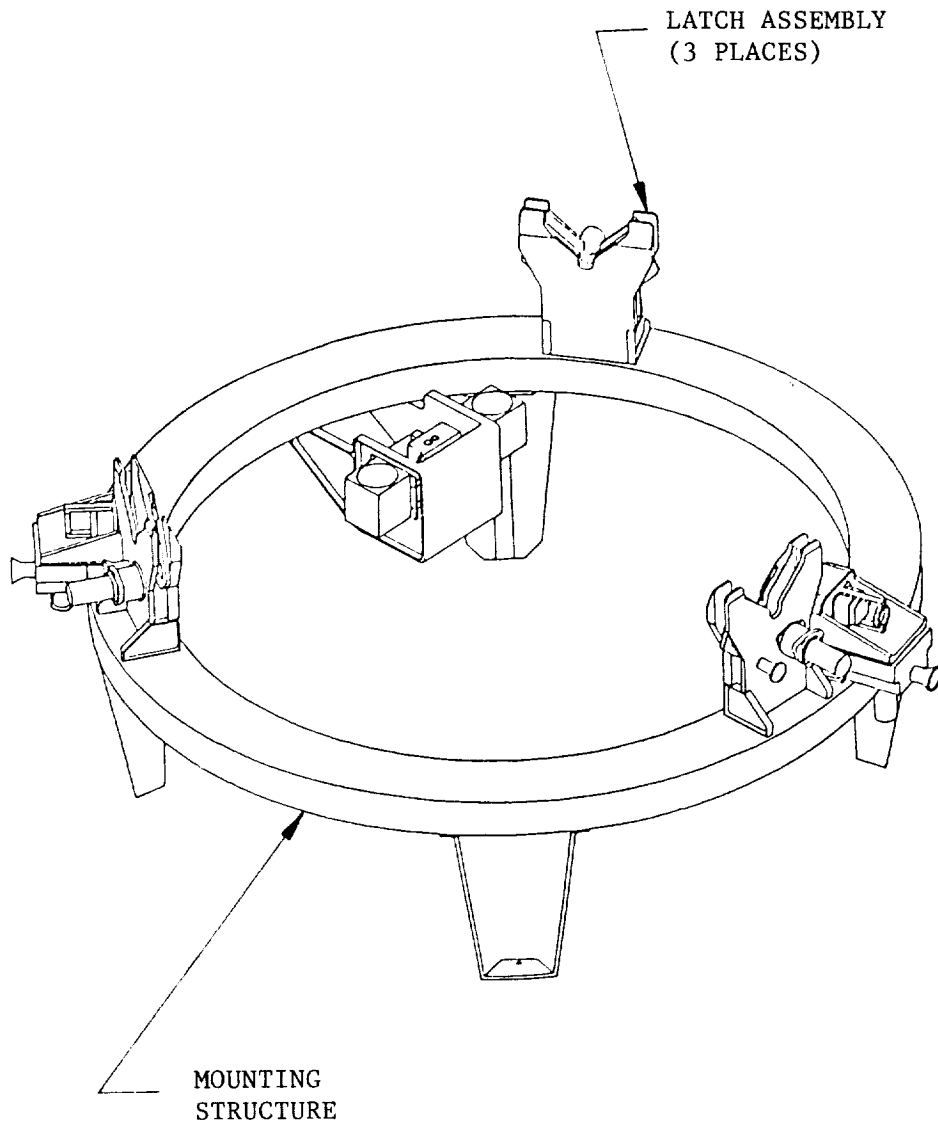

OMV TPDM

FIGURE 1

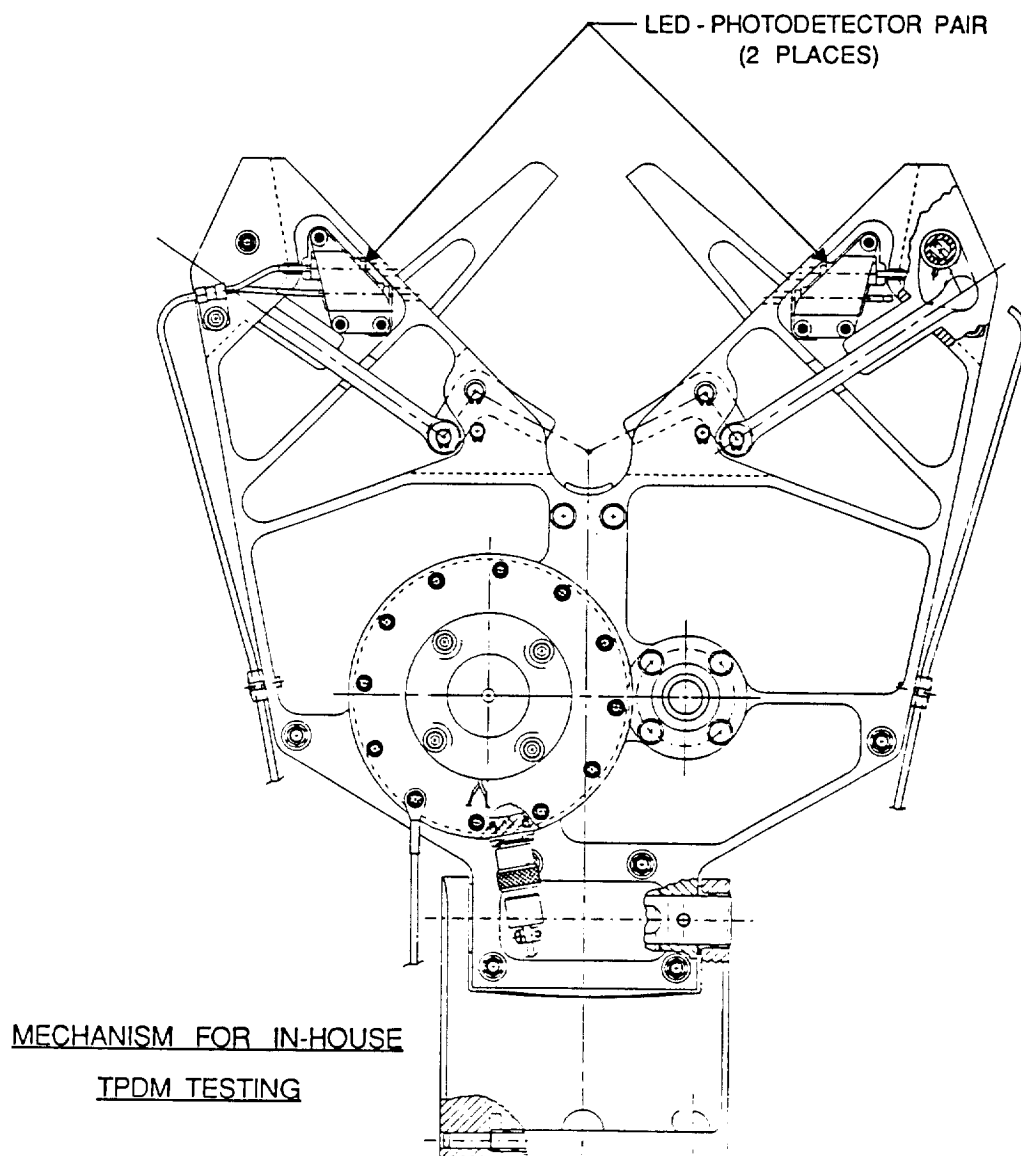

FIGURE 2

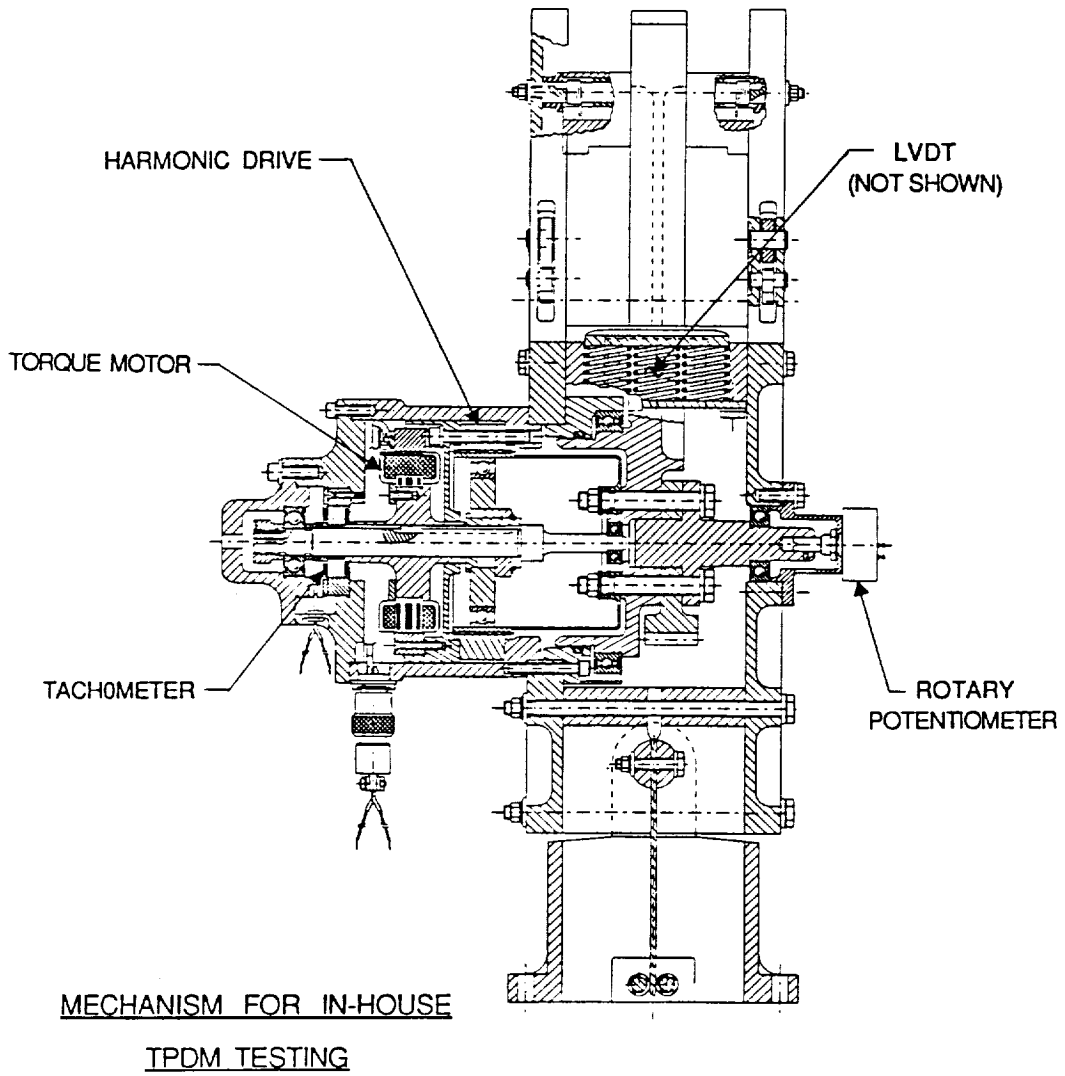

FIGURE 3