

N90-22101

AX-5 SPACE SUIT BEARING TORQUE INVESTIGATION

by Stuart Loewenthal*, Vic Vykukal**, Robert MacKendrick⁺
and Philip Culbertson Jr.⁺⁺

ABSTRACT

This report describes the symptoms and eventual resolution of a torque increase problem occurring with ball bearings in the joints of the AX-5 space suit. Starting torques that rose 5 to 10 times initial levels were observed in crew evaluation tests of the suit in a zero-g water tank. This bearing problem was identified as a blocking torque anomaly, observed previously in oscillatory gimbal bearings. A large matrix of lubricants, ball separator designs and materials were evaluated. None of these combinations showed sufficient tolerance to lubricant washout when repeatedly cycled in water. The problem was resolved by retrofitting a pressure compensated, water-exclusion seal to the outboard side of the bearing cavity. The symptoms and possible remedies to blocking are discussed.

INTRODUCTION

The AX-5 space suit (Fig. 1), developed by the NASA Ames Research Center, exemplifies the next generation of space suit considered for use aboard Space Station Freedom. Its "hard" (aluminum) construction and bearing joints allows for significantly higher internal air pressures [57 kPa (8.3 psig)] than current fabric suit designs [30 kPa (4.3 psig)] without increasing crew work load. The higher internal pressure eliminates the need for extensive crew prebreathing of 100% oxygen prior to an EVA as required by the current shuttle suit. Mobility is achieved through joint rotation, thus suit performance is directly dependent on bearing performance.

Neutral buoyancy crew evaluation tests of the AX-5 suit were conducted in the Weightless Environment Test Facility (WETF) at the NASA Johnson Space Center (JSC). Some subjects noticed increase in joint torque after about 2 hours of immersion. The most notable joints were the elbows. However, the problem was not immediately apparent when the subject took off the suit (depressurized) and the empty suit was then repressurized. The initial investigation focused on lubricant washout from the bearings. The pressure retention lip seals, were located between the bearing and the interior of the suit to exclude crew perspiration from reaching the bearing during space operation. However, this location allowed WETF water to fill the bearing cavity during crew underwater evaluation.

Approach

Since consistently low torque at the joints was essential for astronaut acceptance of the hard suit concept, resolution of the bearing problem was of very high priority. The joints had to properly function both in a space environment as well as in the WETF at NASA JSC. Because water could reach the bearings, it was thought that the easiest fix was to find a lubricant that didn't washout. The baseline, perfluoropolyether (PFPE) 814Z space-qualified oil was quickly found to be unsuitable for water operation. It later became clear, after many tests with more than a dozen oils, that those which were viscous enough to resist washout were also too viscous to provide low breakaway or running torques. Therefore, it became necessary to explore possible bearing design changes. The goal was to

*Bearing Consultant, San Jose, CA

** NASA Ames Research Center, Mountain View, CA

+ Air-Lock, Inc., Milford, CT

++ Sterling Federal Systems, Inc., Palo Alto, CA

find a solution that caused a minimum amount of rework to the bearing joints since all of the joints had already been manufactured. The approach adopted consisted of the following points:

- Identify the mechanism responsible for rapid buildup in torque observed during underwater testing.
- Identify bearing design modifications which could eliminate the problem while evaluating the impact on the following constraints:
 - torque level
 - sensitivity to lubricant washout
 - design impact
 - cost & schedule
- Verify effectiveness of improvements through bench tests in water and in the NASA Ames Neutral Buoyancy Test Facility (NBTF)



Fig. 1 AX-5 Space Suit

**ORIGINAL PAGE
BLACK AND WHITE PHOTOGRAPH**

BACKGROUND

There were 34 ball bearings incorporated into the primary joints on the AX-5 suit. The joints included shoulder, elbow, hip, knee and ankle. Each joint contained an interconnected pair of bearings which were oriented at an angle to provide the required joint rotation (see Fig. 1). These bearings ranged in

pitch diameter from about 145 mm (5.7 inch) for the lower shoulder joint to about 320 mm (12.6 inch) for the hip joint. The bearings were machined by Air-Lock, Inc. in a 4-point or "X" configuration as part of an integral joint complete with urethane lip seal as illustrated in Fig. 2. In the case of the shoulder joint, the primary load is 2240 N (504 lbs) of thrust due to the 57.2 kPa (8.3 psig) differential pressure acting across the joint. Desired operational lives were on the order of 17,000 and 107,000 cycles of oscillation for the shoulder and elbow, respectively.

Bearing Description

The bearings were machined from 17-4 PH stainless steel as part of a joint assembly complete with urethane lip seal. The bearing assembly was loosely fitted into the joint housing having o-ring seals and held by circumferential retaining cables on inner and outer races. The 17-4 PH stainless steel was selected for corrosion protection and machinability. The bearing was machined into a 4-point configuration with a nominal 45 degree contact angle. The high contact angle was selected to reduce contact stress from the pressure generated thrust load. Bearing maximum contact stresses were less than 1.4 GPa (200,000 psi) for the shoulder joint, which was comfortably below the allowable brinell stress limit for the stainless steel race at a Rockwell hardness of about 38. A disadvantage of the machining process was that the races were considerably rougher than commercially ground bearings.

Delrin idler balls were used as separators. They were slightly smaller than the 440-C main balls [4.8 mm diameter vs 4.9 mm (0.1875 in. diameter vs 0.193 in.)]. By keeping the diameters close in size, the resulting radial reaction force on the idler balls and thus drag could be kept low (see Fig. 3). Both main balls and idlers were inserted via a fill slot cut into the outer race.

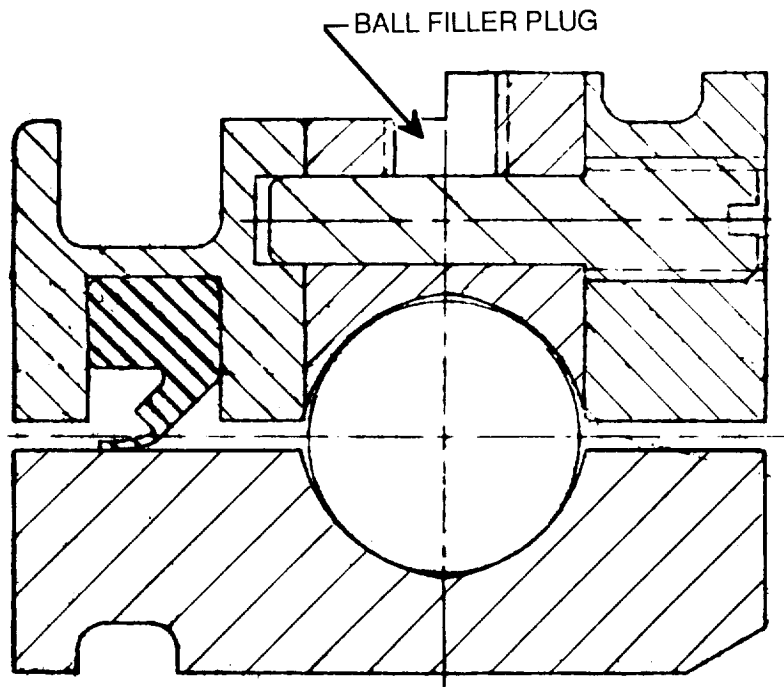

Fig. 2 Shoulder Joint Construction Showing Four-Point Bearing and Integral Seal

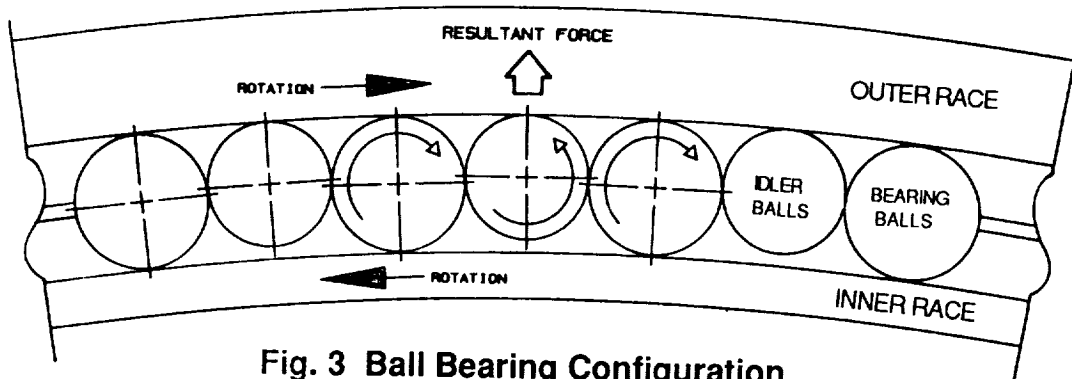

Fig. 3 Ball Bearing Configuration

Anomaly

Large torque increases were observed during oscillatory bearing life tests in bench tests with WETF water. An example of a test run on a shoulder joint bearing appears in Fig. 4. Normal breakaway torques were on the order of 0.23 to 0.34 N-m (2 to 3 in-lbs) and grew to more than 2.3 N-m (20 in-lbs) in the wet tests. 360 degree rotations tended to release or reduce the torque build up, as did ± 10 degree cycles. In some cases cutoff torque limits occurred in only 40 cycles.

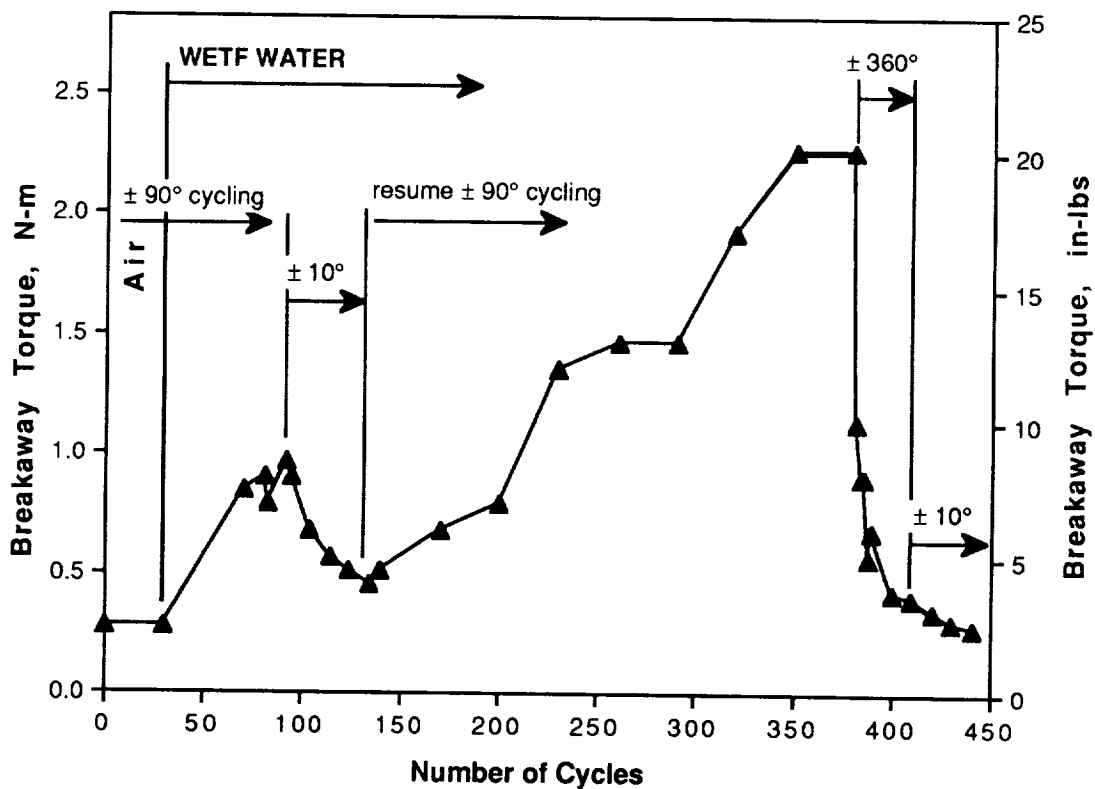

Fig. 4 Example of Bearing Torque Anomaly from Shoulder Joint Test

The observed large build up in breakaway torque with repeated oscillatory cycling appeared to be similar to the torque "blocking" observed by the authors in certain gimbals, see ref.[1], as well as by others, e.g. see refs. [2] and [3]. The term **blocking**, first coined in ref. [2], is used broadly to describe a progressive torque build-up with time. While no one fully understands this mechanism, blocking is thought to be a consequence of excess friction from the balls pinching the cage. This phenomena, sometimes descriptively referred to as "cage wind up", can occur when individual balls are orbiting at different speeds due to small variations in contact angle, ball size or race geometry. These ball excursions or *ball speed variation* (BSV) cause some balls to advance and others to retard from the average speed, squeezing the cage's ball pockets and thus increasing drag. Direct evidence of this came from tests where the idler balls were removed and the bearing balls were equally spaced apart. No torque build up was observed for the first 300 cycles.

The adverse effects of BSV on cage loading for continuously rotating bearings have been known for some time, as discussed in detail by Barrish [4]. An estimate of the contact angle variation of balls as they orbit helps set minimum ball pocket clearances. However, the use of enlarged ball pockets or slots will not necessarily correct the potential torque problems associated with bearings which oscillate back and forth, as observed here. Furthermore unidirectional rotation usually releases or resets bearing torque close to original levels (as illustrated in Fig. 4) while constant stroke oscillations tend to aggravate blocking.

BLOCKING REMEDIES

Based on the initial assessment of the AX-5 bearing problem, a series of possible solutions were considered, along with their difficulty to implement. These included:

Looser Conformity

Transverse ball creep due to "spin" was identified in refs. [1] and [2] as a significant factor contributing to blocking. Spin is the circumferential slip which results when a ball tries to roll along a grooved race at some contact angle. The sideways motion that results is akin to the "hook" of a bowling ball which is rolling with spin down the alley. This sideways motion causes some of the balls to ride up the race, increasing the contact angle, the BSV and hence the tendency to jam.

Increasing the races' transverse radius of curvature can significantly reduce this spin component and thus the tendency to block. In Ref.[1], increasing conformity (race radius/ball diameter) from 51.7 % to 54 % , completely cured the blocking at the expense of increased contact stress. The AX-5 bearings were already at 54% conformity and although contact stresses could be increased, this change necessitated regrinding the races. This had negative schedule and cost impacts. It also required sacrificing one or more of the limited number of bearings for test purposes. For these reasons, it was put on hold until less drastic fixes were evaluated.

Smoother Races

Improving surface finish and reducing the waviness of the bearing races were expected to help reduce friction and reduce the contact angle variation associated with BSV. The race drawings called out a race surface finish of $0.4 \mu\text{m}$ ($16 \mu \text{in.}$) rms and raceway diameter control to $\pm 0.025 \text{ mm}$ ($\pm 0.001 \text{ in.}$) in keeping with a machined surface. This is of lesser quality than standard commercial bearings having hardened and ground raceways. Since torque blocking problems were not encountered on previous joint designs containing commercial bearings, improved race surface quality could be important. However, this modification would also require that the joints be remanufactured. "Polishing" the races was later tried with no apparent success to alleviating blocking, possibly because surface polishing can't effectively correct imperfect race geometry.

Reduced Contact Angle

As mentioned earlier, ball/race spin creates side forces which cause the bearing balls to climb up the bearing races. Spin is increased with an increase in contact angle so the effect of reducing contact angle was investigated.

Contact Angle Measurement - Before proceeding, it was necessary to know what the contact angle was under load, i.e. while operating. In the case of a 4-point bearing, there is a complicated relationship between free or manufactured contact angle and diametral play, race conformity and removed shim thickness. It was believed that the bearings were manufactured to a nominal 45 degree contact angle, although it was difficult to verify mathematically. A preferred method of determining contact angle, both free and loaded, is by rotating the inner race many revolutions and counting the number of revolutions of the orbiting ball group. This method is commonly referred to as the "turns" method. It is based on the well known kinematic relationships of epicyclic motion, such as those associated with planetary gears. In the case of a bearing with a fixed outer race, the contact angle β is given by:

$$\cos \beta = \frac{E}{d} \left(1 - \frac{2 \varnothing_c}{\varnothing_s} \right)$$

where: E = bearing ball pitch diameter
 d = ball diameter
 \varnothing_c = number of cage or ball group revs
 \varnothing_s = number of shaft revs

Nominal contact angles under load for shoulder bearings S/N 101 and S/N 105 were measured to be 36.4 and 42.8 degrees, respectively, using the turns method. Each bearing inner race was rotated 100 revs and the ball group rotations were counted. The measurement was repeated 2 more times with close agreement.

Effect on Contact Load & Spin - Next the effect of smaller and larger contact angles on contact normal load and contact stress were calculated. The effect of reducing contact angle from 42 to 36 to 20 degrees, increased ball contact load from 46 to 52 to 82 N (10.3 to 11.8 to 18.4 lbs), respectively. This is due to the wedging effect with shallower angles under a pure thrust load. A spin analysis, similar to that conducted in Ref. [1], showed that the corresponding spin velocities for the above cases drop from 0.56 to 0.47 to 0.27 rads/sec. However, even though there was a 38% decrease in spin side force when the contact angle dropped from 45 to 20 degrees, the spin torque actually increased by 65% due to the increase in ball contact normal load. Thus the introduction of smaller contact angles would likely inhibit the blocking tendency at the expense of higher breakaway torques.

Reduced Friction Coefficient

Reducing the friction coefficient between the balls and races and between the balls and idler balls was the most obvious and easiest thing to try since no major bearing geometry change would be required. Unfortunately, finding the right combinations of idler ball material, cage design and lubricant which gave long term satisfactory performance both in and out of WETF water was anything but easy. The basic dilemma was that lubricants that were viscous enough not to be quickly washed out in water, gave relatively high breakaway torques. Those that provided low breakaway torques were too thin to last in water and quickly caused blocking.

Lubricants - The 814 Z oil, baselined for space use, was of very low viscosity (22 cS @ 100 °F) and had poor staying power in water. It was selected because its low viscosity would reduce the bearing running torque during joint rotation. However it was recognized that 814 Z oil because it is comprised of the lighter, hence more volatile, constituents has poorer outgassing characteristics than 815 Z type, the most common space mechanism oil. A total of about 20 different lubricants or greases diluted with freon were investigated. For example, a freon-diluted Mobil 28, mineral oil-based grease, that found prior success in the WETF tank showed improvement but also blocked in water. Exxon furnished several samples of water resistant lubricants with possible low breakaway torque capabilities. The two oils which appeared to have the most potential were Arox EP 46 and Teresstic 32. The Arox oil was specially formulated for rock-drilling machinery bathed in high pressure water. It contained a "tackiness" agent to inhibit wash off and an emulsifier agent to prevent the water from wetting the surface. Teresstic was designed to lubricate steam turbines and other precision machinery, such as those in paper mills. Unfortunately these oils had an inability to "wet" thus lubricate the urethane seal material, as evidenced by their "beading" on the seal surface and therefore received limited bearing testing.

Improved Ball Separator

The successful test with the idler balls removed gave hope that there was a way to keep the idler balls slippery or of finding a compliant material that wouldn't bind when pinched or a cage design that wouldn't allow the balls to jam.

Idler Ball Materials - A series of tests were conducted to identify the right idler ball material and lubricant combination. Fig. 5 synthesizes the breakaway torques of many of the test candidates. This data covered the first 500 cycles or until blocking torque stabilized, whichever ever came first. Black oxide-coated, stainless steel idler balls were tested with both 814Z and Mobil 28 grease, in and out of water. Breakaway torques in water generally started at about 0.3 N-m (2.5 in-lbs) and would climb to 0.8 to 1 N-m (7 to 9 in-lbs) inside of 300 cycles by hand rotation, occasionally drifting down to 0.6 N-m (5 in-lbs) at the end of 500 cycles. Krytox grease (a grease with a PFPE oil similar to 814 Z or 815 Z oils) gave similar results with the baseline Delrin idler balls. A full

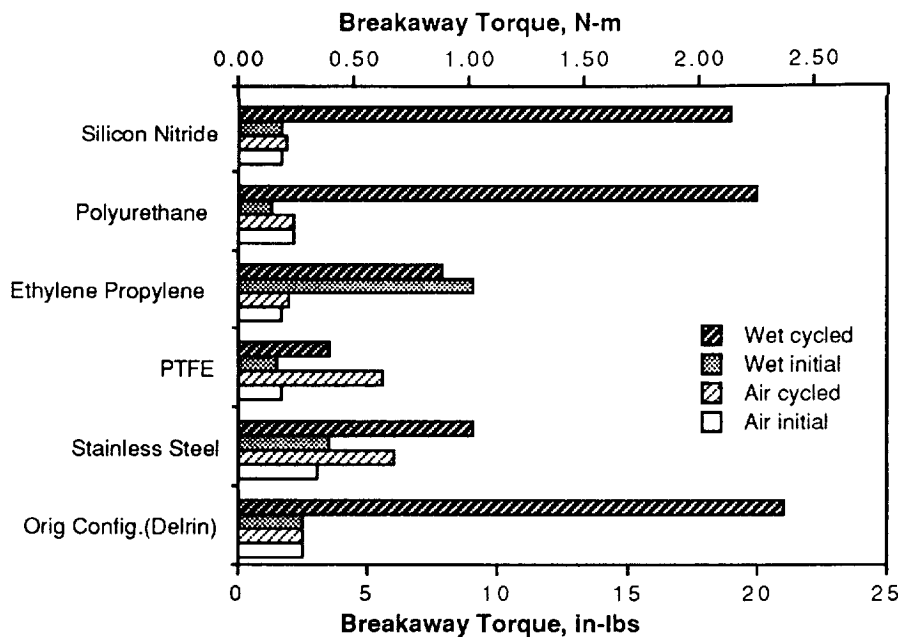

Fig. 5 Effect of Different Idler Ball Materials on Shoulder Joint Bearing Torque

complement of stainless steel bearing balls blocked almost immediately. Silicon nitride (Si_3N_4) idlers showed poor water performance, pointing out the importance of a compliant ball separator.

PTFE tube spacers, both large and small diameter, locked up in air in less than 200 cycles with 814 Z oil while PTFE idler balls gave relatively good results both in and out of water. Breakaway torques rose from 0.2 N-m (1.7 in-lbs) initially to 0.6 N-m (5.5 in-lbs) after 450 cycles out of water and 0.45 N-m (4.0 in-lbs) after 570 cycles in water. However, the PTFE balls showed some small dimples (1mm in diameter) under a microscope, indicating that the relatively soft PTFE was undergoing local brinelling.

A series of elastomeric idler balls of various shore hardnesses were investigated next. These included polyurethane/shore 60 to 90, ethylene polypropylene/shore 70 and Viton/shore 67 to 90. These materials gave good results up to 1300 cycles when lubricated but blocked badly when the lubricant washed out. This was an expected result considering the high coefficient of friction of these elastomers when unlubricated. Thus elastomeric idler balls were considered to be too risky with the ever present danger of lubricant migration or degradation. It became increasingly clear that finding a lubricant/material combination that would consistently work in water was getting more and more unlikely.

One Piece Cage - Kaydon manufactures a one piece, alternating slotted and circular pocket, snap over cage which it recommends for oscillatory bearings to inhibit torque anomalies. The theory is the slots will allow some free ball migration between back and forth oscillations. There was an interest in evaluating the effectiveness of such a retainer design in relation to other tests conducted, although an existing shoulder joint had to be reworked. The shoulder of the bearing was machined away to accept either a bronze, one piece slotted cage or an enlarged, circular ball pocket cage. Test results (see Fig. 6) showed that the slotted cage exhibited little torque buildup out of water but breakaway

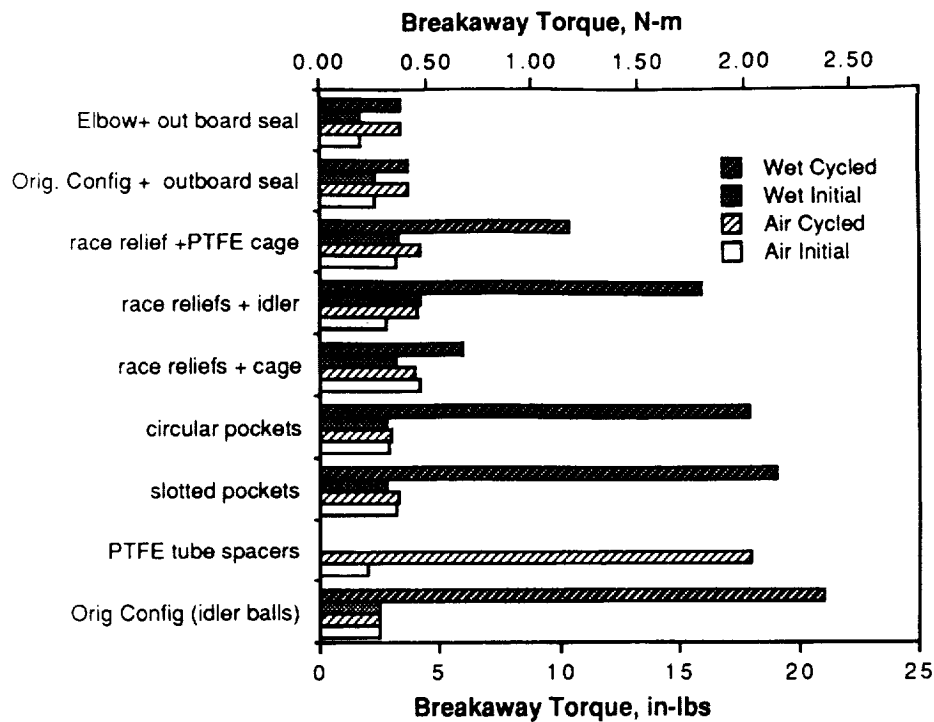

Fig. 6 Effect of Different Geometries, Race Reliefs and Outboard Seals on Shoulder Joint Bearing Torque

torques ranged from about 1.1 to 2.2 N-m (10 to 19 in-lbs) in water. The enlarged circular pocket cage exhibited similar behavior with torques to 2 N-m (18 in-lbs). Spray coating the cages with PTFE kept torques under 0.7 N-m (6 in-lbs) for the first 500 cycles in water. However, there was a persisting risk of PTFE wear through with this approach.

Race Reliefs - The balls are under an essentially constant load in a thrust loaded bearing, so if unequal ball spacing were to occur due to BSV, there is no opportunity to relieve the resulting wind-in torques. However, if a small region of the inner or outer race was recessed, then the ball passing over this relief would be momentarily unloaded and thereby given an opportunity to "release" its pinching load. (For this reason, radially loaded bearings are less apt to experience blocking since some balls can enter the unload zone opposite the radial load contact). Since the AX-5 joints can experience small angular motions, it was necessary to grind in multiple reliefs to be assured that each ball had an opportunity to pass over a relief during limited angular ball travel. Fig. 7 shows the geometry of the race reliefs cut a minimum of 0.002 inch along the nominal 45 degree contact at 18 locations. This depth was about 10 times the expected Hertzian deflection to guarantee ball unloading. Wet tests with a PTFE coated, one piece, circular pocketed, bronze cage exhibited some improvement but less so for a glass- reinforced PTFE cage (see Fig. 6). However, race relief tests with polyurethane idler balls show outstanding performance out of water, although torque once again rose dramatically in water.

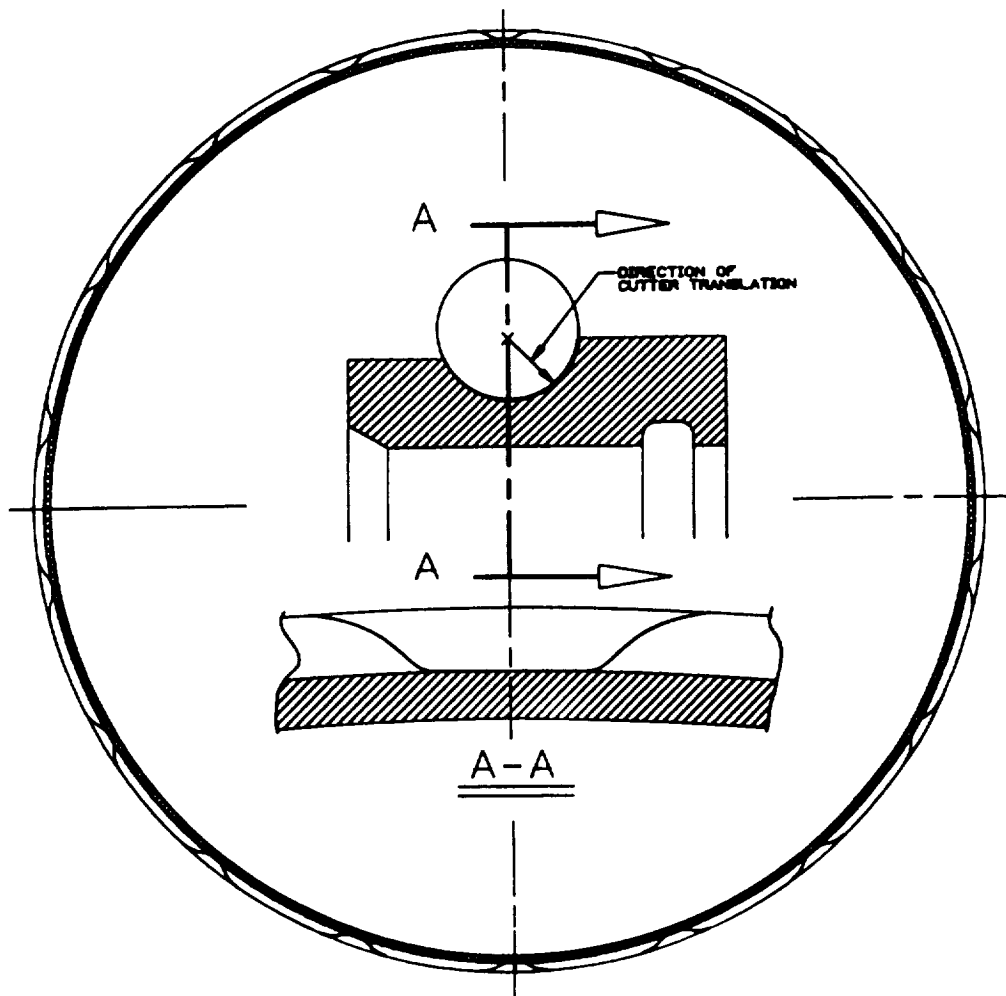

Fig. 7 Details of Race Reliefs

OUTBOARD SEAL REDESIGN

Based on the inconsistent results with all prior attempted solutions, the bearing joint assembly was modified to accept an outboard seal to exclude water from the bearing cavity. This meant that all of the suit joints would have to be remanufactured and a method found to alleviate the high hydraulic differential pressure acting across the seal in the WETF tests with resulting high seal drag forces. A solution was found that balanced the pressures across this seal by regulating the pressure within the bearing cavity at some intermediate level. This was accomplished by allowing a small, but controlled air flow leak between the pressurized interior and the bearing cavity through a ruby metering orifice designed for such leakage control. In this way, seal differential pressure could be limited and the bearing cavity would remain dry. A cross-section through the under water test version of this double-sealed joint appears in Fig. 8. The pressurized interior of the suit is to the left in this figure. Note that some air would leak past the circular retaining cable and through the metering orifice to maintain bearing cavity pressure slightly below external water pressure. For space operation, the outboard seal is reversed against the external vacuum. The metering plug was relocated to the ball filler plug to reduce the differential pressure acting across the outboard seal.

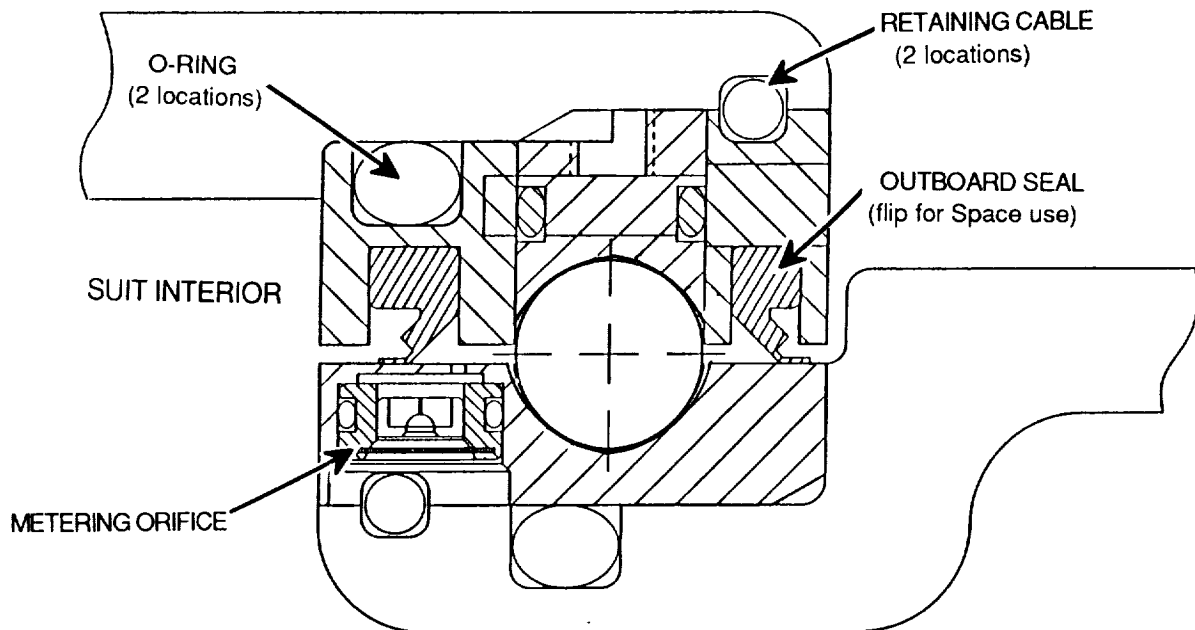

Fig. 8 AX-5 Bearing Joint Configuration for Underwater Tests

Although remanufacturing all the joint sub assemblies to accept this seal modification was not inexpensive, this approach positively eliminates lubricant wash out as a failure mode. Breakaway torques inside and outside of water remained nearly constant. An elbow joint torque trace covering 1000 oscillatory cycles appears in Fig. 9. Comparison of torque levels from shoulder and elbow joints with other designs is given in Fig. 6.

A modified shoulder bearing received 15,200 cycles or 43.5 hours of operation in water without torque buildup. Except for the outboard seal and metering plug, the bearing is the original configuration, lubricated with 814 Z oil and containing Delrin idler balls. Starting torque began at 0.3 N-m (2.4 in-lbs) rose to 0.5 N-m (4.2 in-lbs) at 9400 cycles and remained essentially constant until cutoff at 15,200 cycles. Running torques at 90 degs/sec were 0.85 N-m (7.5 in-lbs) initially, rose to 1.1 N-m (9.9 in-lbs) at 6100 cycles and then fell to 0.9 N-m (8.1 in-lbs) at 15,200 cycles.

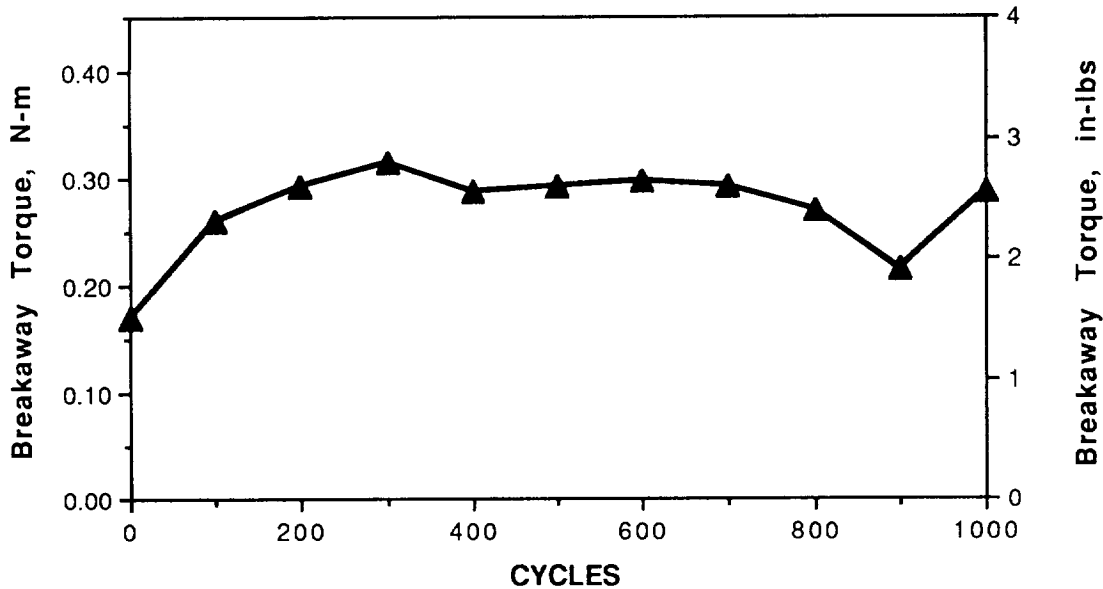

Fig. 9 Breakaway Torque Profile for Elbow Joint Bearings with Outboard Seals

The shoulder joint was depressurized at the end of each approximate 8 hour test day for a total of 6 times during the test. Depressurizing or unloading the bearing will generally reset the bearing torque if blocking is present. Although the totals achieved are not a single continuous run, the operational time per period greatly exceeds any of that anticipated for the suit in testing and or in service. Thus there is high confidence that torque blocking problems will not be observed. The effectiveness of this solution was later confirmed during successful crew evaluation tests of the AX-5 suit in the WETF at NASA JSC.

CONCLUSIONS

This investigation identified blocking to be responsible for the torque increases observed in the bearing joints of the AX-5 space suit. This torque anomaly was clearly aggravated by lubricant washout from the bearings during underwater tests which simulated crew evaluation in the NASA JSC WETF. The most telltale signs of blocking were the relatively rapid build-up of torque, the torque resetting upon unidirectional rotation and the absence of the problem when the bearing balls were freely spaced without separators. A large matrix of lubricants, idler ball material and ball separator designs were evaluated as possible solutions. None of these approaches worked consistently well in the water tests. The ultimate remedy was to provide a water-exclusion outboard, lip seal to the bearing joints, although this necessitated that all of the numerous joint assemblies had to be remachined. Some of the more general findings of this study are as follows:

- (1) High ball/cage friction can cause blocking in oscillatory bearings no matter how well the cage may be designed.
- (2) In difficult lubrication situations where blocking may occur, unidirectional rotation past the point of jamming will likely reset torque, at least temporarily.
- (3) Constant stroke oscillations are more likely to cause blocking than a more random sequence of motion.
- (4) Slightly undersized idler balls make effective ball separators, provided good lubrication can be maintained.

REFERENCES

- [1] Loewenthal, Stuart H.: "Two Gimbal Bearing Case Studies: Some Lessons Learned" ; Proc. of 22nd Aerospace Mechanisms Symposium, NASA CP-2506, May 1988, pp. 253-269.
- [2] Todd, Mike J.: "Investigation of Torque Anomaly in Oscillating PDM Bearings" European Space Agency (ESTL) Report No. 49, May 1981.
- [3] Phinney, D.D. ; Pollard, C.L. ; and Hinricks, J.T. : "Experience with Duplex Bearings in Narrow Angle Oscillating Applications"; Proc. of 22nd Aerospace Mechanisms Symposium, NASA CP-2506, May 1988, pp. 211-226.
- [4] Barrish, Tom: "Ball Speed Variations in Ball Bearings", ASLE J. Lubrication Engineering, Mar. 1969, pp. 110-116.