

N90-22305

**NASA GROUND TERMINAL COMMUNICATION EQUIPMENT
AUTOMATED FAULT ISOLATION EXPERT SYSTEMS**

Y. K. Tang and C. R. Wetzel

Ford Aerospace Corporation
7375 Executive Place
Seabrook, MD 20706**ABSTRACT**

This paper describes the prototype expert systems that diagnose the Distribution and Switching System I and II (DSS1 and DSS2), Statistical Multiplexers (SM), and Multiplexer and Demultiplexer systems (MDM) at the NASA Ground Terminal (NGT). A system level fault isolation expert system monitors the activities of a selected data stream, verifies that the fault exists in the NGT and identifies the faulty equipment. Equipment level fault isolation expert systems will be invoked to isolate the fault to a Line Replaceable Unit (LRU) level.

Input and sometimes output data stream activities for the equipment are available. The system level fault isolation expert system will compare the equipment input and output status for a data stream and perform loopback tests (if necessary) to isolate the faulty equipment. The equipment level fault isolation system utilizes the process of elimination and/or the maintenance personnel's fault isolation experience stored in its knowledge base. The DSS1, DSS2 and SM fault isolation systems, using the knowledge of the current equipment configuration and the equipment circuitry, will issue a set of test connections according to the predefined rules. The faulty component or board can be identified by the expert system by analyzing the test results. The MDM fault isolation system correlates the failure symptoms with the faulty component based on maintenance personnel experience. The faulty component can be determined by knowing the failure symptoms.

The NGT fault isolation prototype is implemented in Prolog, C and VP-Expert, on an IBM AT compatible workstation. The DSS1, DSS2, SM, and MDM equipment simulators are

implemented in PASCAL. The equipment simulator receives connection commands and responds with status for the expert system according to the assigned faulty component in the equipment. The DSS1 fault isolation expert system was converted to C language from VP-Expert and integrated into the NGT automation software for offline switch diagnoses.

Potentially, the NGT fault isolation algorithms can be used for the DSS1, SM, and MDM located at Goddard Space Flight Center (GSFC). The prototype could be a training tool for the NGT and NASA Communications (Nascom) Network maintenance personnel.

1.0 INTRODUCTION

This section will describe the background, problem, objective, and scope of this paper.

1.1 Background

The NGT is located with the ground terminal portion of the Tracking and Data Relay Satellite System (TDRSS) at White Sands, New Mexico. The primary role of the NGT is to serve as the interface for communication between the TDRSS and NASA facilities at Goddard Space Flight Center (GSFC) and Johnson Space Center (JSC). The primary functions of the NGT are data transport, data quality monitoring, and line outage recording and data rate buffering.

In order to meet the future (early 1990's) workload of multiple Tracking and Data Relay Satellite (TDRS) support and user support requirements, an NGT Automation (NGTA) project was completed at the end of 1989 (GSFC, STDN No. 528, 1986). The NGTA provides the capabilities to automatically configure the major NGT subsystems and to monitor their

health and status using high-speed scheduling messages from the Network Control Center (NCC). The major communication equipment includes the Distribution and Switching System I and II (DSS1 and DSS2), Statistical Multiplexers (SM) and Multiplexer and Demultiplexer systems (MDM) as depicted in Figure 1. They are controlled and monitored by the DSS1 Interface Processor (IP), SM and DSS2 Interface Processor (SMD IP), MDM Automatic Control System (MACS) and NGT Control and Status System (NCSS) as depicted in Figure 2.

The NGT communication equipment troubleshooting is done manually, although much of the equipment health status is monitored automatically. The manual troubleshooting requires a skilled technician and is time consuming. An automated fault isolation system will significantly reduce the equipment down time and the required technician skill level. The rule based expert system technique has been used to assist fault isolation tasks for various GSC supported projects (Erikson and Hooker, 1989; Luczak, et al., 1989; Lowe, et al., 1987).

1.2 Problem

The communication equipment at NGT was built in the late 1970's or early 1980's. This equipment does not allow the internal signal status to be monitored remotely. For example, the DSS1 sends to the DSS1 IP the data and clock present status at the input and output ports and also sends the result of the comparison of the input and output port signals. Only this status information received by the IP is available for the automated fault isolation process. There is no status available between the input and output ports. The internal signal monitoring capabilities are also limited for the DSS2, MDM, and SM. With limited status information, it is not possible to directly identify a faulty LRU (usually a circuit board) within the equipment.

NASA is building the Second TDRS Ground Terminal which will replace the NGT functions during the middle 1990's. It is not cost effective to enhance the NGT communication hardware to provide more internal monitoring capabilities for the fault isolation purpose. Therefore, the proposed automated fault

isolation system shall use only the existing computer hardware capability and shall not impact the performance of the other functions.

With these limitations, it is a challenge to develop a low cost automated fault isolation system for the NGT in a timely manner. The specific objectives of the NGT automated fault isolation prototype follow.

1.3 Objectives

The major objective of this study is to develop an automated fault isolation system prototype using a rule based expert system to prove the feasibility of building a low cost fault isolation system that meets all the restrictions as previously described. The secondary goal is to eventually convert the prototype to an operational system. The prototype can also be used for the following:

- to explain the fault isolation approach and methodology as a training tool
- to verify the methodology during its development
- to identify the operator interface requirements.

1.4 Scope

The fault isolation prototype was developed for the DSS1, DSS2, MDM, and SM. The interface processors for the equipment were not included.

2.0 APPROACH

The NGT automated fault isolation concept takes the top down approach. The system level fault isolation expert system will first verify that the fault indeed occurred in the NGT and will identify the faulty equipment. It will then invoke an equipment level fault isolation expert system to identify the faulty component at the LRU level. There is an equipment level fault isolation expert system for each piece of equipment.

The system level fault isolation expert system will compare the equipment input and output status for a data stream and perform loopback

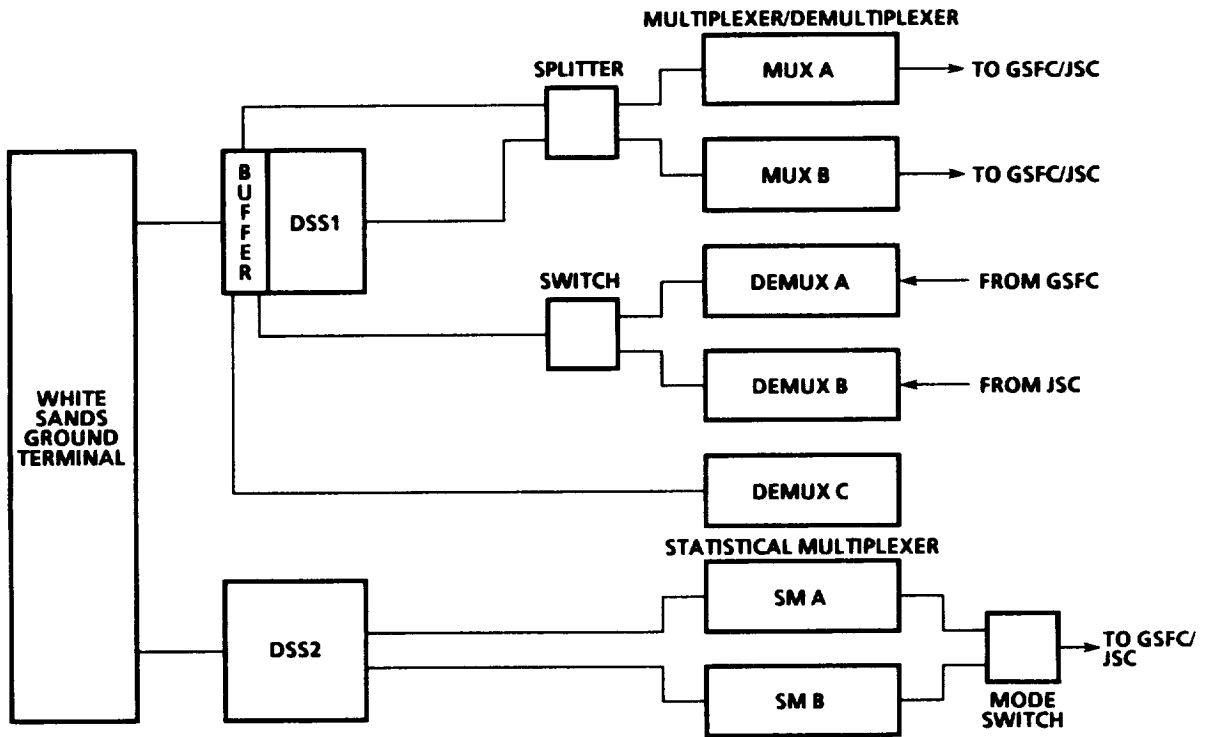

Figure 1. The NGT Communication Equipment

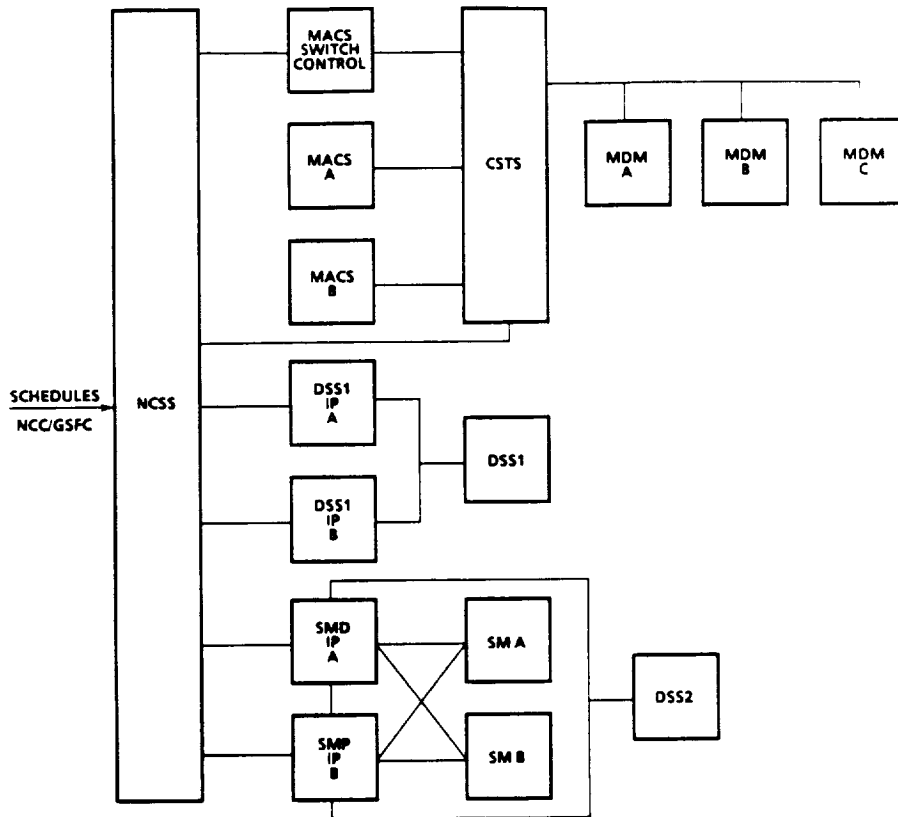

Figure 2. The Control and Monitoring of the NGT Communication Equipment

tests (if necessary) to isolate the faulty equipment. The equipment level fault isolation system utilizes the process of elimination and/or the maintenance personnel fault isolation experience stored in its knowledge base. The DSS1, DSS2 and SM fault isolation systems, using the knowledge of the current equipment configuration and the equipment circuitry, will issue a set of test connections and analyze test results according to the predefined rules.

For instance, a test data path can be chosen so that only one component on the faulty data stream is not shared by both paths (it is substituted by another component which is known to be good). If the data path is good, it can be concluded that the component not used for the test is bad. Otherwise, another component in the faulty data stream is bad and more tests are required. Using this substitution and elimination method for all components in the faulty data stream, the faulty component or board can be identified. The MDM fault isolation system correlates the failure symptoms with the faulty component based on the maintenance personnel experience. The faulty component can be determined by knowing the failure symptoms.

The system level fault isolation software can reside in the NCSS computer since it has the activity status of all equipment in the data stream. The equipment level fault isolation system can be distributed to the corresponding IP which has the capability to monitor the data stream activity status (i.e. clock or data present), and to issue test commands for additional information. The rules to compare the equipment status and to determine test cases are simple. The additional code allocated to each IP will not impact the NGTA performance. This approach provides an efficient method to achieve the NGT automated fault isolation goals under the restrictions previously described. The detailed algorithms to identify the faulty equipment and component have been prototyped and the results are presented in the following paragraphs.

3.0 FAULT ISOLATION ALGORITHMS

Both the system level and equipment level fault isolation system prototypes were developed. For each equipment level fault isolation system,

an equipment simulator was built to receive test commands and to respond with status messages according to the assigned failure.

3.1 System Level Fault Isolation

The NGTA data base in the NCSS stores the data stream service configuration and scheduling information which is available to the expert system. From this, the expert system can find all the equipment used to support the data stream. The expert system will use the information for fault isolation from any equipment in the data stream that may cause an alarm or complaint. This system level NGT fault isolation can be initiated by the operator.

The system level fault isolation expert system will isolate the faulty equipment in the NGT if the data stream status is good at the equipment input port and is bad at the output port. The system will conclude that there is no fault in the NGT if all the status along a data stream in the NGT are bad and if the service is during the spacecraft acquisition, reacquisition, ground equipment reconfiguration, service-to-service handovers or first several minutes of service. During these periods, the data stream is not stable (Miksell, et al., 1987).

The system will configure the NGT ground equipment to perform loopback tests if the input data stream status is good and the output status is not available. Data stream signals at the MDM Output Controller (OC) output port, Nascom's Domestic Satellite (DOMSAT) downlink, or SM transmitter output are available for loopback tests through switching. If the loopback test shows the data stream is good, the fault is not in the NGT.

The system level fault isolation system will invoke the equipment level fault isolation system to identify the fault to the LRU level. The following paragraphs describe the equipment level fault isolation principles.

3.2 Distribution and Switching System I

The DSS1 provides buffering and switching for 192 digital low-data rate signals that pass through the NGT. The design of the DSS1 is based on a Clos-type nonblocking switch array that consists of stage A, B, and C cards. One test

card and 8 input cards are also used to monitor switch status and to generate test data.

The Input, A, B, and C cards consist of decoders and selectors (4 to 1 selection). The health of a card is determined by testing the health of the decoder and selector used for a connection. The status of a selector can be determined by making a new connection that uses a different selector but otherwise the same components in the A, B, and C cards as the faulty connection. This can be done since a decoder controls a group of selectors. If the new connection is good, the selector on the faulty connection path is bad. Otherwise, another component on the path is bad and the decoder needs to be tested next. The new connection shall consist of all new components except the decoder. If the new connection is bad, the decoder is bad. Otherwise, the decoder and selector of another card on the connection path shall be tested. Through the process of substitution and elimination the faulty component and the faulty card can be determined.

The expert system, with the knowledge of switch circuitry and the current connections, will find the proper free ports to support tests, issue commands to conduct the tests, and interpret the test results.

3.3 Distribution and Switching System II

The DSS2 consists of 48 data/clock pair inputs and 40 data/clock outputs. The major line replaceable modules of the DSS2 are as follows: input module, switch module, multiplexer module, output module, peripheral electronics assembly, and computer assembly.

The clock and data status are monitored at the input module and the output module. An example of an algorithm to isolate the faulty module if the data status is good at the input but bad at the output follows.

A connection test is made by connecting the same input to a proper output such that the faulty connection and test connection share the same switch module and the same switch Large Scale Integration (LSI) circuitry in the switch module. If the new connection is good, the faulty module is either the multiplexer module

or the output module. Otherwise, the faulty module is either the input module or the switch module.

To distinguish whether the fault is the input module or the switch module, another test is required. The new test will use the same input module and switch module as the faulty connection, but will select an output that uses a different switch LSI in the same switch module. If the new connection is good, the switch LSI is faulty, otherwise the fault is either the input module or the fan-out board in the switch module. More tests are needed to complete the fault isolation process.

The DSS2 fault isolation expert system has the knowledge base and rules to perform the process of elimination as previously described and will isolate the faulty module or modules.

3.4 Multiplexer and Demultiplexer

This section describes the fault isolation algorithms for the multiplexer and demultiplexer portions of the MDM separately.

3.4.1 Multiplexer

The Multiplexer systems at the NGT consist of 100 Input Terminal Units (ITU) and Triple redundant Output Controllers (OC). The Multiplexer system is fully redundant. Both prime and alternative systems process and transmit the composite data streams simultaneously. The fault isolation processes includes loopback tests and direct interpretation of the failure symptoms.

Only the input clock status at the ITU for a data stream in the Multiplexer system is monitored. Loopback tests are required to determine that the fault is indeed in the Multiplexer as described 3.1. If the fault is determined to be in the Multiplexer, and GSFC or JSC experience problems on all the data streams from the NGT, the fault is in the OC. If only one data stream has problems, the fault is in the corresponding ITU. There are three boards in an ITU and 7 boards in an OC. Further fault isolation to the board level requires the knowledge that associates the failure symptoms and/or alarm messages to the most likely faulty board.

The expert system, with the knowledge of the multiplexer configurations from the service schedules and the failure symptom correlations from maintenance personnel experiences, will configure the loopback tests and interact with the operator to isolate the faulty board.

3.4.2 Demultiplexer

A demultiplexer consists of one Input Controller (IC) and 30 Output Terminal Units (OTU). There are two Demultiplexer systems at the NGT to process the signals from GSFC and JSC separately. The third one is used as a spare and/or to support a recorder playback function.

The Demultiplexer fault isolation is based on the error messages the demultiplexer generates and the failure symptoms the operator observes. Instead of loopback tests, the spare demultiplexer is used to support fault isolation. The composite data stream from GSFC or JSC will be routed to the spare unit and demultiplexed, and the output data stream status will be monitored. If the data stream is good then the fault is in the NGT. There are three logic cards in an OTU and four logic cards in an IC. If only one data stream has problems, the fault is in the associated OTU. If all the data streams have problems, the fault is in the IC. Based on the failure symptoms the most likely faulty logic card can be isolated.

3.5 Statistical Multiplexer

The SM at the NGT consists of a transmit section and a receive section. Four input ports are available for the transmit section and four output ports are available for the receive section. A spare SM at the NGT is available for backup and fault isolation support.

There is a receive module and a transmit multiplex module within the transmit section. There are demultiplex modules, a pattern detector module, frequency synthesizers, and error drivers within the receive section. The transmit/receive module and high speed data driver boards are shared by both sections. During normal operations, the composite data stream output from the transmit section is looped back to the receive section of the same unit, and the composite data stream from the

SAT is looped back to the receive section of the spare unit for data status monitoring.

When the receive sections of both units indicate data or clock loss, the fault is in the transmit section. The service will be restored by switching the input data streams to the spare unit. The faulty module will be determined after the service is over and during equipment free time.

For instance, a transmit section fault can be determined by feeding the test data to all four input ports and looping the composite data to the receive section of the demultiplexer. If all ports at the receive section lose clock and data, the fault is in the transmit/receive module. If only one port at the receive section loses clock and data, the fault is in the corresponding transmit multiplex module. By examining the failure impacts the faulty module can be identified.

The expert system will interact with the maintenance personnel to setup the test data generator and to configure the loop back tests. The expert system will monitor the data stream status and determine the faulty module.

4.0 PROGRESS AND PROTOTYPE USAGE

The system level fault isolation expert system was implemented in dBASE III to take advantage of a relational file structure for storing the service schedules and configuration information, and for the ease in data input. The DSS1 fault isolation expert system was implemented in VP-Expert, a rule-based expert system development tool (Sawyer, et al., 1987). The DSS2, MDM, and SM fault isolation expert systems were written in Turbo Prolog. The simulators for the equipment were written in Turbo Pascal. All software was implemented on an IBM AT compatible workstation. The system level and the DSS1 equipment level fault isolation programs were converted to C language for possible integration with the operational NGTA software.

The user can test the prototype by assigning one communication equipment fault at the board or module level, by configuring a service identifying the equipment involved and ports used, and by starting data transmission. The prototype will issue the appropriate error

messages to indicate a system failure, then the user can initiate the fault isolation procedure. The system level fault isolation system will display the service configuration graphically along with all the available color coded clock and data status. The faulty equipment will be highlighted in red.

The equipment level fault isolation system will be invoked by the system level fault isolation system. The system will display a flow diagram to show all the modules in the equipment needed to support the faulty service along with the available status. The prototype will also show the test data path and status on the same diagram but in a different color. The components shared by both paths can be seen clearly. The component determined to be healthy after a test will turn green. The user is able to observe the process of elimination step by step until the faulty board or module is isolated. The test connections and results are also explained in the message window. The fault isolation result can be compared to the fault initially assigned to verify the success of the fault isolation system.

A series of tests were performed to debug the software and to verify the fault isolation algorithms. The fault isolation prototype successfully demonstrates the automated fault isolation capabilities. The DSS1 fault isolation algorithm was actually tested at the NGT. Chips in the A card, Input card and Test card were purposely damaged to create faults. A set of test connections were issued manually according to the fault isolation algorithm. By analyzing the connection test results, the faulty boards were correctly identified.

5.0 CONCLUSIONS AND RECOMMENDATIONS

The NGT fault isolation prototype does demonstrate the feasibility to apply expert system techniques to perform the automated fault isolation tasks with minimum operator intervention. The conclusions of the prototype implementation are as follows:

- The prototype proves that it is feasible to develop automated fault isolation algorithms for the NGT communication equipment.
- The fault isolation algorithms are simple and effective. There is no

hardware enhancement required to implement the algorithms.

- The fault isolation system software can be distributed and integrated into the NGTA subsystems to perform automatic test configuration, status monitoring and interpretation, and fault isolation with minimal impacts to the system response time.
- The prototype can be used as a training tool to explain the fault isolation algorithms.

The prototype demonstrates the feasibility and cost-effectiveness to add the automated fault isolation capabilities to the NGT. It is recommended that the fault isolation capabilities be implemented at the NGT and other NASA facilities with similar equipment such as Nascom and Second TDRS Ground Terminal.

REFERENCES

- Erikson, C., and Hooker, P., "Tracking & Data Relay Satellite Fault Isolation & Correction Using PACES: Power & Attitude Control Expert System," 1989 Goddard Conference on Space applications of Artificial Intelligence, May 1989.
- Lowe, D., et. al., "FIESTA: An Operational Decision Aid for Space Network Fault Isolation," 1987 Goddard Conference on Space applications of Artificial Intelligence, May 1987.
- Luczak, E., et. al., "REDEX: The Ranging Equipment Diagnostic Expert System", 1989 Goddard Conference on Space application of Artificial Intelligence, May 1989.
- Miksell, S., et. al., "Network Fault Diagnosis: Knowledge Representation Using Parallel Reasoning", 1987 Third Annual Expert Systems in Government Conference Proceedings, October 1987.
- "NASA Ground Terminal (NGT) Automation Project Plan," STDN No. 528, September, 1986, Goddard Space Flight Center.
- Sawyer, B., et. al., "VP EXPERT", PAPERBACK SOFTWARE INTERNATIONAL, 1987.

